

Gate Pulse Modulator.

- The KIA3820F/FK is specifically designed for application of TFT LCD glass panel.
- Flicker compensation circuit.
- Reduction of coupling effect between gate line and pixel.
- Power sequence circuit for gate driver IC.
- Operation from 15V to 38V positive supply input.
- Output delay time adjustable.

MAXIMUM RATING (Ta=25 °C)

CHARACTERISTIC	SYMBOL	RATING	UNIT
Positive Supply Voltage	V_{GH}	40	V
FLK Voltage	V_{FLK}	5	V
DPM Voltage	V_{DPM}	5	V
Output Current	I_O	30	mA
Power Dissipation	FK (US8)	200	mW
	F (FLP-8)	240	
Operating Temperature	T_{opr}	-30 ~ 85	°C
Junction Temperature	T_j	150	°C
Storage Temperature	T_{stg}	-40 ~ 150	°C

LINE - UP

ITEM	FUNCTION	PACKAGE
KIA3820F	Gate Pulse Modulator	FLP-8
KIA3820FK		US8

MARKING (US8 Package)

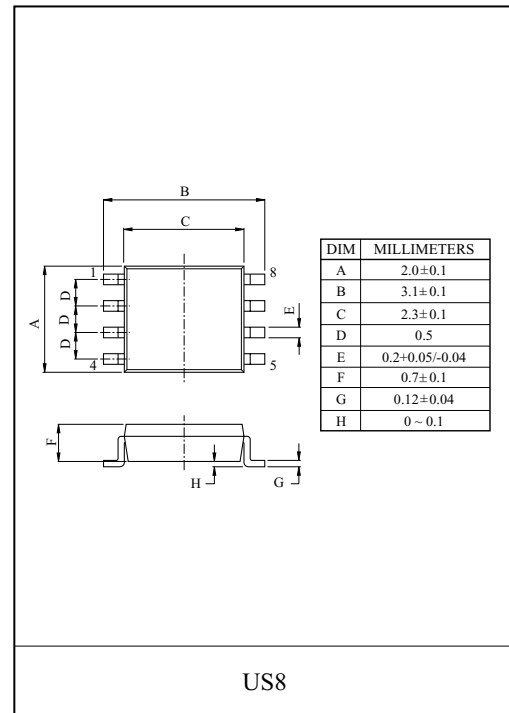
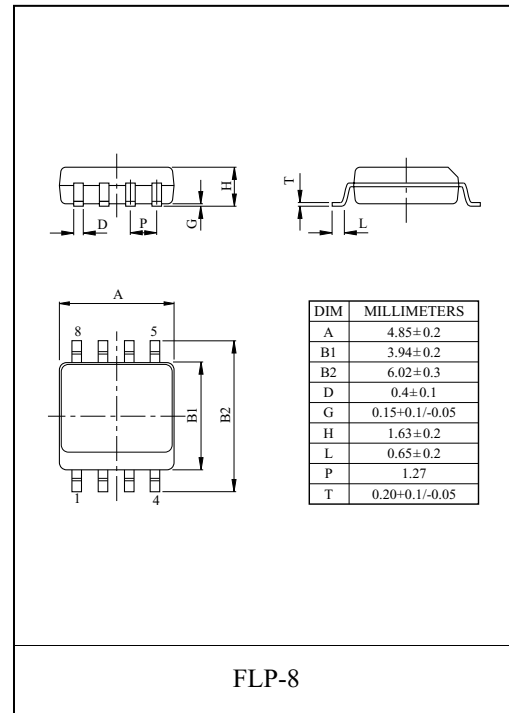
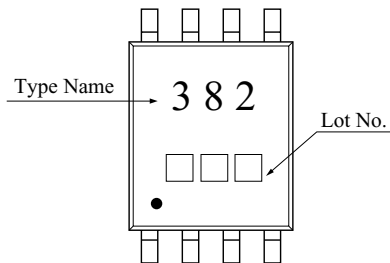

KIA3820F/FK

ELECTRICAL CHARACTERISTICS ($V_{GH}=20V$, $V_{DD}=10V$, $V_{DPM}=2.2V$, $V_{FLK}=2.2V$, $V_{GH}-V_{DD} \geq 8.5V$
 $T_a=25^\circ C$, Unless otherwise noted.)

CHARACTERISTIC	SYMBOL	TEST CONDITION	MIN.	TYP.	MAX.	UNIT
Power Supply Input	V_{GH}	$V_{GH}-V_{DD} \geq 8.5V$	15	-	38	V
Reference Input	V_{DD}	$V_{GH}-V_{DD} \geq 8.5V$	0	-	25	V
FLK High Voltage	$V_{FLK,H}$	$V_{GH,M}=V_{GH}-1.2$	2.2	-	3.6	V
FLK Low Voltage	$V_{FLK,L}$	$V_{GH,M}=V_{DD}+1.5$	0	-	0.5	V
DPM High Voltage	$V_{DPM,H}$	$V_{FLK}=0V$, $V_{GH,M}=V_{DD}$ (Application 1,3)	2.2	-	3.6	V
DPM Low Voltage	$V_{DPM,L}$	$V_{FLK}=0V$, $V_{GH,M} \leq 0.6V$ (Application 1,3)	0	-	0.5	V
DPM on Current	I_{DPM}	$V_{FLK}=3V$, $V_{GH,M}=V_{GH}$ (Application 2,3)	0.2	0.4	2	mA
RC (Resistor of V_{DPM} PIN)	R_C	$V_{GH}=22V$, $R_C=(V_{GH}-0.9)/I_{DPM}$ (Application 2,3)	10	45	100	k Ω
Output High Voltage	$V_{GH,M,H1}$	$I_O=10mA$	$V_{GH}-1.2$	$V_{GH}-0.7$	-	V
Output Reset Voltage	$V_{GH,M,R1}$	$V_{DPM}=0V$, $V_{FLK}=3V$	-	-	0.6	V
	$V_{GH,M,R2}$	$V_{DPM}=0V$, $V_{FLK}=0V$	-	-	0.6	V
Output Low Voltage	$V_{GH,M,L1}$	$V_{DPM}=3V$, $V_{FLK}=0V$, $I_O=-1mA$	V_{DD}	$V_{DD}+0.7$	$V_{DD}+1.5$	V9
Power Supply Input Current	I_{GH}	$V_{GH}=35V$, $V_{DD}=15V$, $V_{FLK}=V_{DPM}=3.3V$, $I_O=0$	-	3.5	-	mA
Reference Input Current	I_{DD}	$V_{GH}=35V$, $V_{DD}=15V$, $V_{FLK}=0$, $V_{DPM}=3.3V$, $I_O=0$	-	40	-	μA

● BLOCK DIAGRAM & TEST CIRCUIT

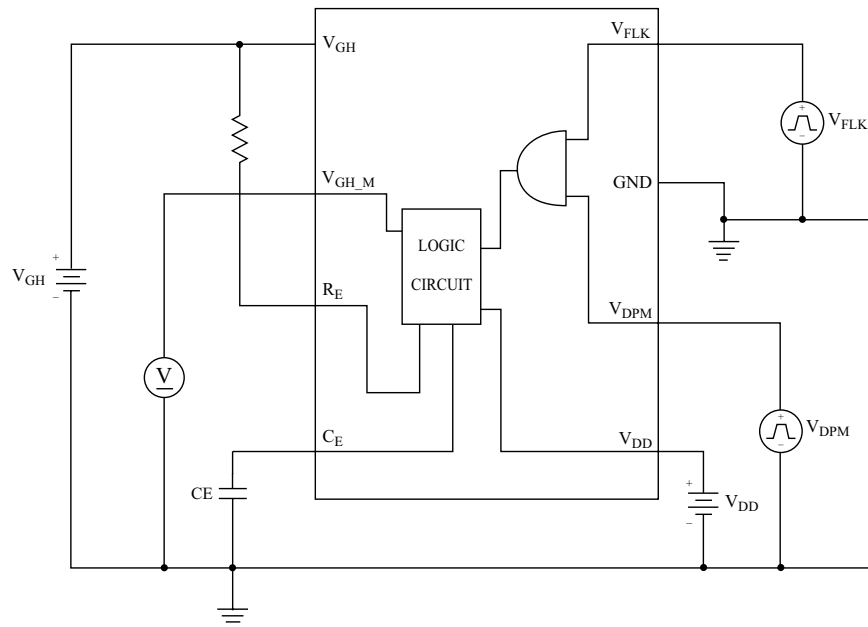

PIN CONNECTION

Pin No	1	2	3	4	5	6	7	8
KIA3820F	C_E	R_E	$V_{GH,M}$	V_{GH}	V_{FLK}	GND	V_{DPM}	V_{DD}
KIA3820FK	V_{GH}	$V_{GH,M}$	R_E	C_E	V_{DD}	V_{DPM}	GND	V_{FLK}

KIA3820F/FK

PIN FUNCTION DESCRIPTION

Pin Number (Note)	Pin Name	Pin Function	Comment
1/4	V_{GH}	Power Supply Input	$V_{GH}=15\sim 38V$
2/3	V_{GH_M}	Output	This output directly drives the power supply of Gate Driver IC
3/2	R_E	R_E pin used to decide delay time	The Delay time are programmed by connecting resistor R_E to V_{GH} and capacitor C_E to ground
4/1	C_E	C_E Pin used decide delay time	
5/8	V_{DD}	Reference Input	The reference input Pin used to reduce flicker The Reference input voltage is as follows ; $V_{DD} \leq V_{GH} - 8.5V$, $V_{DD} = 0 \sim 17V$
6/7	V_{DPM}	Signal Input 1	V_{DPM} Single input voltage is as follows ; $V_{DPM} = 0 \sim 3.6V$ V_{DPM} pin is used to prevent situation which V_{GH} , V_{GL} , V_{CC} emerging from dc/dc converter is latched up, is produced from timing controller in LCD module, determines a time which V_{GH} is on.
7/6	GND	Ground	-
8/5	V_{FLK}	Signal Input 2	V_{FLK} Single input voltage is as follows ; $V_{FLK} = 0 \sim 3.6V$ V_{FLK} determines a time which TFT LCD is on/off, is produced from timing controller in LCD module.

Note) KIA3820FK / KIA3820F

• Input & Output Characteristics Graph (Application 1)

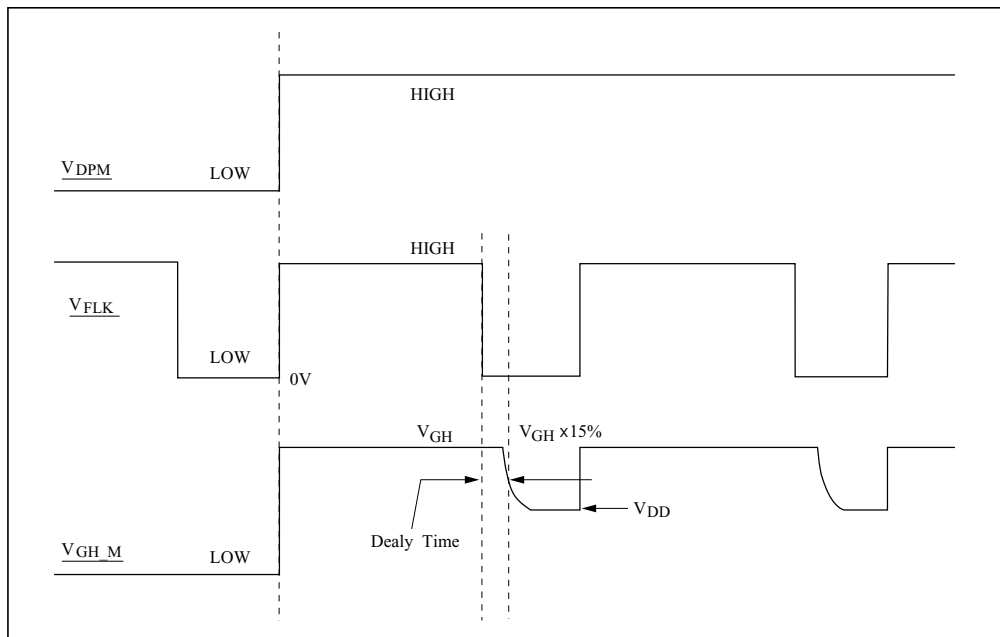

KIA3820F/FK

• Input & Output Characteristics Graph (Application 2)

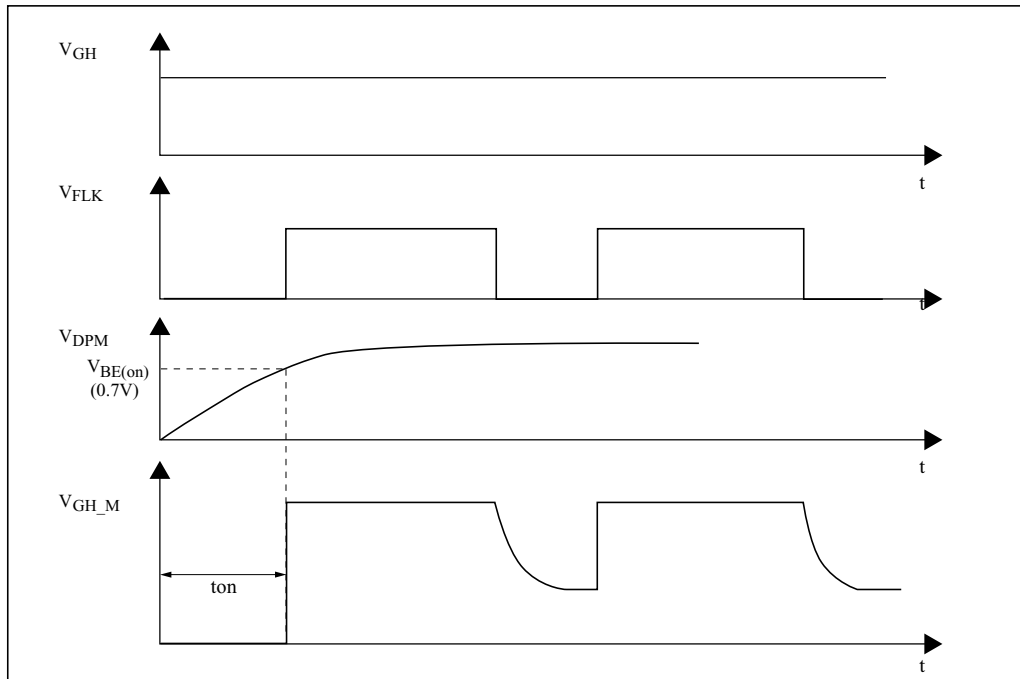

• Definition of Delay Time

- Delay time is defined as the value of V_{GH_M} is falling to 15% of that after V_{FLK} is falling to the low.

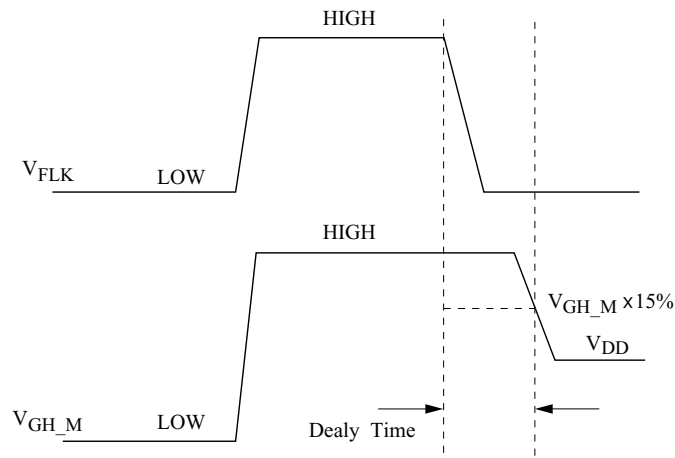

• Delay Time Characteristics Table. (Unless otherwise specifies, $V_{DPM}=3V$, $V_{FLK}=3V$, $R_E=15k\ \Omega$, $R_{E_{max}}<100k\ \Omega$)

ITEM	CONDITION	RESULT
Delay time	$V_{GH}=17V$, $V_{DD}=6.7V$, $C_E=100pF$	1.48 (μs)
	$V_{GH}=17V$, $V_{DD}=6.7V$, $C_E=240pF$	3.08 (μs)
	$V_{GH}=22.4V$, $V_{DD}=10V$, $C_E=92pF$	1.54 (μs)
	$V_{GH}=22.4V$, $V_{DD}=10V$, $C_E=226pF$	2.98 (μs)
	$V_{GH}=25.4V$, $V_{DD}=15.4V$, $C_E=56pF$	1.50 (μs)
	$V_{GH}=25.4V$, $V_{DD}=15.4V$, $C_E=139pF$	3.02 (μs)

KIA3820F/FK

APPLICATION 1

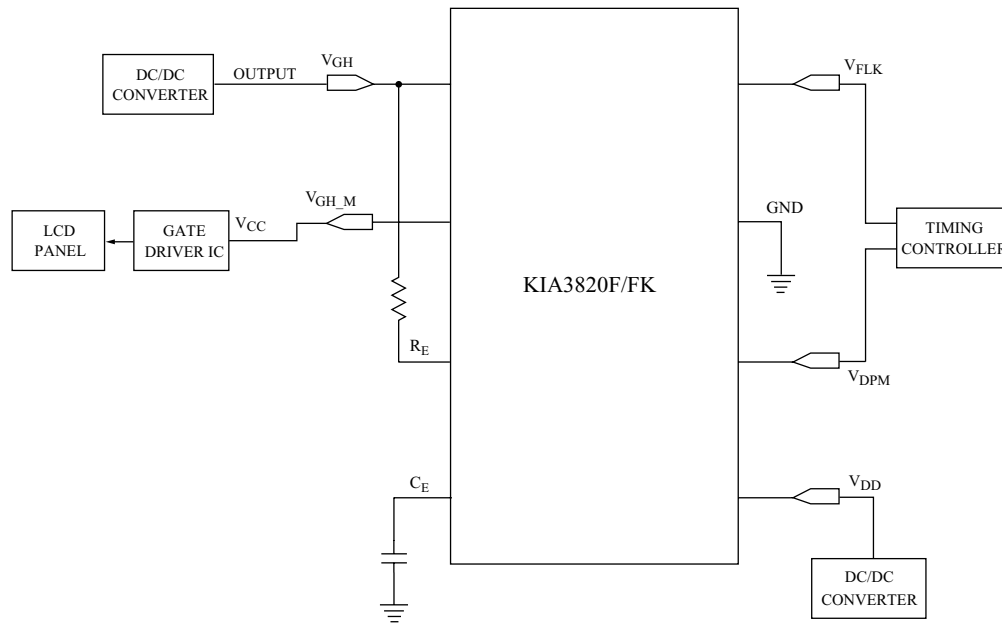

APPLICATION 2

V_{DPM} signal is produced by connecting resistor R_C to V_{GH} and capacitor C_D to ground. R_D used to discharge when V_{GH} signal is low voltage.

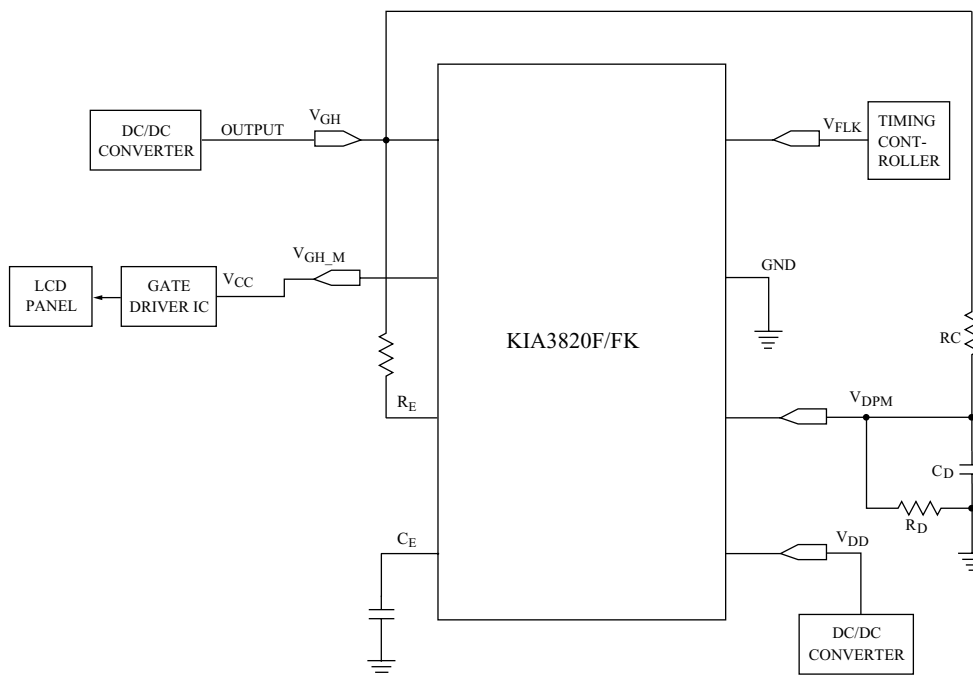

KIA3820F/FK

• V_{GH_M} Signal Delay Time Characteristics Table.

V _{GH} [V]	V _{DD} [V]	C _D [μ F]	R _D [k Ω]	R _C [k Ω]	V _{GH_M} on delay time (when V _{GH} is on) ton (ms)	V _{DPM} pin discharge time (when V _{GH} is off) toff (ms)
22	12	1	2	50	3.4	4
		1	0.8	20	1.8	1.6
		1	0.4	10	1	0.8

• Function Description

name	Comment	Function
R _C	R _C & C _D determines a time which V _{DPM} pin is charge	t _{on} : The time which V _{GH_M} is high $t_{on} \doteq (0.14 \times C_D \times R_C \times C_D) / ((R_D \times (V_{GH}-0.7)) - (0.7 \times R_C))$ $R_D \geq R_C \times (0.9 / (V_{GH}-0.9))$
C _D		t _{off} : The time which V _{DPM} pin is full discharge $t_{off} \doteq 2 \times R_D \times C_D$
R _D	R _D determines a time which V _{DPM} pin is discharge	R _{Cmin} = (V _{GH} -0.9)/2mA R _{Cmax} = (V _{GH} -0.9)/200 μ A

APPLICATION 3

If there is no use to V_{DPM} terminal function which suggested in APPLICATION 1 and 2, USE the following APPLICATION3. Also, V_{DD} Voltage is possible to use Voltage which is divided V_{GH} Voltage, so we don't use to external power supply. This method is possible to apply APPLICATION 1 and 2.

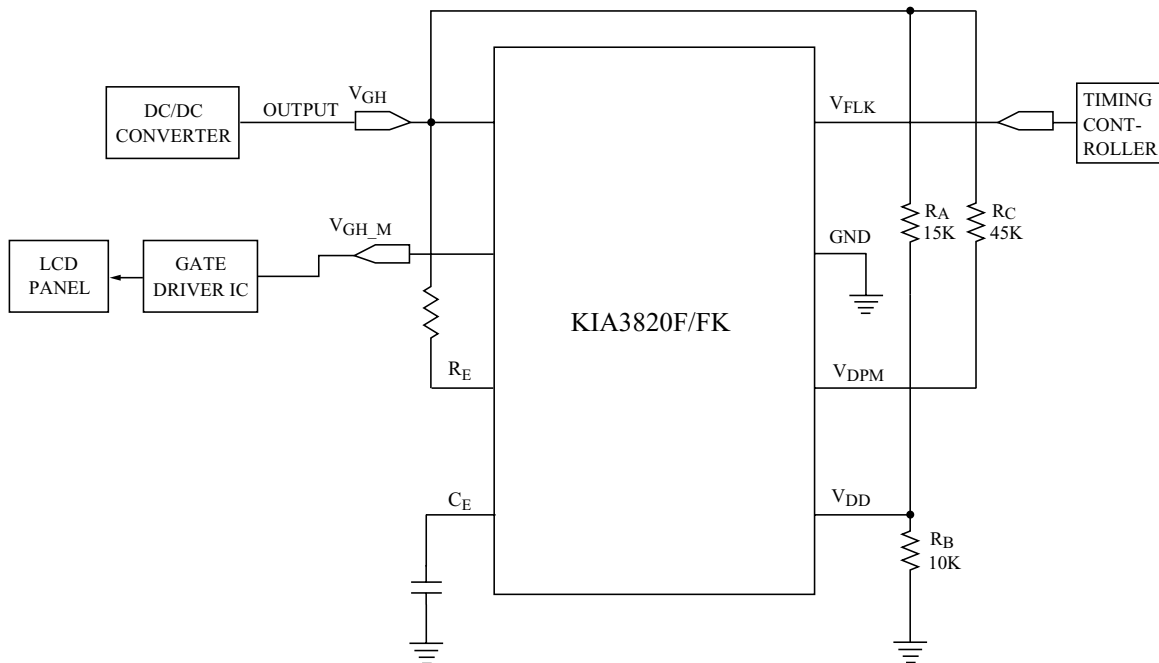

KIA3820F/FK

• Function Description

name	Comment	Function
R _A	R _A & R _B determines a V _{DD} Voltage.	$V_{DD} = V_{GH} \times (R_B / (R_A + R_B))$
R _B		
R _C	R _C is used to determine Voltage that V _{DPM} pin becomes high	$(V_{GH} - 0.9) / 2mA < R_C < ((V_{GH} - 0.9) / 0.2mA)$

• APPLICATION SYSTEM BLOCK DIAGRAM

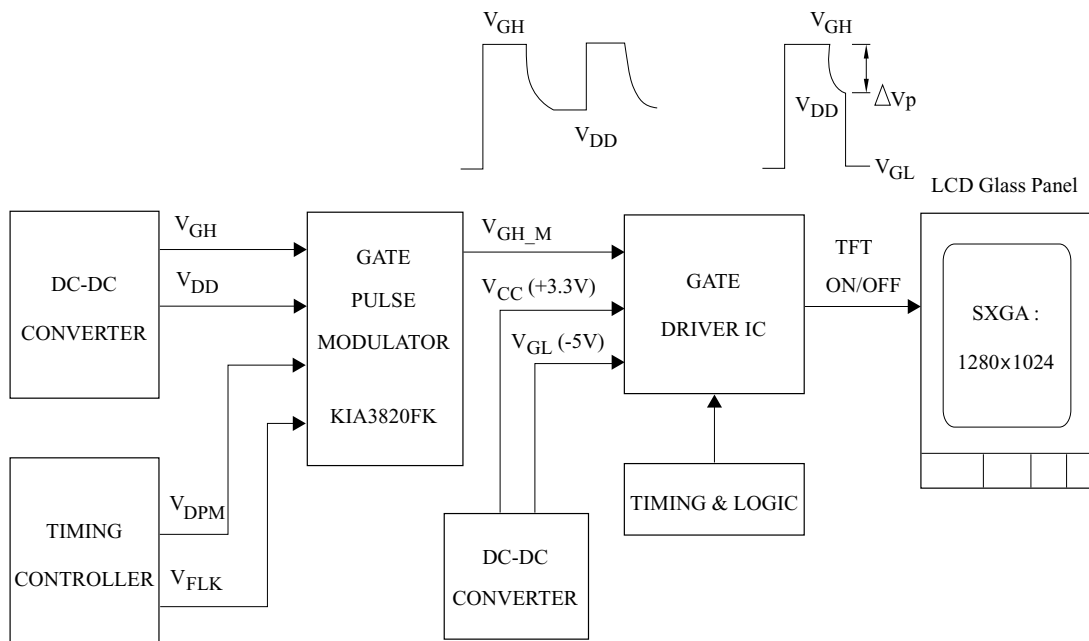

note) ΔV_p is decreasing more and more, Flick is reduced from LCD panel