

### HIGH PERFORMANCE CURRENT MODE CONTROLLER

The KIA3842/3/4/5AP/AF are high performance fixed frequency current mode controller. This is specifically designed for Off-Line and DC to DC converter applications offering the designer a cost effective solution with minimal external components. This integrated circuit feature a trimmed oscillator for precise duty cycle control, a temperature compensated reference, high gain error amplifier, current sensing comparator, and a high current totempole output ideally suited for driving a power MOSFET. Also included are protective features consisting of input and reference undervoltage lockouts each with hysteresis, cycle-by-cycle current limiting, programmable output deadtime, and a latch for single pulse metering. Differences between members of this family are the under-voltage lockout thresholds and maximum duty cycle ranges. The KIA3842A and KIA3844A have UVLO thresholds of 16V(on) and 10V(off), ideally suited off-line applications. The corresponding thresholds for the KIA3843A and KIA3845A are 8.5V and 7.9V. The KIA3842A and KIA3843A can operate to duty cycles approaching 100%. A range of the zero to <50% is obtained by the KIA3844A and KIA3845A by the addition of an internal toggle flip flop which balanks the output off every other clock cycle.

### FEATURES

- Trimmed Oscillator Discharge Current for Precise Duty Cycle Control.
- Current Mode Operation to 500kHz.
- Automatic Feed Forward Compensation.
- Latching PWM for Cycle-By-Cycle Current Limiting.
- Internally Trimmed Reference with Undervoltage Lockout.
- High Current TotemPole Output.
- Undervoltage Lockout with Hysteresis.
- Low Start-up and Operating Current 0.2mA(Typ.)

### MAXIMUM RATING (Ta=25°C)

CHARACTERISTIC	SYMBOL	RATING	UNIT
Supply Voltage	V <sub>CC</sub>	30	V
Output Current, Source or Sink (Note 1)	I <sub>O</sub>	1.0	A
Output Energy (Capacitive Load Per Cycle)	W	5.0	μJ
Analog Inputs (Pin ②, ③)	V <sub>IN</sub>	-0.3 to + 6.3	V
Error Amp Output Sink Current	I <sub>O</sub>	10	mA
Power Dissipation	P <sub>D</sub>	1.25	W
		800	mW
Operating Temperature	T <sub>a</sub>	0 to + 70	°C
Storage Temperature	T <sub>stg</sub>	-65 to + 150	°C

NOTE : 1. Maximum package power dissipation limits must be observed.

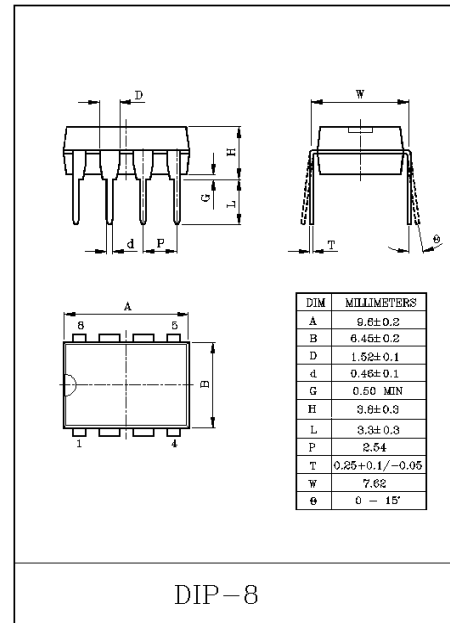

DIP-8

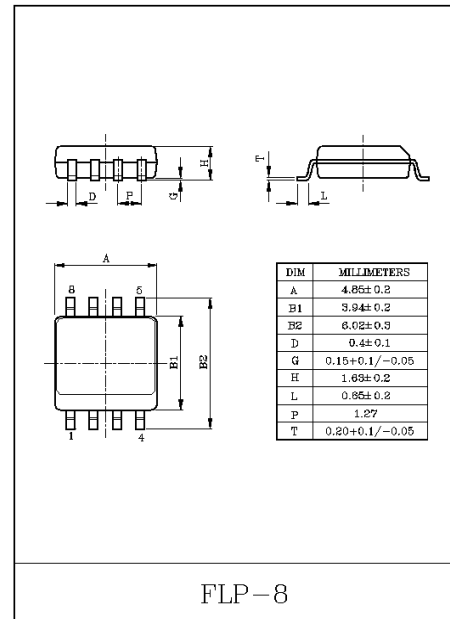

FLP-8

# KIA3842/3/4/5AP/AF

## PIN CONNECTIONS (TOP VIEW)

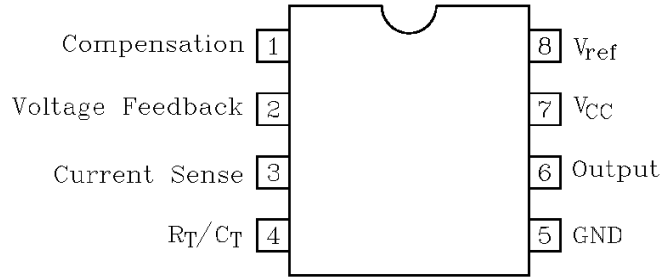

## BLOCK DIAGRAM

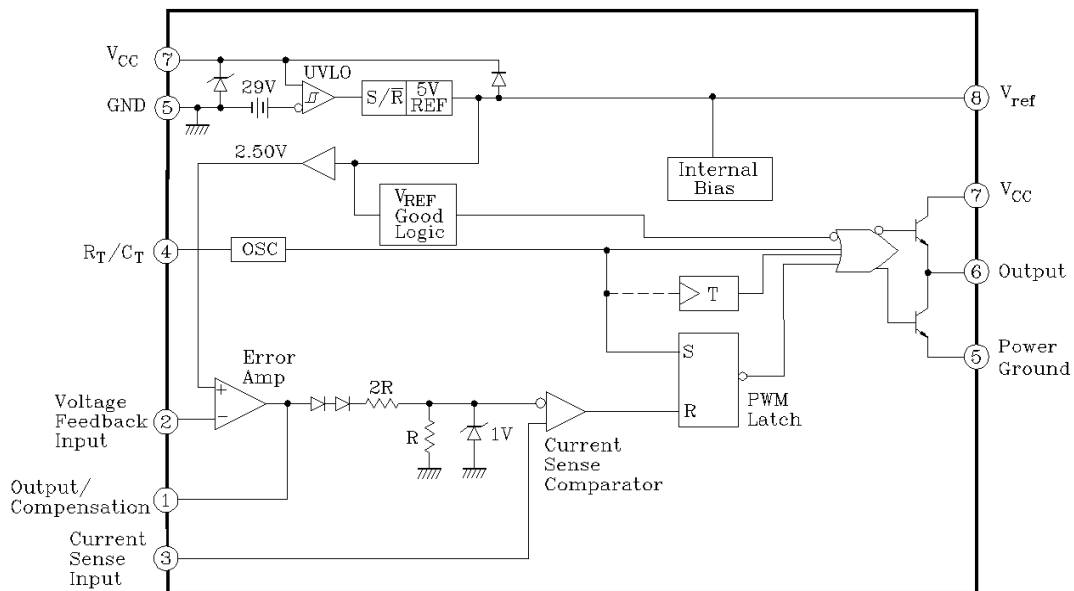

# KIA3842/3/4/5AP/AF

ELECTRICAL CHARACTERISTICS ( $V_{CC}=15V$  (Note 2),  $R_T=10k\Omega$ ,  $C_T=3.3nF$ ,  $T_a=25^\circ C$ )

## REFERENCE SECTION

CHARACTERISTIC	SYMBOL	TEST CONDITION	MIN.	TYP.	MAX.	UNIT
Reference Output Voltage	$V_{ref}$	$I_O=1.0mA$ , $T_a=25^\circ C$	4.9	5.0	5.1	V
Line Regulation	$Reg_{line}$	$12V \leq V_{IN} \leq 25V$	-	2.0	20	mV
Load Regulation	$Reg_{load}$	$1mA \leq I_O \leq 20mA$	-	3.0	25	mV
Temperature Stability	$T_S$	-	-	0.2	-	mV/ $^\circ C$
Total Output Variation over Line, Load, and Temperature	$V_{ref}$	-	4.82	-	5.18	V
Output Noise Voltage	$V_{no}$	$10Hz \leq f \leq 10kHz$ , $T_a=25^\circ C$	-	50	-	$\mu V$
Long Term Stability	S	$T_a=125^\circ C$ , 1000Hrs	-	5.0	-	mV
Output Short Circuit Current	$I_{SC}$	-	-30	-85	-180	mA

## OSCILLATOR SECTION

CHARACTERISTIC	SYMBOL	TEST CONDITION	MIN.	TYP.	MAX.	UNIT
Frequency	$f_{osc}$	$T_a=25^\circ C$	47	52	57	kHz
Frequency Change With Voltage	$\Delta f_{osc}/\Delta V$	$12V \leq V_{CC} \leq 25V$	-	0.2	1.0	%
Frequency Change With Temperature	$\Delta f_{osc}/\Delta T$	$0 \leq T_a \leq 70^\circ C$	-	5.0	-	%
Oscillator Voltage Swing	$V_{OSC}$	4 PIN Peak to Peak	-	1.7	-	V
Discharge Current	$I_{dischg}$	$V_{PIN4}=2V$	7.8	8.3	8.8	mA

## ERROR AMPLIFIER SECTION

CHARACTERISTIC	SYMBOL	TEST CONDITION	MIN.	TYP.	MAX.	UNIT
Voltage Feedback Input	$V_{FB}$	$V_{PIN1}=2.5V$	2.42	2.5	2.58	V
Input Bias Current	$I_{IB}$	-	-	-0.3	-2.0	$\mu A$
Open-Loop Voltage Gain	$A_{VOL}$	$2V \leq V_O \leq 4V$	65	90	-	$\mu A$
Unity Gain Bandwidth	BW	$T_a=25^\circ C$	0.7	1.0	-	MHz
Power Supply Rejection Ratio	PSRR	$12V \leq V_{CC} \leq 25V$	60	70	-	dB
Output Sink Current	$I_{sink}$	$V_{PIN2}=2.7V$ , $V_{PIN1}=1.1V$	2.0	12	-	mA
Output Source Current	$I_{source}$	$V_{PIN2}=2.3V$ , $V_{PIN1}=5V$	-0.5	-0.8	-	
Vout High	$V_{OH}$	$R_L=15k$ to GND, $V_{PIN2}=2.3V$	5.0	6.0	-	V
Vout Low	$V_{OL}$	$R_L=15k$ to Ref, $V_{PIN2}=2.7V$	-	0.7	1.1	

## CURRENT SENSE SECTION

CHARACTERISTIC	SYMBOL	TEST CONDITION	MIN.	TYP.	MAX.	UNIT
Current Sense Input Voltage Gain	$A_V$	$V_{FB}=0$ , $V_{IN}=0 \sim 0.8V$ $A_V = \frac{\Delta V \text{ output Compensation}}{\Delta V \text{ Current Sense Input}}$	2.85	3.0	3.15	V/V
Maximum Current Sense Input Threshold	$V_{th}$	$V_{PIN1}=5V$ , $V_{PIN2}=0V$	0.9	1.0	1.1	V
Power Supply Rejection Ratio	PSRR	$12V \leq V_{CC} \leq 25V$ , $V_{PIN2}=0V$	-	70	-	dB
Input Bias Current	$I_{IB}$	-	-	-2.0	-10	$\mu A$
Propagation Delay	$t_{PLH(IN/OUT)}$	Current Sense Input to Output, $V_{PIN3}=0$ to 2V	-	100	200	nS

# KIA3842/3/4/5AP/AF

## OUTPUT SECTION

CHARACTERISTIC	SYMBOL	TEST CONDITION	MIN.	TYP.	MAX.	UNIT
Low State Output Voltage	$V_{OL}$	$I_{sink}=20mA$	-	0.1	0.4	V
		$I_{sink}=200mA$	-	1.5	2.2	
High State Output Voltage	$V_{OH}$	$I_{source}=20mA$	13	13.5	-	V
		$I_{source}=200mA$	12	13.5	-	
Rise Time	$t_r$	$C_L=1.0nF, V_{FB}=0$	-	40	100	nS
Fall Time	$t_f$	$C_L=1.0nF, V_{FB}=0$	-	40	100	nS
UVLO Saturation	$V_{OLS}$	$V_{CC}=6V, I_{SINK}=1mA$	-	0.7	1.2	V
Output Voltage Swing Limit	$V_{OLIM}$	$V_{CC}=27V, C_1=1nF$	-	22	-	V

## UNDER VOLTAGE LOCKOUT SECTION

CHARACTERISTIC	SYMBOL	TEST CONDITION	MIN.	TYP.	MAX.	UNIT
Start-up Threshold Voltage	$V_{TH}$	KIA3842/4A	14.5	16	17.5	V
		KIA3843/5A	7.8	8.4	9.0	
Minimum Operating Voltage	$V_{CC(min.)}$	After Turn ON				V
		KIA3842/4A	8.5	10	11.5	
		KIA3843/5A	7.0	7.6	8.2	

## PWM SECTION

CHARACTERISTIC	SYMBOL	TEST CONDITION	MIN.	TYP.	MAX.	UNIT
Duty Cycle Max.	$DC_{max.}$	KIA3842/3A	94	96	100	%
		KIA3844/5A	47	48	50	
Duty Cycle Min.	$DC_{min.}$		-	-	0	%

## TOTAL DEVICE

CHARACTERISTIC	SYMBOL	TEST CONDITION	MIN.	TYP.	MAX.	UNIT
Power Supply Current	$I_{CC}$	$V_{CC}=14V$	-	0.2	0.5	mA
		$V_{CC}=15V, \text{ after turn ON}$	-	11	17	
Power Supply Zener Voltage	$V_Z$	$I_{CC}=25mA$	-	29	-	V

# KIA3842/3/4/5AP/AF

## TEST CIRCUIT

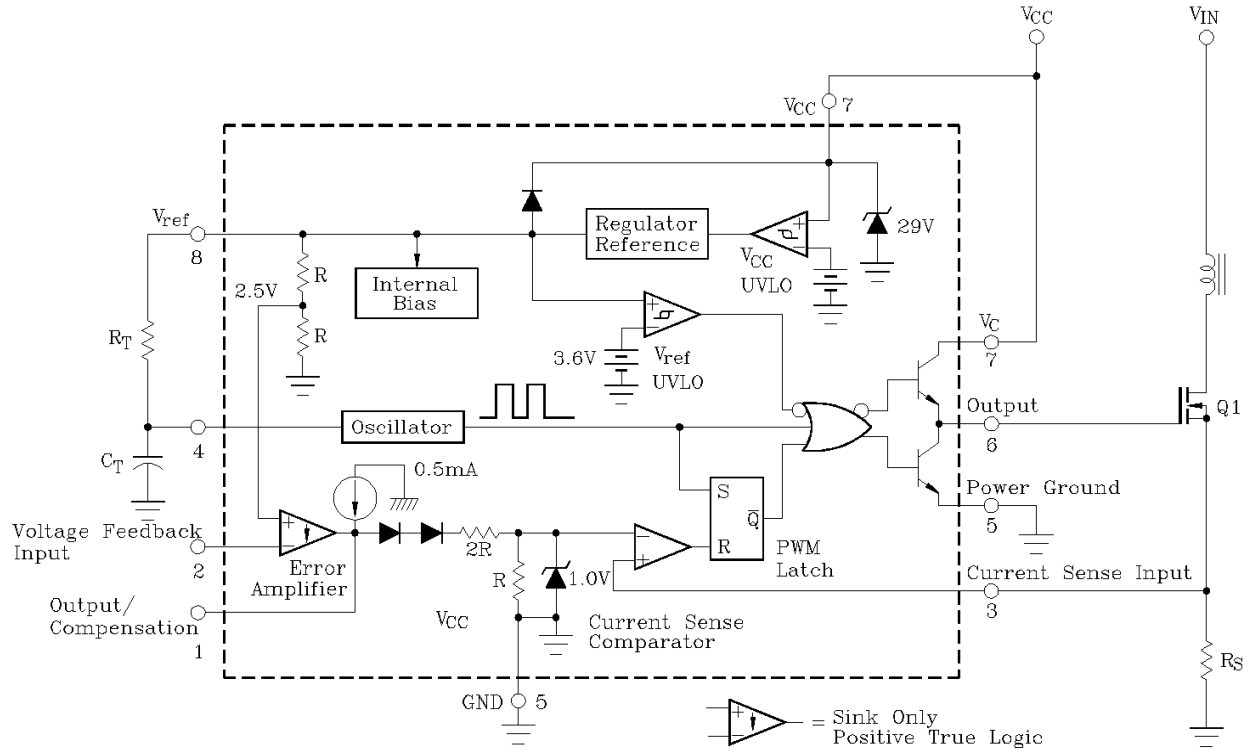

# KIA3842/3/4/5AP/AF

## PIN FUNCTION DESCRIPTION

PIN NO.	FUNCTION	DESCRIPTION
1	Compensation	This pin is the Error Amplifier output and is made available for loop compensation.
2	Voltage Feedback	This is the inverting input of the Error amplifier. It is normally connected to the switching power supply output through a resistor divider.
3	Current Sense	A voltage proportional to inductor current is connected to this input. The PWM uses this information to terminate the output switch conduction.
4	$R_T/C_T$	The Oscillator frequency and maximum Output duty Cycle are programmed by connecting resistor $R_T$ to $V_{ref}$ and capacitor $C_T$ to ground. Operation to 500kHz is possible.
5	GND	This pin is the combined control circuitry and power ground (8-pin package only).
6	Output	This output directly drives the gate of a power MOSFET. Peak currents up to 1.0A are sourced and sunk by this pin.
7	$V_{CC}$	This pin is the positive supply of the control IC.
8	$V_{ref}$	This is the reference output. It provides charging current for capacitor $C_T$ through resistor $R_T$ .

# KIA3842/3/4/5AP/AF

