

4 TERMINAL 3A OUTPUT LOW DROP VOLTAGE REGULATOR

The KIA378R × × Series are Low Drop Voltage Regulator suitable for various electronic equipments. It provides constant voltage power source with TO-220 4 terminal lead full molded PKG. The Regulator has multi function such as over current protection, overheat protection and ON/OFF control.

FEATURES

- 3.0A Output Low Drop Voltage Regulator.
- Built in ON/OFF Control Terminal.
- Built in Over Current Protection, Over Heat Protection Function.

LINE UP

ITEM	OUTPUT VOLTAGE (Typ.)	UNIT
* KIA378R25PI	2.5	V
* KIA378R30PI	3.0	
* KIA378R33PI	3.3	
* KIA378R35PI	3.5	
* KIA378R37PI	3.7	

* Note) * : Under Development.

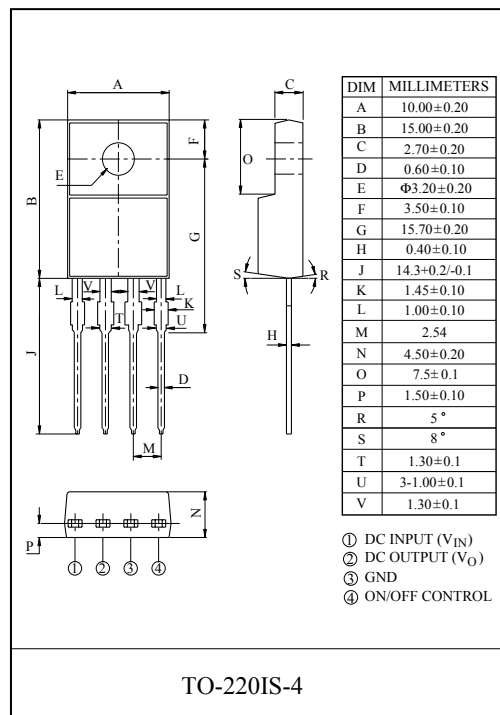

MAXIMUM RATING (Ta=25°C)

CHARACTERISTIC	SYMBOL	RATING	UNIT	Remark
Input Voltage	V _{IN}	15	V	-
ON/OFF Control Voltage	V _C	15	V	-
Output Current	I _O	3	A	-
Power Dissipation 1	P _{d1}	1.5	W	No heatsink
Power Dissipation 2	P _{d2}	15	W	with heatsink
Junction Temperature	T _j	125	°C	-
Operating Temperature	T _{opr}	-20 ~ 80	°C	-
Storage Temperature	T _{stg}	-30 ~ 125	°C	-
Soldering Temperature (10sec)	T _{sol}	260	°C	-

KIA378R25PI~KIA378R37PI

ELECTRICAL CHARACTERISTICS (Ta=25°C)

(Unless otherwise specified, I_O=1.0A, Ta=25°C, Note1.)

CHARACTERISTIC		SYMBOL	CONDITIONS	MIN.	TYP.	MAX.	UNIT
Output Voltage	KIA378R25	V _O	-	2.438	2.50	2.562	V
	KIA378R30		-	2.925	3.00	3.075	
	KIA378R33		-	3.220	3.30	3.380	
	KIA378R35		-	3.413	3.50	3.587	
	KIA378R37		-	3.608	3.70	3.792	
Load Regulation		Reg Load	I _O =5mA~3A	-	0.1	2.0	%
Line Regulation		Reg Line	(Note 2)	-	0.5	2.5	%
Temperature Coefficient of Output Voltage		T _C V _O	T _j =0~125°C	-	±0.02	±0.05	%/°C
Ripple Rejection		R · R	-	45	55	-	dB
Drop Out Voltage		V _D	I _O =3A	-	-	0.5	V
Output ON state for control Voltage		V _{C(ON)}	-	2.0	-	-	V
Output ON state for control Current		I _{C(ON)}	V _C =2.7V	-	-	20	μA
Output OFF state for control Voltage		V _{C(OFF)}	-	-	-	0.8	V
Output OFF state for control Current		I _{C(OFF)}	V _C =0.4V	-	-	-0.4	mA
Quiescent Current		I _Q	I _O =0	-	-	10	mA

Note1) V_{IN} of KIA378R25=4.2V

" KIA378R30=4.7V

" KIA378R33=5.0V

" KIA378R35=5.2V

" KIA378R37=5.4V

Note2) V_{IN} of KIA378R25=3.2~10V

" KIA378R30=3.7~10V

" KIA378R33=4.0~10V

" KIA378R35=4.2~10V

" KIA378R37=4.4~10V

Note3) At V_{IN}=0.95V_O

BLOCK DIAGRAM

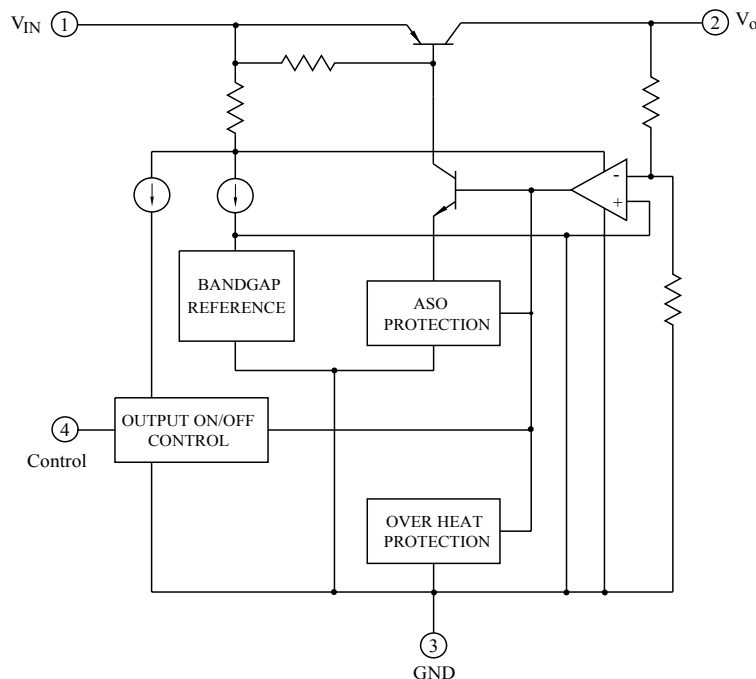

KIA378R25PI~KIA378R37PI

Fig. 1 Standard Test Circuit

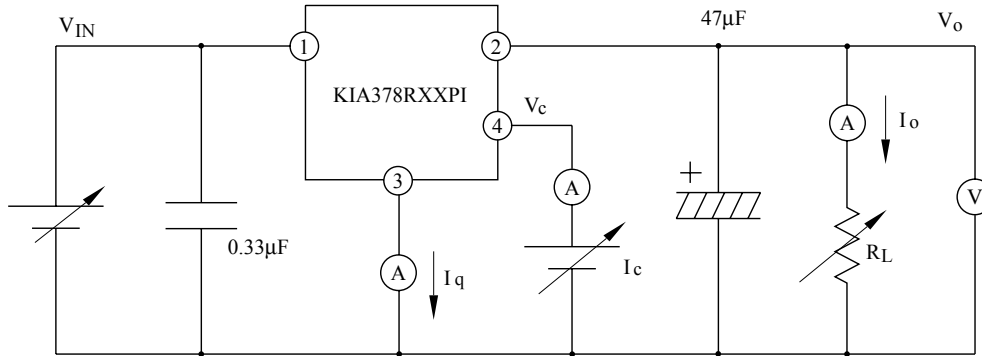

Fig. 1-2 Ripple Rejection Test Circuit

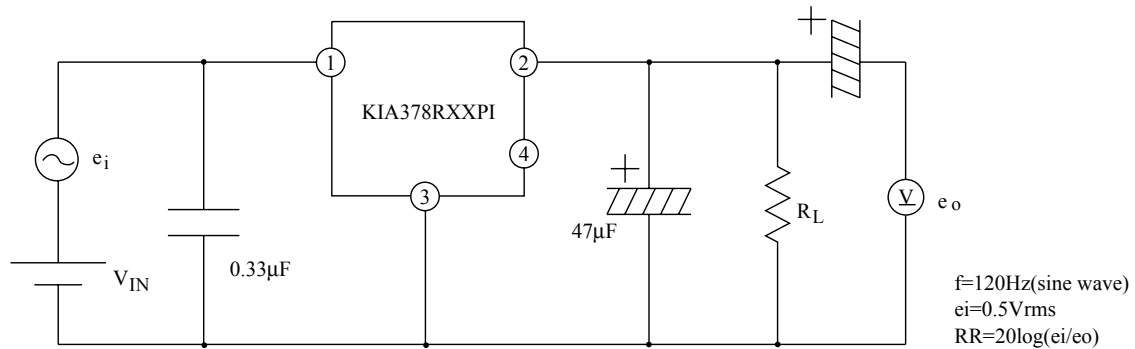
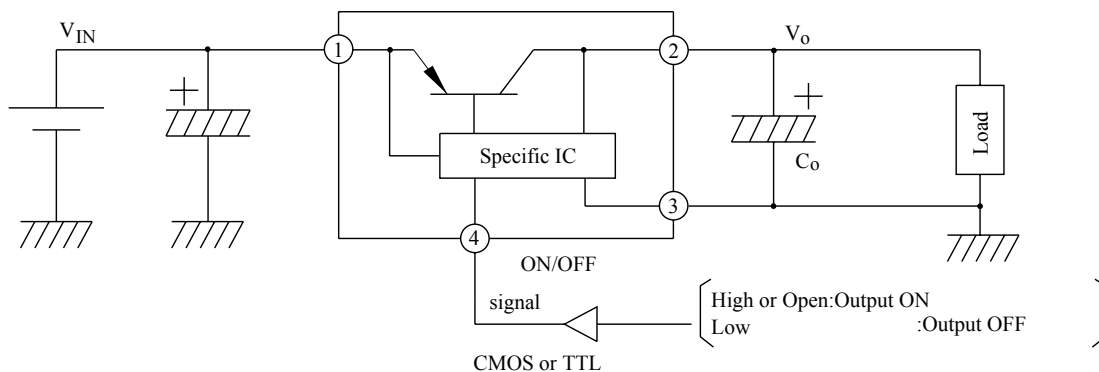
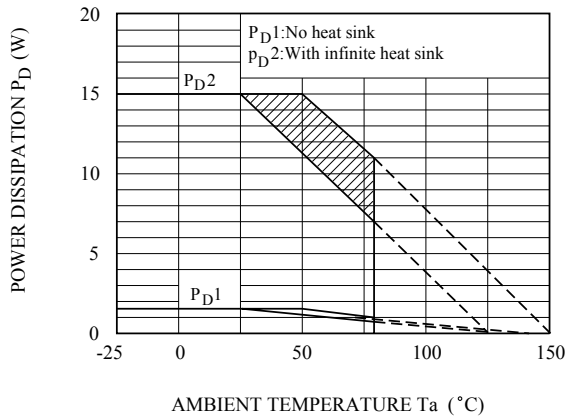

Fig. 2 Application Circuit for Standard



KIA378R25PI~KIA378R37PI

Fig.3 $T_a - P_D$



Note) Oblique line portion : Overheat protection may operate in this area.

Fig.4 $I_O - V_O$

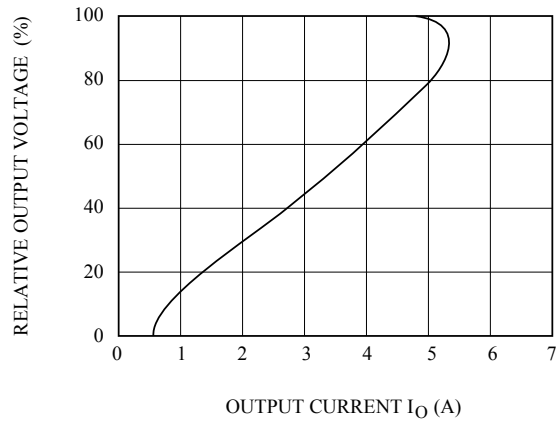

Fig.5-1 $T_j - \Delta V_O$ (KIA378R25)

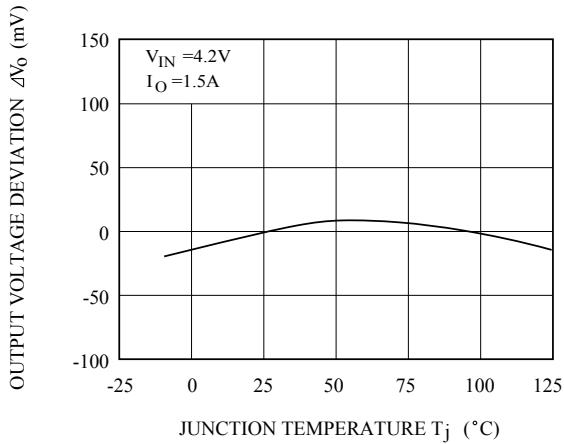

Fig.5-2 $T_j - \Delta V_O$ (KIA378R30)

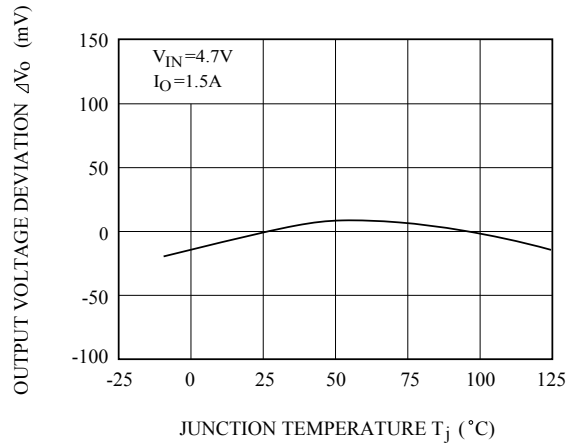

Fig.5-3 $T_j - \Delta V_O$ (KIA378R33)

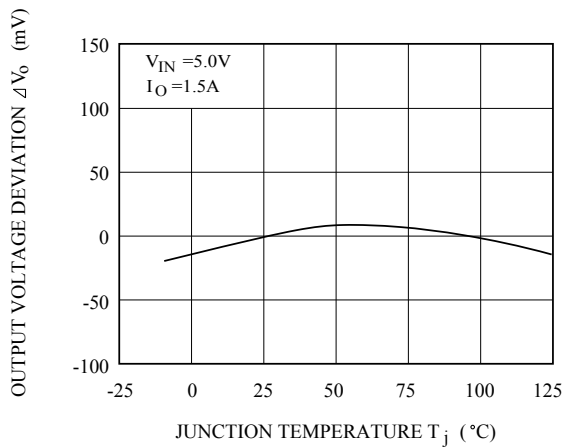
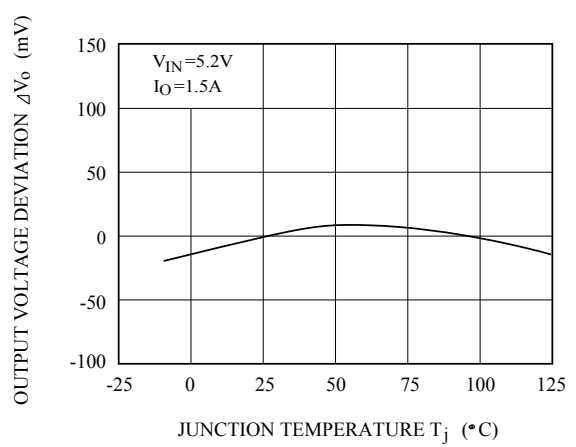

Fig.5-4 $T_j - \Delta V_O$ (KIA378R35)



KIA378R25PI~KIA378R37PI

Fig.5-1 $T_j - \Delta V_o$ (KIA378R37)

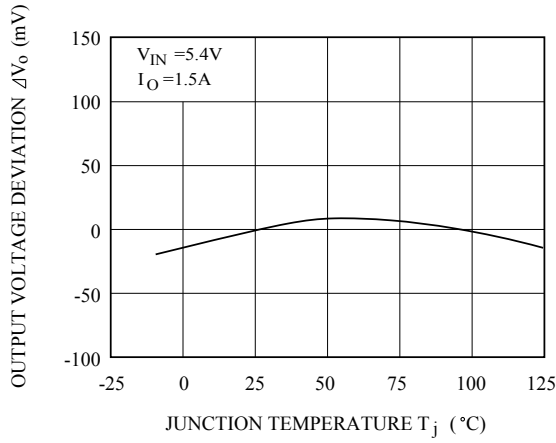

Fig.6 $T_j - V_D$

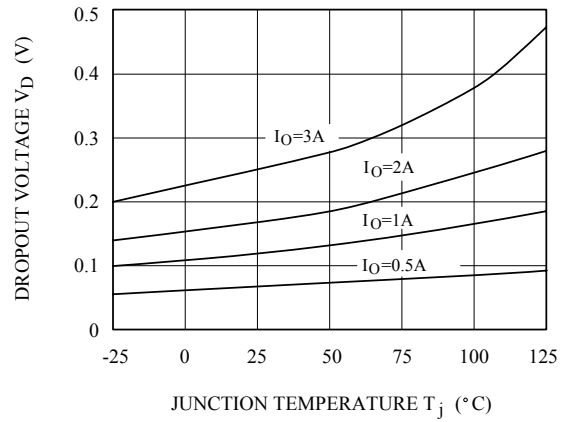

Fig.7 $T_j - I_q$

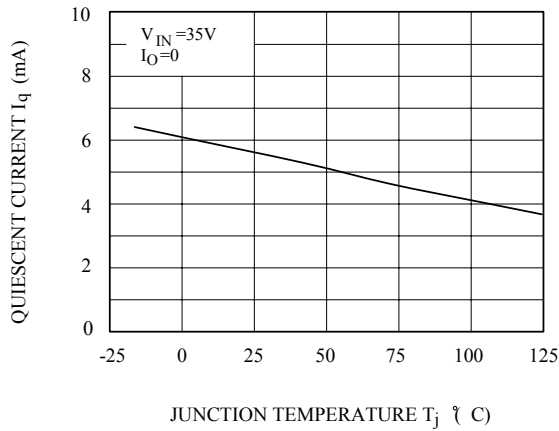

Fig.8-1 $f - RR$

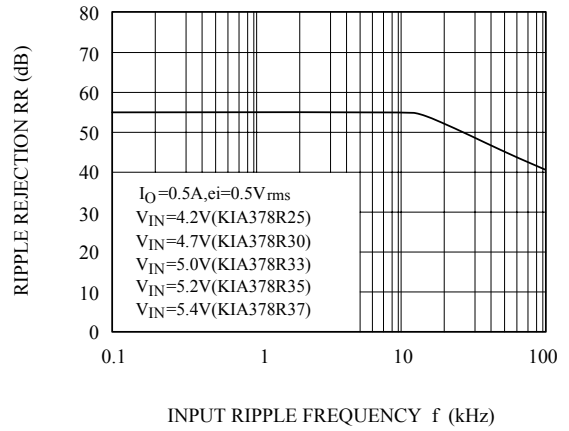

Fig.8-2 $I_O - RR$

