



Document Title

**128K x8 bit 3.3V Low Power CMOS slow SRAM**

Revision History

<u>Revision No</u>	<u>History</u>	<u>Draft Date</u>	<u>Remark</u>
10	Initial Revision History Insert	Jul.14.2000	Final
11	Change the Notch Location of sTSOP - Left-Top => Left-Center	Sep.04.2000	Final
12	Marking Information Add Revised - AC Test Condition Add : 5pF Test Load	Dec.04.2000	Final
13	Changed Logo - HYUNDAI -> hynix - Marking Information Change	Apr.30.2001	Final

## DESCRIPTION

The HY62V8100B is a high speed, low power and 1M bit CMOS SRAM organized as 131,072 words by 8bit. The HY62V8100B uses high performance CMOS process technology and designed for high speed low power circuit technology. It is particularly well suited for used in high density low power system application. This device has a data retention mode that guarantees data to remain valid at a minimum power supply voltage of 2.0V.

## FEATURES

- Fully static operation and Tri-state output
- TTL compatible inputs and outputs
- Battery backup(LL-part)
  - 2.0V(min) data retention
- Standard pin configuration
  - 32 SOP - 525mil
  - 32 TSOP-I - 8X20(Standard and Reversed)
  - 32 sTSOP-I - 8X13.4 (Standard and Reversed)

Product No.	Voltage (V)	Speed (ns)	Operation Current/I <sub>cc</sub> (mA)	Standby Current(LL)( $\mu$ A)	Temperature ( $^{\circ}$ C)
HY62V8100B	3.0~3.6	70/85/100	5	10	0~70
HY62V8100B-E	3.0~3.6	70/85/100	5	15	-25~85(E)
HY62V8100B-I	3.0~3.6	70/85/100	5	15	-40~85(I)

Note 1. Blank : Commercial, E : Extended, I : Industrial  
 2. Current value is max.

## PIN CONNECTION

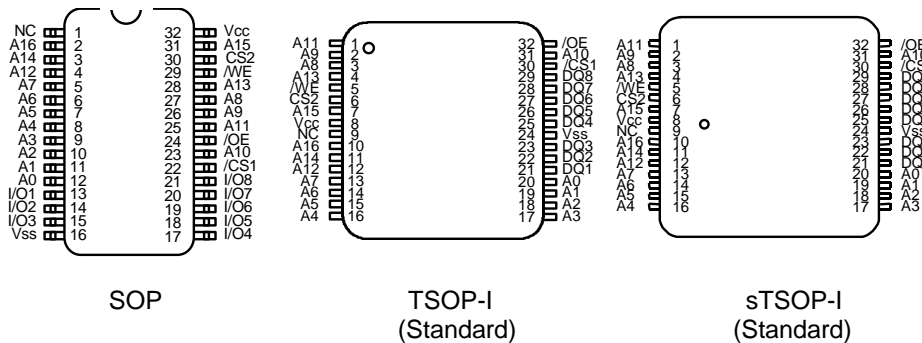

## PIN DESCRIPTION

Pin Name	Pin Function
/CS1	Chip Select 1
CS2	Chip Select 2
/WE	Write Enable
/OE	Output Enable
A0 ~ A16	Address Inputs
I/O1 ~ I/O8	Data Inputs / Outputs
V <sub>cc</sub>	Power(3.0V~3.6V)
V <sub>ss</sub>	Ground

## BLOCK DIAGRAM

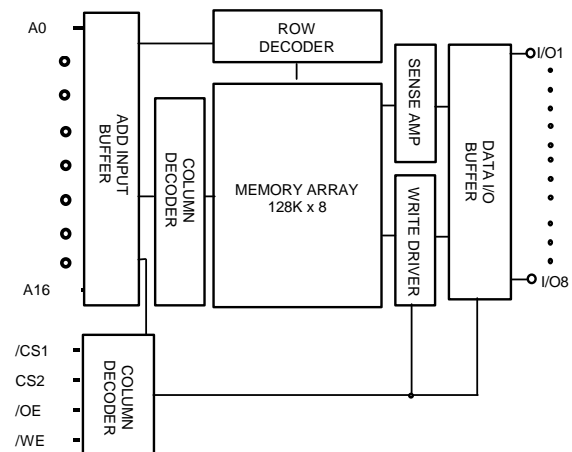

**ORDERING INFORMATION**

Part No.	Speed	Power	Temp.	Package
HY62V8100BLLG	70/85/100	LL-part		SOP
HY62V8100BLLT1	70/85/100	LL-part		TSOP-I(Standard)
HY62V8100BLLR1	70/85/100	LL-part		TSOP-I(Reversed)
HY62V8100BLLST	70/85/100	LL-part		smaller TSOP-I(Standard)
HY62V8100BLLSR	70/85/100	LL-part		smaller TSOP-I(Reversed)
HY62V8100BLLG-E	70/85/100	LL-part	E	SOP
HY62V8100BLLT1-E	70/85/100	LL-part	E	TSOP-I(Standard)
HY62V8100BLLR1-E	70/85/100	LL-part	E	TSOP-I(Reversed)
HY62V8100BLLST-E	70/85/100	LL-part	E	smaller TSOP-I(Standard)
HY62V8100BLLSR-E	70/85/100	LL-part	E	smaller TSOP-I(Reversed)
HY62V8100BLLG-I	70/85/100	LL-part	I	SOP
HY62V8100BLLT1-I	70/85/100	LL-part	I	TSOP-I(Standard)
HY62V8100BLLR1-I	70/85/100	LL-part	I	TSOP-I(Reversed)
HY62V8100BLLST-I	70/85/100	LL-part	I	smaller TSOP-I(Standard)
HY62V8100BLLSR-I	70/85/100	LL-part	I	smaller TSOP-I(Reversed)

Note 1. Blank : Commercial, E : Extended, I : Industrial

**ABSOLUTE MAXIMUM RATING (1)**

Symbol	Parameter	Rating	Unit	Remark
V <sub>CC</sub> , V <sub>IN</sub> , V <sub>OUT</sub>	Power Supply, Input/Output Voltage	-0.3 to 4.6	V	
T <sub>A</sub>	Operating Temperature	0 to 70	°C	HY62V8100B
		-25 to 85	°C	HY62V8100B-E
		-40 to 85	°C	HY62V8100B-I
T <sub>STG</sub>	Storage Temperature	-65 to 125	°C	
P <sub>D</sub>	Power Dissipation	1.0	W	
I <sub>OUT</sub>	Data Output Current	50	mA	
T <sub>SOLDER</sub>	Lead Soldering Temperature & Time	260 • 10	°C•sec	

Note

- Stresses greater than those listed under ABSOLUTE MAXIMUM RATINGS may cause permanent damage to the device. This is stress rating only and the functional operation of the device under these or any other conditions above those indicated in the operation of this specification is not implied. Exposure to the absolute maximum rating conditions for extended period may affect reliability.

**TRUTH TABLE**

/CS1	CS2	/WE	/OE	Mode	I/O	Power
H	X	X	X	Deselected	High-Z	Standby
X	L	X	X	Deselected	High-Z	Standby
L	H	H	H	Output Disabled	High-Z	Active
L	H	H	L	Read	Data Out	Active
L	H	L	X	Write	Data In	Active

Note :

- H=V<sub>IH</sub>, L=V<sub>IL</sub>, X=don't care( V<sub>IH</sub> or V<sub>IL</sub> )

**RECOMMENDED DC OPERATING CONDITION**

Symbol	Parameter	Min.	Typ.	Max.	Unit
V <sub>CC</sub>	Supply Voltage	3.0	3.3	3.6	V
V <sub>SS</sub>	Ground	0	0	0	V
V <sub>IH</sub>	Input High Voltage	2.2	-	V <sub>CC</sub> +0.3	V
V <sub>IL</sub>	Input Low Voltage	-0.3(1)	-	0.6	V

Note :

1. V<sub>IL</sub> = -1.5V for pulse width less than 30ns and not 100% tested

**DC ELECTRICAL CHARACTERISTICS**

V<sub>CC</sub> = 3.0V~3.6V, T<sub>A</sub> = 0°C to 70°C / -25°C to 85°C (E) / -40; 0 to 85; (I), unless otherwise specified

Symbol	Parameter	Test Condition	Min.	Typ.	Max.	Unit	
I <sub>LI</sub>	Input Leakage Current	V <sub>SS</sub> ≤ V <sub>IN</sub> ≤ V <sub>CC</sub>	-1	-	1	uA	
I <sub>LO</sub>	Output Leakage Current	V <sub>SS</sub> ≤ V <sub>OUT</sub> ≤ V <sub>CC</sub> , /CS1 = V <sub>IH</sub> or CS2 = V <sub>IL</sub> or /OE = V <sub>IH</sub> or /WE = V <sub>IL</sub>	-1	-	1	uA	
I <sub>CC</sub>	Operating Power Supply Current	/CS1 = V <sub>IL</sub> , CS2 = V <sub>IH</sub> , V <sub>IN</sub> = V <sub>IH</sub> or V <sub>IL</sub> , I <sub>I/O</sub> = 0mA	-	-	5	mA	
I <sub>CC1</sub>	Average Operating Current	/CS1 = V <sub>IL</sub> , CS2 = V <sub>IH</sub> , V <sub>IN</sub> = V <sub>IH</sub> or V <sub>IL</sub> Cycle Time = Min, 100% duty, I <sub>I/O</sub> = 0mA	-	-	35	mA	
I <sub>SB</sub>	TTL Standby Current (TTL Input)	/CS1 = V <sub>IH</sub> or CS2 = V <sub>IL</sub> , V <sub>IN</sub> = V <sub>IH</sub> or V <sub>IL</sub>	-	-	0.5	mA	
I <sub>SB1</sub>	Standby Current (CMOS Input)	HY62V8100B	/CS1 ≥ V <sub>CC</sub> - 0.2V or CS2 ≤ 0.2V,	-	0.5	10	uA
		HY62V8100B-E	V <sub>IN</sub> ≥ V <sub>CC</sub> - 0.2V or	-	0.5	15	uA
		HY62V8100B-I	V <sub>IN</sub> ≤ V <sub>SS</sub> + 0.2V	-	0.5	15	uA
V <sub>OL</sub>	Output Low Voltage	I <sub>OL</sub> = 2.1mA	-	-	0.4	V	
V <sub>OH</sub>	Output High Voltage	I <sub>OH</sub> = -1mA	2.2	-	-	V	

Note : Typical values are at V<sub>CC</sub> = 3.3V, T<sub>A</sub> = 25°C

**CAPACITANCE**

(Temp = 25°C, f= 1.0MHz)

Symbol	Parameter	Condition	Max.	Unit
C <sub>IN</sub>	Input Capacitance	V <sub>IN</sub> = 0V	6	pF
C <sub>OUT</sub>	Output Capacitance	V <sub>I/O</sub> = 0V	8	pF

Note : These parameters are sampled and not 100% tested

**AC CHARACTERISTICS**

V<sub>CC</sub> = 3.0V~3.6V, T<sub>A</sub> = 0°C to 70°C / -25°C to 85°C (E) / -25; 10 to 85; 1), unless otherwise specified

#	Symbol	Parameter	-70		-85		-10		Unit
			Min.	Max.	Min.	Max.	Min	Max.	
READ CYCLE									
1	tRC	Read Cycle Time	70	-	85	-	100	-	ns
2	tAA	Address Access Time	-	70	-	85	-	100	ns
3	tACS	Chip Select Access Time	-	70	-	85	-	100	ns
4	tOE	Output Enable to Output Valid	-	40	-	45	-	50	ns
5	tCLZ	Chip Select to Output in Low Z	10	-	10	-	10	-	ns
6	tOLZ	Output Enable to Output in Low Z	5	-	5	-	5	-	ns
7	tCHZ	Chip Deselection to Output in High Z	0	30	0	30	0	30	ns
8	tOHZ	Out Disable to Output in High Z	0	30	0	30	0	30	ns
9	tOH	Output Hold from Address Change	10	-	10	-	15	-	ns
WRITE CYCLE									
10	tWC	Write Cycle Time	70	-	85	-	100	-	ns
11	tCW	Chip Selection to End of Write	60	-	70	-	80	-	ns
12	tAW	Address Valid to End of Write	60	-	70	-	80	-	ns
13	tAS	Address Set-up Time	0	-	0	-	0	-	ns
14	tWP	Write Pulse Width	50	-	55	-	75	-	ns
15	tWR	Write Recovery Time	0	-	0	-	0	-	ns
16	tWHZ	Write to Output in High Z	0	25	0	30	0	35	ns
17	tDW	Data to Write Time Overlap	30	-	40	-	45	-	ns
18	tDH	Data Hold from Write Time	0	-	0	-	0	-	ns
19	tOW	Output Active from End of Write	5	-	5	-	10	-	ns

**AC TEST CONDITIONS**

T<sub>A</sub> = 0°C to 70°C / -25°C to 85°C (E) / -25; 10 to 85; 1), unless otherwise specified

Parameter		Value
Input Pulse Level		0.4V to 2.2V
Input Rise and Fall Time		5ns
Input and Output Timing Reference Level		1.5V
Output Load	tCLZ,tOLZ,tCHZ,tOHZ,tWHZ	CL = 5pF + 1TTL Load
	Others	CL = 100pF + 1TTL Load

**AC TEST LOADS**

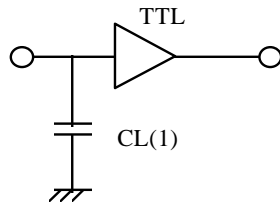

Note : 1 Including jig and scope capacitance

**TIMING DIAGRAM**

READ CYCLE 1(Note 1,4)

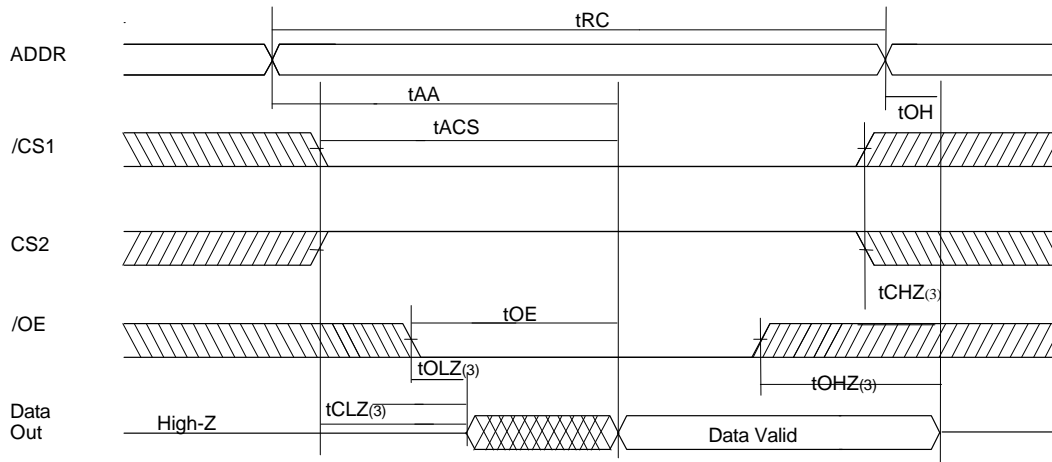

READ CYCLE 2(Note 1,2,4)

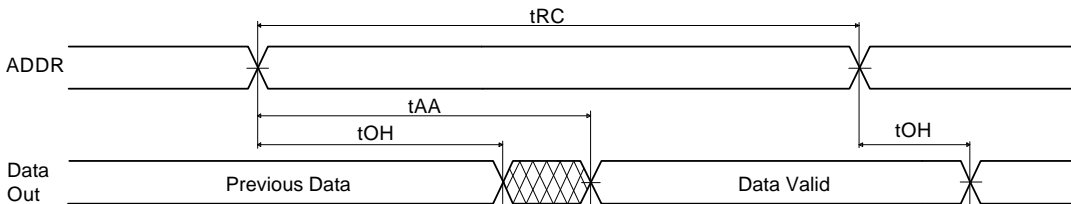

READ CYCLE 3(Note 1,2,4)

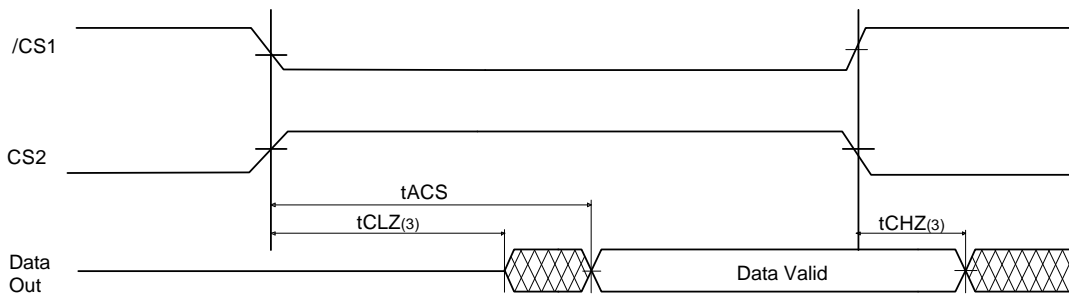

**Notes:**

1. A read occurs during the overlap of a low /OE, a high /WE, a low /CS1 and a high CS2.
2. /OE = V<sub>IL</sub>
3. Transition is measured  $\pm 200\text{mV}$  from steady state voltage.  
This parameter is sampled and not 100% tested.
4. /CS1 in high for the standby, low for active  
CS2 in low for the standby, high for active

WRITE CYCLE 1(1,4,5,8) (/WE Controlled)

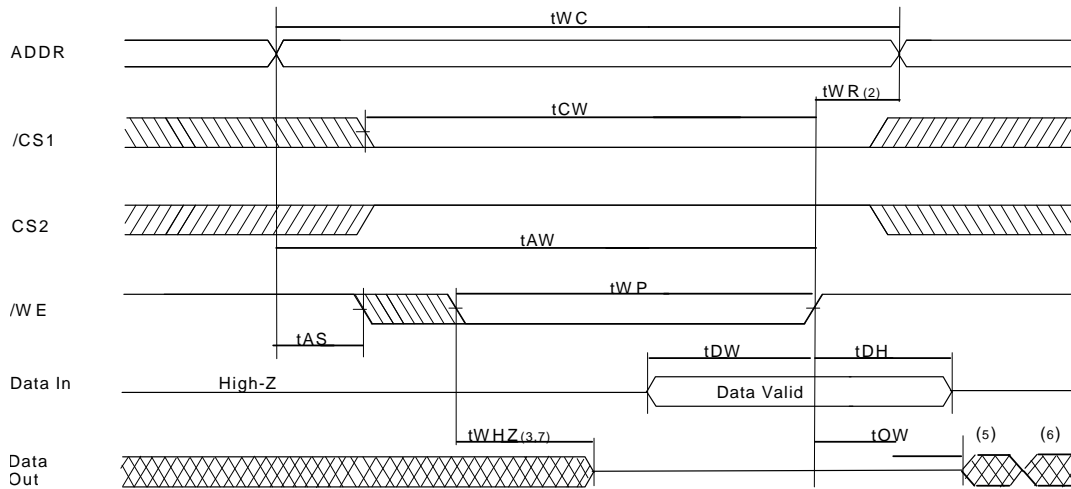

WRITE CYCLE 2 (Note 1,4,5,8) (/CS1, CS2 Controlled)

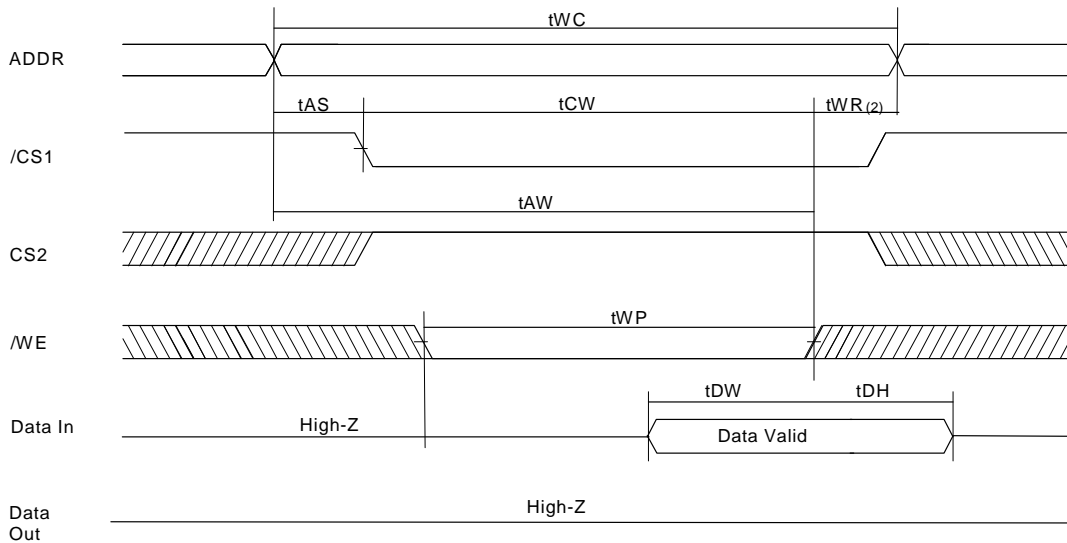

Notes:

1. A write occurs during the overlap of a low /WE, a low /CS1 and a high CS2.
2. tWR is measured from the earlier of /CS1 or /WE going high or CS2 going low to the end of write cycle.
3. During this period, I/O pins are in the output state so that the input signals of opposite phase to the output must not be applied.
4. If the the /CS1 low transition and CS2 high transition occur simultaneously with the /WE low transition or after the /WE transition, outputs remain in a high impedance state.
5. Q(data out) is the same phase with the write data of this write cycle.
6. Q(data out) is the read data of the next address.
7. Transition is measured  $\pm 200\text{mV}$  from steady state.  
This parameter is sampled and not 100% tested.
8. /CS1 in high for the standby, low for active  
CS2 in low for the standby, high for active

**DATA RETENTION ELECTRIC CHARACTERISTIC**

TA=0°C to 70°C / -25°C to 85°C (E) / -25; 85; 91

Sym	Parameter		Test Condition	Min	Typ	Max	Unit
VDR	Vcc for Data Retention		/CS1 ≥ Vcc-0.2V or CS2 ≤ 0.2V, VIN ≥ Vcc-0.2V or VIN ≤ Vss+0.2V	2.0	-	-	V
ICCDR	Data Retention Current	HY62V8100B	Vcc=3.0V,	-	0.5	10	uA
		HY62V8100B-E	/CS1 ≥ Vcc - 0.2V or CS2 ≤ 0.2V,	-	0.5	15	uA
		HY62V8100B-I	VIN ≥ Vcc-0.2V or VIN ≤ Vss+0.2V	-	0.5	15	uA
tCDR	Chip Deselect to Data Retention Time		See Data Retention Timing Diagram	0	-	-	ns
tR	Operating Recovery Time			tRC(2)	-	-	ns

Notes:

1. Typical values are under the condition of TA = 25°C.
2. tRC is read cycle time.

**DATA RETENTION TIMING DIAGRAM 1**

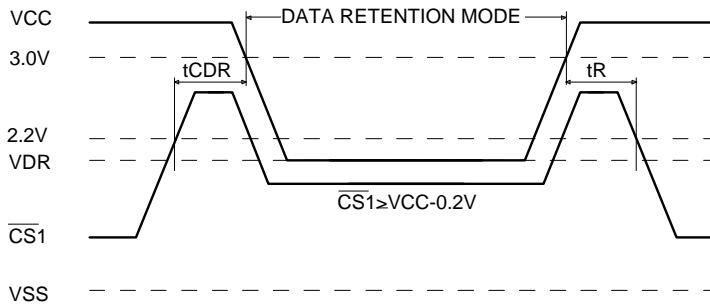

**DATA RETENTION TIMING DIAGRAM 2**

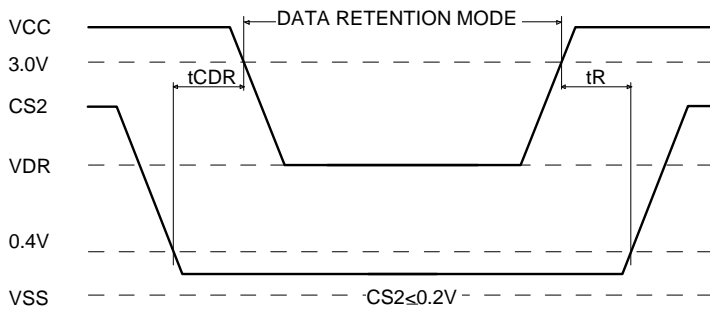



**PACKAGE INFORMATION**

32pin 525mil Small Outline Package(G)

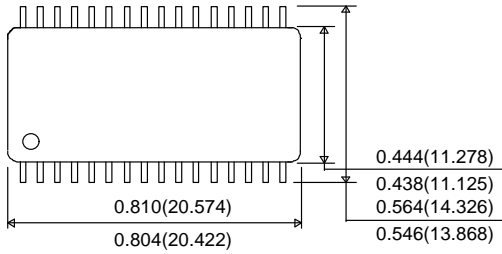

UNIT : INCH(mm)

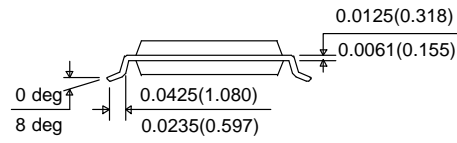
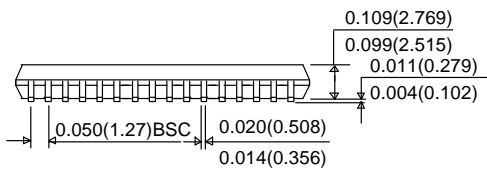

32pin 8x20mm Thin Small Outline Package Standard(T1)

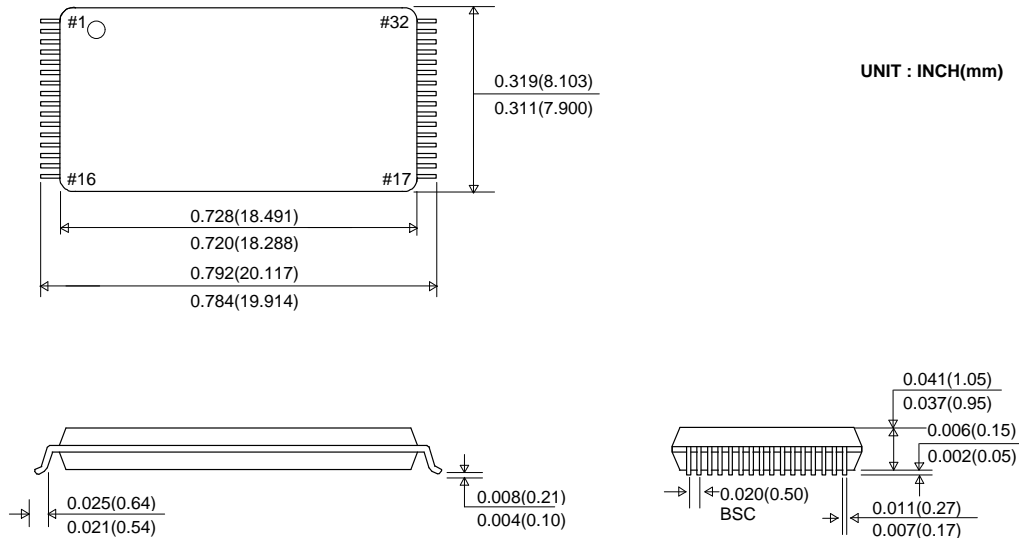

32pin 8x20mm Thin Small Outline Package Reversed(R1)

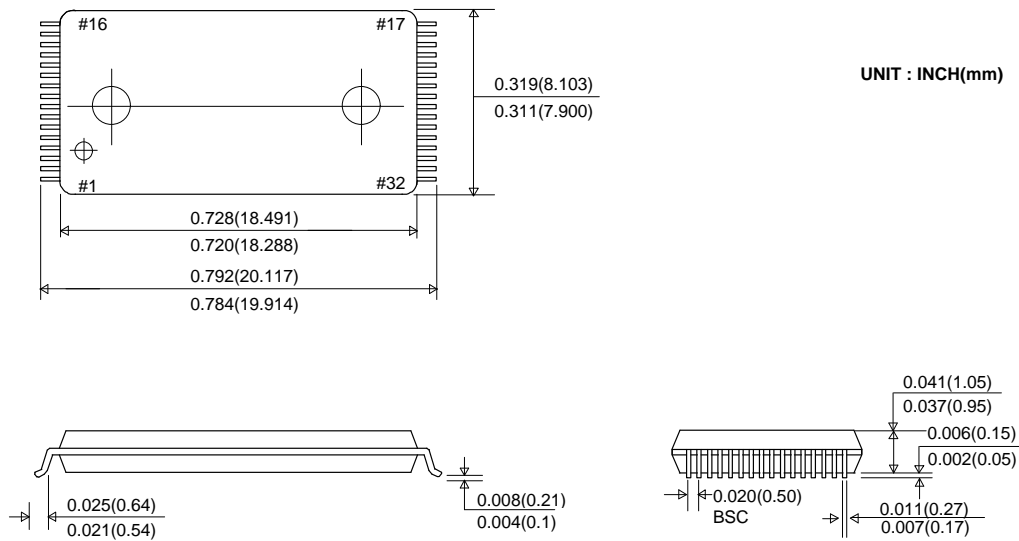

32pin 8x13.4mm Samller Thin Small Outline Package Standard(ST)

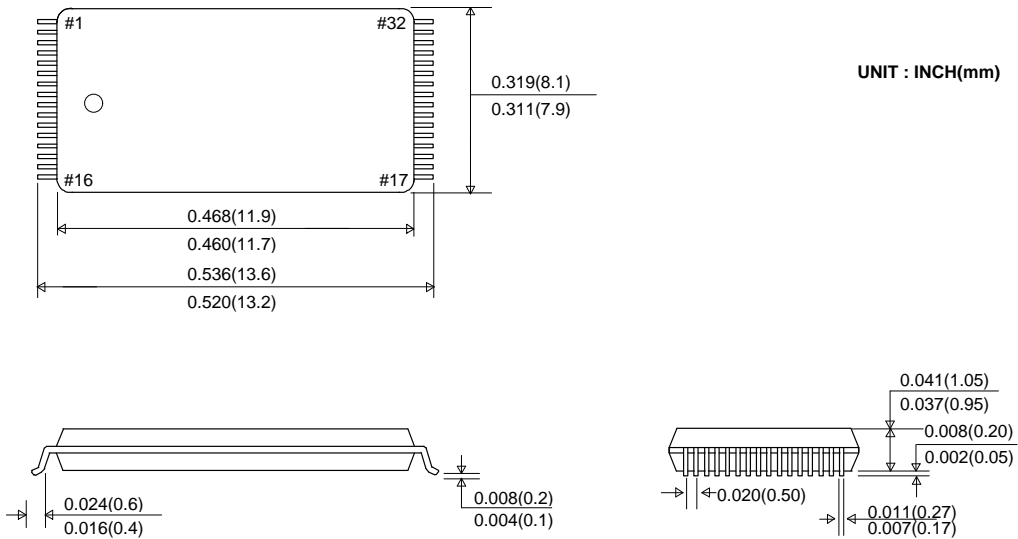

32pin 8x13.4mm Smaller Thin Small Outline Package Reversed(SR)

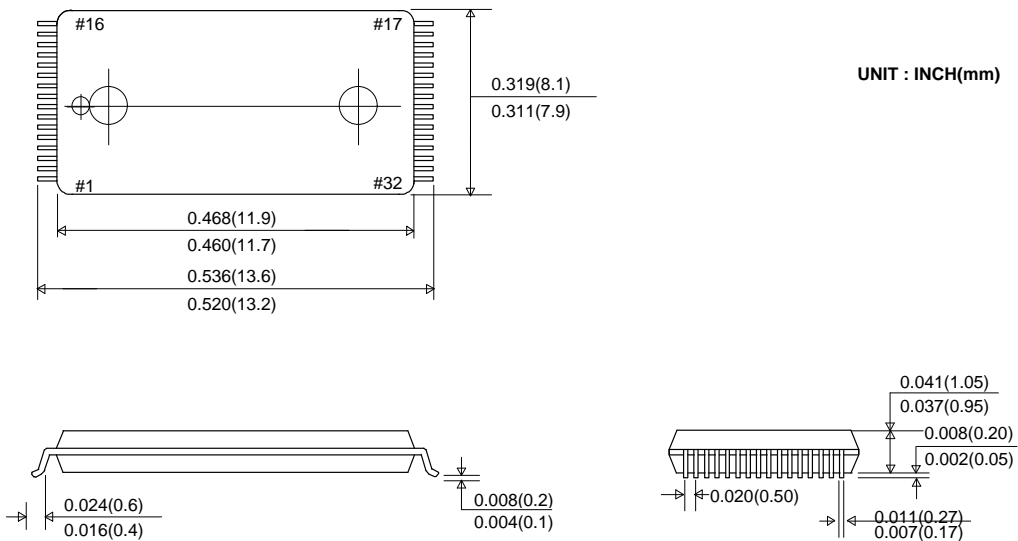

**MARKING INFORMATION**

Package	Marking Example																																																																																																																																															
SOP	<div style="border: 1px solid black; padding: 5px; margin-bottom: 5px;"> <table style="width: 100%; border-collapse: collapse;"> <tr> <td style="border: 1px solid black; text-align: center;">h</td><td style="border: 1px solid black; text-align: center;">y</td><td style="border: 1px solid black; text-align: center;">n</td><td style="border: 1px solid black; text-align: center;">i</td><td style="border: 1px solid black; text-align: center;">x</td><td style="border: 1px solid black; text-align: center;"> </td><td style="border: 1px solid black; text-align: center;"> </td><td style="border: 1px solid black; text-align: center;"> </td><td style="border: 1px solid black; text-align: center;"> </td><td style="border: 1px solid black; text-align: center;"> </td><td style="border: 1px solid black; text-align: center;"> </td><td style="border: 1px solid black; text-align: center;"> </td><td style="border: 1px solid black; text-align: center;">K</td><td style="border: 1px solid black; text-align: center;">O</td><td style="border: 1px solid black; text-align: center;">R</td><td style="border: 1px solid black; text-align: center;">E</td><td style="border: 1px solid black; text-align: center;">A</td> </tr> <tr> <td style="border: 1px solid black; text-align: center;">H</td><td style="border: 1px solid black; text-align: center;">Y</td><td style="border: 1px solid black; text-align: center;">6</td><td style="border: 1px solid black; text-align: center;">2</td><td style="border: 1px solid black; text-align: center;">V</td><td style="border: 1px solid black; text-align: center;">8</td><td style="border: 1px solid black; text-align: center;">1</td><td style="border: 1px solid black; text-align: center;">0</td><td style="border: 1px solid black; text-align: center;">0</td><td style="border: 1px solid black; text-align: center;">B</td><td style="border: 1px solid black; text-align: center;"> </td><td style="border: 1px solid black; text-align: center;"> </td><td style="border: 1px solid black; text-align: center;"> </td><td style="border: 1px solid black; text-align: center;"> </td><td style="border: 1px solid black; text-align: center;"> </td><td style="border: 1px solid black; text-align: center;"> </td><td style="border: 1px solid black; text-align: center;"> </td> </tr> <tr> <td style="border: 1px solid black; text-align: center;">y</td><td style="border: 1px solid black; text-align: center;">y</td><td style="border: 1px solid black; text-align: center;">w</td><td style="border: 1px solid black; text-align: center;">w</td><td style="border: 1px solid black; text-align: center;">p</td><td style="border: 1px solid black; text-align: center;"> </td><td style="border: 1px solid black; text-align: center;"> </td><td style="border: 1px solid black; text-align: center;"> </td><td style="border: 1px solid black; text-align: center;"> </td><td style="border: 1px solid black; text-align: center;"> </td><td style="border: 1px solid black; text-align: center;"> </td><td style="border: 1px solid black; text-align: center;"> </td><td style="border: 1px solid black; text-align: center;">c</td><td style="border: 1px solid black; text-align: center;">c</td><td style="border: 1px solid black; text-align: center;">G</td><td style="border: 1px solid black; text-align: center;">-</td><td style="border: 1px solid black; text-align: center;">s</td><td style="border: 1px solid black; text-align: center;">s</td><td style="border: 1px solid black; text-align: center;">t</td> </tr> </table> </div> <tr> <td style="text-align: center; vertical-align: middle;">TSOP-I</td> <td> <div style="border: 1px solid black; padding: 5px; margin-bottom: 5px;"> <table style="width: 100%; border-collapse: collapse;"> <tr> <td style="border: 1px solid black; text-align: center;">h</td><td style="border: 1px solid black; text-align: center;">y</td><td style="border: 1px solid black; text-align: center;">n</td><td style="border: 1px solid black; text-align: center;">i</td><td style="border: 1px solid black; text-align: center;">x</td><td style="border: 1px solid black; text-align: center;"> </td><td style="border: 1px solid black; text-align: center;"> </td><td style="border: 1px solid black; text-align: center;"> </td><td style="border: 1px solid black; text-align: center;"> </td><td style="border: 1px solid black; text-align: center;"> </td><td style="border: 1px solid black; text-align: center;"> </td><td style="border: 1px solid black; text-align: center;"> </td><td style="border: 1px solid black; text-align: center;">K</td><td style="border: 1px solid black; text-align: center;">O</td><td style="border: 1px solid black; text-align: center;">R</td><td style="border: 1px solid black; text-align: center;">E</td><td style="border: 1px solid black; text-align: center;">A</td> </tr> <tr> <td style="border: 1px solid black; text-align: center;">H</td><td style="border: 1px solid black; text-align: center;">Y</td><td style="border: 1px solid black; text-align: center;">6</td><td style="border: 1px solid black; text-align: center;">2</td><td style="border: 1px solid black; text-align: center;">V</td><td style="border: 1px solid black; text-align: center;">8</td><td style="border: 1px solid black; text-align: center;">1</td><td style="border: 1px solid black; text-align: center;">0</td><td style="border: 1px solid black; text-align: center;">0</td><td style="border: 1px solid black; text-align: center;">B</td><td style="border: 1px solid black; text-align: center;"> </td><td style="border: 1px solid black; text-align: center;"> </td><td style="border: 1px solid black; text-align: center;"> </td><td style="border: 1px solid black; text-align: center;"> </td><td style="border: 1px solid black; text-align: center;"> </td><td style="border: 1px solid black; text-align: center;"> </td><td style="border: 1px solid black; text-align: center;"> </td><td style="border: 1px solid black; text-align: center;"> </td><td style="border: 1px solid black; text-align: center;"> </td> </tr> <tr> <td style="border: 1px solid black; text-align: center;">y</td><td style="border: 1px solid black; text-align: center;">y</td><td style="border: 1px solid black; text-align: center;">w</td><td style="border: 1px solid black; text-align: center;">w</td><td style="border: 1px solid black; text-align: center;">p</td><td style="border: 1px solid black; text-align: center;"> </td><td style="border: 1px solid black; text-align: center;"> </td><td style="border: 1px solid black; text-align: center;"> </td><td style="border: 1px solid black; text-align: center;"> </td><td style="border: 1px solid black; text-align: center;"> </td><td style="border: 1px solid black; text-align: center;"> </td><td style="border: 1px solid black; text-align: center;"> </td><td style="border: 1px solid black; text-align: center;">c</td><td style="border: 1px solid black; text-align: center;">c</td><td style="border: 1px solid black; text-align: center;">T</td><td style="border: 1px solid black; text-align: center;">1</td><td style="border: 1px solid black; text-align: center;">-</td><td style="border: 1px solid black; text-align: center;">s</td><td style="border: 1px solid black; text-align: center;">s</td><td style="border: 1px solid black; text-align: center;">t</td> </tr> </table> </div> <tr> <td style="text-align: center; vertical-align: middle;">sTSOP</td> <td> <div style="border: 1px solid black; padding: 5px;"> <table style="width: 100%; border-collapse: collapse;"> <tr> <td style="border: 1px solid black; text-align: center;">H</td><td style="border: 1px solid black; text-align: center;">Y</td><td style="border: 1px solid black; text-align: center;">6</td><td style="border: 1px solid black; text-align: center;">2</td><td style="border: 1px solid black; text-align: center;">V</td><td style="border: 1px solid black; text-align: center;">8</td><td style="border: 1px solid black; text-align: center;">1</td><td style="border: 1px solid black; text-align: center;">0</td><td style="border: 1px solid black; text-align: center;">0</td><td style="border: 1px solid black; text-align: center;">B</td> </tr> <tr> <td style="border: 1px solid black; text-align: center;">c</td><td style="border: 1px solid black; text-align: center;">c</td><td style="border: 1px solid black; text-align: center;">S</td><td style="border: 1px solid black; text-align: center;">T</td><td style="border: 1px solid black; text-align: center;">-</td><td style="border: 1px solid black; text-align: center;">s</td><td style="border: 1px solid black; text-align: center;">s</td><td style="border: 1px solid black; text-align: center;">t</td><td style="border: 1px solid black; text-align: center;"> </td><td style="border: 1px solid black; text-align: center;"> </td> </tr> <tr> <td style="border: 1px solid black; text-align: center;">y</td><td style="border: 1px solid black; text-align: center;">y</td><td style="border: 1px solid black; text-align: center;">w</td><td style="border: 1px solid black; text-align: center;">w</td><td style="border: 1px solid black; text-align: center;">p</td><td style="border: 1px solid black; text-align: center;"> </td><td style="border: 1px solid black; text-align: center;"> </td><td style="border: 1px solid black; text-align: center;"> </td><td style="border: 1px solid black; text-align: center;"> </td><td style="border: 1px solid black; text-align: center;"> </td> </tr> </table> </div> </td> </tr> </td></tr>	h	y	n	i	x								K	O	R	E	A	H	Y	6	2	V	8	1	0	0	B								y	y	w	w	p								c	c	G	-	s	s	t	TSOP-I	<div style="border: 1px solid black; padding: 5px; margin-bottom: 5px;"> <table style="width: 100%; border-collapse: collapse;"> <tr> <td style="border: 1px solid black; text-align: center;">h</td><td style="border: 1px solid black; text-align: center;">y</td><td style="border: 1px solid black; text-align: center;">n</td><td style="border: 1px solid black; text-align: center;">i</td><td style="border: 1px solid black; text-align: center;">x</td><td style="border: 1px solid black; text-align: center;"> </td><td style="border: 1px solid black; text-align: center;"> </td><td style="border: 1px solid black; text-align: center;"> </td><td style="border: 1px solid black; text-align: center;"> </td><td style="border: 1px solid black; text-align: center;"> </td><td style="border: 1px solid black; text-align: center;"> </td><td style="border: 1px solid black; text-align: center;"> </td><td style="border: 1px solid black; text-align: center;">K</td><td style="border: 1px solid black; text-align: center;">O</td><td style="border: 1px solid black; text-align: center;">R</td><td style="border: 1px solid black; text-align: center;">E</td><td style="border: 1px solid black; text-align: center;">A</td> </tr> <tr> <td style="border: 1px solid black; text-align: center;">H</td><td style="border: 1px solid black; text-align: center;">Y</td><td style="border: 1px solid black; text-align: center;">6</td><td style="border: 1px solid black; text-align: center;">2</td><td style="border: 1px solid black; text-align: center;">V</td><td style="border: 1px solid black; text-align: center;">8</td><td style="border: 1px solid black; text-align: center;">1</td><td style="border: 1px solid black; text-align: center;">0</td><td style="border: 1px solid black; text-align: center;">0</td><td style="border: 1px solid black; text-align: center;">B</td><td style="border: 1px solid black; text-align: center;"> </td><td style="border: 1px solid black; text-align: center;"> </td><td style="border: 1px solid black; text-align: center;"> </td><td style="border: 1px solid black; text-align: center;"> </td><td style="border: 1px solid black; text-align: center;"> </td><td style="border: 1px solid black; text-align: center;"> </td><td style="border: 1px solid black; text-align: center;"> </td><td style="border: 1px solid black; text-align: center;"> </td><td style="border: 1px solid black; text-align: center;"> </td> </tr> <tr> <td style="border: 1px solid black; text-align: center;">y</td><td style="border: 1px solid black; text-align: center;">y</td><td style="border: 1px solid black; text-align: center;">w</td><td style="border: 1px solid black; text-align: center;">w</td><td style="border: 1px solid black; text-align: center;">p</td><td style="border: 1px solid black; text-align: center;"> </td><td style="border: 1px solid black; text-align: center;"> </td><td style="border: 1px solid black; text-align: center;"> </td><td style="border: 1px solid black; text-align: center;"> </td><td style="border: 1px solid black; text-align: center;"> </td><td style="border: 1px solid black; text-align: center;"> </td><td style="border: 1px solid black; text-align: center;"> </td><td style="border: 1px solid black; text-align: center;">c</td><td style="border: 1px solid black; text-align: center;">c</td><td style="border: 1px solid black; text-align: center;">T</td><td style="border: 1px solid black; text-align: center;">1</td><td style="border: 1px solid black; text-align: center;">-</td><td style="border: 1px solid black; text-align: center;">s</td><td style="border: 1px solid black; text-align: center;">s</td><td style="border: 1px solid black; text-align: center;">t</td> </tr> </table> </div> <tr> <td style="text-align: center; vertical-align: middle;">sTSOP</td> <td> <div style="border: 1px solid black; padding: 5px;"> <table style="width: 100%; border-collapse: collapse;"> <tr> <td style="border: 1px solid black; text-align: center;">H</td><td style="border: 1px solid black; text-align: center;">Y</td><td style="border: 1px solid black; text-align: center;">6</td><td style="border: 1px solid black; text-align: center;">2</td><td style="border: 1px solid black; text-align: center;">V</td><td style="border: 1px solid black; text-align: center;">8</td><td style="border: 1px solid black; text-align: center;">1</td><td style="border: 1px solid black; text-align: center;">0</td><td style="border: 1px solid black; text-align: center;">0</td><td style="border: 1px solid black; text-align: center;">B</td> </tr> <tr> <td style="border: 1px solid black; text-align: center;">c</td><td style="border: 1px solid black; text-align: center;">c</td><td style="border: 1px solid black; text-align: center;">S</td><td style="border: 1px solid black; text-align: center;">T</td><td style="border: 1px solid black; text-align: center;">-</td><td style="border: 1px solid black; text-align: center;">s</td><td style="border: 1px solid black; text-align: center;">s</td><td style="border: 1px solid black; text-align: center;">t</td><td style="border: 1px solid black; text-align: center;"> </td><td style="border: 1px solid black; text-align: center;"> </td> </tr> <tr> <td style="border: 1px solid black; text-align: center;">y</td><td style="border: 1px solid black; text-align: center;">y</td><td style="border: 1px solid black; text-align: center;">w</td><td style="border: 1px solid black; text-align: center;">w</td><td style="border: 1px solid black; text-align: center;">p</td><td style="border: 1px solid black; text-align: center;"> </td><td style="border: 1px solid black; text-align: center;"> </td><td style="border: 1px solid black; text-align: center;"> </td><td style="border: 1px solid black; text-align: center;"> </td><td style="border: 1px solid black; text-align: center;"> </td> </tr> </table> </div> </td> </tr>	h	y	n	i	x								K	O	R	E	A	H	Y	6	2	V	8	1	0	0	B										y	y	w	w	p								c	c	T	1	-	s	s	t	sTSOP	<div style="border: 1px solid black; padding: 5px;"> <table style="width: 100%; border-collapse: collapse;"> <tr> <td style="border: 1px solid black; text-align: center;">H</td><td style="border: 1px solid black; text-align: center;">Y</td><td style="border: 1px solid black; text-align: center;">6</td><td style="border: 1px solid black; text-align: center;">2</td><td style="border: 1px solid black; text-align: center;">V</td><td style="border: 1px solid black; text-align: center;">8</td><td style="border: 1px solid black; text-align: center;">1</td><td style="border: 1px solid black; text-align: center;">0</td><td style="border: 1px solid black; text-align: center;">0</td><td style="border: 1px solid black; text-align: center;">B</td> </tr> <tr> <td style="border: 1px solid black; text-align: center;">c</td><td style="border: 1px solid black; text-align: center;">c</td><td style="border: 1px solid black; text-align: center;">S</td><td style="border: 1px solid black; text-align: center;">T</td><td style="border: 1px solid black; text-align: center;">-</td><td style="border: 1px solid black; text-align: center;">s</td><td style="border: 1px solid black; text-align: center;">s</td><td style="border: 1px solid black; text-align: center;">t</td><td style="border: 1px solid black; text-align: center;"> </td><td style="border: 1px solid black; text-align: center;"> </td> </tr> <tr> <td style="border: 1px solid black; text-align: center;">y</td><td style="border: 1px solid black; text-align: center;">y</td><td style="border: 1px solid black; text-align: center;">w</td><td style="border: 1px solid black; text-align: center;">w</td><td style="border: 1px solid black; text-align: center;">p</td><td style="border: 1px solid black; text-align: center;"> </td><td style="border: 1px solid black; text-align: center;"> </td><td style="border: 1px solid black; text-align: center;"> </td><td style="border: 1px solid black; text-align: center;"> </td><td style="border: 1px solid black; text-align: center;"> </td> </tr> </table> </div>	H	Y	6	2	V	8	1	0	0	B	c	c	S	T	-	s	s	t			y	y	w	w	p					
h	y	n	i	x								K	O	R	E	A																																																																																																																																
H	Y	6	2	V	8	1	0	0	B																																																																																																																																							
y	y	w	w	p								c	c	G	-	s	s	t																																																																																																																														
TSOP-I	<div style="border: 1px solid black; padding: 5px; margin-bottom: 5px;"> <table style="width: 100%; border-collapse: collapse;"> <tr> <td style="border: 1px solid black; text-align: center;">h</td><td style="border: 1px solid black; text-align: center;">y</td><td style="border: 1px solid black; text-align: center;">n</td><td style="border: 1px solid black; text-align: center;">i</td><td style="border: 1px solid black; text-align: center;">x</td><td style="border: 1px solid black; text-align: center;"> </td><td style="border: 1px solid black; text-align: center;"> </td><td style="border: 1px solid black; text-align: center;"> </td><td style="border: 1px solid black; text-align: center;"> </td><td style="border: 1px solid black; text-align: center;"> </td><td style="border: 1px solid black; text-align: center;"> </td><td style="border: 1px solid black; text-align: center;"> </td><td style="border: 1px solid black; text-align: center;">K</td><td style="border: 1px solid black; text-align: center;">O</td><td style="border: 1px solid black; text-align: center;">R</td><td style="border: 1px solid black; text-align: center;">E</td><td style="border: 1px solid black; text-align: center;">A</td> </tr> <tr> <td style="border: 1px solid black; text-align: center;">H</td><td style="border: 1px solid black; text-align: center;">Y</td><td style="border: 1px solid black; text-align: center;">6</td><td style="border: 1px solid black; text-align: center;">2</td><td style="border: 1px solid black; text-align: center;">V</td><td style="border: 1px solid black; text-align: center;">8</td><td style="border: 1px solid black; text-align: center;">1</td><td style="border: 1px solid black; text-align: center;">0</td><td style="border: 1px solid black; text-align: center;">0</td><td style="border: 1px solid black; text-align: center;">B</td><td style="border: 1px solid black; text-align: center;"> </td><td style="border: 1px solid black; text-align: center;"> </td><td style="border: 1px solid black; text-align: center;"> </td><td style="border: 1px solid black; text-align: center;"> </td><td style="border: 1px solid black; text-align: center;"> </td><td style="border: 1px solid black; text-align: center;"> </td><td style="border: 1px solid black; text-align: center;"> </td><td style="border: 1px solid black; text-align: center;"> </td><td style="border: 1px solid black; text-align: center;"> </td> </tr> <tr> <td style="border: 1px solid black; text-align: center;">y</td><td style="border: 1px solid black; text-align: center;">y</td><td style="border: 1px solid black; text-align: center;">w</td><td style="border: 1px solid black; text-align: center;">w</td><td style="border: 1px solid black; text-align: center;">p</td><td style="border: 1px solid black; text-align: center;"> </td><td style="border: 1px solid black; text-align: center;"> </td><td style="border: 1px solid black; text-align: center;"> </td><td style="border: 1px solid black; text-align: center;"> </td><td style="border: 1px solid black; text-align: center;"> </td><td style="border: 1px solid black; text-align: center;"> </td><td style="border: 1px solid black; text-align: center;"> </td><td style="border: 1px solid black; text-align: center;">c</td><td style="border: 1px solid black; text-align: center;">c</td><td style="border: 1px solid black; text-align: center;">T</td><td style="border: 1px solid black; text-align: center;">1</td><td style="border: 1px solid black; text-align: center;">-</td><td style="border: 1px solid black; text-align: center;">s</td><td style="border: 1px solid black; text-align: center;">s</td><td style="border: 1px solid black; text-align: center;">t</td> </tr> </table> </div> <tr> <td style="text-align: center; vertical-align: middle;">sTSOP</td> <td> <div style="border: 1px solid black; padding: 5px;"> <table style="width: 100%; border-collapse: collapse;"> <tr> <td style="border: 1px solid black; text-align: center;">H</td><td style="border: 1px solid black; text-align: center;">Y</td><td style="border: 1px solid black; text-align: center;">6</td><td style="border: 1px solid black; text-align: center;">2</td><td style="border: 1px solid black; text-align: center;">V</td><td style="border: 1px solid black; text-align: center;">8</td><td style="border: 1px solid black; text-align: center;">1</td><td style="border: 1px solid black; text-align: center;">0</td><td style="border: 1px solid black; text-align: center;">0</td><td style="border: 1px solid black; text-align: center;">B</td> </tr> <tr> <td style="border: 1px solid black; text-align: center;">c</td><td style="border: 1px solid black; text-align: center;">c</td><td style="border: 1px solid black; text-align: center;">S</td><td style="border: 1px solid black; text-align: center;">T</td><td style="border: 1px solid black; text-align: center;">-</td><td style="border: 1px solid black; text-align: center;">s</td><td style="border: 1px solid black; text-align: center;">s</td><td style="border: 1px solid black; text-align: center;">t</td><td style="border: 1px solid black; text-align: center;"> </td><td style="border: 1px solid black; text-align: center;"> </td> </tr> <tr> <td style="border: 1px solid black; text-align: center;">y</td><td style="border: 1px solid black; text-align: center;">y</td><td style="border: 1px solid black; text-align: center;">w</td><td style="border: 1px solid black; text-align: center;">w</td><td style="border: 1px solid black; text-align: center;">p</td><td style="border: 1px solid black; text-align: center;"> </td><td style="border: 1px solid black; text-align: center;"> </td><td style="border: 1px solid black; text-align: center;"> </td><td style="border: 1px solid black; text-align: center;"> </td><td style="border: 1px solid black; text-align: center;"> </td> </tr> </table> </div> </td> </tr>	h	y	n	i	x								K	O	R	E	A	H	Y	6	2	V	8	1	0	0	B										y	y	w	w	p								c	c	T	1	-	s	s	t	sTSOP	<div style="border: 1px solid black; padding: 5px;"> <table style="width: 100%; border-collapse: collapse;"> <tr> <td style="border: 1px solid black; text-align: center;">H</td><td style="border: 1px solid black; text-align: center;">Y</td><td style="border: 1px solid black; text-align: center;">6</td><td style="border: 1px solid black; text-align: center;">2</td><td style="border: 1px solid black; text-align: center;">V</td><td style="border: 1px solid black; text-align: center;">8</td><td style="border: 1px solid black; text-align: center;">1</td><td style="border: 1px solid black; text-align: center;">0</td><td style="border: 1px solid black; text-align: center;">0</td><td style="border: 1px solid black; text-align: center;">B</td> </tr> <tr> <td style="border: 1px solid black; text-align: center;">c</td><td style="border: 1px solid black; text-align: center;">c</td><td style="border: 1px solid black; text-align: center;">S</td><td style="border: 1px solid black; text-align: center;">T</td><td style="border: 1px solid black; text-align: center;">-</td><td style="border: 1px solid black; text-align: center;">s</td><td style="border: 1px solid black; text-align: center;">s</td><td style="border: 1px solid black; text-align: center;">t</td><td style="border: 1px solid black; text-align: center;"> </td><td style="border: 1px solid black; text-align: center;"> </td> </tr> <tr> <td style="border: 1px solid black; text-align: center;">y</td><td style="border: 1px solid black; text-align: center;">y</td><td style="border: 1px solid black; text-align: center;">w</td><td style="border: 1px solid black; text-align: center;">w</td><td style="border: 1px solid black; text-align: center;">p</td><td style="border: 1px solid black; text-align: center;"> </td><td style="border: 1px solid black; text-align: center;"> </td><td style="border: 1px solid black; text-align: center;"> </td><td style="border: 1px solid black; text-align: center;"> </td><td style="border: 1px solid black; text-align: center;"> </td> </tr> </table> </div>	H	Y	6	2	V	8	1	0	0	B	c	c	S	T	-	s	s	t			y	y	w	w	p																																																												
h	y	n	i	x								K	O	R	E	A																																																																																																																																
H	Y	6	2	V	8	1	0	0	B																																																																																																																																							
y	y	w	w	p								c	c	T	1	-	s	s	t																																																																																																																													
sTSOP	<div style="border: 1px solid black; padding: 5px;"> <table style="width: 100%; border-collapse: collapse;"> <tr> <td style="border: 1px solid black; text-align: center;">H</td><td style="border: 1px solid black; text-align: center;">Y</td><td style="border: 1px solid black; text-align: center;">6</td><td style="border: 1px solid black; text-align: center;">2</td><td style="border: 1px solid black; text-align: center;">V</td><td style="border: 1px solid black; text-align: center;">8</td><td style="border: 1px solid black; text-align: center;">1</td><td style="border: 1px solid black; text-align: center;">0</td><td style="border: 1px solid black; text-align: center;">0</td><td style="border: 1px solid black; text-align: center;">B</td> </tr> <tr> <td style="border: 1px solid black; text-align: center;">c</td><td style="border: 1px solid black; text-align: center;">c</td><td style="border: 1px solid black; text-align: center;">S</td><td style="border: 1px solid black; text-align: center;">T</td><td style="border: 1px solid black; text-align: center;">-</td><td style="border: 1px solid black; text-align: center;">s</td><td style="border: 1px solid black; text-align: center;">s</td><td style="border: 1px solid black; text-align: center;">t</td><td style="border: 1px solid black; text-align: center;"> </td><td style="border: 1px solid black; text-align: center;"> </td> </tr> <tr> <td style="border: 1px solid black; text-align: center;">y</td><td style="border: 1px solid black; text-align: center;">y</td><td style="border: 1px solid black; text-align: center;">w</td><td style="border: 1px solid black; text-align: center;">w</td><td style="border: 1px solid black; text-align: center;">p</td><td style="border: 1px solid black; text-align: center;"> </td><td style="border: 1px solid black; text-align: center;"> </td><td style="border: 1px solid black; text-align: center;"> </td><td style="border: 1px solid black; text-align: center;"> </td><td style="border: 1px solid black; text-align: center;"> </td> </tr> </table> </div>	H	Y	6	2	V	8	1	0	0	B	c	c	S	T	-	s	s	t			y	y	w	w	p																																																																																																																						
H	Y	6	2	V	8	1	0	0	B																																																																																																																																							
c	c	S	T	-	s	s	t																																																																																																																																									
y	y	w	w	p																																																																																																																																												

Index	
• hynix	: hynix Logo
• KOREA / KOR	: Origin Country
• HY62V8100B	: Part Name
• yy	: Year ( ex : 00 = year 2000, 01 = year 2001 )
• ww	: Work Week ( ex : 12 = ww12 )
• p	: Process Code
• cc	: Power Consumption
	- L : Low Power
	- LL : Low Low Power
• G / T1 / ST	: Package Type
	- G : SOP
	- T1 : TSOP-I
	- ST : sTSOP
• ss	: Speed
	- 70 : 70ns
	- 85 : 85ns
• t	: Temperature
	- Blank : Commercial ( 0 ~ 70 °C )
	- E : Extended ( -25 ~ 85 °C )
	- I : Industrial ( -40 ~ 85 °C )
<b>Note</b>	
- Capital Letter	: Fixed Item
- Small Letter	: Non-fixed Item (Except hynix)