

SINGLE COMPARATOR

- Be Possible to Operate at the Wide Range Single or Two Supply Voltage. : 2~36V, 1~±18V
- Low Supply Current. : $I_{CC}=0.4mA(Typ.)$.
- Low Input Offset Voltage : $V_{IO}=2mV(Typ.)$.
- Wide Common Mode Input Voltage : $0V_{DC}$ to $V_{CC}-1.5V_{DC}$.
- Output is Compatible with TTL, DTL, MOS and C-MOS.
- Output is Open Collector and Wired-OR Possible.

PIN CONNECTION (TOP VIEW)

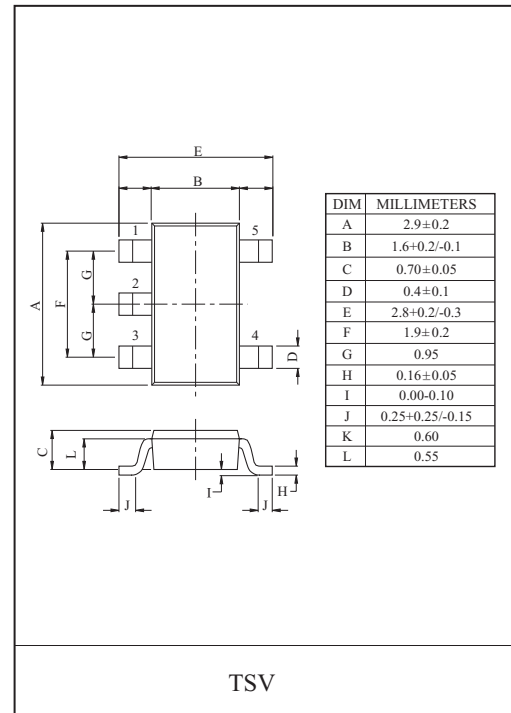
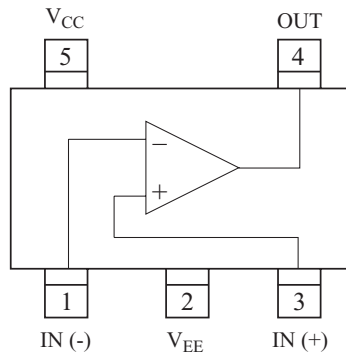

Marking (TOP VIEW)

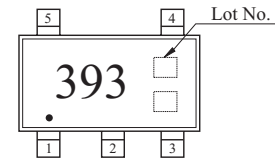

MAXIMUM RATINGS (Ta=25 °C)

CHARACTERISTIC	SYMBOL	RATING	UNIT
Supply Voltage	V_{CC}	±18, 36	V
Differential Input Voltage	DV_{IN}	±18, 36	V
Common Mode Input Voltage	CMV_{IN}	-0.3 ~ V_{CC}	V
Power Dissipation	P_D	200	mW
Operating Temperature	T_{opr}	-40 ~ 85	°C
Storage Temperature	T_{stg}	-55 ~ 125	°C

KIA75S393F

EQUIVALENT CIRCUIT

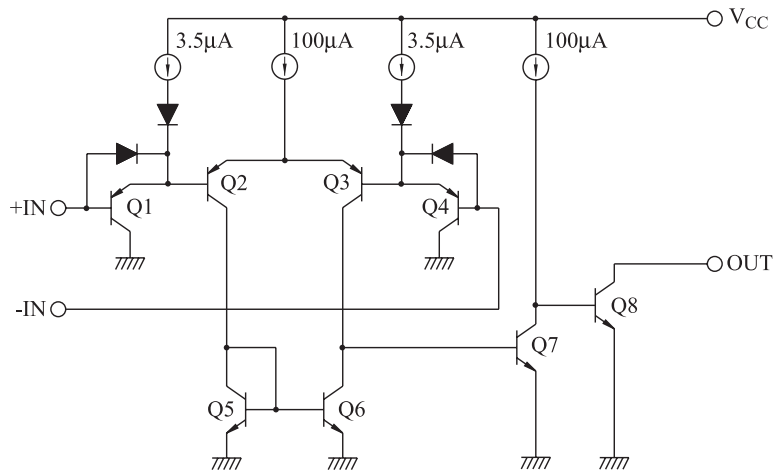

ELECTRICAL CHARACTERISTICS ($V_{CC}=5V$, $V_{EE}=GND$, $T_a=25^\circ C$)

CHARACTERISTIC	SYMBOL	TEST CONDITION	MIN.	TYP.	MAX.	UNIT
Input Offset Voltage	V_{IO}	$V_O=1.4V$	-	2	5	mV
Input Offset Current	I_{IO}	-	-	5	50	nA
Input Bias Current	I_I	-	-	25	250	nA
Common Mode Input Voltage	CMV_{IN}	-	0	-	$V_{CC}-1.5$	V
Voltage Gain	G_V	$R_L=15k\ \Omega$	-	200	-	V/mV
Supply Current	I_{CC}	No load	-	0.4	0.8	mA
Sink Current	I_{sink}	+IN=0V, -IN=1V, $V_{OL}=1.5V$	6	16	-	mA
Output Voltage ("L" Level)	V_{OL}	+IN=0V, -IN=1V, $I_{sink}=3mA$	-	0.2	0.4	V
Output Leak Current	I_{LEAK}	+IN=1V, -IN=0V, $V_O=5V$	-	0.1	-	nA
Response Time	t_{rsp}	$R_L=5.1k\ \Omega$, $C_L=15pF$	-	1.3	-	μs

KIA75S393F

