

### 5 TERMINAL LOW DROPOUT VOLTAGE REGULATOR

The KIA78R × × series are Low Dropout Voltage Regulator suitable for various electronic equipments. It provides constant voltage power source with TO-220IS-4 terminal surface mount type PKG.

The Regulator has multi function such as over current protection, overheat protection and ON/OFF control.

#### FEATURES

- 1.0A Output Low Dropout Voltage Regulator.
- Built in ON/OFF Control Terminal.
- Built in Over Current Protection, Over Heat Protection Function.

#### LINE UP

ITEM	OUTPUT VOLTAGE (Typ.)	UNIT
KIA78R05PI	5	V
KIA78R06PI	6	
KIA78R08PI	8	
KIA78R09PI	9	
KIA78R10PI	10	
KIA78R12PI	12	
KIA78R15PI	15	
KIA78R25PI	2.5	
KIA78R33PI	3.3	
KIA78R35PI	3.5	

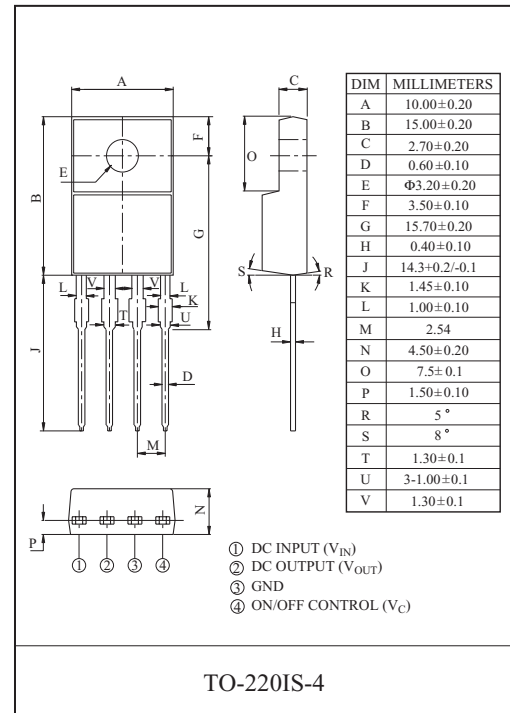

#### MAXIMUM RATINGS (Ta=25 °C)

CHARACTERISTIC	SYMBOL	RATING	UNIT	REMARK
Input Voltage	V <sub>IN</sub>	35	V	-
ON/OFF Control Voltage	V <sub>C</sub>	35	V	-
Output Current	I <sub>O</sub>	1	A	-
Power Dissipation 1	P <sub>D1</sub>	1.5	W	No Heatsink
Power Dissipation 2	P <sub>D2</sub>	15	W	Infinite Heatsink
Operating Junction Temperature	T <sub>J(opr)</sub>	-40~150	°C	-
Storage Temperature	T <sub>stg</sub>	-45~150	°C	-
Soldering Temperature (10sec)	T <sub>sol</sub>	260	°C	-

# KIA78R05PI~KIA78R35PI

## ELECTRICAL CHARACTERISTICS

(Unless otherwise specified,  $I_O=0.5A$ ,  $T_a=25^\circ C$ , Note1.)

CHARACTERISTIC		SYMBOL	CONDITIONS	MIN.	TYP.	MAX.	UNIT
Output Voltage	KIA78R05PI	$V_O$	-	4.88	5.0	5.12	V
	KIA78R06PI		-	5.85	6.0	6.15	
	KIA78R08PI		-	7.80	8.0	8.2	
	KIA78R09PI		-	8.78	9.0	9.22	
	KIA78R10PI		-	9.75	10.0	10.25	
	KIA78R12PI		-	11.70	12.0	12.30	
	KIA78R15PI		-	14.70	15.0	15.30	
	KIA78R25PI		-	2.438	2.50	2.562	
	KIA78R33PI		-	3.220	3.30	3.380	
	KIA78R35PI		-	3.413	3.50	3.587	
Load Regulation		Reg Load	$5mA \leq I_{OUT} \leq 1A$	-	0.1	2.0	%
Line Regulation		Reg Line	(Note 2)	-	0.5	2.5	%
Temperature Coefficient of Output Voltage		$T_C V_O$	$T_j=0 \sim 125^\circ C$	-	$\pm 0.02$	$\pm 0.05$	%/ $^\circ C$
Ripple Rejection		$R \cdot R$	-	45	55	-	dB
Drop Out Voltage		$V_D$	$I_O=1A, V_{IN}=0.95 V_{OUT}$	-	-	0.5	V
Output ON state for control Voltage		$V_{C(ON)}$	-	2.0	-	-	V
Output ON state for control Current		$I_{C(ON)}$	$V_C=2.7V$	-	-	20	$\mu A$
Output OFF state for control Voltage		$V_{C(OFF)}$	-	-	-	0.8	V
Output OFF state for control Current		$I_{C(OFF)}$	$V_C=0.4V$	-	-	-0.4	mA
Quiescent Current		$I_Q$	$I_O=0$	-	-	10	mA

Note1)  $V_{IN}$  of KIA78R05=7V

- " KIA78R06=8V
- " KIA78R08=10V
- " KIA78R09=15V
- " KIA78R10=16V
- " KIA78R12=18V
- " KIA78R15=21V
- " KIA78R25=4.2V
- " KIA78R33=5.0V
- " KIA78R35=5.2V

Note2)  $V_{IN}$  of KIA78R05=6~12V

- " KIA78R06=7~15V
- " KIA78R08=9~25V
- " KIA78R09=10~25V
- " KIA78R10=11~26V
- " KIA78R12=13~29V
- " KIA78R15=16~32V
- " KIA78R25=3.2~10V
- " KIA78R33=4.0~10V
- " KIA78R35=4.2~10V

# KIA78R05PI~KIA78R35PI

## BLOCK DIAGRAM

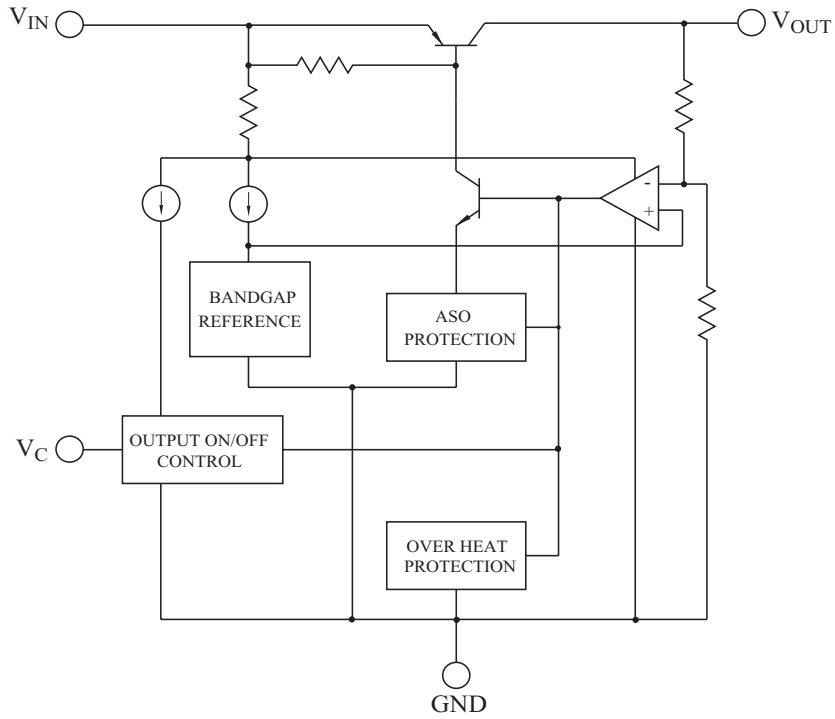

# KIA78R05PI~KIA78R35PI

**Fig. 1 Standard Test Circuit**

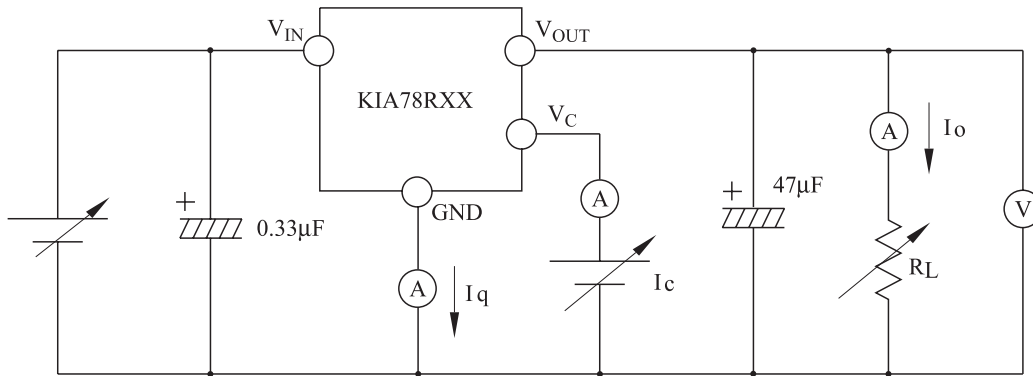

**Fig. 2 Ripple Rejection Test Circuit**

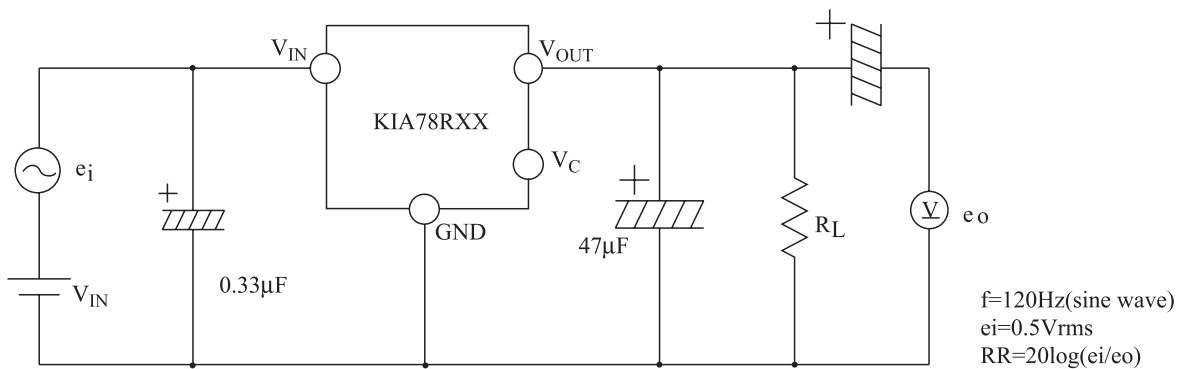

**Fig. 3 Application Circuit for Standard**

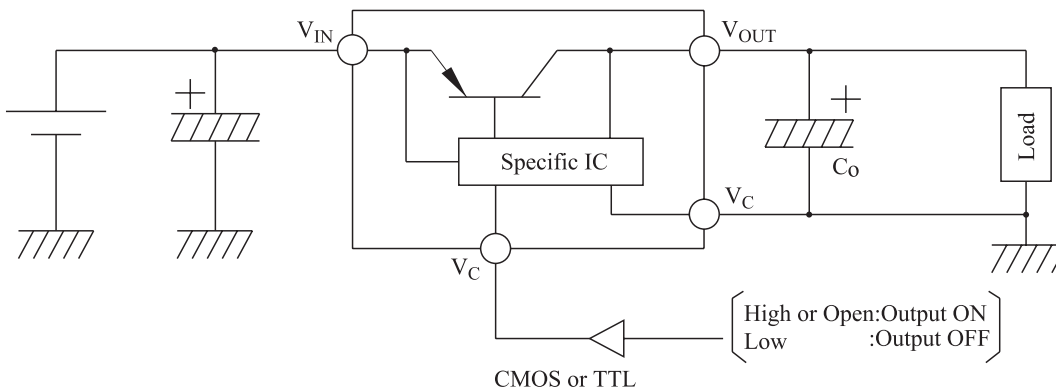

# KIA78R05PI~KIA78R35PI

Fig.4  $P_D - T_a$  (PI-Type : TO-220IS-4)

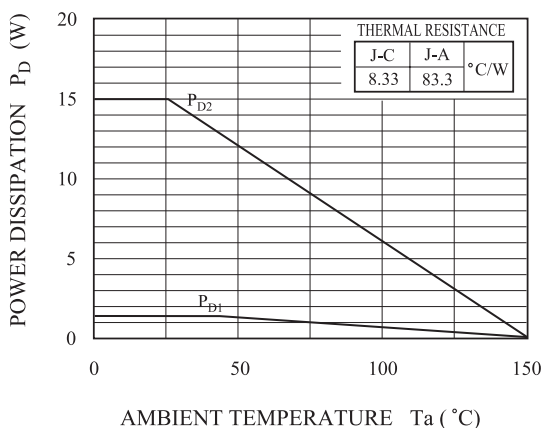

Fig. 5  $V_{OUT} - I_{OUT}$

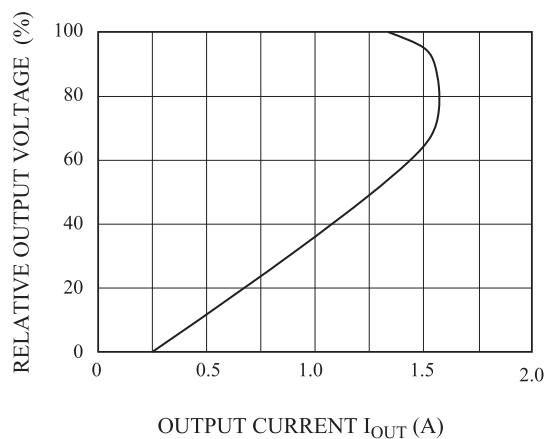

Fig. 6  $\Delta V_O - T_j$

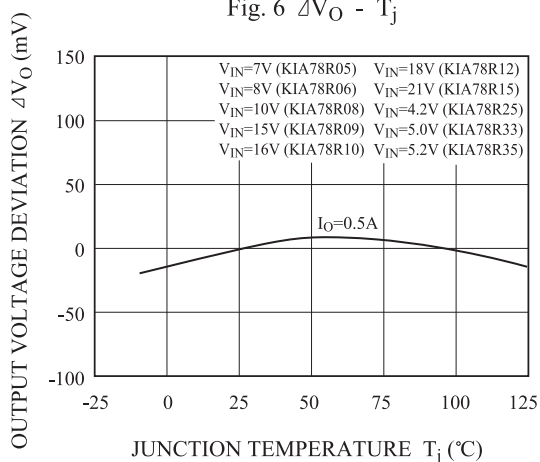

Fig. 7  $V_D - T_j$

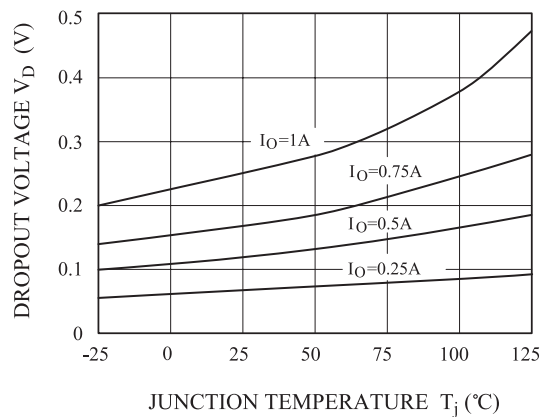

Fig. 8  $I_q - T_j$

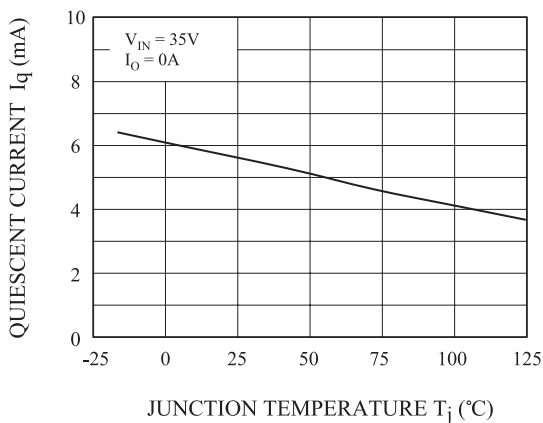
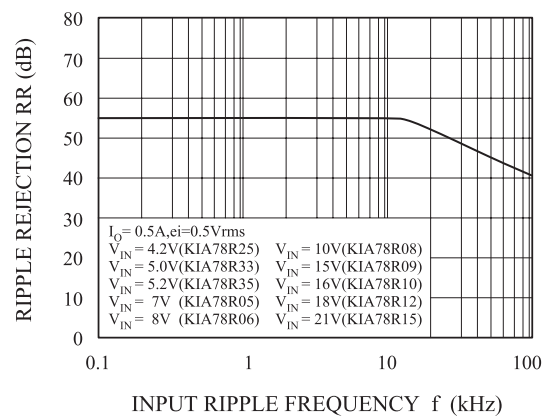

Fig. 9 R.R - f



# KIA78R05PI~KIA78R35PI

Fig. 10 R.R - I<sub>OUT</sub>

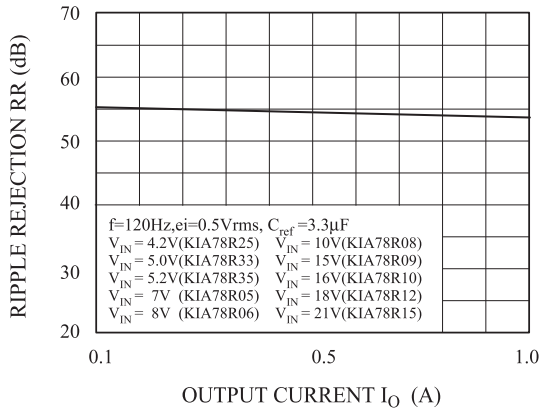

Fig. 11 V<sub>OUT</sub> - V<sub>IN</sub> (KIA78R05)

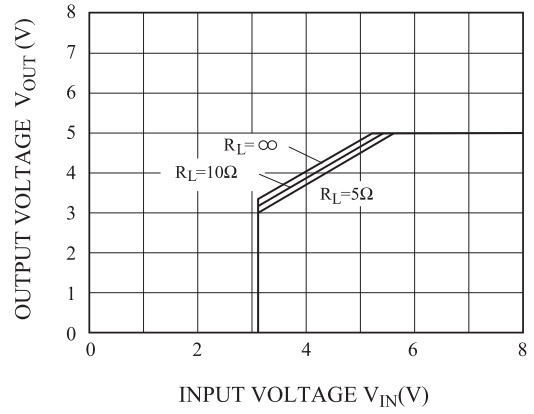

Fig. 12 V<sub>OUT</sub> - V<sub>IN</sub> (KIA78R06)

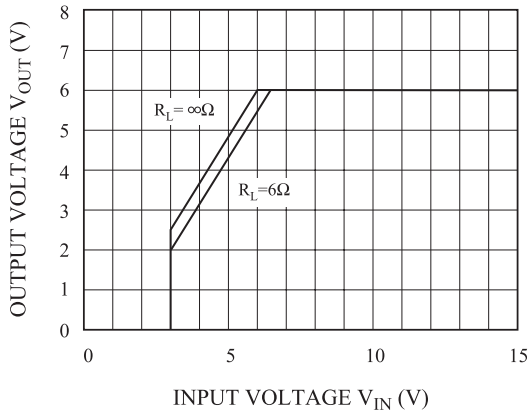

Fig. 13 V<sub>OUT</sub> - V<sub>IN</sub> (KIA78R08)

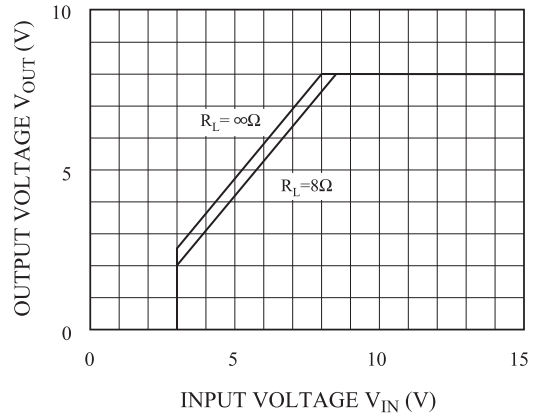

Fig. 14 V<sub>OUT</sub> - V<sub>IN</sub> (KIA78R09)

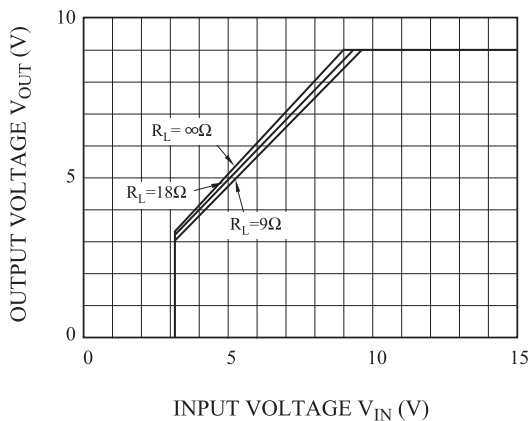
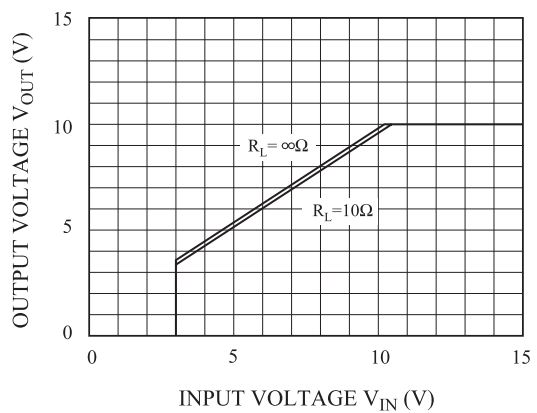

Fig. 15 V<sub>OUT</sub> - V<sub>IN</sub> (KIA78R10)



# KIA78R05PI~KIA78R35PI

Fig. 16  $V_{OUT} - V_{IN}$  (KIA78R12)

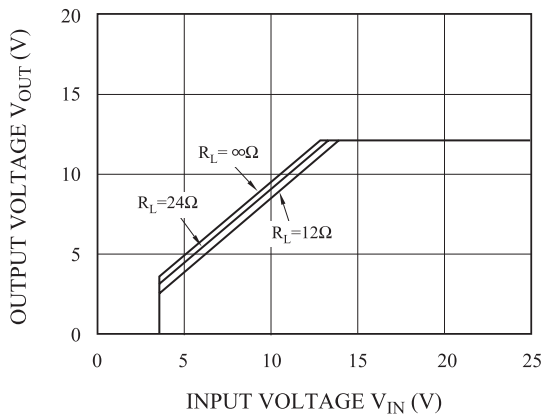

Fig. 17  $V_{OUT} - V_{IN}$  (KIA78R15)

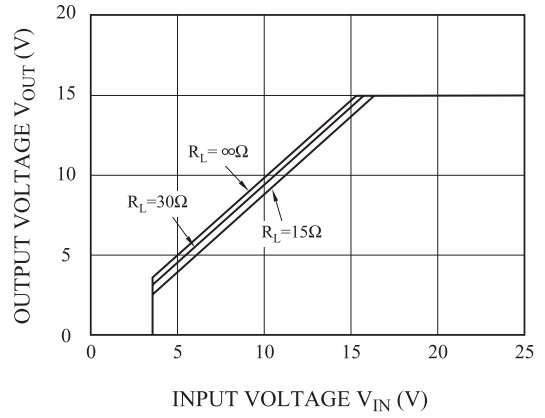

Fig. 18  $I_{BIAS} - V_{IN}$  (KIA78R05)

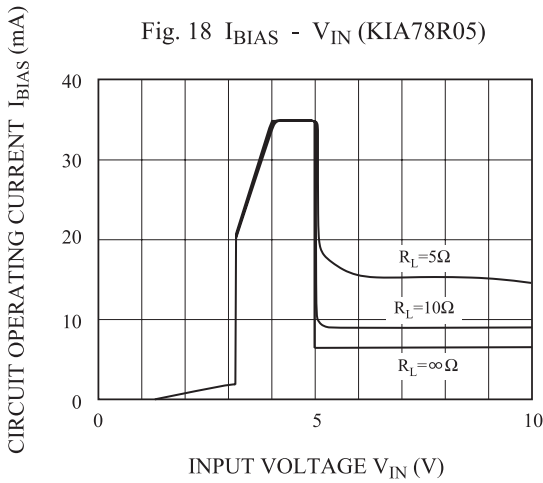

Fig. 19  $I_{BIAS} - V_{IN}$  (KIA78R06)

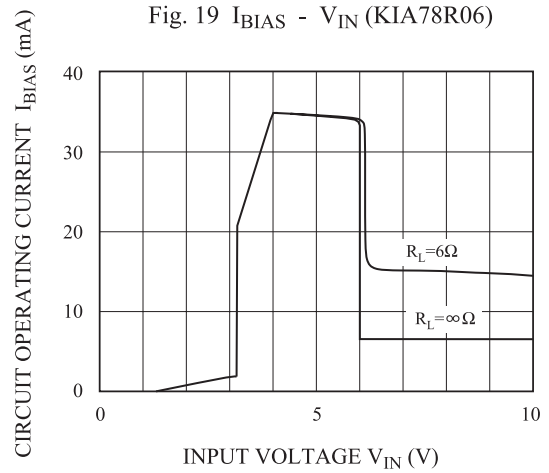

Fig. 20  $I_{BIAS} - V_{IN}$  (KIA78R08)

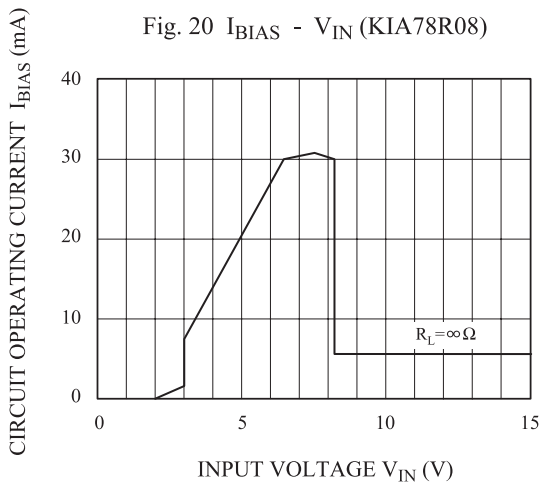
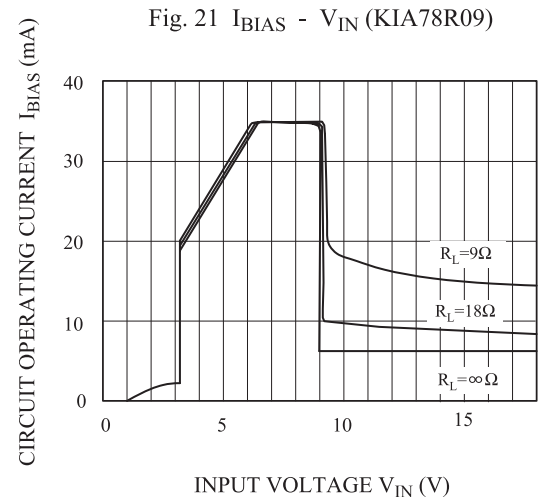

Fig. 21  $I_{BIAS} - V_{IN}$  (KIA78R09)



# KIA78R05PI~KIA78R35PI

Fig. 22  $I_{BIAS} - V_{IN}$  (KIA78R10)

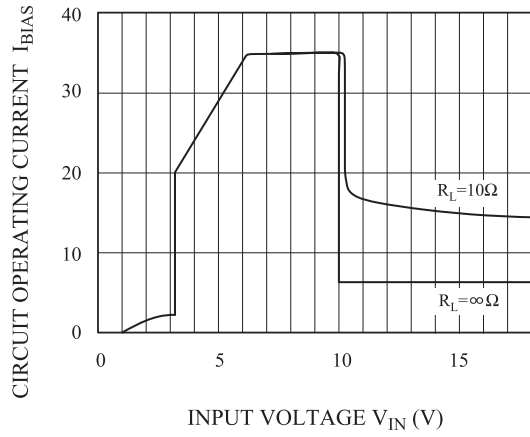

Fig. 23  $I_{BIAS} - V_{IN}$  (KIA78R12)

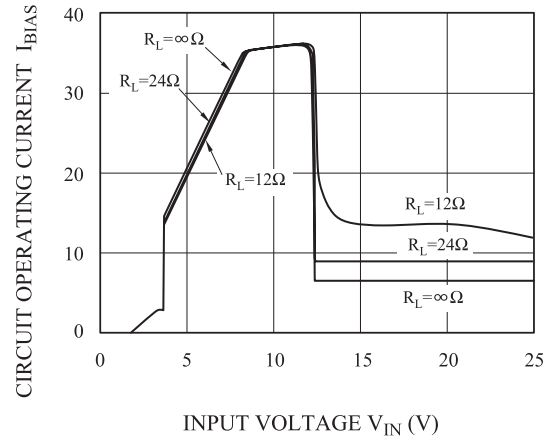

Fig. 24  $I_{BIAS} - V_{IN}$  (KIA78R15)

