

1A ADJUSTABLE LOW DROP VOLTAGE REGULATOR

The KIA78R00API is a Low Drop Voltage Regulator suitable for various electronic equipments. It provides constant voltage power source with TO-220-4 terminal lead full molded PKG. The Regulator has multi function such as over current protection, overheat protection.

FEATURES

- Adjustable Output Voltage (Range : 1.5~30V)
- 1.0A Output Low Drop Voltage Regulator.
- Built in Over Current Protection, Over Heat Protection Function.

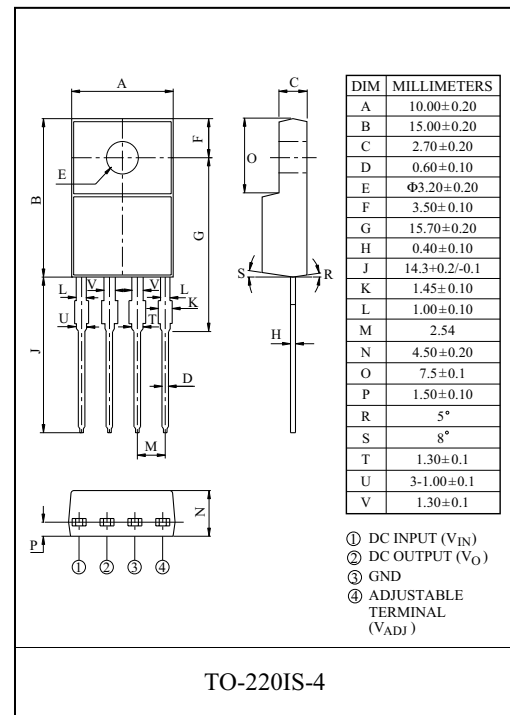

MAXIMUM RATINGS ($T_a=25\text{ }^\circ\text{C}$)

CHARACTERISTIC	SYMBOL	RATING	UNIT	Remark
Input Voltage	V_{IN}	35	V	-
Output Current	I_{OUT}	1	A	-
Power Dissipation 1	P_{D1}	1.5	W	No heatsink
Power Dissipation 2	P_{D2}	15	W	with heatsink
Junction Temperature	T_j	150	$^\circ\text{C}$	-
Operating Temperature	T_{opr}	-20~80	$^\circ\text{C}$	-
Storage Temperature	T_{stg}	-30~150	$^\circ\text{C}$	-
Soldering Temperature (10sec)	T_{sol}	260	$^\circ\text{C}$	-

KIA78R00API

ELECTRICAL CHARACTERISTICS

(Unless otherwise specified, $V_{IN}=15V$, $V_O=10V$, $I_O=0.5A$, $R_1=390\ \Omega$ (Note1 : $V_{IN}=0.95V_{out}$))

CHARACTERISTIC	SYMBOL	CONDITIONS	MIN.	TYP.	MAX.	UNIT	
Input Voltage	V_{IN}	-	4.5	-	35	V	
Output Voltage	V_O	$R_2=84\ \Omega$ to $8.7k\ \Omega$	1.5	-	30	V	
Load Regulation	Reg Load	$I_O=5mA \sim 1A$	-	-	2.0	%	
Line Regulation	Reg Line	$V_{IN}=11V \sim 28V$	-	-	2.5	%	
Ripple Rejection	R · R	$C_{ref}=0$	Refer to Fig.2	45	55	-	dB
		$C_{ref}=3.3\ \mu F$		55	65	-	
Reference Voltage	V_{ref}	-	1.26	1.29	1.32	V	
Temperature coefficient of reference Voltage	$T_C V_{ref}$	$T_j=0 \sim 125\ ^\circ C$	-	± 1.0	-	%	
DropOut Voltage	V_D	$I_O=1.0A$ (Note1)	-	-	0.5	V	
Quiescent Current	I_Q	$I_O=0A$	-	-	10	mA	

BLOCK DIAGRAM

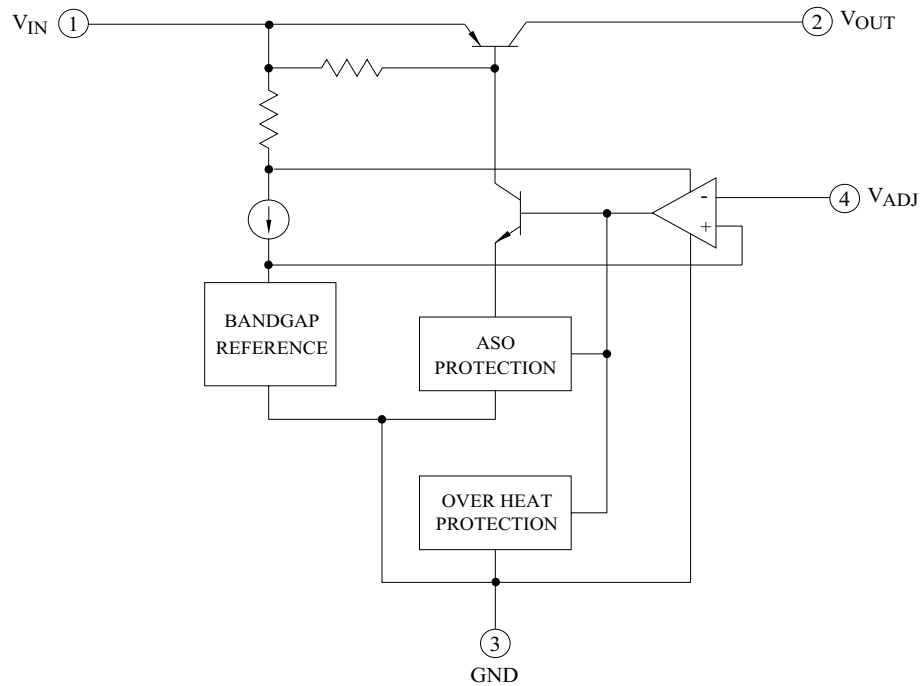

KIA78R00API

Fig. 1 Standard Test Circuit

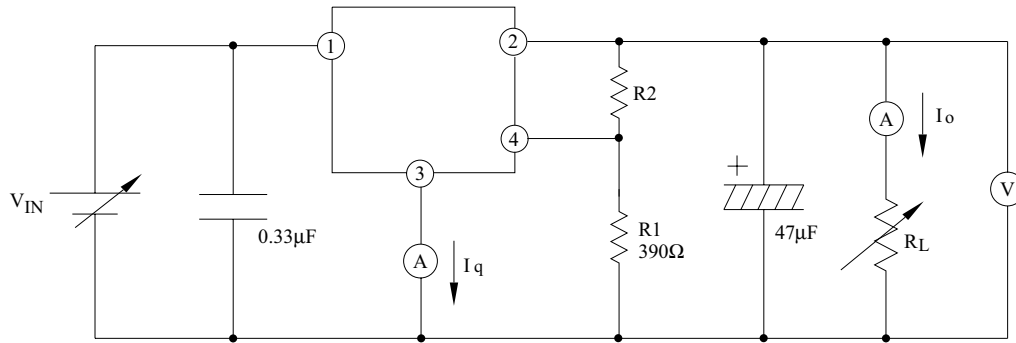

$$V_{OUT} = V_{ref} \times \left(1 + \frac{R2}{R1}\right) = 1.29 \times \left(1 + \frac{R2}{R1}\right)$$

Fig. 2 Ripple Rejection Circuit

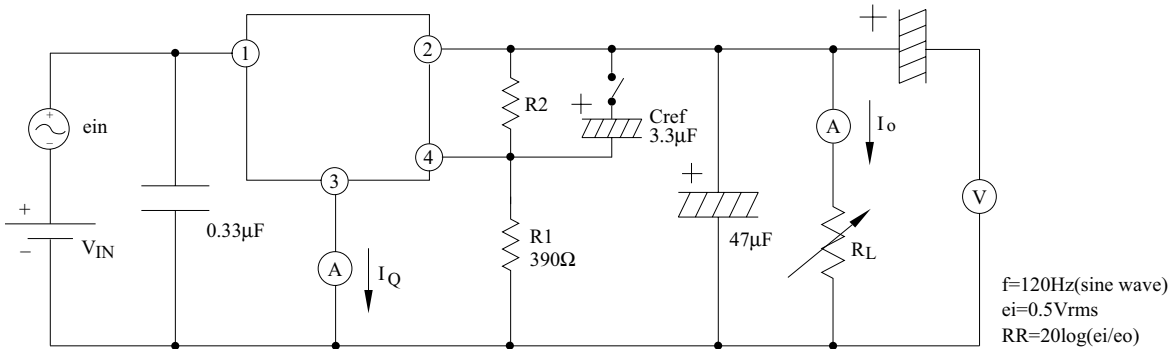
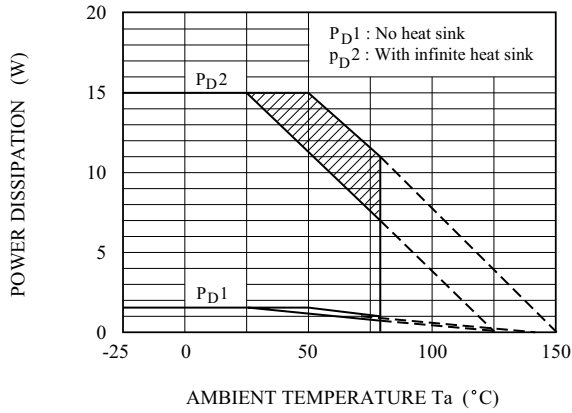

Fig. 3 $T_a - P_D$



Note) Oblique line portion : Overheat protection may operate in this area.

Fig. 4 $I_O - V_O$

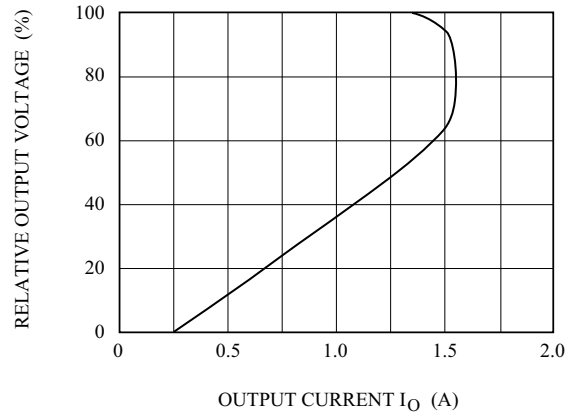

Fig. 5 $T_j - \Delta V_O$

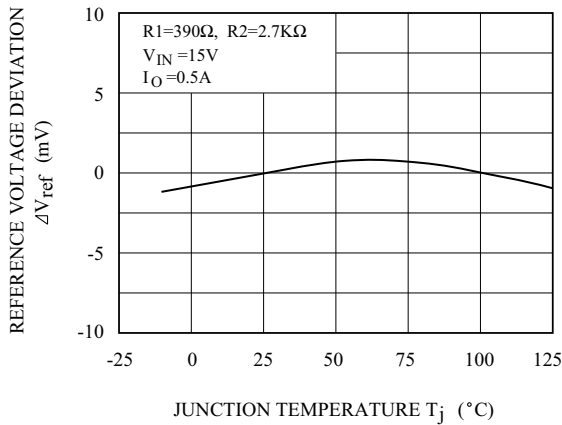

Fig. 6 $V_{IN} - V_O$

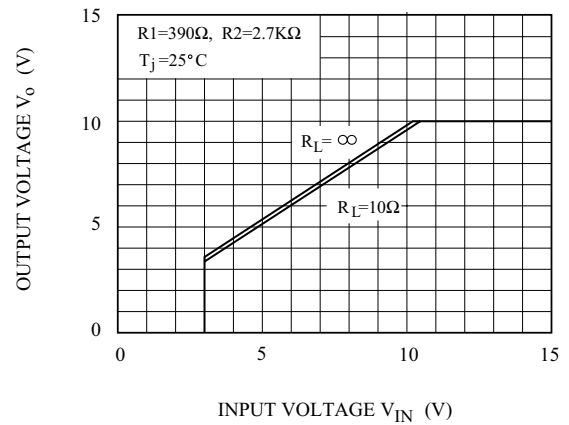

Fig. 7 $T_j - V_D$

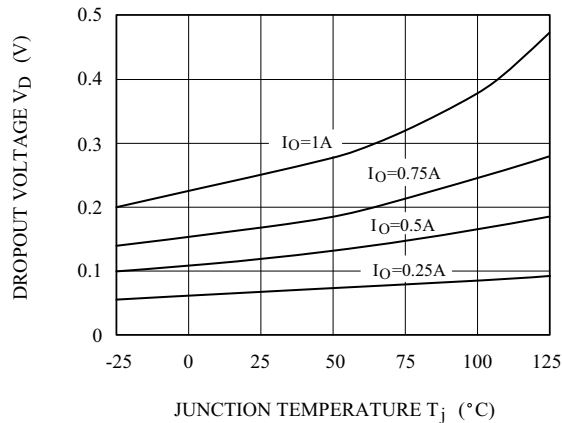
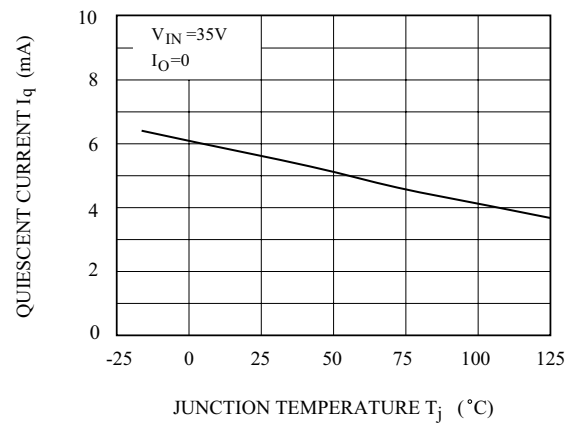

Fig. 8 $T_j - I_q$



KIA78R00API

Fig. 9 $f - RR$

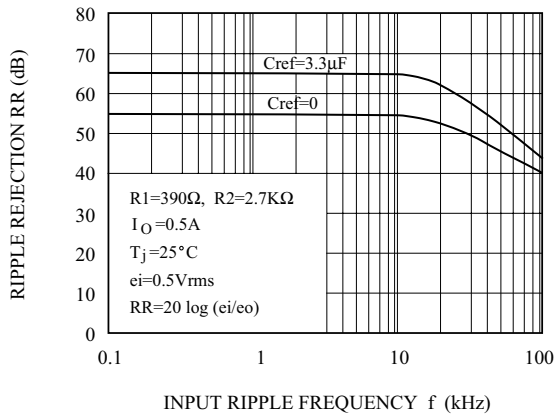

Fig. 10 $I_O - RR$

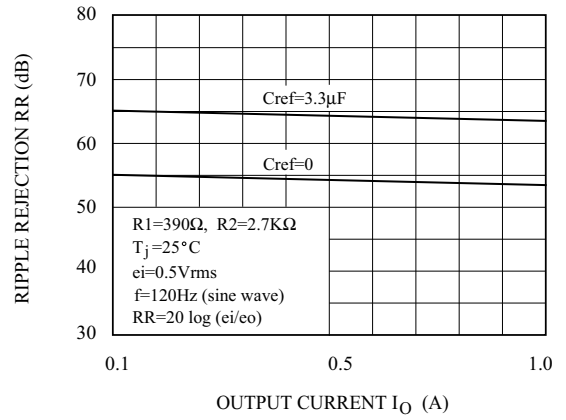

Fig. 11 $R_2 - V_O$

