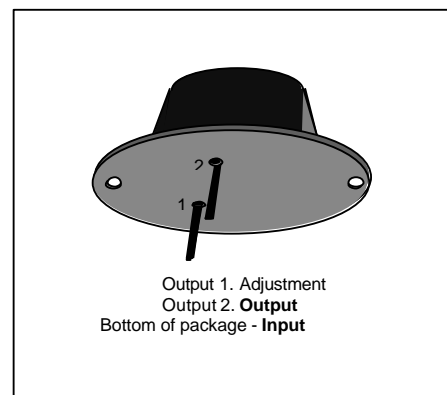

**IL1083****IC of adjustable voltage regulator of positive polarity with low residual voltage and load current 7,5 A**

IC IL1084 is a powerful adjustable voltage regulator of positive polarity with low residual voltage and load current 7,5 A.

IC of powerful adjustable voltage regulator with low residual voltage lower than 1,5A and reference voltage 1,25 V is purposed for producing constant temperature-stabilized voltage of positive polarity by means of the value set by external resistive divider and used in electronic equipment as a source of stabilized supply.

**Properties:**

- Reference voltage 1,25V
- Output current up to 7,5 A
- Input-output voltage difference,  $U_{IN} - U_O$  up to 30 V
- Residual voltage lower than 1,5 V
- Overload protection
- Embedded temperature protection
- Operation range of chip temperature from 0 up to +125°Ñ.

**Table 1 – Description of regulator IC pins in 3-pin package KT-9**

Pin No.	Description	Name
01	Adjustment	Adjust
Bottom of package	Output	Output
02	Input	Input



Ўрzhenevskogo 12, Minsk, 220064, Republic of Belarus  
 Fax: +375 (17) 278 28 22,  
 Phone: +375 (17) 278 07 11, 277 24 70, 277 24 61,  
 277 69 16  
 E-mail: belms@belms.belpak.minsk.by  
 URL: www.bms.by

**BELMICROSYSTEMS**

IL1083

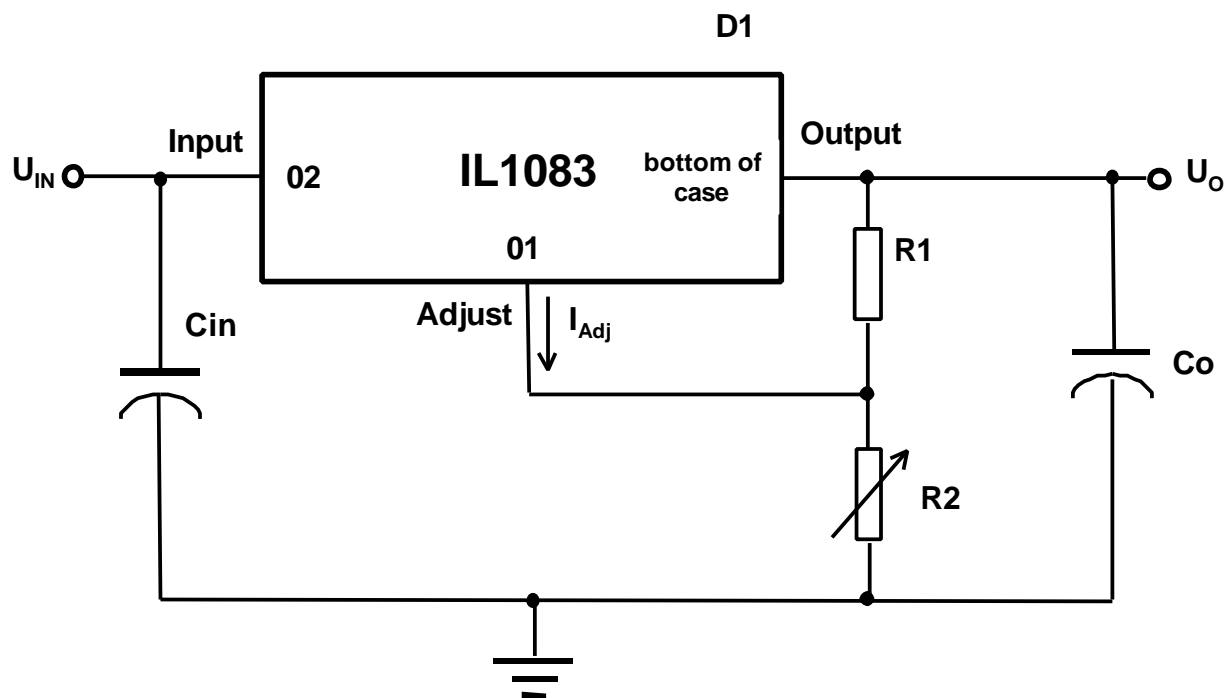

$\tilde{N}1, \tilde{N}2$  – smoothing capacitors,  $C1=10 \text{ mkF}$ ,  $\tilde{N}2=100 \text{ mkF}$  ( $Ta$ ),

D1 - IC,

R1, R2 - resistors,  $R1=121 \hat{\text{ i}} \pm 1\%$ , R2 – adjusted with accuracy 1%.

Output voltage  $U_o, V$ , is defined by formula:

$$U_o = U_{ref} \left(1 + \frac{R2}{R1}\right) + I_{Adj} R2,$$

Where  $U_{ref}$  - reference voltage, V,

$I_{Adj}$  - adjustment current, mA.

Since  $I_{ADJ}$  has values not more than 120 mA, inaccuracy dependent on this value for  $U_o$  – is minor.

Figure 1 – Connection circuit of adjustable voltage regulator



Ўрzhenevskogo 12, Minsk, 220064, Republic of Belarus  
 Fax: +375 (17) 278 28 22,  
 Phone: +375 (17) 278 07 11, 277 24 70, 277 24 61,  
 277 69 16  
 E-mail: belms@belms.belpak.minsk.by  
 URL: www.bms.by

**BELMICROSYSTEMS**

## IL1083

### TABLE 2 - TABLE OF ELECTRICAL CHARACTERISTICS

Characteristic, measurement unit	Symbol	Measurement mode	Standard		Temperature $T_J, ^\circ\text{C}$
			min	Max	
Reference voltage, V	$U_{ref}$	$I_O=10\text{mA}$ $(U_{IN} - U_O)=3\text{V}$	1,238	1,262	25±10
		$10\text{mA} \leq I_O \leq I_{FULL\ LOAD}$ $1,5\text{V} \leq (U_{IN} - U_O) \leq 25\text{V}$	1,225	1,270	0÷125
Reference voltage, V	$U_{ref}$	$I_O=10\text{mA}$ $(U_{IN} - U_O)=3\text{V}$	1,238	1,262	25±10
		$10\text{mA} \leq I_O \leq I_{FULL\ LOAD}$ $1,5\text{V} \leq (U_{IN} - U_O) \leq 25\text{V}$	1,225	1,270	0÷125
Change of output voltage when input voltage changes, %	Regline	$I_O=10\text{mA}$ , $1,5\text{V} \leq (U_{IN} - U_O) \leq 15\text{V}$	-	0,2	0÷125
		$I_O=10\text{mA}$ , $15\text{V} \leq (U_{IN} - U_O) \leq 30\text{V}$	-	0,5	0÷125
Change of output voltage when load current changes, %	Regload	$(U_{IN} - U_O) = 3\text{V}$ $10\text{mA} \leq I_O \leq I_{FULL\ LOAD}$	-	0,3	25±10
			-	0,4	0÷125
Residual voltage, V	$U_{ds}$	$\Delta U_{ref} = 1\%$ , $I_O = I_{FULL\ LOAD}$	-	1,5	0÷125
Maximum output current, A	$I_{O\ max}$	$(U_{IN} - U_O) = 5\text{V}$	8,0	-	0÷125
		$(U_{IN} - U_O) = 25\text{V}$	0,4	-	0÷125
Minimum output current, mA	$I_{O\ min}$	$(U_{IN} - U_O) = 25\text{V}$	-	10	0÷125
Thermostabilization, %/W	Regterm	$t_{\text{st}} = 30\text{min}$ , $T_A = 25^\circ\text{C}$		0,010	
Pulsation smoothing ratio, dB	RR	$f=120\text{Hz}$ , $\tilde{N}_{Adj}=25\mu\text{F}$ , $\tilde{N}_i=25\mu\text{F}$ $I_O=I_{FULL\ LOAD}$ , $(U_{IN} - U_O)=3\text{V}$	60	-	0÷125
Adjustment current, mA	$I_{Adj}$	$10\text{mA} \leq I_O \leq I_{FULL\ LOAD}$ $1,5\text{V} \leq (U_{IN} - U_O) \leq 25\text{V}$	-	120	0÷125
Change of adjustment current, mA	$\Delta I_{Adj}$	$10\text{mA} \leq I_O \leq I_{FULL\ LOAD}$ $1,5\text{V} \leq (U_{IN} - U_O) \leq 25\text{V}$	-	5	0÷125
Ratio of output voltage temporary instability, %	S	$1000 \div ; T_J = 125^\circ\text{C}$ (when testing)	-	1	25±10

**Notes:**

1 Measurement of electrical characteristics is carried out when capacitance  $\tilde{N}_{IN}=10\text{mkF}$  is connected to the input and  $\tilde{N}_i=100\text{mkF}$  – to the output;

2 Reference voltage  $U_{ref}$  in adjustable regulator is measured between outputs Output and Adjust on resistance R1 (figure 1);

3 Parameters stipulated in table 1 are ensured for constant chip temperature  $T_J$ . Measurement of parameters should be performed using heatsink and pulse technique;

4  $I_{FULL\ LOAD}$  – value of maximum output current dependent on input-output voltage difference  $(U_{IN} - U_O)$  with power dissipation in package  $\hat{Q}=28 - 30\text{W}$ .



Ćorzhenevskogo 12, Minsk, 220064, Republic of Belarus  
 Fax: +375 (17) 278 28 22,  
 Phone: +375 (17) 278 07 11, 277 24 70, 277 24 61,  
 277 69 16  
 E-mail: belms@belms.belpak.minsk.by  
 URL: www.bms.by

## BELMICROSYSTEMS

## IL1083

**Table 3 - Typical values of electrical characteristics**

Characteristic, Measurement unit	Symbol	Measurement mode	Typical value
Adjustment current, mA	$I_{Adj}$	$T_J = 25^\circ\text{C}$	55
Temperature ratio of output voltage instability, %	TS	$T_J = 0\div 125^\circ\text{C}$	0,5
Noise voltage on output, (%)	$U_{n\text{rms}}$	$T_J = 25^\circ\text{C}$ $10\ \mu\text{s} \leq f \leq 10\ \text{kHz}$	0,003

**Table 4 - Table of maximum and absolute maximum ratings**

Parameter	Measure- ment unit	Maximum ratings		Absolute maxi- mum ratings	
		min	max	min	max
Input-output voltage difference, $U_N - U_O$	V	2,77	30	0	31
Chip temperature, $\dot{Q}_j$	$^\circ\text{C}$	0	125	-65	150
Storage temperature, $\dot{Q}_{stg}$	$^\circ\text{C}$			-65	150



Ўрzhenevskogo 12, Minsk, 220064, Republic of Belarus

Fax: +375 (17) 278 28 22,

Phone: +375 (17) 278 07 11, 277 24 70, 277 24 61,

277 69 16

E-mail: belms@belms.belpak.minsk.by

URL: www.bms.by

**BELMICROSYSTEMS**