

REALTEK

ALC272
(PN: ALC272-GR)

4 CHANNEL HIGH DEFINITION AUDIO CODEC

DATASHEET

Rev. 1.0
21 May 2008
Track ID: JATR-1076-21



Realtek Semiconductor Corp.
No. 2, Innovation Road II, Hsinchu Science Park, Hsinchu 300, Taiwan
Tel.: +886-3-578-0211. Fax: +886-3-577-6047
www.realtek.com.tw

COPYRIGHT

©2008 Realtek Semiconductor Corp. All rights reserved. No part of this document may be reproduced, transmitted, transcribed, stored in a retrieval system, or translated into any language in any form or by any means without the written permission of Realtek Semiconductor Corp.

DISCLAIMER

Realtek provides this document “as is”, without warranty of any kind, neither expressed nor implied, including, but not limited to, the particular purpose. Realtek may make improvements and/or changes in this document or in the product described in this document at any time. This document could include technical inaccuracies or typographical errors.

TRADEMARKS

Realtek is a trademark, of Realtek Semiconductor Corporation. Other names mentioned in this document are trademarks/registered trademarks of their respective owners.

USING THIS DOCUMENT

This document is intended for the hardware and software engineer’s general information on the Realtek ALC272 Audio Codec IC.

Though every effort has been made to ensure that this document is current and accurate, more information may have become available subsequent to the production of this guide. In that event, please contact your Realtek representative for additional information that may help in the development process.

REVISION HISTORY

| Revision | Release Date | Summary |
|-----------------|---------------------|----------------|
| 1.0 | 2008/05/21 | First release. |

Table of Contents

| | |
|---|-----------|
| 1. GENERAL DESCRIPTION | 1 |
| 2. FEATURES | 2 |
| 2.1. HARDWARE FEATURES | 2 |
| 2.2. SOFTWARE FEATURES..... | 3 |
| 3. SYSTEM APPLICATIONS | 4 |
| 4. BLOCK DIAGRAM | 5 |
| 5. PIN ASSIGNMENTS | 6 |
| 5.1. PACKAGE AND VERSION IDENTIFICATION | 6 |
| 6. PIN DESCRIPTIONS | 7 |
| 6.1. DIGITAL I/O PINS | 7 |
| 6.2. ANALOG I/O PINS | 7 |
| 6.3. FILTER/REFERENCE/NOT CONNECT | 8 |
| 6.4. POWER/GROUND..... | 8 |
| 7. HIGH DEFINITION AUDIO LINK PROTOCOL | 9 |
| 7.1. LINK SIGNALS | 9 |
| 7.1.1. <i>Signal Definitions</i> | 10 |
| 7.1.2. <i>Signaling Topology</i> | 11 |
| 7.2. FRAME COMPOSITION | 12 |
| 7.2.1. <i>Outbound Frame – Single SDO</i> | 12 |
| 7.2.2. <i>Outbound Frame – Multiple SDOs</i> | 13 |
| 7.2.3. <i>Inbound Frame – Single SDI</i> | 14 |
| 7.2.4. <i>Inbound Frame – Multiple SDIs</i> | 15 |
| 7.2.5. <i>Variable Sample Rates</i> | 15 |
| 7.3. RESET AND INITIALIZATION | 18 |
| 7.3.1. <i>Link Reset</i> | 18 |
| 7.3.2. <i>Codec Reset</i> | 19 |
| 7.3.3. <i>Codec Initialization Sequence</i> | 20 |
| 7.4. VERB AND RESPONSE FORMAT | 20 |
| 7.4.1. <i>Command Verb Format</i> | 20 |
| 7.4.2. <i>Response Format</i> | 23 |
| 7.4.3. <i>Double Function Reset</i> | 23 |
| 7.5. POWER MANAGEMENT..... | 24 |
| 8. SUPPORTED VERBS AND PARAMETERS | 26 |
| 8.1. VERB – GET PARAMETERS (VERB ID=F00H)..... | 26 |
| 8.1.1. <i>Parameter – Vendor ID (Verb ID=F00h, Parameter ID=00h)</i> | 26 |
| 8.1.2. <i>Parameter – Revision ID (Verb ID=F00h, Parameter ID=02h)</i> | 26 |
| 8.1.3. <i>Parameter – Subordinate Node Count (Verb ID=F00h, Parameter ID=04h)</i> | 27 |
| 8.1.4. <i>Parameter – Function Group Type (Verb ID=F00h, Parameter ID=05h)</i> | 27 |
| 8.1.5. <i>Parameter– Audio Function Capabilities (Verb ID=F00h, Parameter ID=08h)</i> | 27 |
| 8.1.6. <i>Parameter – Audio Widget Capabilities (Verb ID=F00h, Parameter ID=09h)</i> | 28 |
| 8.1.7. <i>Parameter – Supported PCM Size, Rates (Verb ID=F00h, Parameter ID=0Ah)</i> | 29 |
| 8.1.8. <i>Parameter – Supported Stream Formats (Verb ID=F00h, Parameter ID=0Bh)</i> | 30 |
| 8.1.9. <i>Parameter – Pin Capabilities (Verb ID=F00h, Parameter ID=0Ch)</i> | 30 |
| 8.1.10. <i>Parameter– Amplifier Capabilities (Verb ID=F00h, Input Amplifier Parameter ID=0Dh)</i> | 31 |

| | | |
|-----------|---|-----------|
| 8.1.11. | Parameter – Amplifier Capabilities (Verb ID=F00h, Output Amplifier Parameter ID=12h) | 31 |
| 8.1.12. | Parameter – Connect List Length (Verb ID=F00h, Parameter ID=0Eh) | 32 |
| 8.1.13. | Parameter – Supported Power States (Verb ID=F00h, Parameter ID=0Fh) | 32 |
| 8.1.14. | Parameter – Processing Capabilities (Verb ID=F00h, Parameter ID=10h) | 33 |
| 8.1.15. | Parameter – GPIO Capabilities (Verb ID=F00h, Parameter ID=11h) | 33 |
| 8.1.16. | Parameter – Volume Knob Capabilities (Verb ID=F00h, Parameter ID=13h) | 33 |
| 8.2. | VERB – GET CONNECTION SELECT CONTROL (VERB ID=F01H) | 34 |
| 8.3. | VERB – SET CONNECTION SELECT (VERB ID=701H) | 35 |
| 8.4. | VERB – GET CONNECTION LIST ENTRY (VERB ID=F02H) | 35 |
| 8.5. | VERB – GET PROCESSING STATE (VERB ID=F03H) | 40 |
| 8.6. | VERB – SET PROCESSING STATE (VERB ID=703H) | 40 |
| 8.7. | VERB – GET COEFFICIENT INDEX (VERB ID=DH) | 41 |
| 8.8. | VERB – SET COEFFICIENT INDEX (VERB ID=5H) | 41 |
| 8.9. | VERB – GET PROCESSING COEFFICIENT (VERB ID=CH) | 41 |
| 8.10. | VERB – SET PROCESSING COEFFICIENT (VERB ID=4H) | 42 |
| 8.11. | VERB – GET AMPLIFIER GAIN (VERB ID=BH) | 42 |
| 8.12. | VERB – SET AMPLIFIER GAIN (VERB ID=3H) | 45 |
| 8.13. | VERB – GET CONVERTER FORMAT (VERB ID=AH) | 46 |
| 8.14. | VERB – SET CONVERTER FORMAT (VERB ID=2H) | 47 |
| 8.15. | VERB – GET POWER STATE (VERB ID=F05H) | 48 |
| 8.16. | VERB – SET POWER STATE (VERB ID=705H) | 49 |
| 8.17. | VERB – GET CONVERTER STREAM, CHANNEL (VERB ID=F06H) | 49 |
| 8.18. | VERB – SET CONVERTER STREAM, CHANNEL (VERB ID=706H) | 50 |
| 8.19. | VERB – GET PIN WIDGET CONTROL (VERB ID=F07H) | 50 |
| 8.20. | VERB – SET PIN WIDGET CONTROL (VERB ID=707H) | 51 |
| 8.21. | VERB – GET UNSOLICITED RESPONSE CONTROL (VERB ID=F08H) | 52 |
| 8.22. | VERB – SET UNSOLICITED RESPONSE CONTROL (VERB ID=708H) | 52 |
| 8.23. | VERB – GET PIN SENSE (VERB ID=F09H) | 53 |
| 8.24. | VERB – EXECUTE PIN SENSE (VERB ID=709H) | 53 |
| 8.25. | VERB – GET CONFIGURATION DEFAULT (VERB ID=F1CH/F1DH/F1EH/F1FH) | 54 |
| 8.26. | VERB – SET CONFIGURATION DEFAULT BYTES 0, 1, 2, 3 (VERB ID=71CH/71DH/71EH/71FH) | 54 |
| 8.27. | VERB – GET BEEP GENERATOR (VERB ID=F0AH) | 55 |
| 8.28. | VERB – SET BEEP GENERATOR (VERB ID=70AH) | 55 |
| 8.29. | VERB – GET GPIO DATA (VERB ID= F15H) | 56 |
| 8.30. | VERB – SET GPIO DATA (VERB ID= 715H) | 56 |
| 8.31. | VERB – GET GPIO ENABLE MASK (VERB ID=F16H) | 57 |
| 8.32. | VERB – SET GPIO ENABLE MASK (VERB ID=716H) | 57 |
| 8.33. | VERB – GET GPIO DIRECTION (VERB ID=F17H) | 58 |
| 8.34. | VERB – SET GPIO DIRECTION (VERB ID=717H) | 58 |
| 8.35. | VERB – GET GPIO UNSOLICITED RESPONSE ENABLE MASK (VERB ID=F19H) | 59 |
| 8.36. | VERB – SET GPIO UNSOLICITED RESPONSE ENABLE MASK (VERB ID=719H) | 59 |
| 8.37. | VERB – GET DIGITAL CONVERTER CONTROL 1 & CONTROL 2 (VERB ID= F0DH, F0EH) | 60 |
| 8.38. | VERB – SET DIGITAL CONVERTER CONTROL 1 & CONTROL 2 (VERB ID=70DH, 70EH) | 61 |
| 8.39. | VERB – GET SUBSYSTEM ID [31:0] (VERB ID=F20H/F21H/D22H/F23H) | 62 |
| 8.40. | VERB – SET SUBSYSTEM ID [31:0] (VERB ID=723H/722H/721H/720H FOR [31:24]/[23:16]/[15:8]/[7:0]) | 62 |
| 8.41. | VERB – GET/SET EAPD CONTROL (VERB ID=F0CH FOR GET, 70CH FOR SET) | 63 |
| 8.42. | VERB – FUNCTION RESET (VERB ID=7FFH) | 64 |
| 9. | ELECTRICAL CHARACTERISTICS | 65 |
| 9.1. | DC CHARACTERISTICS | 65 |
| 9.1.1. | Absolute Maximum Ratings | 65 |
| 9.1.2. | Threshold Voltage | 65 |
| 9.1.3. | SPDIF Output Characteristics | 66 |
| 9.1.4. | Digital Filter Characteristics | 66 |
| 9.2. | AC CHARACTERISTICS | 67 |

| | | |
|------------|--|-----------|
| 9.2.1. | Link Reset and Initialization Timing..... | 67 |
| 9.2.2. | Link Timing Parameters at the Codec..... | 68 |
| 9.2.3. | SPDIF Output Timing..... | 69 |
| 9.2.4. | Test Mode..... | 69 |
| 9.3. | ANALOG PERFORMANCE..... | 70 |
| 10. | APPLICATION CIRCUITS..... | 71 |
| 10.1. | FILTER CONNECTION..... | 71 |
| 10.2. | ONBOARD FRONT PANEL HEADER CONNECTION AND FRONT PANEL I/O..... | 72 |
| 10.3. | POWER SUPPLY AND ANALOG INPUT/OUTPUT CONNECTION..... | 73 |
| 10.4. | OPTIONAL SPDIF OUTPUT..... | 74 |
| 11. | MECHANICAL DIMENSIONS..... | 75 |
| 12. | ORDERING INFORMATION..... | 76 |

List of Tables

| | | |
|-----------|---|----|
| TABLE 1. | DIGITAL I/O PINS..... | 7 |
| TABLE 2. | ANALOG I/O PINS..... | 7 |
| TABLE 3. | FILTER/REFERENCE..... | 8 |
| TABLE 4. | POWER/GROUND..... | 8 |
| TABLE 5. | LINK RESET#..... | 10 |
| TABLE 6. | HDA SIGNAL DEFINITIONS..... | 10 |
| TABLE 7. | DEFINED SAMPLE RATE AND TRANSMISSION RATE..... | 16 |
| TABLE 8. | 48kHz VARIABLE RATE OF DELIVERY TIMING..... | 16 |
| TABLE 9. | 44.1kHz VARIABLE RATE OF DELIVERY TIMING..... | 17 |
| TABLE 10. | 40-BIT COMMANDS IN 4-BIT VERB FORMAT..... | 20 |
| TABLE 11. | 40-BIT COMMANDS IN 12-BIT VERB FORMAT..... | 20 |
| TABLE 12. | SUPPORTED COMMANDS..... | 21 |
| TABLE 13. | SUPPORTED PARAMETERS..... | 22 |
| TABLE 14. | SOLICITED RESPONSE FORMAT..... | 23 |
| TABLE 15. | UNSOLICITED RESPONSE FORMAT..... | 23 |
| TABLE 16. | SYSTEM POWER STATE DEFINITIONS..... | 25 |
| TABLE 17. | POWER CONTROLS IN NID 01H..... | 25 |
| TABLE 18. | POWERED DOWN CONDITIONS..... | 25 |
| TABLE 19. | VERB – GET PARAMETERS (VERB ID=F00H)..... | 26 |
| TABLE 20. | PARAMETER – VENDOR ID (VERB ID=F00H, PARAMETER ID=00H)..... | 26 |
| TABLE 21. | PARAMETER – REVISION ID (VERB ID=F00H, PARAMETER ID=02H)..... | 26 |
| TABLE 22. | PARAMETER – SUBORDINATE NODE COUNT (VERB ID=F00H, PARAMETER ID=04H)..... | 27 |
| TABLE 23. | PARAMETER – FUNCTION GROUP TYPE (VERB ID=F00H, PARAMETER ID=05H)..... | 27 |
| TABLE 24. | PARAMETER – AUDIO FUNCTION CAPABILITIES (VERB ID=F00H, PARAMETER ID=08H)..... | 27 |
| TABLE 25. | PARAMETER – AUDIO WIDGET CAPABILITIES (VERB ID=F00H, PARAMETER ID=09H)..... | 28 |
| TABLE 26. | PARAMETER – SUPPORTED PCM SIZE, RATES (VERB ID=F00H, PARAMETER ID=0AH)..... | 29 |
| TABLE 27. | PARAMETER – SUPPORTED STREAM FORMATS (VERB ID=F00H, PARAMETER ID=0BH)..... | 30 |
| TABLE 28. | PARAMETER – PIN CAPABILITIES (VERB ID=F00H, PARAMETER ID=0CH)..... | 30 |
| TABLE 29. | PARAMETER – AMPLIFIER CAPABILITIES (VERB ID=F00H, INPUT AMPLIFIER PARAMETER ID=0DH)..... | 31 |
| TABLE 30. | PARAMETER – AMPLIFIER CAPABILITIES (VERB ID=F00H, OUTPUT AMPLIFIER PARAMETER ID=12H)..... | 31 |
| TABLE 31. | PARAMETER – CONNECT LIST LENGTH (VERB ID=F00H, PARAMETER ID=0EH)..... | 32 |
| TABLE 32. | PARAMETER – SUPPORTED POWER STATES (VERB ID=F00H, PARAMETER ID=0FH)..... | 32 |
| TABLE 33. | PARAMETER – PROCESSING CAPABILITIES (VERB ID=F00H, PARAMETER ID=10H)..... | 33 |
| TABLE 34. | PARAMETER – GPIO CAPABILITIES (VERB ID=F00H, PARAMETER ID=11H)..... | 33 |
| TABLE 35. | PARAMETER – VOLUME KNOB CAPABILITIES (VERB ID=F00H, PARAMETER ID=13H)..... | 33 |
| TABLE 36. | VERB – GET CONNECTION SELECT CONTROL (VERB ID=F01H)..... | 34 |
| TABLE 37. | VERB – SET CONNECTION SELECT (VERB ID=701H)..... | 35 |
| TABLE 38. | VERB – GET CONNECTION LIST ENTRY (VERB ID=F02H)..... | 35 |
| TABLE 39. | VERB – GET PROCESSING STATE (VERB ID=F03H)..... | 40 |
| TABLE 40. | VERB – SET PROCESSING STATE (VERB ID=703H)..... | 40 |
| TABLE 41. | VERB – GET COEFFICIENT INDEX (VERB ID=DH)..... | 41 |
| TABLE 42. | VERB – SET COEFFICIENT INDEX (VERB ID=5H)..... | 41 |
| TABLE 43. | VERB – GET PROCESSING COEFFICIENT (VERB ID=CH)..... | 41 |
| TABLE 44. | VERB – SET PROCESSING COEFFICIENT (VERB ID=4H)..... | 42 |
| TABLE 45. | VERB – GET AMPLIFIER GAIN (VERB ID=BH)..... | 42 |
| TABLE 46. | VERB – SET AMPLIFIER GAIN (VERB ID=3H)..... | 45 |
| TABLE 47. | VERB – GET CONVERTER FORMAT (VERB ID=AH)..... | 46 |
| TABLE 48. | GET CONVERTER FORMAT SUPPORT..... | 46 |
| TABLE 49. | VERB – SET CONVERTER FORMAT (VERB ID=2H)..... | 47 |
| TABLE 50. | VERB – GET POWER STATE (VERB ID=F05H)..... | 48 |
| TABLE 51. | VERB – SET POWER STATE (VERB ID=705H)..... | 49 |
| TABLE 52. | VERB – GET CONVERTER STREAM, CHANNEL (VERB ID=F06H)..... | 49 |

| | |
|---|----|
| TABLE 53. VERB – SET CONVERTER STREAM, CHANNEL (VERB ID=706H) | 50 |
| TABLE 54. VERB – GET PIN WIDGET CONTROL (VERB ID=F07H) | 50 |
| TABLE 55. VERB – SET PIN WIDGET CONTROL (VERB ID=707H) | 51 |
| TABLE 56. VERB – GET UNSOLICITED RESPONSE CONTROL (VERB ID=F08H) | 52 |
| TABLE 57. VERB – SET UNSOLICITED RESPONSE CONTROL (VERB ID=708H) | 52 |
| TABLE 58. VERB – GET PIN SENSE (VERB ID=F09H) | 53 |
| TABLE 59. VERB – EXECUTE PIN SENSE (VERB ID=709H) | 53 |
| TABLE 60. VERB – GET CONFIGURATION DEFAULT (VERB ID=F1CH/F1DH/F1EH/F1FH) | 54 |
| TABLE 61. VERB – SET CONFIGURATION DEFAULT BYTES 0, 1, 2, 3 (VERB ID=71CH/71DH/71EH/71FH) | 54 |
| TABLE 62. VERB – GET BEEP GENERATOR (VERB ID= F0AH) | 55 |
| TABLE 63. VERB – SET BEEP GENERATOR (VERB ID= 70AH) | 55 |
| TABLE 64. VERB – GET GPIO DATA (VERB ID= F15H) | 56 |
| TABLE 65. VERB – SET GPIO DATA (VERB ID= 715H) | 56 |
| TABLE 66. VERB – GET GPIO ENABLE MASK (VERB ID= F16H) | 57 |
| TABLE 67. VERB – SET GPIO ENABLE MASK (VERB ID=716H) | 57 |
| TABLE 68. VERB – GET GPIO DIRECTION (VERB ID=F17H) | 58 |
| TABLE 69. VERB – SET GPIO DIRECTION (VERB ID=717H) | 58 |
| TABLE 70. VERB – GET GPIO UNSOLICITED RESPONSE ENABLE MASK (VERB ID=F19H) | 59 |
| TABLE 71. VERB – SET GPIO UNSOLICITED RESPONSE ENABLE MASK (VERB ID=719H) | 59 |
| TABLE 72. VERB – GET DIGITAL CONVERTER CONTROL 1 & CONTROL 2 (VERB ID= F0DH, F0EH) | 60 |
| TABLE 73. VERB – SET DIGITAL CONVERTER CONTROL 1 & CONTROL 2 (VERB ID=70DH, 70EH) | 61 |
| TABLE 74. VERB – GET SUBSYSTEM ID [31:0] (VERB ID=F20H/F21H/F22H/F23H) | 62 |
| TABLE 75. VERB – SET SUBSYSTEM ID [31:0] (VERB ID=723H/722H/721H/720H FOR [31:24]/[23:16]/[15:8]/[7:0]) | 62 |
| TABLE 76. VERB – GET EAPD CONTROL (VERB ID=F0CH) | 63 |
| TABLE 77. VERB – SET EAPD CONTROL (VERB ID=70CH) | 63 |
| TABLE 78. VERB – FUNCTION RESET (VERB ID=7FFH) | 64 |
| TABLE 79. ABSOLUTE MAXIMUM RATINGS | 65 |
| TABLE 80. THRESHOLD VOLTAGE | 65 |
| TABLE 81. SPDIF OUTPUT CHARACTERISTICS | 66 |
| TABLE 82. DIGITAL FILTER CHARACTERISTICS | 66 |
| TABLE 83. LINK RESET AND INITIALIZATION TIMING | 67 |
| TABLE 84. LINK TIMING PARAMETERS AT THE CODEC | 68 |
| TABLE 85. SPDIF OUTPUT TIMING | 69 |
| TABLE 86. ANALOG PERFORMANCE | 70 |
| TABLE 87. ORDERING INFORMATION | 76 |

List of Figures

| | |
|--|----|
| FIGURE 1. BLOCK DIAGRAM | 5 |
| FIGURE 2. PIN ASSIGNMENTS | 6 |
| FIGURE 3. HDA LINK PROTOCOL..... | 9 |
| FIGURE 4. BIT TIMING..... | 10 |
| FIGURE 5. SIGNALING TOPOLOGY | 11 |
| FIGURE 6. SDO OUTBOUND FRAME..... | 12 |
| FIGURE 7. SDO STREAM TAG IS INDICATED IN SYNC..... | 12 |
| FIGURE 8. STRIPED STREAM ON MULTIPLE SDOs..... | 13 |
| FIGURE 9. SDI INBOUND STREAM..... | 14 |
| FIGURE 10. SDI STREAM TAG AND DATA | 14 |
| FIGURE 11. CODEC TRANSMITS DATA OVER MULTIPLE SDIS | 15 |
| FIGURE 12. LINK RESET TIMING..... | 19 |
| FIGURE 13. CODEC INITIALIZATION SEQUENCE..... | 20 |
| FIGURE 14. RESUME FROM EXTERNAL EVENT (WAKE-UP EVENT)..... | 24 |
| FIGURE 15. LINK RESET AND INITIALIZATION TIMING | 67 |
| FIGURE 16. LINK SIGNAL TIMING..... | 68 |
| FIGURE 17. OUTPUT TIMING..... | 69 |
| FIGURE 18. FILTER CONNECTION | 71 |
| FIGURE 19. ONBOARD FRONT PANEL HEADER CONNECTION AND FRONT PANEL I/O | 72 |
| FIGURE 20. ANALOG INPUT/OUTPUT CONNECTION..... | 73 |
| FIGURE 21. OPTIONAL SPDIF OUTPUT | 74 |

1. General Description

The ALC272 is a High Definition Audio Codec that meets the current WLP3.10 (Windows Logo Program) audio requirements for Windows Vista systems.

Featuring two stereo DACs, two stereo ADCs, legacy analog input to analog output mixing, one stereo digital microphone converter, and two independent SPDIF output converters, the ALC272 provides a fully integrated audio solution for multimedia desktop and mobile PCs, and ultra mobile devices.

The ALC272 integrates two stereo ADCs and two stereo digital microphone converters to support simultaneous analog microphone recording and up to 4 channel digital microphone array recording, and features Acoustic Echo Cancellation (AEC), Beam Forming (BF), and Noise Suppression (NS) for voice applications.

Multiple analog IO (except MONO, PCBEEP, and HP-OUT) are input and output capable, and provide headphone amplifiers. Four linear headphone amplifiers are integrated to drive earphones on port-A, port-D, port-E and port-F. The fifth headphone amplifier on port-I (HPOUT) is designed to drive an earphone without the need for external DC blocking capacitors, reducing pop noise and enhancing sound quality.

The ALC272 provides two independent SPDIF outputs and supports 16/20/24-bit SPDIF output with a sampling rate of up to 192kHz, offering easy connection of PCs to high quality consumer electronic products such as digital decoders and speakers. In addition to the standard (primary) SPDIF output function, the ALC272 features another independent (secondary) SPDIF-OUT output and converters that transport digital audio output to a High Definition Media Interface (HDMI) transmitter (becoming more common in high-end PCs).

In addition to the audio functions, the ALC272 supports enhanced power management. Its power management design conforms to Intel's Audio Codec low power state white paper and is ECR compliant, reducing power consumption when the audio function is not being used, and offering jack detection wake-up when the system is in power down state so as to extend battery life for mobile systems without sacrificing audio features.

The ALC272 supports host audio controller from the Intel ICH series chipset, and also from any other HDA compatible audio controller. With software utilities like Karaoke mode, environment emulation, multi-band software equalizer, dynamic range compressor and extender, optional Dolby® Digital Live, DTS® CONNECT™, Dolby® Home Theater, and SRS® programs, the ALC272 provides an excellent home entertainment package and game experience for PC users.

2. Features

2.1. Hardware Features

- Meets performance and function requirements for Microsoft WLP 3.10, and stricter performance requirements for future WLP
- Two stereo DAC support 16/20/24-bit PCM for two independent playback (multiple streaming)
- Two stereo ADC supports 16/20/24-bit PCM format for two independent recording
- All DACs support independent 44.1k/48k/96k/192kHz sample rate
- All ADCs support independent 44.1k/48k/96k/192kHz sample rate
- Two independent SPDIF outputs support 16/20/24-bit format and 44.1k/48k/88.2k/96k/192kHz rate
- All analog jack ports except MONO, BEEP-IN and HP-OUT are stereo input and output re-tasking
- Supports line level mono output
- Supports analog PCBEEP input, and features an integrated digital BEEP generator
- Support two stereo digital microphone input for microphone array AEC/BF application
- Each stereo digital microphone interface has its own clock output to support independent sample rate
- Supports legacy analog mixer architecture
- Built-in five headphone amplifiers on port-A and port-D, port-E, port-F and port-I.
- Headphone amplifier on port-I (HP-OUT) is designed to drive output without external DC blocking capacitors
- Software selectable 2.5V and 3.2V reference output for microphone bias
- Software selectable boost gain (+10/+20/+30dB) for analog microphone input
- Two jack detection pins; each supports detection of up to 4 jacks
- Supports two GPIO (General Purpose Input/Output) pins (pin sharing with digital microphone interface)
- Supports EAPD (External Amplifier Power Down) control for external amplifier
- Supports anti-pop mode when analog power AVDD is on and digital power is off
- Supports 1.5V~3.3V scalable I/O for HD Audio link
- 48-pin LQFP ‘Green’ package

- Jack detection function is supported when device is in power down mode (D3)
- Independent secondary SPDIF converter and pin to output digital stream to HDMI transmitter
- Intel low power ECR compliant, supports power status control for each analog converter and pin widgets, supports jack detection and wake up event in D3 mode

2.2. Software Features

- Meets Microsoft WLP 3.10 and future WLP audio requirements
- WaveRT-based audio function driver for Windows Vista
- EAX™ 1.0 & 2.0 compatible
- Direct Sound 3D™ compatible
- A3D™ compatible
- I3DL2 compatible
- Emulation of 26 sound environments to enhance gaming experience
- Multi-band software equalizer and related tools are provided
- Voice Cancellation and Key Shifting effect
- Dynamic range control (expander, compressor and limiter) with adjustable parameters
- Intuitive Configuration Panel (Realtek Audio Manager) to enhance user experience
- Provides 10-foot GUI for easy menu navigation on Windows Media Center
- Microphone Acoustic Echo Cancellation (AEC), Noise Suppression (NS), and Beam Forming (BF) technology for voice application
- Smart multiple streaming operation
- HDMI audio driver for AMD platform
- Dolby® PCEE program™ (optional software feature)
- DTS® CONNECT™ (optional software feature)
- SRS® TrueSurround HD (optional software feature)

- Fortemedia® SAM™ technology for voice processing (Beam Forming and Acoustic Echo Cancellation) (optional software feature)

3. System Applications

- Desktop and mobile PCs
- Ultra mobile devices

4. Block Diagram

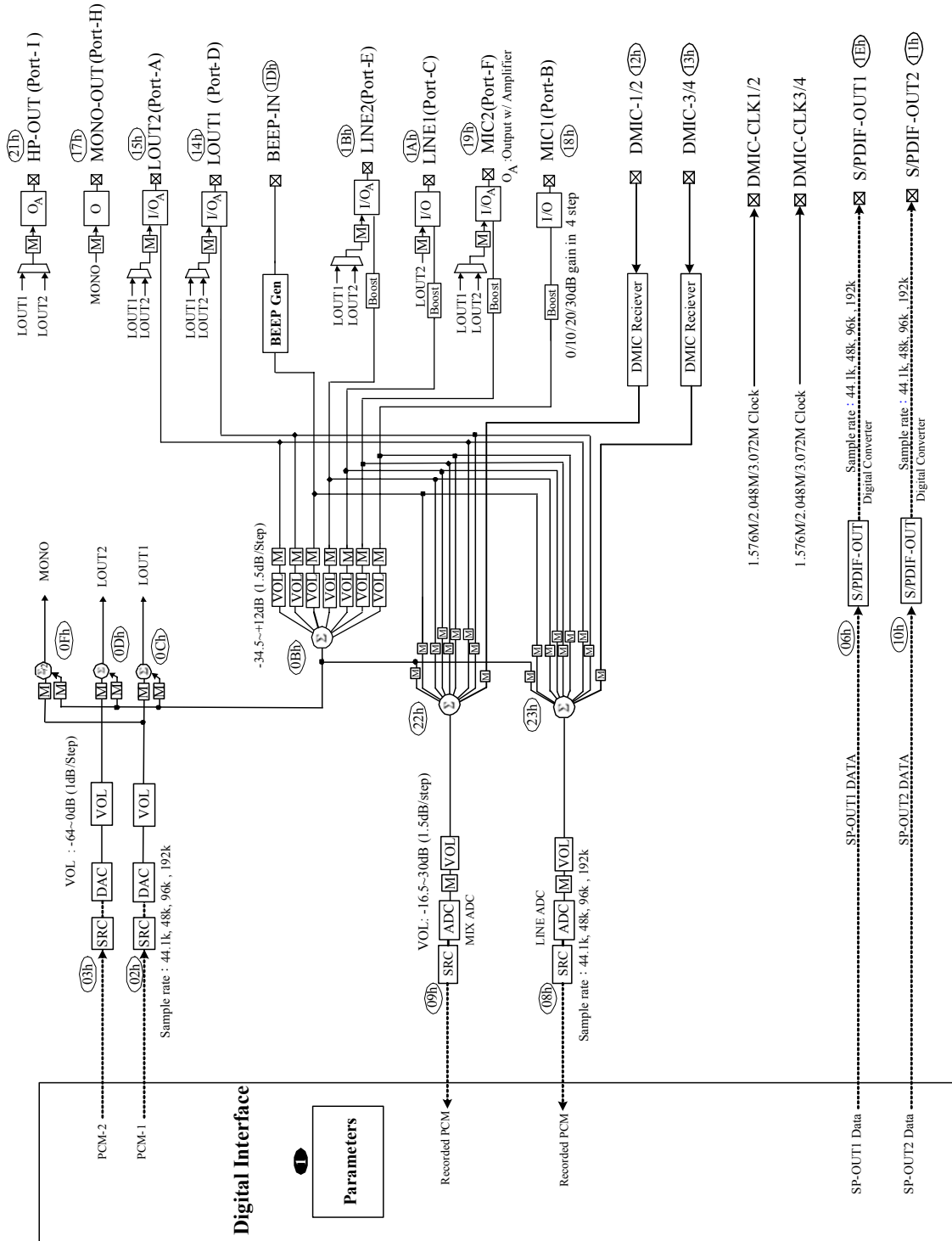

Figure 1. Block Diagram

5. Pin Assignments

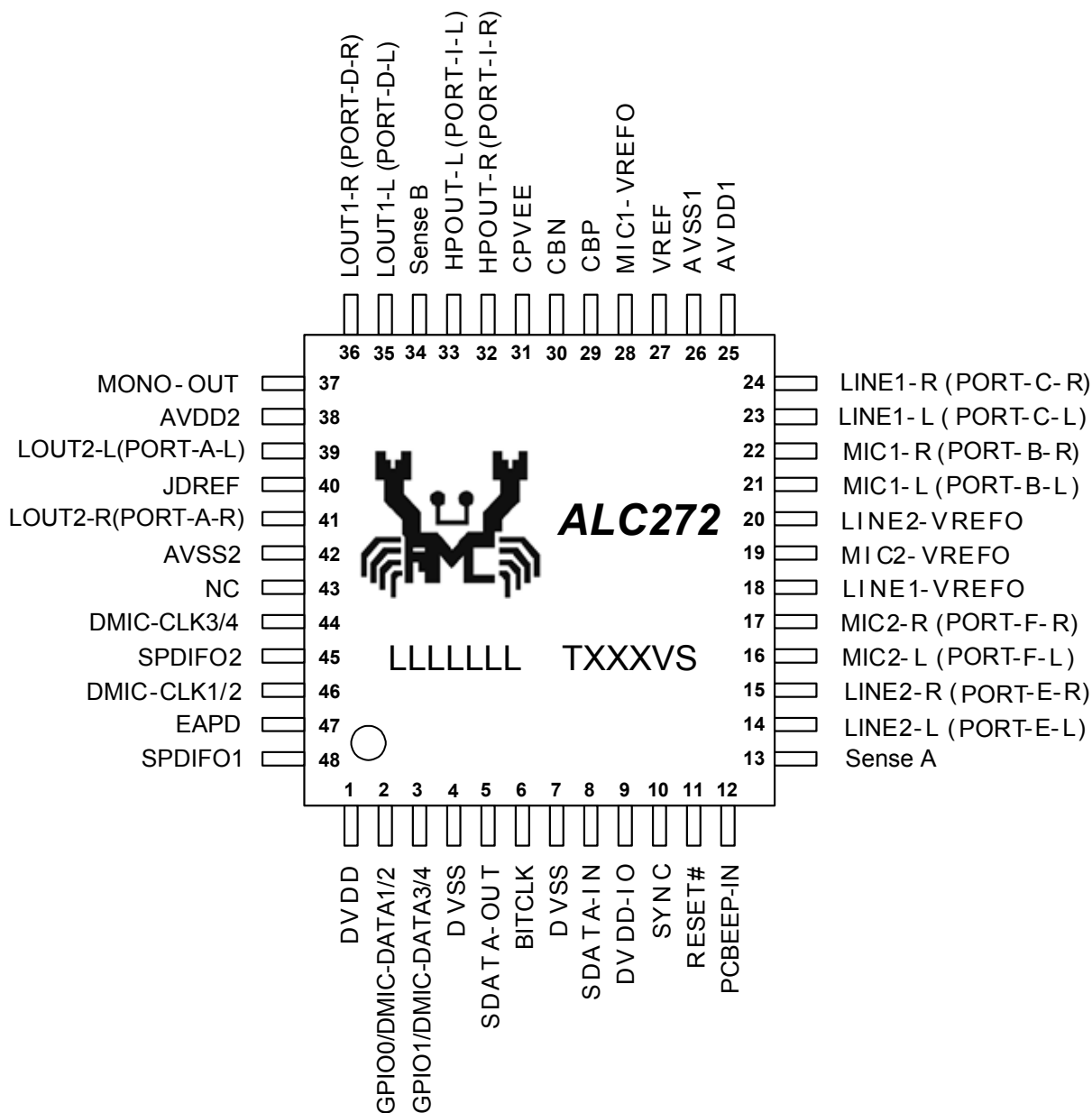

Figure 2. Pin Assignments

5.1. Package and Version Identification

Green package is indicated by a 'G' in the location marked 'T'. The silicon version and step numbers are shown in the location marked 'V' and 'S'.

6. Pin Descriptions

6.1. Digital I/O Pins

Table 1. Digital I/O Pins

| Name | Type | Pin | Description | Characteristic Definition |
|-------------------------|------|-----|---|---|
| RESET# | I | 11 | H/W Reset | $V_i=0.5*DVDDIO$ |
| SYNC | I | 10 | Sample Sync (48KHz) | $V_i=0.5*DVDDIO$ |
| BITCLK | I | 6 | 24MHz Bit Clock Input | $V_i=0.5*DVDDIO$ |
| SDATA-OUT | I | 5 | Serial TDM Data Input | $V_i=0.5*DVDDIO$ |
| SDATA-IN | O | 8 | Serial TDM Data Output | In: $V_i=0.5*DVDDIO$ Out: $V_{OH}=DVDDIO, V_{OL}=DVSS$ |
| GPIO0 / DMIC-DATA1/2 | IO | 2 | General Purpose Input/Output 0 / Data Input for Digital Mic1/2 | In: $V_i=0.5*DVDD$; Out: $V_{OH}=DVDD, V_{OL}=DVSS$ / Shared with the digital MIC input data. |
| GPIO1 / DMIC-DATA3/4 | IO | 3 | General Purpose Input/Output 1/ Data Input for Digital Mic3/4 | In: $V_i=0.5*DVDD$; Out: $V_{OH}=DVDD, V_{OL}=DVSS$ / Shared with the digital MIC input data. |
| EAPD | O | 47 | External Amplifier Power Down | $V_{OH}=DVDDIO, V_{OL}=DVSS$ |
| SPDIFO1 | O | 48 | SPDIF Output 1 | Output has 12 mA@75Ω driving capability. |
| SPDIFO2 | O | 45 | SPDIF Output 2 | Output has 12 mA@75Ω driving capability. |
| DMIC-CLK3/4 | O | 44 | Clock Output for Digital Mic3/4 | 3.072M / 1.536M / 2.048M Hz |
| DMIC-CLK1/2 | O | 46 | Clock Output for Digital Mic1/2 | 3.072M / 1.536M / 2.048M Hz |
| | | | | Total: 12 Pins |

6.2. Analog I/O Pins

Table 2. Analog I/O Pins

| Name | Type | Pin | Description | Characteristic Definition |
|-----------|------|-----|---|--|
| LINE2-L | IO | 14 | 2 nd Line Input Left Channel | Analog input/output, default is input (PORT-E-L) |
| LINE2-R | IO | 15 | 2 nd Line Input Right Channel | Analog input/output, default is input (PORT-E-R) |
| MIC2-L | IO | 16 | 2 nd Stereo Microphone Input Left Channel | Analog input/output, default is input (PORT-F-L) |
| MIC2-R | IO | 17 | 2 nd Stereo Microphone Input Right Channel | Analog input/output, default is input (PORT-F-R) |
| MIC1-L | IO | 21 | 1 st Stereo Microphone Input Left Channel | Analog input/output, default is input (PORT-B-L) |
| MIC1-R | IO | 22 | 1 st Stereo Microphone Input Right Channel | Analog input/output, default is input (PORT-B-R) |
| LINE1-L | IO | 23 | 1 st Line Input Left Channel | Analog input/output, default is input (PORT-C-L) |
| LINE1-R | IO | 24 | 1 st Line Input Right Channel | Analog input/output, default is input (PORT-C-R) |
| PCBEEP-IN | I | 12 | External PCBEEP Input | Analog input, 1.6Vrms of full-scale input |
| HPOUT-R | O | 32 | Headphone Out Right Channel | Analog output (PORT-I-R) |
| HPOUT-L | O | 33 | Headphone Out Left Channel | Analog output (PORT-I-L) |
| LOUT1-L | IO | 35 | LOUT1 Output Left Channel | Analog output (PORT-D-L) |
| LOUT1-R | IO | 36 | LOUT1 Output Right Channel | Analog output (PORT-D-R) |

| Name | Type | Pin | Description | Characteristic Definition |
|----------|------|-----|---------------------|--|
| MONO-OUT | O | 37 | MONO-OUT | Analog output (PORT-H) |
| LOUT2-L | IO | 39 | LOUT2 Left Channel | Analog output (PORT-A-L) |
| LOUT2-R | IO | 41 | LOUT2 Right Channel | Analog output (PORT-A-R) |
| Sense A | I | 13 | Jack Detect Pin 1 | Jack resistor network (5.1k, 10k, 20K, 39.2k) with 1% accuracy |
| Sense B | I | 34 | Jack Detect Pin 2 | Jack resistor network (5.1k, 10k, 20K, 39.2k) with 1% accuracy |
| | | | | Total: 18 Pins |

6.3. Filter/Reference/Not Connect

Table 3. Filter/Reference

| Name | Type | Pin | Description | Characteristic Definition |
|-------------|------|-----|---------------------------------------|--|
| VREF | - | 27 | 2.5V Reference Voltage | Typical 2.25V, 10 μ F capacitor to analog ground |
| LINE1-VREFO | O | 18 | Bias Voltage for MIC2 Jack | 2.5V/3.2V reference voltage |
| MIC2-VREFO | O | 19 | Bias Voltage for MIC2 Jack | 2.5V/3.2V reference voltage |
| LINE2-VREFO | O | 20 | Bias Voltage for LINE2 Jack | 2.5V/3.2V reference voltage |
| MIC1-VREFO | O | 28 | Bias Voltage for MIC1 Jack | 2.5V/3.2V reference voltage |
| CBP | - | 29 | Charge Pump Bucket Capacitor | 2.2 μ F capacitor to CBN (Positive terminal to CBP) |
| CBN | - | 30 | Charge Pump Bucket Capacitor | 2.2 μ F capacitor to CBP (Negative terminal to CBN) |
| CPVEE | - | 31 | Reference Voltage | 2.2 μ F capacitor to analog ground (negative terminal to CPVEE, positive to analog ground) |
| JDREF | - | 40 | Reference Resistor for Jack Detection | 20K, 1% resistor to analog ground |
| NC | - | 43 | Not Connect | |
| | | | | Total: 10 Pins |

6.4. Power/Ground

Table 4. Power/Ground

| Name | Type | Pin | Description | Characteristic Definition |
|---------|------|-----|-------------|--|
| AVDD1 | I | 25 | Analog VDD | Analog power for mixer and amplifier |
| AVSS1 | I | 26 | Analog GND | Analog ground for mixer and amplifier |
| AVDD2 | I | 38 | Analog VDD | Analog power for DACs and ADCs |
| AVSS2 | I | 42 | Analog GND | Analog ground for DACs and ADCs |
| DVDD | I | 1 | Digital VDD | Digital power for core |
| DVSS | I | 4 | Digital GND | Digital ground for core |
| DVDD-IO | I | 9 | Digital VDD | Digital power for HDA link (1.5V~3.3V) |
| DVSS | I | 7 | Digital GND | Digital ground for HDA link |
| | | | | Total: 8 Pins |

7. High Definition Audio Link Protocol

7.1. Link Signals

The High Definition Audio (HDA) Link is the digital serial interface that connects the HDA codecs to the HDA Controller. The HDA link protocol is controller synchronous, based on a 24.0MHz BIT-CLK sent by the HDA controller. The input and output streams, including command and PCM data, are isochronous with a 48kHz frame rate. Figure 3 shows the basic concept of the HDA link protocol.

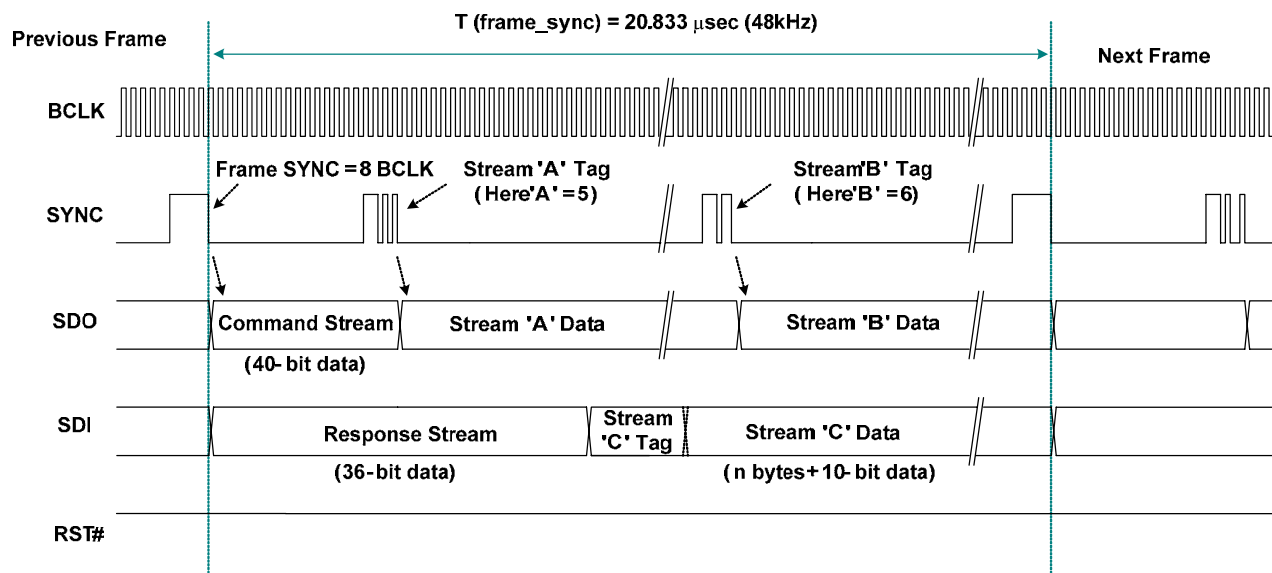

Figure 3. HDA Link Protocol

7.1.1. Signal Definitions

Table 5. Link RESET#

| Item | Description |
|--------|---|
| BCLK | 24.0MHz bit clock sourced from the HDA controller and connecting to all codecs. |
| SYNC | A 48kHz signal used to synchronize input and output streams on the link. It is sourced from the HDA controller and connects to all codecs. |
| SDO | Serial Data Output signal driven by the HDA controller to all codecs. Commands and data streams are carried on SDO. The data rate is double-pumped; the controller drives data onto the SDO, the codec samples data present on SDO with respect to each edge of BCLK. The HDA controller must support at least one SDO. To extend outbound bandwidth, multiple SDOs may be supported. |
| SDI | Serial Data Input signal driven by the codec. This is point-to-point serial data from the codec to the HDA controller. The controller must support at least one SDI. Up to a maximum of 15 SDI's can be supported. SDI is driven by the codec at each rising edge of BCLK, and sampled by the controller at each rising edge of BCLK. SDI can be driven by the controller to initialize the codec's ID. |
| RESET# | Active low reset signal. Asserted to reset the codec to default power-on state. RESET# is sourced from the HDA controller and connects to all codecs. |

Table 6. HDA Signal Definitions

| Signal Name | Source | Type for Controller | Description |
|-------------|------------------|---------------------|---|
| BCLK | Controller | Output | Global 24.0MHz bit clock. |
| SYNC | Controller | Output | Global 48kHz Frame Sync and outbound tag signal. |
| SDO | Controller | Output | Serial data output from controller. |
| SDI | Codec/Controller | Input/Output | Serial data input from codec. Weakly pulled down by the controller. |
| RESET# | Controller | Output | Global active low reset signal. |

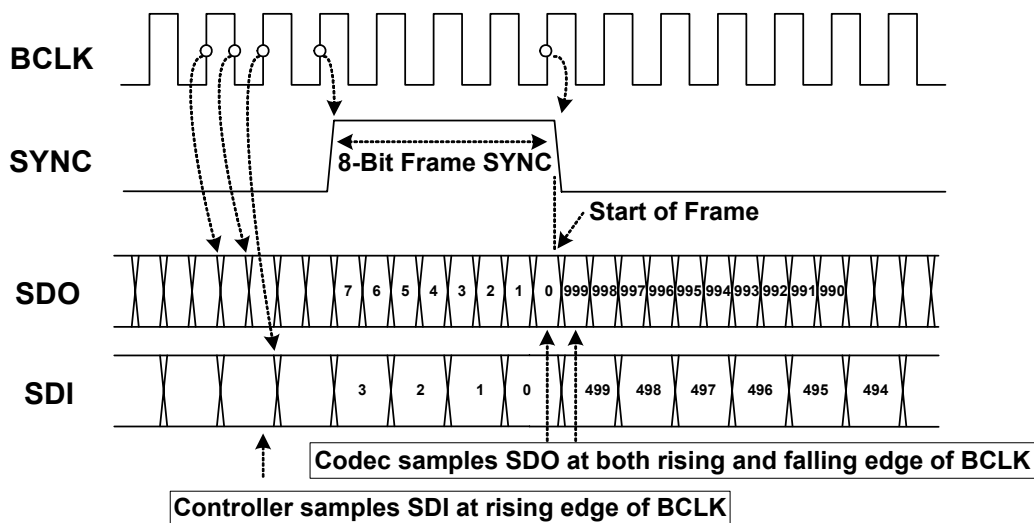
Figure 4. Bit Timing

7.1.2. Signaling Topology

The HDA controller supports two SDOs for the outbound stream, up to 15 SDIs for the inbound stream. RESET#, BCLK, SYNC, SDO0, and SDO1 are driven by the controller to codecs. Each codec drives its own point-to-point SDI signal(s) to the controller.

Figure 5 shows the possible connections between the HDA controller and codecs:

- Codec 0 is a basic connection. There is one single SDO and one single SDI for normal transmission
- Codec 1 has two SDOs for doubled outbound rate, and a single SDI for normal inbound rate
- Codec 3 supports a single SDO for normal outbound rate, and two SDIs for doubled inbound rate
- Codec N has two SDOs and multiple SDIs

The multiple SDOs and multiple SDIs are used to expand the transmission rate between controller and codecs. Section 7.2 Frame Composition, page 12, describes the detailed outbound and inbound stream compositions for single and multiple SDOs/SDIs.

The connections shown in Figure 5 can be implemented concurrently in an HDA system. The ALC272 is designed to receive a single SDO stream.

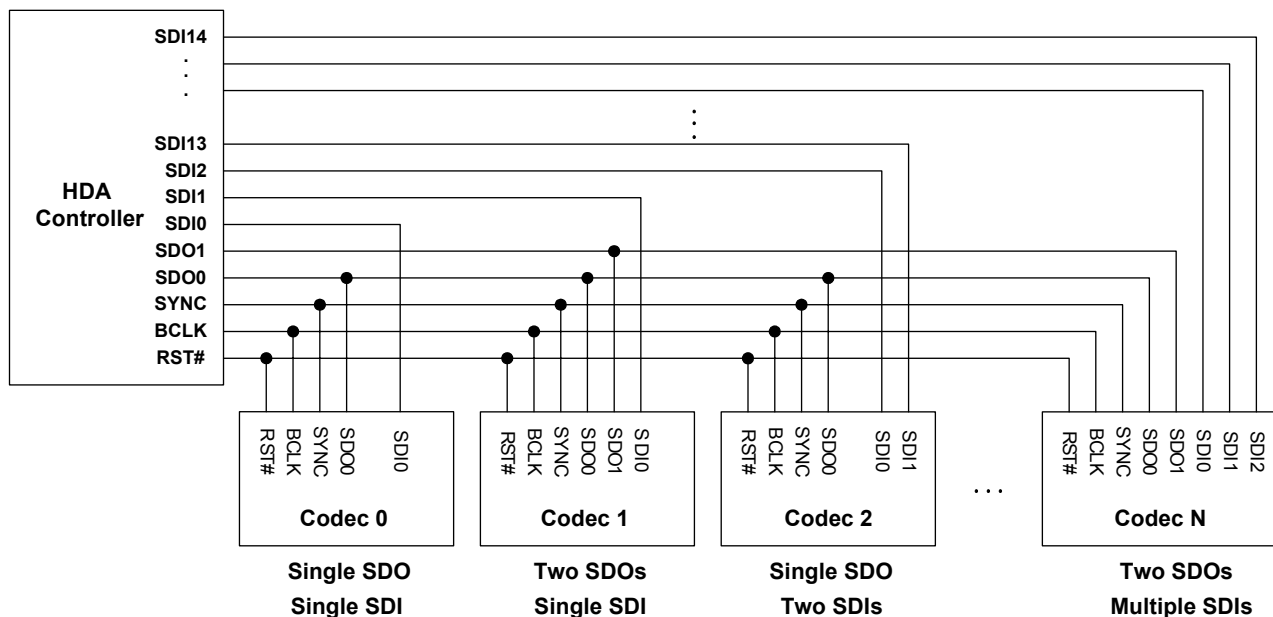

Figure 5. Signaling Topology

7.2. Frame Composition

7.2.1. Outbound Frame – Single SDO

An outbound frame is composed of one 32-bit command stream and multiple data streams. There are one or multiple sample blocks in a data stream. Only one sample block exists in a stream if the HDA controller delivers a 48kHz rate of samples to the codec. Multiple sample blocks in a stream means the sample rate is a multiple of 48kHz. This means there should be 2 blocks in the same stream to carry 96kHz samples (Figure 6).

For outbound frames, the stream tag is not in SDO, but in the SYNC signal. A new data stream is started at the end of the stream tag. The stream tag includes a 4-bit preamble and 4-bit stream ID (Figure 7).

To keep the cadence of converters bound to the same stream, samples for these converters must be placed in the same block.

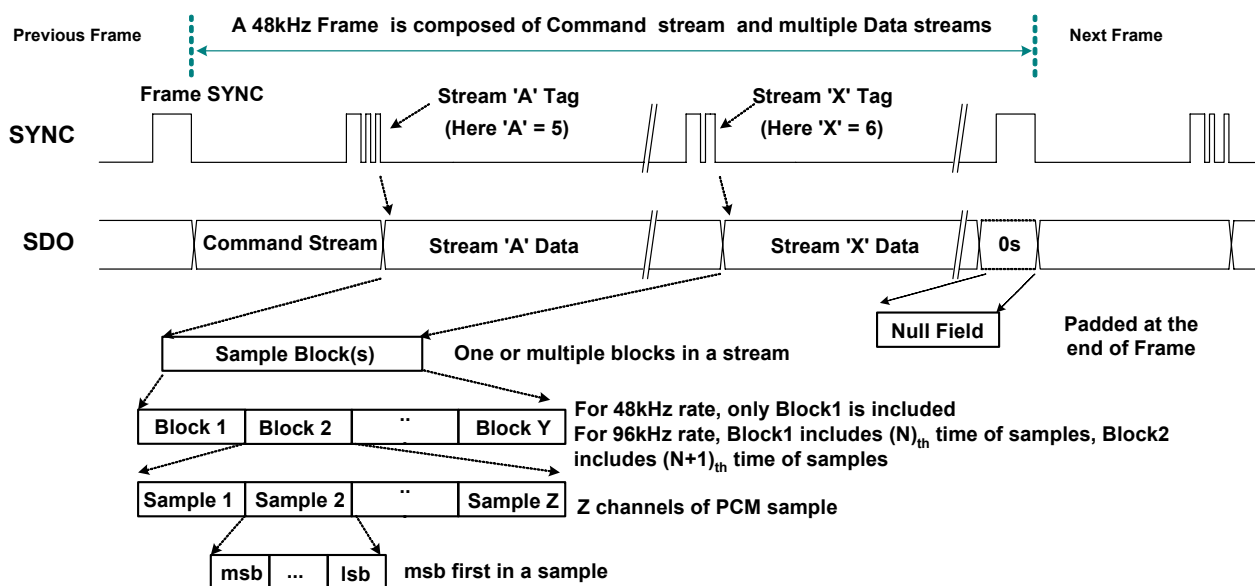

Figure 6. SDO Outbound Frame

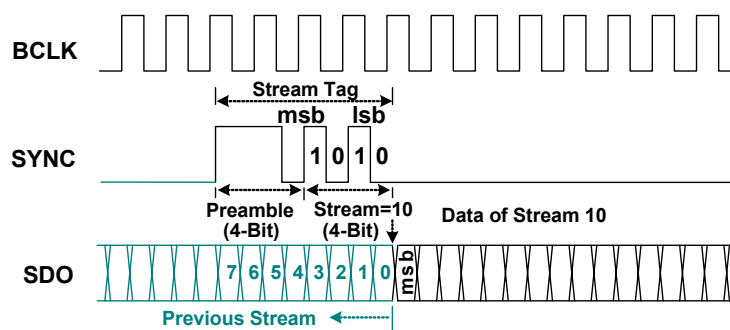

Figure 7. SDO Stream Tag is Indicated in SYNC

7.2.2. Outbound Frame – Multiple SDOs

The HDA controller allows two SDO signals to be used to stripe outbound data, completing transmission in less time to get more bandwidth. If software determines that the target codec supports multiple SDO capability, it enables the ‘Stripe Control’ bit in the controller’s Output Stream Control Register to initiate a specific stream (Stream ‘A’ in Figure 8) to be transmitted on multiple SDOs. In this case, the MSB of stream data is always carried on SDO0, the second bit on SDO1 and so forth.

SDO1 is for transmitting a striped stream. The codec does not support multiple SDOs connected to SDO0.

To guarantee all codecs can determine their corresponding stream, the command stream is not striped. It is always transmitted on SDO0, and copied on SDO1.

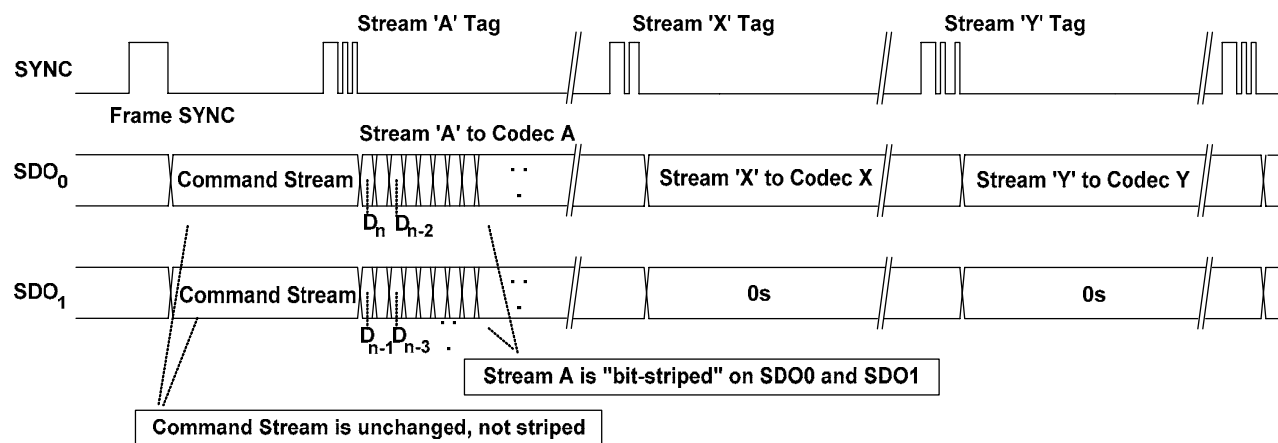

Figure 8. Striped Stream on Multiple SDOs

7.2.3. Inbound Frame – Single SDI

An Inbound Frame – Single SDI is composed of one 36-bit response stream and multiple data streams. Except for the initialization sequence (turnaround and address frame), SDI is driven by the codec at each rising edge of BCLK. The controller also samples data at the rising edge of BCLK (Figure 9).

The SDI stream tag is not carried by SYNC, but included in the SDI. A complete SDI data stream includes one 4-bit stream tag, one 6-bit data length, and n-bit sample blocks. Zeros will be padded if the total length of the contiguous sample blocks within a given stream is not of integral byte length (Figure 10).

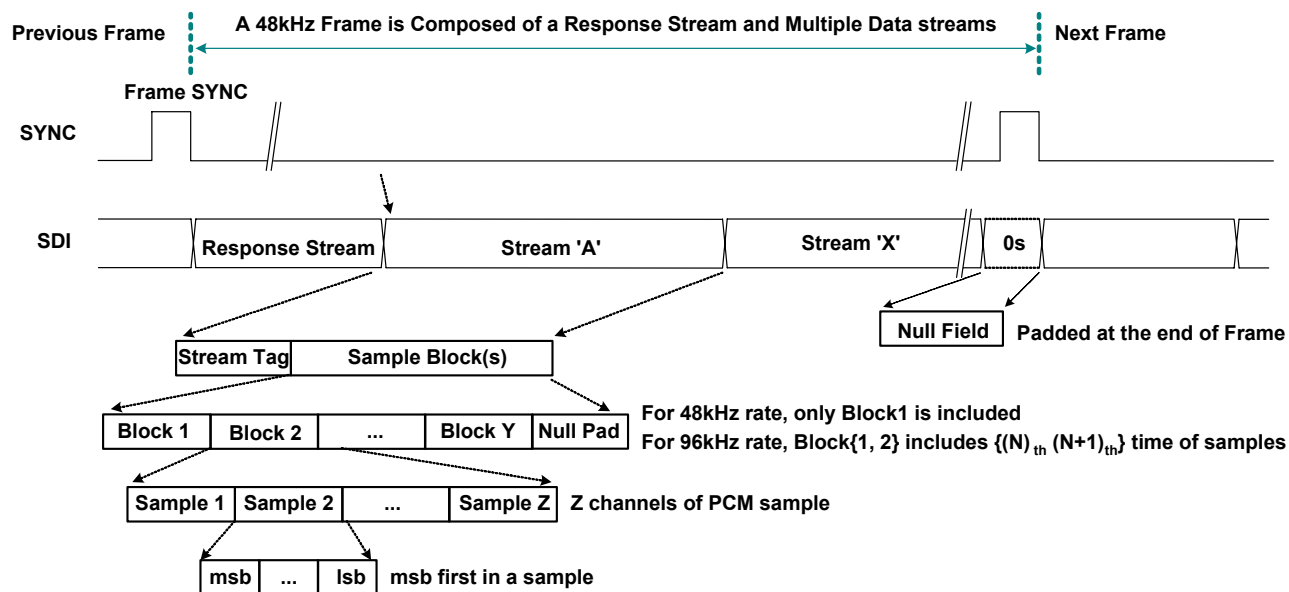

Figure 9. SDI Inbound Stream

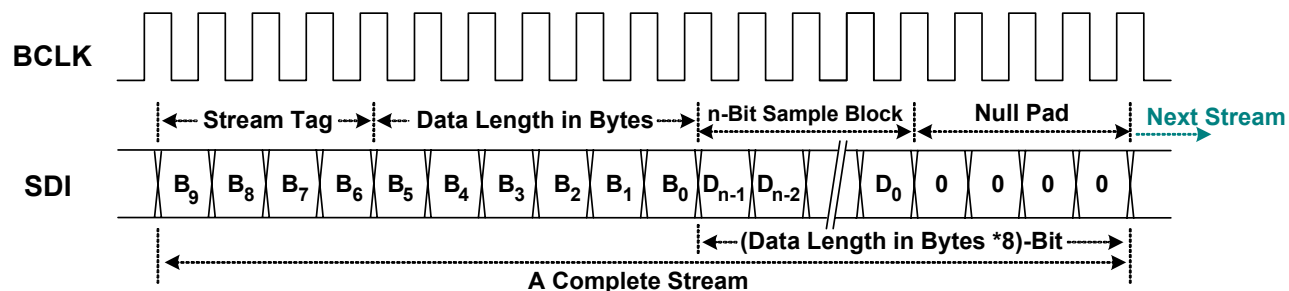

Figure 10. SDI Stream Tag and Data

7.2.4. Inbound Frame – Multiple SDIs

A codec can deliver data to the controller on multiple SDIs to achieve higher bandwidth. If an inbound stream exceeds the data transfer limits of a single SDI, the codec can divide the data onto separate SDI signals, each of which operate independently, with different stream numbers at the same frame time. This is similar to having multiple codecs connected to the controller. The controller samples the divided stream into separate memory with multiple DMA descriptors, then software re-combines the divided data into a meaningful stream.

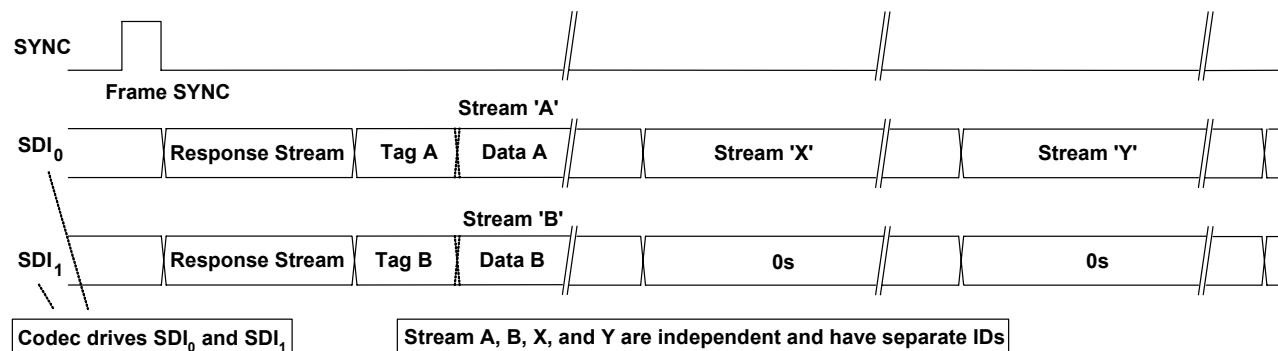

Figure 11. Codec Transmits Data Over Multiple SDIs

7.2.5. Variable Sample Rates

The HDA link is designed for sample rates of 48kHz. Variable sample rates are delivered in multiple or sub-multiple rates of 48kHz. Two sample blocks per frame result in a 96kHz delivery rate, one sample block over two frames results in a 24kHz delivery rate. The HDA specification states that the sample rate of the outbound stream be synchronized by the controller, not by the codec. Each stream has its own sample rate, independent of any other stream.

The HDA controller supports 48kHz and 44.1kHz base rates. Table 7, page 16, shows the recommended sample rates based on multiples or sub-multiples of one of the two base rates.

Rates in sub-multiples (1/n) of 48kHz are interleaving n frames containing no sample blocks. Rates in multiples (n) of 48kHz contain n sample blocks in a frame. Table 8, page 16, shows the delivery cadence of variable rates based on 48kHz.

The HDA link is defined to operate at a fixed 48kHz frame rate. To deliver samples in (sub) multiple rates of 44.1kHz, an appropriate ratio between 44.1kHz and 48kHz must be maintained to avoid frequency drift. The appropriate ratio between 44.1kHz and 48kHz is 147/160. Meaning 147 sample blocks are transmitted every 160 frames.

The cadence '12-11-11-12-11-11-12-11-11-12-11-11-11- (repeat)' interleaves 13 frames containing no sample blocks in every 160 frames. It provides a low long-term frequency drift for 44.1kHz of delivery rate. Rates in sub-multiples (1/n) of 44.1kHz also follow this cadence *and* interleave n empty frames. Rates in multiples (n) of 44.1kHz applying this cadence contain n sample blocks in the non-empty frame AND interleave an empty frame between non-empty frames (Table 9 , page 17).

Table 7. Defined Sample Rate and Transmission Rate

| (Sub) Multiple | 48kHz Base | 44.1kHz Base |
|----------------|--|---|
| 1/6 | 8kHz (1 sample block every 6 frames) | - |
| 1/4 | 12kHz (1 sample block every 4 frames) | 11.025kHz (1 sample block every 4 frames) |
| 1/3 | 16kHz (1 sample block every 3 frames) | - |
| 1/2 | - | 22.05kHz (1 sample block every 2 frames) |
| 2/3 | 32kHz (2 sample blocks every 3 frames) | - |
| 1 | 48kHz (1 sample block per frame) | 44.1kHz (1 sample block per frame) |
| 2 | 96kHz (2 sample blocks per frame) | 88.2kHz (2 sample blocks per frame) |
| 4 | 192kHz (4 sample blocks per frame) | 176.4kHz (4 sample blocks per frame) |

Table 8. 48kHz Variable Rate of Delivery Timing

| Rate | Delivery Cadence | Description |
|--------|----------------------------|---|
| 8kHz | YNNNNN (repeat) | One sample block is transmitted in every 6 frames |
| 12kHz | YNNN (repeat) | One sample block is transmitted in every 4 frames |
| 16kHz | YNN (repeat) | One sample block is transmitted in every 3 frames |
| 32kHz | Y ² NN (repeat) | One sample block is transmitted in every 6 frames |
| 48kHz | Y (repeat) | One sample block is transmitted in each frames |
| 96kHz | Y ² (repeat) | Two sample blocks are transmitted in each frame |
| 192kHz | Y ⁴ (repeat) | Four sample blocks are transmitted in each frame |

N: No sample block in a frame

Y: One sample block in a frame

Yx: X sample blocks in a frame

Table 9. 44.1kHz Variable Rate of Delivery Timing

| Rate | Delivery Cadence |
|-------------|---|
| 11.025kHz | {12}{-}{11}{-}{11}{-}{12}{-}{11}{-}{11}{-}{12}{-}{11}{-}{11}{-}{12}{-}{11}{-}{11}{-}{11}{-} (repeat) |
| 22.05kHz | {12}{-}{11}{-}{11}{-}{12}{-}{11}{-}{11}{-}{12}{-}{11}{-}{11}{-}{12}{-}{11}{-}{11}{-}{11}{-} (repeat) |
| 44.1kHz | 12-11-11-12-11-11-12-11-11-12-11-11-11- (repeat) |
| 88.2kHz | 12 ² -11 ² -11 ² -12 ² -11 ² -11 ² -12 ² -11 ² -11 ² -12 ² -11 ² -11 ² - (repeat) |
| 174.4kHz | 12 ⁴ -11 ⁴ -11 ⁴ -12 ⁴ -11 ⁴ -11 ⁴ -12 ⁴ -11 ⁴ -11 ⁴ -12 ⁴ -11 ⁴ -11 ⁴ - (repeat) |

11.025kHz: {12}=YNNNYNNNYNNNYNNNYNNNYNNNYNNNYNNNYNNNYNNNYNNNYNNNYNN
{11}=YNNNYNNNYNNNYNNNYNNNYNNNYNNNYNNNYNNNYNNNYNNNYNNNYNN
{ - }=NNNN

22.050kHz: {12}=YNY
{11}=YNY
{ - }=NN

- 44.1kHz 12- =Contiguous 12 frames containing 1 sample blocks each, followed by one frame with no sample block.
- 88.2kHz 12²- =Contiguous 12 frames containing 2 sample blocks each, followed by one frame with no sample block.
- 174.4kHz 12⁴- =Contiguous 12 frames containing 4 sample blocks each, followed by one frame with no sample block.

7.3. Reset and Initialization

There are two types of reset within an HDA link:

- Link Reset
Generated by assertion of the RESET# signal. All codecs return to their power-on state
- Codec Reset
Generated by software directing a command to reset a specific codec back to its default state

An initialization sequence is requested after any of the following three events:

- Link Reset
- Codec Reset
- Codec changes its power state, e.g., hot docking a codec to an HDA system

7.3.1. Link Reset

A link reset may be caused by any of the following three events:

1. The HDA controller asserts RESET# for any reason (power up, or PCI reset)
2. Software initiates a link reset via the 'CRST' bit in the Global Control Register (GCR) of the HDA controller
3. Software initiates power management sequences. Figure 12, page 19, shows the 'Link Reset' timing including the 'Enter' sequence (❶~❺) and 'Exit' sequence (❻~❾)

Enter 'Link Reset':

- ❶ Software writes a 0 to the 'CRST' bit in the Global Control Register of the HDA controller to initiate a link reset
- ❷ As the controller completes the current frame, it does not signal the normal 8-bit frame SYNC at the end of the frame
- ❸ The controller drives SYNC and all SDOs to low. Codecs also drive SDIs to low
- ❹ The controller asserts the RESET# signal to low, and enters the 'Link Reset' state
- ❺ All link signals driven by controller and codecs should be tri-state by internal pull-low resistors

Exit from ‘Link Reset’:

- ⑥ If BCLK is re-started for any reason (codec, wake-up event, power management, etc.)
- ⑦ Software is responsible for de-asserting RESET# after a minimum of 100 μ s BCLK running time (the 100 μ sec provides time for the codec PLL to stabilize)
- ⑧ Minimum of 4 BCLKs after RESET# is de-asserted, the controller starts to signal normal frame SYNC
- ⑨ The codec drives its SDI to request an initialization sequence (when the SDI is driven high at the last bit of frame SYNC)

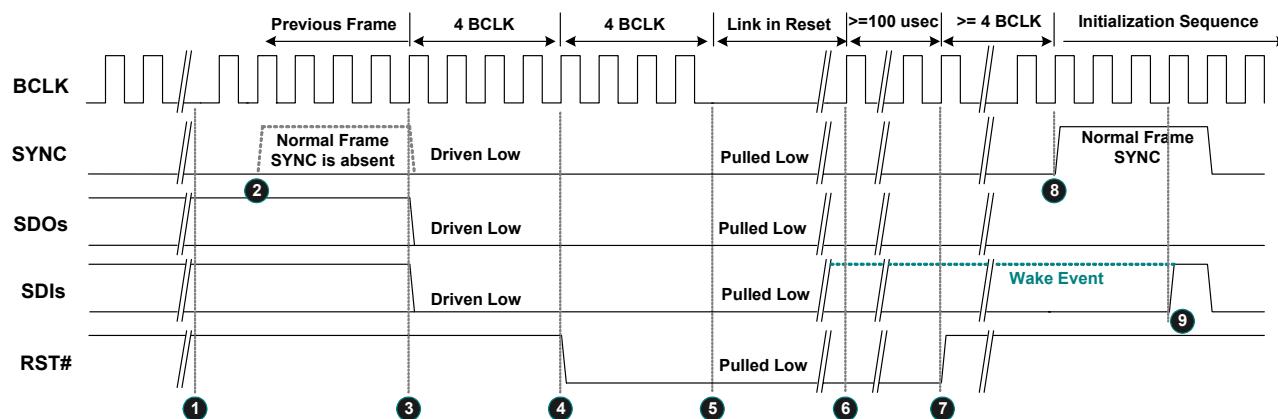

Figure 12. Link Reset Timing

7.3.2. Codec Reset

A ‘Codec Reset’ is initiated via the Codec RESET command verb. It results in the target codec being reset to the default state. After the target codec completes its reset operation, an initialization sequence is requested.

In the ALC272, the extend power state of conforming to Intel low power ECR the function reset could not initialize the register setting. Host SW needs to send “two” function reset consecutively to reset all settings.

7.3.3. Codec Initialization Sequence

- ❶ The codec drives SDI high at the last bit of SYNC to request a Codec Address (CAD) from the controller
- ❷ The codec stops driving the SDI during this turnaround period
- ❸❹❺❻ The controller drives SDI to assign a CAD to the codec
- ❼ The controller releases the SDI after the CAD has been assigned
- ❽ Normal operating state

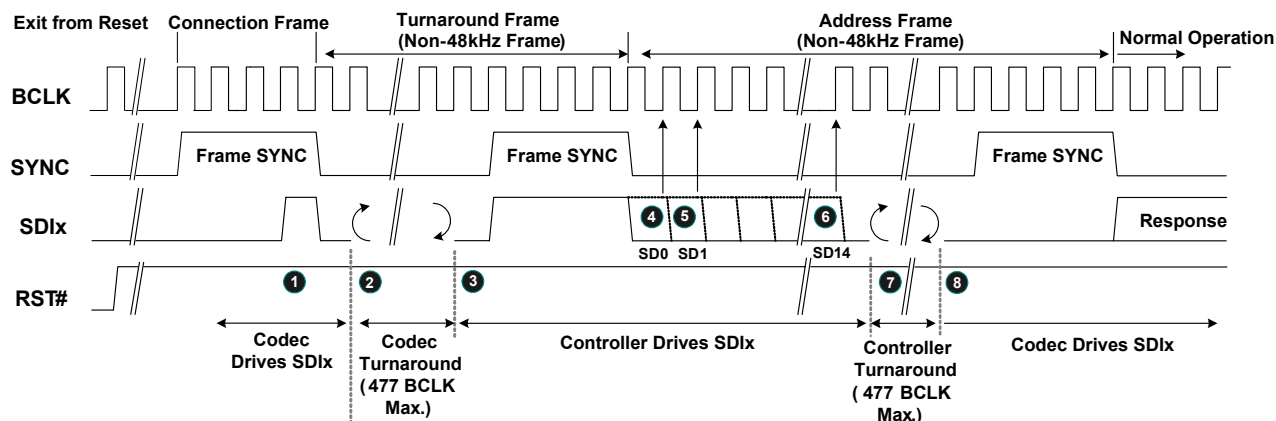

Figure 13. Codec Initialization Sequence

7.4. Verb and Response Format

7.4.1. Command Verb Format

There are two types of verbs: one with 4-bit identifiers (4-bit verbs) and 16-bits of data, the other with 12-bit identifiers (12-bit verbs) and 8-bits of data. Table 10 shows the 4-bit verb structure of a command stream sent from the controller to operate the codec. Table 11 is the 12-bit verb structure that gets and controls parameters in the codec.

Table 10. 40-Bit Commands in 4-Bit Verb Format

| Bit [39:32] | Bit [31:28] | Bit [27:20] | Bit [19:16] | Bit [15:0] |
|-------------|---------------|-------------|-------------|------------|
| Reserved | Codec Address | Node ID | Verb ID | Payload |

Table 11. 40-Bit Commands in 12-Bit Verb Format

| Bit [39:32] | Bit [31:28] | Bit [27:20] | Bit [19:8] | Bit [7:0] |
|-------------|---------------|-------------|------------|-----------|
| Reserved | Codec Address | Node ID | Verb ID | Payload |

Table 12. Supported Commands

| Supported Verb | Get Verb | Set Verb | Root Node | Audio Function Group | Modem Function Group ^{*1} | HDMI Function Group ^{*1} | Vendor Define Group ^{*1} | Audio Out Converter | Audio In Converter | Pin Widget | Sum Widget | Selector Widget | Power Widget ^{*1} | Volume Knob | Beep Generator | Vendor Defined Widget |
|---------------------------|----------|----------|-----------|----------------------|------------------------------------|-----------------------------------|-----------------------------------|---------------------|--------------------|------------|------------|-----------------|----------------------------|-------------|----------------|-----------------------|
| Get parameter | F00 | - | Y | Y | - | - | - | Y | Y | Y | Y | Y | Y | Y | Y | Y |
| Connection Select | F01 | 701 | - | - | - | - | - | - | Y | Y | - | Y | - | - | - | - |
| Get Connection List Entry | F02 | - | - | - | - | - | - | - | Y | Y | Y | Y | - | - | - | - |
| Processing State | F03 | 703 | - | - | - | - | - | - | - | - | - | - | - | - | - | - |
| Coefficient Index | D-- | 5-- | - | - | - | - | - | - | - | - | - | - | - | - | - | Y |
| Processing Coefficient | C-- | 4-- | - | - | - | - | - | - | - | - | - | - | - | - | - | Y |
| Amplifier Gain/Mute | B-- | 3-- | - | - | - | - | - | - | Y | Y | Y | - | - | - | - | - |
| Stream Format | A-- | 2-- | - | - | - | - | - | Y | Y | - | - | - | - | - | - | - |
| Digital Converter 1 | F0D | 70D | - | - | - | - | - | Y | Y | - | - | - | - | - | - | - |
| Digital Converter 2 | F0D | 70E | - | - | - | - | - | Y | Y | - | - | - | - | - | - | - |
| Power State | F05 | 705 | - | Y | - | - | - | Y | Y | Y | - | - | - | - | - | - |
| Channel / Stream ID | F06 | 706 | - | - | - | - | - | Y | Y | - | - | - | - | - | - | - |
| SDI Select | F04 | 704 | - | - | - | - | - | - | - | - | - | - | - | - | - | - |
| Pin Widget Control | F07 | 707 | - | - | - | - | - | - | - | Y | - | - | - | - | - | - |
| Unsolicited Enable | F08 | 708 | - | - | - | - | - | - | - | Y | - | - | - | Y | - | - |
| Pin Sense | F09 | 709 | - | - | - | - | - | - | - | Y | - | - | - | - | - | - |
| EAPD Control | F0C | 70C | - | - | - | - | - | - | - | Y | - | - | - | - | - | - |
| All GPIO Control | F10-F1A | 710-71A | - | Y | - | - | - | - | - | - | - | - | - | - | - | - |
| Beep Generator Control | F0A | 70A | - | - | - | - | - | - | - | - | - | - | - | - | Y | - |
| Volume Knob Control | F0F | 70F | - | - | - | - | - | - | - | - | - | - | - | - | - | - |
| Subsystem ID, Byte 0 | F20 | 720 | - | Y | - | - | - | - | - | - | - | - | - | - | - | - |
| Subsystem ID, Byte 1 | F20 | 721 | - | Y | - | - | - | - | - | - | - | - | - | - | - | - |
| Subsystem ID, Byte 2 | F20 | 722 | - | Y | - | - | - | - | - | - | - | - | - | - | - | - |
| Subsystem ID, Byte 3 | F20 | 723 | - | Y | - | - | - | - | - | - | - | - | - | - | - | - |
| Config Default, Byte 0 | F1C | 71C | - | - | - | - | - | - | - | Y | - | - | - | - | - | - |
| Config Default, Byte 1 | F1C | 71D | - | - | - | - | - | - | - | Y | - | - | - | - | - | - |
| Config Default, Byte 2 | F1C | 71E | - | - | - | - | - | - | - | Y | - | - | - | - | - | - |
| Config Default, Byte 3 | F1C | 71F | - | - | - | - | - | - | - | Y | - | - | - | - | - | - |
| RESET | - | 7FF | - | Y | - | - | - | - | - | - | - | - | - | - | - | - |

*1: The ALC272 does not support Modem/HDMI/Vendor groups and Power State widgets.

Table 13. Supported Parameters

| Supported Parameter | Parameter ID | Root Node | Audio Function Group | Modem Function Group ^{*1} | HDMI Function Group ^{*1} | Vendor Define Group ^{*1} | Audio Out Converter | Audio In Converter | Pin Widget | Sum Widget | Selector Widget | Power Widget ^{*1} | Volume Knob | Beep Generator | Vendor Defined Widget |
|-----------------------------------|--------------|-----------|----------------------|------------------------------------|-----------------------------------|-----------------------------------|---------------------|--------------------|------------|------------|-----------------|----------------------------|-------------|----------------|-----------------------|
| Vendor ID | 00 | Y | - | - | - | - | - | - | - | - | - | - | - | - | - |
| Revision ID | 02 | Y | - | - | - | - | - | - | - | - | - | - | - | - | - |
| Subordinate Node Count | 04 | Y | Y | - | - | - | - | - | - | - | - | - | - | - | - |
| Function Group Type | 05 | - | Y | - | - | - | - | - | - | - | - | - | - | - | - |
| Audio Function Group Capabilities | 08 | - | Y | - | - | - | - | - | - | - | - | - | - | - | - |
| Audio Widget Capabilities | 09 | - | - | - | - | - | Y | Y | Y | Y | Y | Y | Y | Y | Y |
| Sample Size, Rate | 0A | - | Y | - | - | - | Y | Y | - | - | - | - | - | - | - |
| Stream Formats | 0B | - | Y | - | - | - | Y | Y | - | - | - | - | - | - | - |
| Pin Capabilities | 0C | - | - | - | - | - | - | - | Y | - | - | - | - | - | - |
| Input Amp Capabilities | 0D | - | - | - | - | - | - | Y | - | Y | Y | - | - | - | - |
| Output Amp Capabilities | 12 | - | - | - | - | - | - | - | Y | Y | - | - | - | - | - |
| Connection List Length | 0E | - | - | - | - | - | - | Y | Y | Y | Y | - | - | - | - |
| Supported Power States | 0F | - | Y | - | - | - | Y | Y | Y | Y | Y | - | - | - | Y |
| Processing Capabilities | 10 | - | - | - | - | - | - | - | - | - | - | - | - | - | Y |
| GPI/O Count | 11 | - | - | - | - | - | - | - | - | - | - | - | - | - | - |
| Volume Knob Capabilities | 13 | - | - | - | - | - | - | - | - | - | - | - | - | - | - |

^{*1}: The ALC272 does not support Modem/HDMI/Vendor groups and Power State widgets.

7.4.2. Response Format

There are two types of response from the codec to the controller. Solicited Responses are returned by the codec in response to a current command verb. The codec will send Solicited Response data in the next frame, without regard to the Set (Write) or Get (Read) command. The 32-bit response is interpreted by software, opaque to the controller.

Unsolicited Responses are sent by the codec independently of software requests. Jack Detection or GPI status information can be actively delivered to the controller and interpreted by software. The ‘Tag’ in Bit[31:28] is used to identify unsolicited events. This tag is undefined in the HDA specifications.

Table 14. Solicited Response Format

| Bit [35] | Bit [34] | Bit [33:32] | Bit [31:0] |
|----------|----------|-------------|------------|
| Valid | Unsol=0 | Reserved | Response |

Table 15. Unsolicited Response Format

| Bit [35] | Bit [34] | Bit [33:32] | Bit [31:28] | Bit [27:0] |
|----------|----------|-------------|-------------|------------|
| Valid | Unsol=1 | Reserved | Tag | Response |

7.4.3. Double Function Reset

This new reset is created by sending two Function Group resets back to back. This Function Group ‘Double’ reset shall do a full initialization and reset all settings to their power on defaults. A Double reset is defined as two Function Group Reset verbs received without any other intervening valid verbs. The reset verbs are not required to be received in sequential frames, but there must not be any other verbs received in frames between the receipt of the Function Group Reset verbs. It is allowed that there are several null commands received in frames between Function Group Reset verbs.

7.5. Power Management

The ALC272 is designed to meet Intel's low-power-state white paper and is ECR HDA-015B compliant. It meets the five attributes discussed in the white paper:

1. D3 state power < 30mW (without PC-Beep pass-through Function, with PC-Beep pass-through Function, the criteria is 60mW).
2. Exit latency (D3 to D0 transfer) < 10ms.
3. Audio pop/click suppression during D3 and D0 transition < -65dBV.
4. Supports Jack detection in D3 state.
5. D3 functions with or without the BITCLK

The ALC272 minimizes D3 state idle mode power consumption and increases overall battery life in mobile systems.

In D3 mode, only a power on reset or a 'double function reset' resets all ALC272 settings, cutting software configuration time spent entering/leaving D3 state, and reducing latency time for D3 to D0 transitions.

The ALC272 supports Wake-Up events in D3 mode, including jack detection and GPIO status changes. If the HDA-Link was alive (with BCLK), the ALC272 Wake-Up response is as normal. If no BITCLK is present, the ALC272 drives the SDI high in order to wake up the system

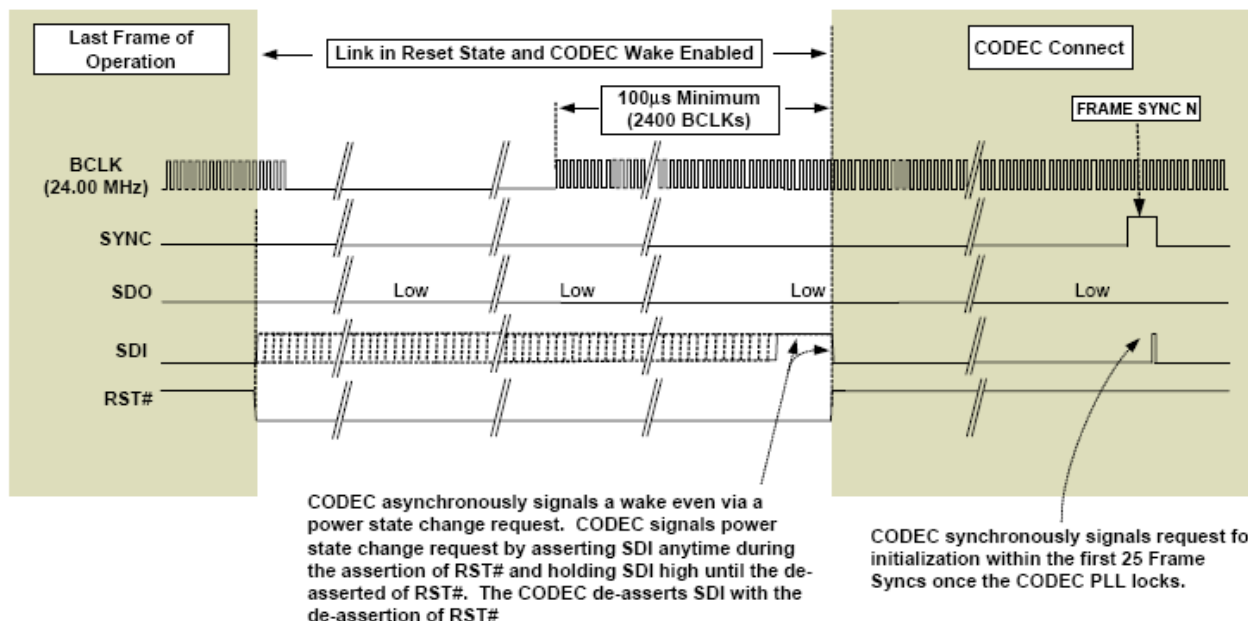

Figure 14. Resume From External Event (Wake-Up Event)

All power management state changes in widgets are driven by software. Table 16 shows the System Power State Definitions.

In the ALC272, all the widgets, including output/input converters, support power control. Software may have various power states depending on system configuration. Table 17 indicates those nodes that support power management. To simplify power control, software can configure whole codec power states through the audio function (NID=01h). Output converters (DACs) and input converters (ADCs) have no individual power control to supply fine-grained power control.

Table 16. System Power State Definitions

| Power States | Definitions |
|----------------|--|
| D0 | All power on. Individual DACs and ADCs can be powered up or down as required. |
| D1 | All amplifiers and converters (DACs and ADCs) are powered down. State maintained, analog reference stays up. |
| D2 | All amplifiers and converters (DACs and ADCs) are powered down. State maintained, but analog reference is off (D1 + analog reference off). |
| D3 | Power still supplied. The codec stops the internal clock. State is maintained. |
| D3 (No BitCLK) | Power still supplied, BITCLK stopped, and Reset in low state. |

Table 17. Power Controls in NID 01h

| Description | | D0 | D1 | D2 | D3 | D3 (No bclk) | Link Reset |
|--------------------------|-----------------------|--------|--------|--------|----|--------------|------------|
| Audio Function (NID=01h) | LINK Response | Normal | Normal | Normal | PD | PD | PD |
| | DACs | Normal | PD | PD | PD | PD | PD |
| | ADCs | Normal | PD | PD | PD | PD | PD |
| | All Headphone Drivers | Normal | Normal | PD | PD | PD | Normal |
| | All Mixers | Normal | Normal | PD | PD | PD | Normal |
| | All Reference | Normal | Normal | PD | PD | PD | Normal |

Table 18. Powered Down Conditions

| Condition | Description |
|-------------------------------|---|
| LINK Response powered down | Internal clock is stopped. SDATA-IN and SPDIF-OUT are floated with pulled low 47K resistors internally. SPDIF-IN is also floated. Detection of 'Link Reset Entry' and 'Link Reset Exit' sequences are supported. All states are maintained if DVDD is supplied. |
| DACs powered down | Analog block and digital filter are powered down. |
| ADCs powered down | Analog block and digital filter are powered down. Data on SDATA-IN is quiet. |
| Headphone Driver powered down | All headphone drivers are powered down. |
| Mixers powered down | All internal mixer widgets are powered down. The DC reference and VREFOUTx at individual pin complexes are still alive. |
| Reference power down | All internal references, DC reference, and VREFOUTx at individual pin complexes are off. |

8. Supported Verbs and Parameters

This section describes the Verbs and Parameters supported by various widgets in the ALC272. If a verb is not supported by the addressed widget, it will respond with 32 bits of '0'.

8.1. Verb – Get Parameters (Verb ID=F00h)

The 'Get Parameters' verb is used to get system information and the function capabilities of the HDA codec. All the parameters are read-only. There are a total of 15 ID parameters defined for each widget. Some parameters are supported only in a specific widget. Refer to section 7.4.1 Command Verb Format, page 20, to get detailed information about supported parameters.

Table 19. Verb – Get Parameters (Verb ID=F00h)

| Get Parameter Command Format | | | | Codec Response Format |
|------------------------------|--------------------|-------------------|--------------------------|------------------------|
| Bit [31:28] | Bit [27:20] | Bit [19:8] | Payload Bit [7:0] | Response [31:0] |
| CAd=X | Node ID=00h | Verb ID=F00h | Parameter ID[7:0] | 32-bit Response |

Note: If the parameter ID is not supported, the returned response is 32 bits of '0'.

8.1.1. Parameter – Vendor ID (Verb ID=F00h, Parameter ID=00h)

Table 20. Parameter – Vendor ID (Verb ID=F00h, Parameter ID=00h)

Codec Response Format

| Bit | Description |
|-------|--|
| 31:16 | Vendor ID=10ECh (Realtek's PCI vendor ID). |
| 15:0 | Device ID=0272h. |

Note 1: The Root Node (NID=00h) supports this parameter.

8.1.2. Parameter – Revision ID (Verb ID=F00h, Parameter ID=02h)

Table 21. Parameter – Revision ID (Verb ID=F00h, Parameter ID=02h)

Codec Response Format

| Bit | Description |
|-------|---|
| 31:24 | Reserved. Read as 0's. |
| 23:20 | MajRev=1h. The major version number (in decimal) of the HDA Specification to which the ALC272 is fully compliant. |
| 19:16 | MinRev=0h. The minor version number (in decimal) of the HDA Specification to which the ALC272 is fully compliant. |
| 15:8 | Revision ID. The vendor's revision number. Note: 00h indicates ALC272 silicon. |
| 7:0 | Stepping ID. The vendor's stepping number within the given Revision ID. |

Note: The Root Node (NID=00h) supports this parameter.

8.1.3. Parameter – Subordinate Node Count (Verb ID=F00h, Parameter ID=04h)

For the root node, the Subordinate Node Count provides information about audio function group nodes associated with the root node.

For function group nodes, it provides the total number of widgets associated with this function node.

Table 22. Parameter – Subordinate Node Count (Verb ID=F00h, Parameter ID=04h)

Codec Response Format

| Bit | Description |
|-------|--|
| 31:24 | Reserved. Read as 0's. |
| 23:16 | Starting Node Number. The starting node number in the sequential widgets |
| 15:8 | Reserved. Read as 0's. |
| 7:0 | Total Number of Nodes. For a root node, this is the total number of function groups in the root node. For a function group, this is the total number of widget nodes in the function group. |

8.1.4. Parameter – Function Group Type (Verb ID=F00h, Parameter ID=05h)

Table 23. Parameter – Function Group Type (Verb ID=F00h, Parameter ID=05h)

Codec Response Format

| Bit | Description |
|------|--|
| 31:9 | Reserved. Read as 0's. |
| 8 | UnSol Capable. 0: Unsolicited response is not supported by this function group. 1: Unsolicited response is supported by this function group. |
| 7:0 | Function Group Type. 00h: Reserved 01h: Audio Function 02h: Modem Function 03h~7Fh: Reserved 80h~FFh: Vendor Defined Function |

8.1.5. Parameter– Audio Function Capabilities (Verb ID=F00h, Parameter ID=08h)

Table 24. Parameter – Audio Function Capabilities (Verb ID=F00h, Parameter ID=08h)

Codec Response Format

| Bit | Description |
|-------|--|
| 31:17 | Reserved. Read as 0's. |
| 16 | Beep Generator. A '1' indicates the presence of an integrated Beep generator within the Audio Function Group. |
| 15:12 | Reserved. Read as 0's. |
| 11:8 | Input Delay. Number of samples delay from analog input to HDA link. |
| 7:4 | Reserved. Read as 0's. |
| 3:0 | Output Delay. Number of samples delay from HDA link to analog output. |

8.1.6. Parameter – Audio Widget Capabilities (Verb ID=F00h, Parameter ID=09h)

Table 25. Parameter – Audio Widget Capabilities (Verb ID=F00h, Parameter ID=09h)

Codec Response Format

| Bit | Description |
|-------|---|
| 31:24 | Reserved. Read as 0's. |
| 23:20 | Widget Type. 0h: Audio Output 1h: Audio Input 2h: Mixer3h: Selector 4h: Pin Complex 5h: Power Widget 6h: Volume Knob Widget 7h~Eh: Reserved Fh: Vendor defined audio widget |
| 19:16 | Delay. Samples delayed between the HDA link and widgets. |
| 15:12 | Reserved. Read as 0's. |
| 11: | L-R Swap. 0: Left channel and right channel swapping is not supported 1: Left channel and right channel swapping is supported |
| 10 | Power Control. 0: Power control is not supported on this widget 1: Power control is supported on this widget |
| 9 | Digital. 0: An analog input or output converter 1: A widget translating digital data between the HDA link and digital I/O (SPDIF, I2S, etc.) |
| 8 | ConnList. Connection List. 0: Connected to HDA link. No Connection List Entry will be queried 1: Connection List Entry must be queried |
| 7 | UnsolCap. Unsolicited Capable. 0: Unsolicited response is not supported 1: Unsolicited response is supported |
| 6 | ProcWidget. Processing Widget. 0: No processing control 1: Processing control is supported |
| 5 | Reserved. Read as 0. |
| 4 | Format Override. <i>Note: The ALC272 supports 16/20/24-bit with 44.1kHz, 48kHz, 96kHz and 192kHz sample rate. The format (parameter ID=0Ah) must be queried</i> |
| 3 | AmpParOvr (AMP Param Override). Override amplifier parameters (Gain Control) in individual output Pin Complexes, ADCs, and Mixer widgets. |
| 2 | OutAmpPre (Out AMP Present). |
| 1 | InAmpPre (In AMP Present). There are amplifiers (Gain Control) in individual ADCs and Mixer widgets. |
| 0 | Stereo. 0: Mono Widget 1: Stereo Widget |

8.1.7. Parameter – Supported PCM Size, Rates (Verb ID=F00h, Parameter ID=0Ah)

Parameters in audio functions provide default information about formats. Individual converters have their own parameters to provide supported formats if their ‘Format Override’ bit is set.

Table 26. Parameter – Supported PCM Size, Rates (Verb ID=F00h, Parameter ID=0Ah)

Codec Response Format

| Bit | Description |
|-------|--|
| 31:21 | Reserved. Read as 0's. |
| 20 | B32. 32-bit audio format support. 0: Not supported 1: Supported |
| 19 | B24. 24-bit audio format support. 0: Not supported 1: Supported (The ALC272 DAC and ADC supports this format) |
| 18 | B20. 20-bit audio format support. 0: Not supported 1: Supported (The ALC272 DAC and ADC supports this format) |
| 17 | B16. 16-bit audio format support. 0: Not supported 1: Supported (The ALC272 DAC and ADC supports this format) |
| 16 | B8. 8-bit audio format support. 0: Not supported 1: Supported |
| 15:12 | Reserved. Read as 0's. |
| 11 | R12. 384kHz (=8*48kHz) rate support. 0: Not supported 1: Supported |
| 10 | R11. 192kHz (=4*48kHz) rate support. 0: Not supported 1: Supported (The ALC272 DAC and ADC support this sample rate) |
| 9 | R10. 176.4Hz (=4*44.1kHz) rate support. 0: Not supported 1: Supported |
| 8 | R9. 96kHz (=2*48kHz) rate support. 0: Not supported 1: Supported (The ALC272 DAC and ADC support this sample rate) |
| 7 | R8. 88.2kHz (=2*44.1kHz) rate support. 0: Not supported 1: Supported |
| 6 | R7. 48kHz rate support. 0: Not supported 1: Supported (The ALC272 DAC and ADC support this sample rate) |
| 5 | R6. 44.1kHz rate support. 0: Not supported 1: Supported (ALC272 DAC and ADC support this sample rate) |
| 4 | R5. 32kHz (=2/3*48kHz) rate support. 0: Not supported 1: Supported |
| 3 | R4. 22.05kHz (=1/2*44.1kHz) rate support. 0: Not supported 1: Supported |
| 2 | R3. 16kHz (=1/3*48kHz) rate support. 0: Not supported 1: Supported |
| 1 | R2. 11.025kHz (=1/4*44.1kHz) rate support. 0: Not supported 1: Supported |
| 0 | R1. 8kHz (=1/6*48kHz) rate support. 0: Not supported 1: Supported |

8.1.8. Parameter – Supported Stream Formats (Verb ID=F00h, Parameter ID=0Bh)

Parameters in this node only provide default information for audio function groups. Individual converters have their own parameters to provide supported formats if the ‘Format Override’ bit is set.

Table 27. Parameter – Supported Stream Formats (Verb ID=F00h, Parameter ID=0Bh)

Codec Response Format

| Bit | Description |
|------|---|
| 31:3 | Reserved. Read as 0’s. |
| 2 | AC3. 0: Not supported 1: Supported |
| 1 | Float32. 0: Not supported 1: Supported |
| 0 | PCM. 0: Not supported 1: Supported (The ALC272 DAC and ADC support this format) |

Note: Input converters and output converters support this parameter.

8.1.9. Parameter – Pin Capabilities (Verb ID=F00h, Parameter ID=0Ch)

The Pin Capabilities parameter returns a bit field describing the capabilities of the Pin Complex widget.

Table 28. Parameter – Pin Capabilities (Verb ID=F00h, Parameter ID=0Ch)

Codec Response Format

| Bit | Description | | | | | | | | | | | | | | |
|----------|--|-----|----------|--------|-----|------|---|---|----------|------|-----|----------|--------|-----|------|
| 31:16 | Reserved. Read as 0’s. | | | | | | | | | | | | | | |
| 15:8 | VREF Control Capability. ‘1’ in corresponding bit field indicates signal levels of associated Vrefout are specified as a percentage of AVDD. <table border="1" style="margin-left: 40px;"> <thead> <tr> <th>7:6</th> <th>5</th> <th>4</th> <th>3</th> <th>2</th> <th>1</th> <th>0</th> </tr> </thead> <tbody> <tr> <td>Reserved</td> <td>100%</td> <td>80%</td> <td>Reserved</td> <td>Ground</td> <td>50%</td> <td>Hi-Z</td> </tr> </tbody> </table> | 7:6 | 5 | 4 | 3 | 2 | 1 | 0 | Reserved | 100% | 80% | Reserved | Ground | 50% | Hi-Z |
| 7:6 | 5 | 4 | 3 | 2 | 1 | 0 | | | | | | | | | |
| Reserved | 100% | 80% | Reserved | Ground | 50% | Hi-Z | | | | | | | | | |
| 7 | Reserved. | | | | | | | | | | | | | | |
| 6 | Balanced I/O Pin. ‘1’ indicates this pin complex has balanced pins. | | | | | | | | | | | | | | |
| 5 | Input Capable. ‘1’ indicates this pin complex supports input. | | | | | | | | | | | | | | |
| 4 | Output Capable. ‘1’ indicates this pin complex supports output. | | | | | | | | | | | | | | |
| 3 | Headphone Drive Capable. ‘1’ indicates this pin complex has an amplifier to drive a headphone. | | | | | | | | | | | | | | |
| 2 | Presence Detect Capable. ‘1’ indicates this pin complex can detect whether there is a device plugged in. | | | | | | | | | | | | | | |
| 1 | Trigger Required. ‘1’ indicates whether a software trigger is required for an impedance measurement. | | | | | | | | | | | | | | |
| 0 | Impedance Sense Capable. ‘1’ indicates this pin complex can perform analog sense on the attached device to determine its type. | | | | | | | | | | | | | | |

Note: Only Pin Complex widgets support this parameter.

8.1.10. Parameter– Amplifier Capabilities (Verb ID=F00h, Input Amplifier Parameter ID=0Dh)

Parameters in this node provide audio function group default information. Individual converters have their own parameters to provide amplifier capabilities if the ‘AMP Param Override’ bit is set.

Table 29. Parameter – Amplifier Capabilities (Verb ID=F00h, Input Amplifier Parameter ID=0Dh)

Codec Response Format

| Bit | Description |
|-------|---|
| 31 | (Input) Mute Capable. |
| 30:23 | Reserved. Read as 0. |
| 22:16 | Step Size. Indicates the size of each step in the gain range. |
| 15 | Reserved. Read as 0. |
| 14:8 | Number of Steps. Indicates the number of steps in the gain range. ‘0’ means the gain is fixed. |
| 7 | Reserved. Read as 0. |
| 6:0 | Offset. Indicates which step is 0dB. |

8.1.11. Parameter – Amplifier Capabilities (Verb ID=F00h, Output Amplifier Parameter ID=12h)

Parameters in this node provide audio function group default information. Individual converters have their own parameters to provide amplifier capabilities if the ‘AMP Param Override’ bit is set.

Table 30. Parameter – Amplifier Capabilities (Verb ID=F00h, Output Amplifier Parameter ID=12h)

Codec Response Format

| Bit | Description |
|-------|---|
| 31 | (Output) Mute Capable. |
| 30:23 | Reserved. Read as 0. |
| 22:16 | Step Size. Indicates the size of each step in the gain range. Each individual step may be 0~32dB, specified in 0.25dB steps. ‘0’ indicates 0.25dB steps. ‘127’ indicates 32dB steps. |
| 15 | Reserved. Read as 0. |
| 14:8 | Number of Steps. Indicates the number of steps in the gain range. ‘0’ means the gain is fixed. |
| 7 | Reserved. Read as 0. |
| 6:0 | Offset. Indicates which step is 0dB. |

8.1.12. Parameter – Connect List Length (Verb ID=F00h, Parameter ID=0Eh)

Parameters in this node provide audio function widget connection information.

Table 31. Parameter – Connect List Length (Verb ID=F00h, Parameter ID=0Eh)

Codec Response Format

| Bit | Description |
|------|---|
| 31:8 | Reserved. Read as 0. |
| 7 | Short Form. 0: Short Form 1: Long Form |
| 6:0 | Connect List Length. Indicates the number of inputs connected to a widget. If the Connect List Length is 1, there is only one input, and there is no Connection Select Control (not a MUX widget). |

8.1.13. Parameter – Supported Power States (Verb ID=F00h, Parameter ID=0Fh)

Table 32. Parameter – Supported Power States (Verb ID=F00h, Parameter ID=0Fh)

Codec Response Format

| Bit | Description |
|------|--|
| 31 | Extended Power States Supported (EPSS). 1: Extended power state EPSS is supported |
| 30 | CLKSTOP. 1: D3 mode operates even when no BITCLK presents on the link |
| 29:4 | Reserved. Read as 0's. |
| 3 | D3Sup. 1: Power state D3 is supported |
| 2 | D2Sup 1: Power state D2 is supported |
| 1 | D1Sup 1: Power state D1 is supported |
| 0 | D0Sup 1: Power state D0 is supported |

8.1.14. Parameter – Processing Capabilities (Verb ID=F00h, Parameter ID=10h)

Table 33. Parameter – Processing Capabilities (Verb ID=F00h, Parameter ID=10h)

Codec Response Format

| Bit | Description |
|-------|---|
| 31:16 | Reserved. Read as 0's. |
| 15:8 | NumCoeff. Number of Coefficient. |
| 7:1 | Reserved. Read as 0's. |
| 0 | Benign. 0: Processing unit is not linear and time invariant 1: Processing unit is linear and time invariant |

8.1.15. Parameter – GPIO Capabilities (Verb ID=F00h, Parameter ID=11h)

Table 34. Parameter – GPIO Capabilities (Verb ID=F00h, Parameter ID=11h)

Codec Response Format

| Bit | Description |
|-------|---|
| 31 | GPIWake=0. The ALC272 does not support GPIO wake-up function. |
| 30 | GPIUnsol=1. The ALC272 supports GPIO unsolicited response. |
| 29:24 | Reserved. Read as 0's. |
| 23:16 | NumGPIs=00h. No GPI pin is supported. |
| 15:8 | NumGPOs=00h. No GPO pin is supported. |
| 7:0 | NumGPIOs=02h. Two GPIO pins are supported. |

8.1.16. Parameter – Volume Knob Capabilities (Verb ID=F00h, Parameter ID=13h)

Table 35. Parameter – Volume Knob Capabilities (Verb ID=F00h, Parameter ID=13h)

Codec Response Format for NID=21h (Volume Control Knob)

| Bit | Description |
|------|--|
| 31:8 | Reserved. Read as 0's. |
| 7 | Delta. 0: Software cannot modify the Volume Control Knob volume 1: Software can write a base volume to the Volume Control Knob |
| 6:0 | NumSteps. The number of steps in the range of the Volume Control Knob. |

Note: The ALC272 does not support volume knob and will respond with 0s to this parameter.

8.2. Verb – Get Connection Select Control (Verb ID=F01h)

Table 36. Verb – Get Connection Select Control (Verb ID=F01h)

Get Command Format

| Bit [31:28] | Bit [27:20] | Bit [19:8] | Payload Bit [7:0] |
|-------------|-------------|--------------|-------------------|
| CAd=X | Node ID=Xh | Verb ID=F01h | 0's |

Codec Response Format

| Response [31:0] |
|-------------------------------|
| Bit[7:0] are Connection Index |

Codec Response for NID = 14h (LOUT1, PORT-D)

| Bit | Description |
|------|---|
| 31:8 | 0's. |
| 7:0 | Connection Index Currently Set (Default value is 00h). 00h: Sum Widget NID=0Ch 01h: Sum Widget NID=0Dh Other: Reserved |

Codec Response for NID = 15h (LOUT2, PORT-A)

| Bit | Description |
|------|---|
| 31:8 | 0's. |
| 7:0 | Connection Index Currently Set (Default value is 00h). 00h: Sum Widget NID=0Ch 01h: Sum Widget NID=0Dh Other: Reserved |

Codec Response for NID = 19h (MIC2, PORT-F)

| Bit | Description |
|------|--|
| 31:8 | 0's. |
| 7:0 | Connection Index Currently Set (Default value is 00h). 00h: Sum Widget NID=0Ch 01h: Sum Widget NID=0Dh 02h: Sum Widget NID=0Eh Other: Reserved |

Codec Response for NID = 1Bh (LINE2, PORT-E)

| Bit | Description |
|------|--|
| 31:8 | 0's. |
| 7:0 | Connection Index Currently Set (Default value is 00h). 00h: Sum Widget NID=0Ch 01h: Sum Widget NID=0Dh 02h: Sum Widget NID=0Eh Other: Reserved |

Codec Response for NID = 21h (HP-OUT, PORT-I)

| Bit | Description |
|------|--|
| 31:8 | 0's. |
| 7:0 | Connection Index Currently Set (Default value is 00h). 00h: Sum Widget NID=0Ch 01h: Sum Widget NID=0Dh 02h: Sum Widget NID=0Eh Other: Reserved |

Codec Response for other NID

| Bit | Description |
|------|------------------------------------|
| 31:0 | Not Supported (returns 00000000h). |

8.3. Verb – Set Connection Select (Verb ID=701h)

Table 37. Verb – Set Connection Select (Verb ID=701h)

Set Command Format

| Bit [31:28] | Bit [27:20] | Bit [19:8] | Payload Bit [7:0] |
|-------------|-------------|--------------|--------------------|
| CAd=X | Node ID=Xh | Verb ID=701h | Select Index [7:0] |

Codec Response Format

| Response [31:0] |
|-------------------|
| 0's for all nodes |

8.4. Verb – Get Connection List Entry (Verb ID=F02h)

Table 38. Verb – Get Connection List Entry (Verb ID=F02h)

Get Command Format

| Bit [31:28] | Bit [27:20] | Bit [19:8] | Payload Bit [7:0] |
|-------------|-------------|--------------|-----------------------|
| CAd=X | Node ID=Xh | Verb ID=F02h | Offset Index - N[7:0] |

Codec Response Format

| Response [31:0] |
|-----------------|
| 32-bit Response |

Codec Response for NID=08h (ADC)

| Bit | Description |
|------|---|
| 31:8 | Connection List Entry (N+3), (N+2), and (N+1). Returns 000000h. |
| 7:0 | Connection List Entry (N). Returns 23h (Sum Widget) for N=0~3. Returns 00h for N>3. |

Codec Response for NID=09h (ADC)

| Bit | Description |
|------|---|
| 31:8 | Connection List Entry (N+3), (N+2), and (N+1). Returns 000000h. |
| 7:0 | Connection List Entry (N). Returns 22h (Sum Widget) for N=0~3. Returns 00h for N>3. |

Codec Response for NID=0Bh (Mixer)

| Bit | Description |
|-------|---|
| 31:24 | Connection List Entry (N+3). Return 1Bh (Pin Complex – LINE2) for N=0~3. Return 00h for N>7. |
| 23:16 | Connection List Entry (N+2). Return 1Ah (Pin Complex – LINE1) for N=0~3. Return 15h (Pin Complex – LOUT2) for N=4~7. Return 00h for N>7. |
| 15:8 | Connection List Entry (N+1). Return 19h (Pin Complex – MIC2) for N=0~3. Return 14h (Pin Complex – LOUT1) for N=4~7. Return 00h for N>7. |
| 7:0 | Connection List Entry (N). Return 18h (Pin Complex – MIC1) for N=0~3. Return 1Dh (Pin Complex – PCBEEP) for N=4~7. Return 00h for N>7. |

Codec Response for NID=0Ch (LOUT1 Sum)

| Bit | Description |
|------------|--|
| 31:24 | Connection List Entry (N). Returns 00h. |
| 23:16 | Connection List Entry (N+2). Returns 00h. |
| 15:8 | Connection List Entry (N+1). Returns 0Bh (Mixer) for N=0~3. Returns 00h for N>3. |
| 7:0 | Connection List Entry (N). Returns 02h (LOUT1 DAC) for N=0~3. Returns 00h for N>3. |

Codec Response for NID=0Dh (LOUT2 Sum)

| Bit | Description |
|------------|--|
| 31:24 | Connection List Entry (N). Returns 00h. |
| 23:16 | Connection List Entry (N+2). Returns 00h. |
| 15:8 | Connection List Entry (N+1). Returns 0Bh (Mixer) for N=0~3. Returns 00h for N>3. |
| 7:0 | Connection List Entry (N). Returns 03h (LOUT2 DAC) for N=0~3. Returns 00h for N>3. |

Codec Response for NID=0Fh (MONO Sum)

| Bit | Description |
|------------|--|
| 31:24 | Connection List Entry (N). Returns 00h. |
| 23:16 | Connection List Entry (N+2). Returns 00h. |
| 15:8 | Connection List Entry (N+1). Returns 0Bh (Mixer) for N=0~3. Returns 00h for N>3. |
| 7:0 | Connection List Entry (N). Returns 02h (LOUT1 DAC) for N=0~3. Returns 00h for N>3. |

Codec Response for NID=14h (LOUT1, Port-D)

| Bit | Description |
|------------|---|
| 31:24 | Connection List Entry (N+3). Return 00h. |
| 23:16 | Connection List Entry (N+2). Return 00h. |
| 15:8 | Connection List Entry (N+1). Return 0Dh (Sum Widget NID=0Dh) for N=0~3. Return 00h. |
| 7:0 | Connection List Entry (N). Return 0Ch (Sum Widget NID=0Ch) for N=0~3. Return 00h for N>3. |

Codec Response for NID=15h (LOUT2, Port-A)

| Bit | Description |
|------------|---|
| 31:24 | Connection List Entry (N+3). Return 00h. |
| 23:16 | Connection List Entry (N+2). Return 00h. |
| 15:8 | Connection List Entry (N+1). Return 0Dh (Sum Widget NID=0Dh) for N=0~3. Return 00h. |
| 7:0 | Connection List Entry (N). Return 0Ch (Sum Widget NID=0Ch) for N=0~3. Return 00h for N>3. |

Codec Response for NID=17h (MONO, Port-H)

| Bit | Description |
|------------|---|
| 31:8 | Connection List Entry (N+3), (N+2), (N+1). Returns 000000h for n>3. |
| 7:0 | Connection List Entry (N). Returns 0Fh (Sum Widget NID=0Fh) for N=0~3. Returns 00h for N>3. |

Codec Response for NID=18h (MIC1, Port-B)

| Bit | Description |
|------------|--|
| 31:8 | Connection List Entry (N+3), (N+2), (N+1). Returns 000000h for n>3. |
| 7:0 | Connection List Entry (N). Returns 00h for N>3. |

Codec Response for NID=19h (MIC2, Port-F)

| Bit | Description |
|------------|---|
| 31:24 | Connection List Entry (N+3). Return 00h. |
| 23:16 | Connection List Entry (N+2). Return 00h for N>3. |
| 15:8 | Connection List Entry (N+1). Return 0Dh (Sum Widget NID=0Dh) for N=0~3. Return 00h for N>3. |
| 7:0 | Connection List Entry (N). Return 0Ch (Sum Widget NID=0Ch) for N=0~3. Return 00h for N>3. |

Codec Response for NID=1Ah (LINE1, Port-C)

| Bit | Description |
|------------|---|
| 31:8 | Connection List Entry (N+3), (N+2), (N+1). Returns 000000h for n>3. |
| 7:0 | Connection List Entry (N). Returns 0Dh (Sum Widget NID=0Dh) for N=0~3. Returns 00h for N>3. |

Codec Response for NID=1Bh (LINE2, Port-E)

| Bit | Description |
|------------|---|
| 31:24 | Connection List Entry (N+3). Return 00h. |
| 23:16 | Connection List Entry (N+2). Return 00h for N>3. |
| 15:8 | Connection List Entry (N+1). Return 0Dh (Sum Widget NID=0Dh) for N=0~3. Return 00h for N>3. |
| 7:0 | Connection List Entry (N). Return 0Ch (Sum Widget NID=0Ch) for N=0~3. Return 00h for N>3. |

Codec Response for NID=21h (HP-OUT, Port-I)

| Bit | Description |
|------------|---|
| 31:24 | Connection List Entry (N+3). Return 00h. |
| 23:16 | Connection List Entry (N+2). Return 00h for N>3. |
| 15:8 | Connection List Entry (N+1). Return 0Dh (Sum Widget NID=0Dh) for N=0~3. Return 00h for N>3. |
| 7:0 | Connection List Entry (N). Return 0Ch (Sum Widget NID=0Ch) for N=0~3. Return 00h for N>3. |

Codec Response for NID=1Eh (Pin Widget: SPDIF-OUT1)

| Bit | Description |
|------------|---|
| 31:8 | Connection List Entry (N+3), (N+2), and (N+1). Returns 000000h. |
| 7:0 | Connection List Entry (N). Returns 06h (SPDIF-OUT1 Converter) for N=0~3. Returns 00h for N>3. |

Codec Response for NID=11h (Pin Widget: SPDIF-OUT2)

| Bit | Description |
|------------|---|
| 31:8 | Connection List Entry (N+3), (N+2), and (N+1). Returns 000000h. |
| 7:0 | Connection List Entry (N). Returns 10h (SPDIF-OUT2 Converter) for N=0~3. Returns 00h for N>3. |

Codec Response for NID=22h (Sum Widget)

| Bit | Description |
|------------|--|
| 31:24 | Connection List Entry (N+3). Return 1Bh (Pin Complex – LINE2) for N=0~3. Return 00h for N>7. |
| 23:16 | Connection List Entry (N+2). Return 1Ah (Pin Complex – LINE1) for N=0~3. Return 15h (Pin Complex-LOUT2) for N=4~7. Return 00h for N>7. |
| 15:8 | Connection List Entry (N+1). Return 19h (Pin Complex – MIC2) for N=0~3. Return 14h (Pin Complex – LOUT1) for N=4~7. Return 12h (DMIC-1/2) for N=8~11. Return 00h for N>11. |
| 7:0 | Connection List Entry (N). Return 18h (Pin Complex – MIC1) for N=0~3. Return 1Dh (Pin Complex – PCBEEP) for N=4~7. Return 0Bh (Mixer) for N=8~11. Return 00h for N>11. |

Codec Response for NID=23h (Sum Widget)

| Bit | Description |
|-------|--|
| 31:24 | Connection List Entry (N+3). Return 1Bh (Pin Complex – LINE2) for N=0~3. Return 00h for N>7. |
| 23:16 | Connection List Entry (N+2). Return 1Ah (Pin Complex – LINE1) for N=0~3. Return 15h (Pin Complex-LOUT2) for N=4~7. Return 00h for N>7. |
| 15:8 | Connection List Entry (N+1). Return 19h (Pin Complex – MIC2) for N=0~3. Return 14h (Pin Complex – LOUT1) for N=4~7. Return 00h for N>11. |
| 7:0 | Connection List Entry (N). Return 18h (Pin Complex – MIC1) for N=0~3. Return 1Dh (Pin Complex – PCBEEP) for N=4~7. Return 0Bh (Mixer) for N=8~11. Return 00h for N>11. |

Codec Response for Other NID

| Bit | Description |
|------|-----------------------------------|
| 31:0 | Not Supported (returns 00000000h) |

8.5. Verb – Get Processing State (Verb ID=F03h)

Table 39. Verb – Get Processing State (Verb ID=F03h)

Get Command Format

| Bit [31:28] | Bit [27:20] | Bit [19:8] | Payload Bit [7:0] |
|-------------|-------------|--------------|-------------------|
| CAd=X | Node ID=Xh | Verb ID=F03h | 0's |

Codec Response Format

| Response [31:0] |
|-----------------|
| 32-bit response |

Codec Response for All NID

| Bit | Description |
|------|------------------------------------|
| 31:0 | Not Supported (returns 00000000h). |

8.6. Verb – Set Processing State (Verb ID=703h)

Table 40. Verb – Set Processing State (Verb ID=703h)

Set Command Format

| Bit [31:28] | Bit [27:20] | Bit [19:8] | Payload Bit [7:0] |
|-------------|-------------|--------------|------------------------|
| CAd=X | Node ID=Xh | Verb ID=703h | Processing State [7:0] |

Codec Response Format

| Response [31:0] |
|-------------------|
| 0's for all nodes |

Codec Response for all NID

| Bit | Description |
|------|-------------|
| 31:0 | 0's. |

8.7. Verb – Get Coefficient Index (Verb ID=Dh)

Table 41. Verb – Get Coefficient Index (Verb ID=Dh)

| Get Command Format | | | | Codec Response Format | |
|--------------------|--------------------|--------------------|---------------------------|----------------------------------|--|
| Bit [31:28] | Bit [27:20] | Bit [19:16] | Payload Bit [15:0] | Response [31:0] | |
| CAd=X | Node ID=20h | Verb ID=Dh | 0's | Bit [15:0] are Coefficient Index | |

Codec Response for NID=20h (Realtek Defined Registers)

| Bit | Description |
|-------|------------------------|
| 31:16 | Reserved. Read as 0's. |
| 15:0 | Coefficient Index. |

Codec Response for Other NID

| Bit | Description |
|------|------------------------------------|
| 31:0 | Not Supported (returns 00000000h). |

8.8. Verb – Set Coefficient Index (Verb ID=5h)

Table 42. Verb – Set Coefficient Index (Verb ID=5h)

| Set Command Format | | | | Codec Response Format | |
|--------------------|--------------------|--------------------|---------------------------|------------------------|--|
| Bit [31:28] | Bit [27:20] | Bit [19:16] | Payload Bit [15:0] | Response [31:0] | |
| CAd=X | Node ID=20h | Verb ID=5h | Coefficient Index [15:0] | 0's for all nodes | |

Codec Response for All NID

| Bit | Description |
|------|-------------|
| 31:0 | 0's. |

8.9. Verb – Get Processing Coefficient (Verb ID=Ch)

Table 43. Verb – Get Processing Coefficient (Verb ID=Ch)

| Get Command Format | | | | Codec Response Format | |
|--------------------|--------------------|--------------------|---------------------------|-------------------------------|--|
| Bit [31:28] | Bit [27:20] | Bit [19:16] | Payload Bit [15:0] | Response [31:0] | |
| CAd=X | Node ID=20h | Verb ID=Ch | 0's | Processing Coefficient [15:0] | |

Codec Response for NID=20h (Realtek Defined Registers)

| Bit | Description |
|-------|-------------------------|
| 31:16 | Reserved. Read as 0's. |
| 15:0 | Processing Coefficient. |

Codec Response for Other NID

| Bit | Description |
|------|------------------------------------|
| 31:0 | Not Supported (returns 00000000h). |

8.10. Verb – Set Processing Coefficient (Verb ID=4h)

Table 44. Verb – Set Processing Coefficient (Verb ID=4h)

Set Command Format

| Bit [31:28] | Bit [27:20] | Bit [19:16] | Payload Bit [15:0] |
|-------------|-------------|-------------|--------------------|
| CAd=X | Node ID=20h | Verb ID=4h | Coefficient [15:0] |

Codec Response Format

| Response [31:0] |
|-------------------|
| 0's for all nodes |

Codec Response for All NID

| Bit | Description |
|------|-------------|
| 31:0 | 0's. |

8.11. Verb – Get Amplifier Gain (Verb ID=Bh)

This verb is used to get gain/attenuation settings from each widget.

Table 45. Verb – Get Amplifier Gain (Verb ID=Bh)

Get Command Format

| Bit [31:28] | Bit [27:20] | Bit [19:16] | Payload Bit [15:0] |
|-------------|-------------|-------------|----------------------|
| CAd=X | Node ID=Xh | Verb ID=Bh | 'Get' payload [15:0] |

Codec Response Format

| Response [31:0] |
|------------------------------------|
| Bit[7:0] are responsible for 'Get' |

'Get' Payload in Command Bit[15:0]

| Bit | Description |
|------|--|
| 15 | Get Input/Output. 0: Input amplifier gain is requested 1: Output amplifier gain is requested |
| 14 | Reserved. Read as 0. |
| 13 | Get Left/Right. 0: Right amplifier gain is requested 1: Left amplifier gain is requested |
| 12:4 | Reserved. Read as 0's. |
| 3:0 | Index[3:0] for Input Source. Select amplifier for this converter. If a widget has no multiple input sources, the index will be ignored. |

Codec Response for 02h (LOUT1 DAC), 03h (LOUT2 DAC)

| Bit | Description |
|------|---|
| 31:8 | 0's. |
| 7 | Bit-15 is 0 in 'Get Amplifier Gain'. Read as 0 (No Input Amplifier Mute). Bit-15 is 1 in 'Get Amplifier Gain'. Read as 0 (No Output Amplifier Mute). |
| 6:0 | Bit-15 is 0 in 'Get Amplifier Gain'. Read as 0 (No Input Amplifier Gain). Bit-15 is 1 in 'Get Amplifier Gain': Output Amplifier Gain [6:0]. 7-bit step value (0~64) specifying the volume from -64B~0dB in 1dB steps. |

Codec Response for 08h (ADC)

| Bit | Description |
|------|--|
| 31:8 | 0's. |
| 7 | Bit-15 is 0 in 'Get Amplifier Gain'. Input Amplifier Mute. 0: Unmute; 1: Mute Bit-15 is 1 in 'Get Amplifier Gain'. Read as 0 (No Output Amplifier Mute). |
| 6:0 | Bit-15 is 0 in 'Get Amplifier Gain'. Input Amplifier Gain [6:0]. 7-bit step value (0~31) specifying the volume from -16.5dB~+30dB in 1.5dB steps. Bit-15 is 1 in 'Get Amplifier Gain'. Read as 0's (No Output Amplifier Mute). |

Codec Response for 09h (ADC)

| Bit | Description |
|------|--|
| 31:8 | 0's. |
| 7 | Bit-15 is 0 in 'Get Amplifier Gain'. Input Amplifier Mute. 0: Unmute; 1: Mute Bit-15 is 1 in 'Get Amplifier Gain'. Read as 0 (No Output Amplifier Mute). |
| 6:0 | Bit-15 is 0 in 'Get Amplifier Gain'. Input Amplifier Gain [6:0]. 7-bit step value (0~31) specifying the volume from -16.5dB~+30dB in 1.5dB steps. Bit-15 is 1 in 'Get Amplifier Gain'. Read as 0's (No Output Amplifier Mute). |

Codec Response for NID=0Bh (MIXER Sum Widget)

| Bit | Description |
|------|--|
| 31:8 | 0's |
| 7 | Bit-15 is 0 in 'Get Amplifier Gain'. Input Amplifier Mute. 0: Unmute; 1: Mute (Default for all Index) Bit-15 is 1 in 'Get Amplifier Gain'. Read as 0 (No Output Amplifier Mute). |
| 6:0 | Bit-15 is 0 in 'Get Amplifier Gain'. Input Amplifier Gain [6:0]. 7-bit step value (0~31) specifying the volume from -34.5dB~+12dB in 1.5dB steps. Bit-15 is 1 in 'Get Amplifier Gain'. Read as 0's (No Output Amplifier Mute). |

Codec Response for NID=0Ch~0Fh (Sum Widget: LOUT1, LOUT2, MONO)

| Bit | Description |
|------|---|
| 31:8 | 0's. |
| 7 | Bit-15 is 0 in 'Get Amplifier Gain'. Input Amplifier Mute. 0: Unmute; 1: Mute Bit-15 is 1 in 'Get Amplifier Gain'. Read as 0 (No Output Amplifier Mute). |
| 6:0 | Bit-15 is 0 in 'Get Amplifier Gain'. Read as 0 (No Input Amplifier Gain). Bit-15 is 1 in 'Get Amplifier Gain'. Read as 0 (No Output Amplifier Gain). |

Codec Response for NID=14h, 15h, 17h and 21h (Pin Widget: LOUT1/LOUT2/MONO/HP-OUT)

| Bit | Description |
|------|---|
| 31:8 | 0's. |
| 7 | Bit-15 is 0 in 'Get Amplifier Gain'. Read as 0 (No Input Amplifier Mute). Bit-15 is 1 in 'Get Amplifier Gain': Output Amplifier Mute. 0:Unmute; 1:Mute (Default=1) |
| 6:0 | Bit-15 is 0 in 'Get Amplifier Gain'. Read as 0 (No Input Amplifier Gain). Bit-15 is 1 in 'Get Amplifier Gain'. Read as 0 (No Output Amplifier Gain). |

Codec Response for NID=18h, 19h, 1Ah and 1Bh (Pin Widget: MIC1/MIC2/LINE1/LINE2)

| Bit | Description |
|------------|---|
| 31:8 | 0's. |
| 7 | Bit-15 is 0 in 'Get Amplifier Gain'. Read as 0 (No Input Amplifier Mute). Bit-15 is 1 in 'Get Amplifier Gain': Output Amplifier Mute. 0:Unmute; 1:Mute (Default=1) |
| 6:0 | Bit-15 is 0 in 'Get Amplifier Gain'. Input Amplifier Gain [6:0]. Specifying the boost from 0dB/10dB/20dB/30dB in 10dB per step (Default=0, 0dB). Bit-15 is 1 in 'Get Amplifier Gain'. Read as 0 (No Output Amplifier Gain). |

Codec Response for NID=22h (Sum Widget)

| Bit | Description |
|------------|---|
| 31:8 | 0's |
| 7 | Bit-15 is 0 in 'Get Amplifier Gain'. Input Amplifier Mute. 0: Unmute; 1: Mute (Default=1 for all index) Bit-15 is 1 in 'Get Amplifier Gain'. Read as 0 (No Output Amplifier Mute). |
| 6:0 | Bit-15 is 0 in 'Get Amplifier Gain'. Read as 0 (No Input Amplifier Gain). Bit-15 is 1 in 'Get Amplifier Gain'. Read as 0 (No Output Amplifier Gain). |

Codec Response for NID=23h (Sum Widget)

| Bit | Description |
|------------|---|
| 31:8 | 0's |
| 7 | Bit-15 is 0 in 'Get Amplifier Gain'. Input Amplifier Mute. 0: Unmute; 1: Mute (Default=1 for all index) Bit-15 is 1 in 'Get Amplifier Gain'. Read as 0 (No Output Amplifier Mute). |
| 6:0 | Bit-15 is 0 in 'Get Amplifier Gain'. Read as 0 (No Input Amplifier Gain). Bit-15 is 1 in 'Get Amplifier Gain'. Read as 0 (No Output Amplifier Gain). |

Codec Response to Other NID

| Bit | Description |
|------------|------------------------------------|
| 31:0 | Not Supported (returns 00000000h). |

8.12. Verb – Set Amplifier Gain (Verb ID=3h)

This verb is used to set amplifier gain/attenuation in each widget.

Table 46. Verb – Set Amplifier Gain (Verb ID=3h)

Set Command Format

| Bit [31:28] | Bit [27:20] | Bit [19:8] | Payload Bit [7:0] |
|-------------|-------------|------------|---------------------|
| CAd=X | Node ID=Xh | Verb ID=3h | 'Set' payload [7:0] |

Codec Response Format

| Response [31:0] |
|-------------------|
| 0's for all nodes |

'Set' Payload in Command Bit[15:0]

| Bit | Description |
|------|---|
| 15 | Set Output Amp. 1: Indicates output amplifier gain will be set |
| 14 | Set Input Amp. 1: Indicates input amplifier gain will be set |
| 13 | Set Left Amp. 1: Indicates left amplifier gain will be set |
| 12 | Set Right Amp. 1: Indicates right amplifier gain will be set |
| 11:8 | Index Offset (for input amplifiers on Sum widgets and Selector Widgets). 5-bit index offset in connection list is used to select the input gain that will be set on a Sum or a Selector widget. The index is ignored if the node is not a Sum or a Selector widget, or the 'Set Input Amp' bit is not set. |
| 7 | Mute. 0: Unmute 1: Mute ($-\infty$ gain) |
| 6:0 | Gain[6:0]. A 7-bit step value specifying the amplifier gain |

8.13. Verb – Get Converter Format (Verb ID=Ah)

Table 47. Verb – Get Converter Format (Verb ID=Ah)

Get Command Format

| Bit [31:28] | Bit [27:20] | Bit [19:16] | Payload Bit [15:0] |
|-------------|-------------|-------------|--------------------|
| CAd=X | Node ID=Xh | Verb ID=Ah | 0's |

Codec Response Format

| Response [31:0] |
|--------------------------------|
| Bit[15:0] are converter format |

Codec Response for NID=02h~03h, 06h, 10h (Output Converters: LOUT1, LOUT2 DAC and SPDIF-OUT1/2).
 Codec Response for NID=08h and 09h (Input Converters: ADC 08h and ADC 09h)

| Bit | Description |
|-------|--|
| 31:16 | Reserved. Read as 0. |
| 15 | Stream Type (TYPE). 0: PCM 1: Non-PCM |
| 14 | Sample Base Rate (BASE). 0: 48kHz 1: 44.1kHz |
| 13:11 | Sample Base Rate Multiple (MULT). 000b: *1 001b: *2 010b: *3 011b: *4 100b~111b: Reserved |
| 10:8 | Sample Base Rate Divisor (DIV). 000b: /1 001b: /2 010b: /3 011b: /4 100b: /5 101b: /6 110b: /7 111b: /8 Not supported. Always read as 000b. |
| 7 | Reserved. Read as 0. |
| 6:4 | Bits per Sample (BITS). 000b: 8 bits 001b: 16 bits 010b: 20 bits 011b: 24 bits 100b: 32 bits 101b~111b: Reserved |
| 3:0 | Number of Channels. 0: 1 channel 1: 2 channels 2: 3 channels 15: 16 channels |

Table 48. Get Converter Format Support

| | BASE | MULT | DIV | BITS | Sample rate |
|----------------------|------|------------------|------|----------------|----------------|
| NID=02h (LOUT1 DAC) | 0 | 000b, 001b, 011b | 000b | 001,010b, 011b | 48K, 96K, 192K |
| | 1 | 000b | 000b | 001,010b, 011b | 44.1K |
| NID=03h (LOUT2 DAC) | 0 | 000b, 001b, 011b | 000b | 001,010b, 011b | 48K, 96K, 192K |
| | 1 | 000b | 000b | 001,010b, 011b | 44.1K |
| NID=06h (SPDIF-OUT1) | 0 | 000b, 001b, 011b | 000b | 001,010b, 011b | 48K, 96K, 192K |
| | 1 | 000b, 001b | 000b | 001,010b, 011b | 44.1K, 88.2K |
| NID=10h (SPDIF-OUT2) | 0 | 000b, 001b, 011b | 000b | 001,010b, 011b | 48K, 96K, 192K |
| | 1 | 000b, 001b | 000b | 001,010b, 011b | 44.1K, 88.2K |
| NID=08h (LINE ADC) | 0 | 000b, 001b, 011b | 000b | 001,010b, 011b | 48K, 96K, 192K |
| | 1 | 000b | 000b | 001,010b, 011b | 44.1K |
| NID=09h (MIX ADC) | 0 | 000b, 001b, 011b | 000b | 001,010b, 011b | 48K, 96K, 192K |
| | 1 | 000b | 000b | 001,010b, 011b | 44.1K |

Codec Response for other NID

| Bit | Description |
|------|------------------------------------|
| 31:0 | Not Supported (returns 00000000h). |

8.14. Verb – Set Converter Format (Verb ID=2h)

Table 49. Verb – Set Converter Format (Verb ID=2h)

Set Command Format

| Bit [31:28] | Bit [27:20] | Bit [19:16] | Payload Bit [15:0] |
|-------------|-------------|-------------|--------------------|
| CAd=X | Node ID=Xh | Verb ID=2h | Set format [15:0] |

Codec Response Format

| Response [31:0] |
|-------------------|
| 0's for all nodes |

'Set' Payload in Command Bit[15:0]

| Bit | Description |
|-------|---|
| 31:16 | Reserved. Read as 0. |
| 15 | Stream Type (TYPE). 0: PCM 1: Non-PCM |
| 14 | Sample Base Rate (BASE). 0: 48kHz 1: 44.1kHz |
| 13:11 | Sample Base Rate Multiple (MULT). 000b: *1 001b: *2 010b: *3 011b: *4 100b~111b: Reserved |
| 10:8 | Sample Base Rate Divisor (DIV). 000b: /1 001b: /2 010b: /3 011b: /4 100b: /5 101b: /6 110b: /7 111b: /8 |
| 7 | Reserved. Read as 0. |
| 6:4 | Bits per Sample (BITS). 000b: 8 bits 001b: 16 bits 010b: 20 bits 011b: 24 bits 100b: 32 bits 101b~111b: Reserved |
| 3:0 | Number of Channels. 0: 1 channel 1: 2 channels 2: 3 channels 15: 16 channels |

8.15. Verb – Get Power State (Verb ID=F05h)

The ALC272 is designed to meet Intel’s low-power-state white paper and is ECR HDA-015B compliant (see section 7.5 Power Management , page 24).

Table 50. Verb – Get Power State (Verb ID=F05h)

| Get Command Format | | | | Codec Response Format | |
|--------------------|--------------------|-------------------|--------------------------|------------------------|--|
| Bit [31:28] | Bit [27:20] | Bit [19:8] | Payload Bit [7:0] | Response [31:0] | |
| CAd=X | Node ID=Xh | Verb ID= F05h | 0’s | Power State [7:0] | |

Codec Response for NID=01h (Audio Function Group)

Codec Response for NID=02h, 03h, 08h, 09h (Analog Input/Output Converter)

Codec Response for NID=11h, 12h, 14h, 15h, 17h, 18h, 19h, 1Ah, 1Bh, 1Dh, 1Eh, 21h (Pin Widgets)

Codec Response for NID=06h, 10h (Digital Output Converter)

| Bit | Description |
|-------|--|
| 31:11 | Reserved. Read as 0’s. |
| 10 | PS-SettingsReset. 0: Setting of widgets have been reset during low power state 1: Setting changed from the default were reset to their default during low power state |
| 9 | PS-ClkStopOk. 0: No capability to operate normally with BITCLK stop 1: Operate properly with no BICLK |
| 8 | PS-Error. No support in ALC272 |
| 7:6 | Reserved. Read as 0’s. |
| 5:4 | PS-Act. Actual Power State [1:0]. 00: Power state is D0 01: Power state is D1 10: Power state is D2 11: Power state is D3 PS-Act indicates the actual power state of the referenced node. For Audio Function Group nodes (NID=01h), PS-Act is always equal to PS-Set. |
| 3:2 | Reserved. Read as 0’s. |
| 1:0 | PS-Set. Set Power State [1:0]. 00: Power state is D0 01: Power state is D1 10: Power state is D2 11: Power state is D3 PS-Set controls the current power setting of the referenced node. |

Codec Response for other NID

| Bit | Description |
|------|------------------------------------|
| 31:0 | Not Supported (returns 00000000h). |

8.16. Verb – Set Power State (Verb ID=705h)

Table 51. Verb – Set Power State (Verb ID=705h)

Set Command Format

| Bit [31:28] | Bit [27:20] | Bit [19:8] | Payload Bit [7:0] |
|-------------|-------------|--------------|-------------------|
| CAd=X | Node ID=Xh | Verb ID=705h | Power State [7:0] |

Codec Response Format

| Response [31:0] |
|-------------------|
| 0's for all nodes |

'Power State' in Command Bit[7:0]

| Bit | Description |
|-----|--|
| 7:6 | Reserved. Read as 0's. |
| 5:4 | PS-Act. Actual Power State [1:0]. 00: Power state is D0 01: Power state is D1 10: Power state is D2 11: Power state is D3 PS-Act indicates the actual power state of the referenced node. |
| 3:2 | Reserved. Read as 0's. |
| 1:0 | PS-Set. Set Power State [1:0]. 00: Power state is D0 01: Power state is D1 10: Power state is D2 11: Power state is D3 |

8.17. Verb – Get Converter Stream, Channel (Verb ID=F06h)

Table 52. Verb – Get Converter Stream, Channel (Verb ID=F06h)

Get Command Format

| Bit [31:28] | Bit [27:20] | Bit [19:8] | Payload Bit [7:0] |
|-------------|-------------|--------------|-------------------|
| CAd=X | Node ID=Xh | Verb ID=F06h | 0's |

Codec Response Format

| Response [31:0] |
|------------------------|
| Stream & Channel [7:0] |

Codec Response for NID=02h~03h, 06h and 10h (Output Converters: LOUT1, LOUT2 DAC, and SPDIF-OUT1/2)

Codec Response for NID=08h and 09h (Input Converters: LINE, MIX ADC)

| Bit | Description |
|------|---|
| 31:8 | Reserved. Read as 0's. |
| 7:4 | Stream[3:0]. The link stream used by the converter. 0000b is unused, 0001b is stream 1, etc. |
| 3:0 | Channel[3:0]. The lowest channel used by the converter. A stereo converter will use the set channel n as well as n+1 for its left and right channel. |

Codec Response for other NID

| Bit | Description |
|------|------------------------------------|
| 31:0 | Not Supported (returns 00000000h). |

8.20. Verb – Set Pin Widget Control (Verb ID=707h)

Table 55. Verb – Set Pin Widget Control (Verb ID=707h)

Set Command Format

| Bit [31:28] | Bit [27:20] | Bit [19:8] | Payload Bit [7:0] |
|-------------|-------------|--------------|-------------------|
| CAd=X | Node ID=Xh | Verb ID=707h | Pin Control [7:0] |

Codec Response Format

| Response [31:0] |
|-------------------|
| 0's for all nodes |

Codec Response for NID=11h, 12h, 14h, 15h, 17h, 18h, 19h, 1Ah, 1Bh, 1Dh, 1Eh, 21h (Pin Complex)

| Bit | Description |
|------|---|
| 31:8 | Reserved. Read as 0's. |
| 7 | H-Phn Enable. 0: Disabled 1: Enabled <i>Note: Only NID=14h, 15h, 19A, 1Bh, and 21h support headphone amplifier.</i> |
| 6 | Out Enable (Output Buffet Enable, EN_OBUF for an I/O unit). 0: Disabled 1: Enabled <i>Note: NID= 1Dh (PCBEEP) do not support output and are always read 0.</i> |
| 5 | In Enable (Input Buffer Enable, EN_IBUF for an I/O unit). 0: Disabled 1: Enabled <i>Note: NID=1Eh (1st SPDIF-OUT) and 11h (2nd SPDIF-OUT) do not support output and is always read 0.</i> |
| 4:3 | Reserved. |
| 2:0 | VrefEn (Vrefout Enable Control). 000b: Hi-Z (Disabled, default for all) 001b: 50% of AVDD 010b: Ground 0V 011b: Reserved 100b: 80% of AVDD 101b: 100% of AVDD 110b~111b: Reserved <i>Note: Only NID=18h, 19h, 1Ah and 1Bh support reference output, other nodes will ignore this verb and respond with 0.</i> |

8.23. Verb – Get Pin Sense (Verb ID=F09h)

Returns the Presence Detect status and the impedance of a device attached to the pin.

Table 58. Verb – Get Pin Sense (Verb ID=F09h)

Get Command Format

| Bit [31:28] | Bit [27:20] | Bit [19:8] | Payload Bit [7:0] |
|-------------|-------------|---------------|-------------------|
| CAd=X | Node ID=Xh | Verb ID= F09h | 0's |

Codec Response Format

| Response [31:0] |
|-----------------|
| 32-bit Response |

Codec Response for NID=14h, 15h, 18h, 19h, 1Ah, 1Bh, 21h

| Bit | Description |
|------|---|
| 31 | Presence Detect Status. 0: No device is attached to the pin 1: Device is attached to the pin |
| 30:0 | Measured Impedance. The ALC272 does not support hardware impedance detect. This field is read as 0s. |

Codec Response for other NID

| Bit | Description |
|------|------------------------------------|
| 31:0 | Not Supported (returns 00000000h). |

8.24. Verb – Execute Pin Sense (Verb ID=709h)

Table 59. Verb – Execute Pin Sense (Verb ID=709h)

Command Format

| Bit [31:28] | Bit [27:20] | Bit [19:8] | Payload Bit [7:0] |
|-------------|-------------|---------------|-------------------|
| CAd=X | Node ID=Xh | Verb ID= 709h | Right Channel[0] |

Codec Response Format

| Response [31:0] |
|-------------------|
| 0's for all nodes |

'Payload' in Command Bit[7:0] (for NID=14h, 15h, 18h, 19h, 1Ah, 1Bh, 21h)

| Bit | Description |
|-----|---|
| 7:1 | Reserved. Read as 0's. |
| 0 | Right (Ring) Channel Select. 0: Sense Left Channel (Tip) 1: Sense Right Channel (Ring) The ALC272 does not support hardware impedance detect and will ignore this control bit. |

8.25. Verb – Get Configuration Default (Verb ID=F1Ch/F1Dh/F1Eh/F1Fh)

Read the 32-bit sticky register for each Pin Widget configured by software.

Table 60. Verb – Get Configuration Default (Verb ID=F1Ch/F1Dh/F1Eh/F1Fh)

| Get Command Format | | | | Codec Response Format |
|--------------------|--------------------|-------------------|--------------------------|------------------------|
| Bit [31:28] | Bit [27:20] | Bit [19:8] | Payload Bit [7:0] | Response [31:0] |
| CAd=X | Node ID=Xh | Verb ID= F1Ch | 0's | 32-bit Response |

Codec Response for NID=14h, 15h, 17h, 18h, 19h, 1Ah, 1Bh, 21h, 1Dh, 1Eh, 11h, 12h
(Pin Widget: LOUT1, LOUT2, MONO, MIC1, MIC2, LINE1, LINE2, PCBEEP, HP-OUT, SPDIF-OUT1, SPDIF-OUT2, DMIC1/2)

| Bit | Description |
|------|---|
| 31:0 | 32-bit configuration information for each pin widget. |

Note: The 32-bit registers for each Pin Widget are sticky and will not be reset by a LINK Reset or Codec Reset (Function Reset Verb).

8.26. Verb – Set Configuration Default Bytes 0, 1, 2, 3 (Verb ID=71Ch/71Dh/71Eh/71Fh)

The BIOS can use this verb to figure out the default conditions (e.g., placement and expected default device) for the Pin Widgets NID=0B~0Fh, 10h, 11h, 1Fh, 20h, and 12h.

Table 61. Verb – Set Configuration Default Bytes 0, 1, 2, 3 (Verb ID=71Ch/71Dh/71Eh/71Fh)

| Set Command Format | | | | Codec Response Format |
|--------------------|--------------------|-----------------------------------|--------------------------|------------------------|
| Bit [31:28] | Bit [27:20] | Bit [19:8] | Payload Bit [7:0] | Response [31:0] |
| CAd=X | Node ID=Xh | Verb ID=71Ch, 71Dh, 71Eh, 71Fh | Label [7:0] | 0's for all nodes |

Note: Supported by Pin Widget NID=14h, 15h, 17h, 18h, 19h, 1Ah, 1Bh, 21h, 1Dh, 1Eh, 11h, 12h. Other widgets will ignore this verb.

Codec Response for All NID

| Bit | Description |
|------|-------------|
| 31:0 | 0's. |

8.27. Verb – Get BEEP Generator (Verb ID=F0Ah)

Table 62. Verb – Get BEEP Generator (Verb ID= F0Ah)

Get Command Format

| Bit [31:28] | Bit [27:20] | Bit [19:8] | Payload Bit [7:0] |
|-------------|-------------|---------------|-------------------|
| CAd=X | Node ID=01h | Verb ID= F1Bh | 0's |

Codec Response Format

| Response [31:0] |
|-----------------|
| Divider [7:0] |

'Response' for NID=01h

| Bit | Description |
|------|--|
| 31:8 | Reserved. |
| 7:0 | Frequency Divider, F[7:0]. The internal BEEP frequency is the result of dividing the 48kHz clock by 4 times the number specified in F[7:0]. The lowest tone is $48\text{kHz}/(255*4)=47\text{Hz}$. The highest tone is $48\text{kHz}/(1*4)=12\text{kHz}$. A value of 00h in F[7:0] disables the internal BEEP generator and allows external PCBEEP input. |

Codec Response for Other NID

| Bit | Description |
|------|-------------|
| 31:0 | 0's. |

8.28. Verb – Set BEEP Generator (Verb ID=70Ah)

Table 63. Verb – Set BEEP Generator (Verb ID= 70Ah)

Set Command Format

| Bit [31:28] | Bit [27:20] | Bit [19:8] | Payload Bit [7:0] |
|-------------|-------------|--------------|-------------------|
| CAd=X | Node ID=01h | Verb ID=71Bh | Divider [7:0] |

Codec Response Format

| Response [31:0] |
|-------------------|
| 0's for all nodes |

'Divider' in Set Command

| Bit | Description |
|------|--|
| 31:8 | Reserved. |
| 7:0 | Frequency Divider, F[7:0]. The internal BEEP frequency is the result of dividing the 48kHz clock by 4 times the number specified in F[7:0]. The lowest tone is $48\text{kHz}/(255*4)=47\text{Hz}$. The highest tone is $48\text{kHz}/(1*4)=12\text{kHz}$. A value of 00h in F[7:0] disables the internal BEEP generator and allows external PCBEEP input. |

Note: All nodes except BEEP generator (NID=01h) will ignore this verb.

Codec Response for All NID

| Bit | Description |
|------|-------------|
| 31:0 | 0's. |

8.29. Verb – Get GPIO Data (Verb ID= F15h)

Table 64. Verb – Get GPIO Data (Verb ID= F15h)

Get Command Format

| Bit [31:28] | Bit [27:20] | Bit [19:8] | Payload Bit [7:0] |
|-------------|-------------|--------------|-------------------|
| CAd=X | Node ID=01h | Verb ID=F15h | 0's |

Codec Response Format

| Response [31:0] |
|-----------------|
| 32-bit Response |

Codec Response for NID=01h (Audio Function Group)

| Bit | Description |
|------|--|
| 31:8 | Reserved. |
| 7:2 | Reserved. |
| 1:0 | GPIO[1:0] Data. The value written (output) or sensed (input) on the corresponding pin if it is enabled. |

Codec Response for Other NID

| Bit | Description |
|------|-------------|
| 31:0 | 0's. |

8.30. Verb – Set GPIO Data (Verb ID= 715h)

Table 65. Verb – Set GPIO Data (Verb ID= 715h)

Set Command Format

| Bit [31:28] | Bit [27:20] | Bit [19:8] | Payload Bit [7:0] |
|-------------|-------------|--------------|-------------------|
| CAd=X | Node ID=01h | Verb ID=715h | Data [7:0] |

Codec Response Format

| Response [31:0] |
|-------------------|
| 0's for all nodes |

'Data' in Set command for NID=01h (Audio Function Group)

| Bit | Description |
|------|---|
| 31:8 | Reserved. |
| 7:2 | Reserved. |
| 1:0 | GPIO[1:0] Output Data. The value written determines the value driven on a pin that is configured as an output pin. |

Codec Response for All NID

| Bit | Description |
|------|-------------|
| 31:0 | 0's. |

8.31. Verb – Get GPIO Enable Mask (Verb ID=F16h)

Table 66. Verb – Get GPIO Enable Mask (Verb ID= F16h)

Get Command Format

| Bit [31:28] | Bit [27:20] | Bit [19:8] | Payload Bit [7:0] |
|-------------|-------------|--------------|-------------------|
| CAd=X | Node ID=01h | Verb ID=F16h | 0's |

Codec Response Format

| Response [31:0] |
|------------------|
| EnableMask [7:0] |

Codec Response for NID=01h (Audio Function Group)

| Bit | Description |
|------|--|
| 31:8 | Reserved. |
| 7:2 | Reserved. |
| 1:0 | GPIO[1:0] Enable Mask. 0: The corresponding GPIO pin is disabled and is in Hi-Z state 1: The corresponding GPIO pin is enabled. Its behavior is determined by the GPIO direction control |

Note: All nodes except Audio Function Group (NID=01h) will ignore this verb.

Codec Response for Other NID

| Bit | Description |
|------|-------------|
| 31:0 | 0's. |

8.32. Verb – Set GPIO Enable Mask (Verb ID=716h)

Table 67. Verb – Set GPIO Enable Mask (Verb ID=716h)

Set Command Format

| Bit [31:28] | Bit [27:20] | Bit [19:8] | Payload Bit [7:0] |
|-------------|-------------|--------------|-------------------|
| CAd=X | Node ID=01h | Verb ID=716h | Enable Mask [7:0] |

Codec Response Format

| Response [31:0] |
|-------------------|
| 0's for all nodes |

Codec Response for NID=01h (Audio Function Group)

| Bit | Description |
|------|--|
| 31:8 | Reserved. |
| 7:2 | Reserved. |
| 1:0 | GPIO[1:0] Enable Mask. 0: The corresponding GPIO pin is disabled and is in Hi-Z state 1: The corresponding GPIO pin is enabled. Its behavior is determined by the GPIO direction control |

Note: All nodes except Audio Function Group (NID=01h) will ignore this verb.

Codec Response for All NID

| Bit | Description |
|------|-------------|
| 31:0 | 0's. |

8.33. Verb – Get GPIO Direction (Verb ID=F17h)

Table 68. Verb – Get GPIO Direction (Verb ID=F17h)

Get Command Format

| Bit [31:28] | Bit [27:20] | Bit [19:8] | Payload Bit [7:0] |
|-------------|-------------|--------------|-------------------|
| CAd=X | Node ID=01h | Verb ID=F17h | 0's |

Codec Response Format

| Response [31:0] |
|-----------------|
| Direction [7:0] |

Codec Response for NID=01h (Audio Function Group)

| Bit | Description |
|------|---|
| 31:8 | Reserved. |
| 7:2 | Reserved. |
| 1:0 | GPIO[1:0] Direction Control. 0: The corresponding GPIO pin is configured as an input 1: The corresponding GPIO pin is configured as an output |

Note: All nodes except Audio Function Group (NID=01h) will ignore this verb.

Codec Response for Other NID

| Bit | Description |
|------|-------------|
| 31:0 | 0's. |

8.34. Verb – Set GPIO Direction (Verb ID=717h)

Table 69. Verb – Set GPIO Direction (Verb ID=717h)

Set Command Format

| Bit [31:28] | Bit [27:20] | Bit [19:8] | Payload Bit [7:0] |
|-------------|-------------|--------------|-------------------|
| CAd=X | Node ID=01h | Verb ID=717h | Direction [7:0] |

Codec Response Format

| Response [31:0] |
|-------------------|
| 0's for all nodes |

Codec Response for NID=01h (Audio Function Group)

| Bit | Description |
|------|---|
| 31:8 | Reserved. |
| 7:2 | Reserved. |
| 1:0 | GPIO[1:0] Direction Control. 0: The corresponding GPIO pin is configured as an input 1: The corresponding GPIO pin is configured as an output |

Note: All nodes except Audio Function Group (NID=01h) will ignore this verb.

Codec Response for Other NID

| Bit | Description |
|------|-------------|
| 31:0 | 0's. |

8.35. Verb – Get GPIO Unsolicited Response Enable Mask (Verb ID=F19h)

Table 70. Verb – Get GPIO Unsolicited Response Enable Mask (Verb ID=F19h)

Get Command Format

| Bit [31:28] | Bit [27:20] | Bit [19:8] | Payload Bit [7:0] |
|-------------|-------------|--------------|-------------------|
| CAd=X | Node ID=01h | Verb ID=F19h | 0's |

Codec Response Format

| Response [31:0] |
|-------------------|
| UnsolEnable [7:0] |

Codec Response for NID=01h (Audio Function Group)

| Bit | Description |
|------|--|
| 31:8 | Reserved. |
| 7:2 | Reserved. |
| 1:0 | GPIO[1:0] Unsolicited Enable Mask. 0: Unsolicited response will not be sent on link 1: Unsolicited response will be sent on link when state of corresponding GPIO has been changed |

Note: All nodes except Audio Function Group (NID=01h) will ignore this verb.

Codec Response for Other NID

| Bit | Description |
|------|-------------|
| 31:0 | 0's. |

8.36. Verb – Set GPIO Unsolicited Response Enable Mask (Verb ID=719h)

Table 71. Verb – Set GPIO Unsolicited Response Enable Mask (Verb ID=719h)

Set Command Format

| Bit [31:28] | Bit [27:20] | Bit [19:8] | Payload Bit [7:0] |
|-------------|-------------|--------------|-------------------|
| CAd=X | Node ID=01h | Verb ID=719h | UnsolEnable [7:0] |

Codec Response Format

| Response [31:0] |
|-------------------|
| 0's for all nodes |

Codec Response for NID=01h (Audio Function Group)

| Bit | Description |
|------|--|
| 31:8 | Reserved. |
| 7:2 | Reserved. |
| 1:0 | GPIO[1:0] Unsolicited Enable Mask. 0: Unsolicited response will not be sent on link 1: Unsolicited response will be sent on link when state of corresponding GPIO has been changed |

Note 1: All nodes except the Audio Function Group (NID=01h) will ignore this verb.
Note 2: The unsolicited response of corresponding GPIO is enabled when it's 'Enable Mask' and Verb- 'Unsolicited Response' for NID=01h are enabled.

Codec Response for Other NID

| Bit | Description |
|------|-------------|
| 31:0 | 0's. |

8.37. Verb – Get Digital Converter Control 1 & Control 2 (Verb ID= F0Dh, F0Eh)

Table 72. Verb – Get Digital Converter Control 1 & Control 2 (Verb ID= F0Dh, F0Eh)

Get Command Format

| Bit [31:28] | Bit [27:20] | Bit [19:8] | Payload Bit [7:0] |
|-------------|-------------|-------------------|-------------------|
| CAd=X | Node ID=06h | Verb ID=F0Dh/F0Eh | 0's |

Codec Response Format

| Response [31:0] |
|---------------------------------------|
| Bit[31:16]=0's, Bit[15:0] are SIC bit |

NID=06h (SPDIF-OUT1 Converter) and 10h (SPDIF-OUT2 Converter) Response to 'Get verb' – F0Dh (Control for SIC bit[15:0])

| Bit | Description – SIC (SPDIF IEC Control) Bit[7:0] |
|-------|--|
| 31:16 | Read as 0's. |
| 15 | Reserved. Read as 0's. |
| 14:8 | CC[6:0] (Category Code). |
| 7 | LEVEL (Generation Level). |
| 6 | PRO (Professional or Consumer Format). 0: Consumer format 1: Professional format |
| 5 | /AUDIO (Non-Audio Data Type). 0: PCM data 1: AC3 or other digital non-audio data |
| 4 | COPY (Copyright). 0: Asserted 1: Not asserted |
| 3 | PRE (Pre-Emphasis). 0: None 1: Filter pre-emphasis is 50/15 microseconds |
| 2 | VCFG for Validity Control (control V bit and data in Sub-Frame). |
| 1 | V for Validity Control (control V bit and data in Sub-Frame). |
| 0 | Digital Enable. DigEn. 0: OFF 1: ON |

Codec Response for Other NID

| Bit | Description |
|------|-------------|
| 31:0 | 0's |

8.38. Verb – Set Digital Converter Control 1 & Control 2 (Verb ID=70Dh, 70Eh)

Table 73. Verb – Set Digital Converter Control 1 & Control 2 (Verb ID=70Dh, 70Eh)

Set Command Format (Verb ID=70Dh, Set Control 1)

| Bit [31:28] | Bit [27:20] | Bit [19:8] | Payload Bit [7:0] |
|-------------|-------------|--------------|-------------------|
| CAd=X | Node ID=06h | Verb ID=70Dh | SIC [7:0] |

Codec Response Format

| Response [31:0] |
|-----------------|
| 0's |

Set Command Format (Verb ID=70Eh, Set Control 2)

| Bit [31:28] | Bit [27:20] | Bit [19:8] | Payload Bit [7:0] |
|-------------|-------------|--------------|-------------------|
| CAd=X | Node ID=06h | Verb ID=70Eh | SIC [15:8] |

Codec Response Format

| Response [31:0] |
|-----------------|
| 0's |

'Payload' in Set Control 1 for NID=06h (SPDIF-OUT1 Converter) and 10h (SPDIF-OUT2 Converter)

| Bit | Description – SIC (SPDIF IEC Control) Bit[7:0] |
|-----|--|
| 7 | LEVEL (Generation Level) |
| 6 | PRO (Professional or Consumer Format). 0: Consumer format 1: Professional format |
| 5 | /AUDIO (Non-Audio Data Type). 0: PCM data 1: AC3 or other digital non-audio data |
| 4 | COPY (Copyright). 0: Asserted 1: Not asserted |
| 3 | PRE (Pre-Emphasis). 0: None 1: Filter pre-emphasis is 50/15 microseconds |
| 2 | VCFG for Validity Control (control V bit and data in Sub-Frame). |
| 1 | V for Validity Control (control V bit and data in Sub-Frame). |
| 0 | Digital Enable. DigEn. 0: OFF 1: ON |

'Payload' in Set Control 2 for NID=06h (SPDIF-OUT1 Converter) and 10h (SPDIF-OUT2 Converter)

| Bit | Description – SIC (SPDIF IEC Control) Bit[7:0] |
|-----|--|
| 7 | Reserved. Read as 0's. |
| 6:0 | CC[6:0] (Category Code). |

8.39. Verb – Get Subsystem ID [31:0] (Verb ID=F20h/F21h/D22h/F23h)

32-bit Read/Write register for Audio Function Group (NID=01h)

Table 74. Verb – Get Subsystem ID [31:0] (Verb ID=F20h/F21h/F22h/F23h)

Get Command Format

| Bit [31:28] | Bit [27:20] | Bit [19:8] | Payload Bit [7:0] |
|-------------|-------------|--------------|-------------------|
| CAd = X | Node ID=01h | Verb ID=F20h | 0s |

Codec Response Format

| Response [31:0] |
|-----------------|
| 32-bit Response |

Codec Response for NID=01h

| Bit | Description |
|-------|-------------------------------------|
| 31:16 | Subsystem ID[23:8] (Default=10ECh). |
| 15:8 | Subsystem ID[7:0] (Default=02h). |
| 7:0 | Assembly ID[7:0] (Default=72h). |

8.40. Verb – Set Subsystem ID [31:0] (Verb ID=723h/722h/721h/720h for [31:24]/[23:16]/[15:8]/[7:0])

Table 75. Verb – Set Subsystem ID [31:0] (Verb ID=723h/722h/721h/720h for [31:24]/[23:16]/[15:8]/[7:0])

Set Command Format

| Bit [31:28] | Bit [27:20] | Bit [19:8] | Payload Bit [7:0] |
|-------------|-------------|-----------------------------------|-------------------|
| CAd = X | Node ID=01h | Verb ID=723h, 722h, 721h, 720h | Label [7:0] |

Codec Response Format

| Response [31:0] |
|------------------|
| 0s for all nodes |

Codec Response for all NID

| Bit | Description |
|------|-------------|
| 31:0 | 0s. |

8.41. Verb – Get/Set EAPD Control (Verb ID=F0Ch for Get, 70Ch for Set)

Table 76. Verb – Get EAPD Control (Verb ID=F0Ch)

Get Command Format (NID=14h and 15h)

| Bit [31:28] | Bit [27:20] | Bit [19:8] | Payload Bit [7:0] |
|-------------|-----------------|--------------|-------------------|
| CAd=X | Node ID=14h/15h | Verb ID=F0Ch | 0s |

Codec Response Format

| Response [31:0] |
|------------------------|
| Bit[1] is EAPD Control |

Codec Response for NID=14h (LOUT1, port-D) and 15h (LOUT2, port-A)

| Bit | Description |
|------|--|
| 31:3 | Reserved. |
| 2 | L-R Swap. The ALC272 does not support swapping left and right channels. Read as 0. |
| 1 | EAPD Value. 0: EAPD pin state is low 1: EAPD pin state is high |
| 0 | BTL Enable. The ALC272 does not support BTL output. Read as 0. |

Codec Response for Other NID

| Bit | Description |
|------|-------------|
| 31:0 | 0's. |

Table 77. Verb – Set EAPD Control (Verb ID=70Ch)

Set Command Format (NID=14h and 15h)

| Bit [31:28] | Bit [27:20] | Bit [19:8] | Payload Bit [7:0] |
|-------------|-----------------|--------------|------------------------|
| CAd=X | Node ID=14h/15h | Verb ID=70Ch | Bit[1] is EAPD Control |

Codec Response Format

| Response [31:0] |
|-----------------|
| 0s |

Payload in Set command for NID=14h (LOUT1, port-D) and 15h (LOUT2, port-A)

| Bit | Description |
|------|--|
| 31:3 | Reserved. |
| 2 | L-R Swap. The ALC272 does not support swapping left and right channels. Read as 0. |
| 1 | EAPD Value. 0: EAPD pin state is low 1: EAPD pin state is high. <i>Note: Only one physical logic for the EAPD signal.</i> |
| 0 | BTL Enable. The ALC272 does not support BTL output. Read as 0. |

Codec Response

| Bit | Description |
|------|-------------|
| 31:0 | 0's. |

8.42. Verb – Function Reset (Verb ID=7FFh)

Table 78. Verb – Function Reset (Verb ID=7FFh)

Command Format (NID=01h)

| Bit [31:28] | Bit [27:20] | Bit [19:8] | Payload Bit [7:0] |
|-------------|-------------|--------------|-------------------|
| CAd=X | Node ID=01h | Verb ID=7FFh | 0's |

Codec Response Format

| Response [31:0] |
|-----------------|
| 0's |

Codec Response

| Bit | Description |
|------|------------------------|
| 31:0 | Reserved. Read as 0's. |

Note: The Function Reset command causes all widgets to return to their power-on default state.

9. Electrical Characteristics

9.1. DC Characteristics

9.1.1. Absolute Maximum Ratings

Table 79. Absolute Maximum Ratings

| Parameter | Symbol | Minimum | Typical | Maximum | Units |
|--------------------------------------|----------|------------------------|---------|---------|-------|
| Power Supply | | | | | |
| Digital Power for Core | DVDD | 2.7 | 3.3 | 3.6 | V |
| Digital Power for HDA Link | DVDD-IO* | 1.5 | 3.3 | 3.6 | V |
| Analog | AVDD** | 3.0 | 5.0 | 5.5 | V |
| Ambient Operating Temperature | Ta | 0 | - | +70 | °C |
| Storage Temperature | Ts | - | - | +125 | °C |
| ESD (Electrostatic Discharge) | | | | | |
| | | Susceptibility Voltage | | | |
| All Pins | | Pass 3500V | | | |

*: The digital link power DVDD-IO must be lower than the digital core power DVDD.

** : The standard testing condition before shipping is AVDD = 5.0V unless specified. Customers designing with a different AVDD should contact Realtek technical support representatives for special testing support.

9.1.2. Threshold Voltage

DVDD=3.3V±5%, T_{ambient}=25°C, with 50pF external load.

Table 80. Threshold Voltage

| Parameter | Symbol | Minimum | Typical | Maximum | Units |
|--------------------------------------|-----------------|------------------|---------|------------------|-------|
| Input Voltage Range | V _{in} | -0.30 | - | DVDD+0.30 | V |
| Low Level Input Voltage (HDA Link) | V _{IL} | - | - | 0.30*DVDDIO | V |
| High Level Input Voltage (HDA Link) | V _{IH} | 0.65*DVDDIO | - | - | V |
| Low Level Input Voltage (SPDIF-OUT) | V _{IL} | - | - | 0.44*DVDD (1.45) | V |
| High Level Input Voltage (SPDIF-OUT) | V _{IH} | 0.56*DVDD (1.85) | - | - | V |
| High Level Output Voltage | V _{OH} | 0.9*DVDD | - | - | V |
| Low Level Output Voltage | V _{OL} | - | - | 0.1*DVDD | V |
| Input Leakage Current | - | -10 | - | 10 | μA |
| Output Leakage Current (Hi-Z) | - | -10 | - | 10 | μA |
| Output Buffer Drive Current | - | - | 5 | - | mA |
| Internal Pull Up Resistance | - | - | 50k | 100k | Ω |

9.1.3. SPDIF Output Characteristics

DVDD= 3.3V, $T_{\text{ambient}}=25^{\circ}\text{C}$, with 75Ω external load.

Table 81. SPDIF Output Characteristics

| Parameter | Symbol | Minimum | Typical | Maximum | Units |
|-----------------------------|-----------------|---------|---------|---------|-------|
| SPDIF-OUT High Level Output | V_{OH} | 3.0 | 3.3 | - | V |
| SPDIF-OUT Low Level Output | V_{OL} | - | 0 | 0.3 | V |

9.1.4. Digital Filter Characteristics

Table 82. Digital Filter Characteristics

| Filter | Symbol | Minimum | Typical | Maximum | Units |
|--------------------|-----------------------------|------------------|-------------|------------------|-------|
| ADC Lowpass Filter | Passband | 0 | - | $0.45 \cdot F_s$ | kHz |
| | Stopband | $0.60 \cdot F_s$ | - | - | kHz |
| | Stopband Rejection | - | -76.0 | - | dB |
| | Passband Frequency Response | - | ± 0.02 | - | dB |
| DAC Lowpass Filter | Passband | 0 | - | $0.45 \cdot F_s$ | kHz |
| | Stopband | $0.60 \cdot F_s$ | - | - | kHz |
| | Stopband Rejection | - | -78.5 | - | dB |
| | Passband Frequency Response | - | ± 0.020 | - | dB |

Note: F_s =Sample rate.

9.2. AC Characteristics

9.2.1. Link Reset and Initialization Timing

Table 83. Link Reset and Initialization Timing

| Parameter | Symbol | Minimum | Typical | Maximum | Units |
|--|-------------|---------|---------|---------|------------|
| RESET# Active Low Pulse Width | T_{RST} | 1.0 | - | - | μ s |
| RESET# Inactive to BCLK Startup Delay for PLL Ready Time | T_{PLL} | 20 | - | - | μ s |
| SDI Initialization Request | T_{FRAME} | - | - | 1 | Frame Time |

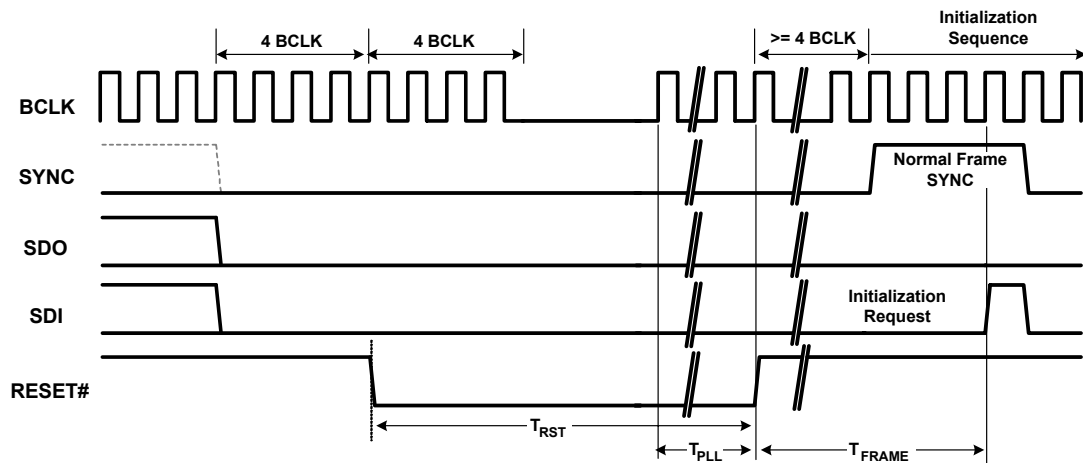
Figure 15. Link Reset and Initialization Timing

9.2.2. Link Timing Parameters at the Codec

Table 84. Link Timing Parameters at the Codec

| Parameter | Symbol | Minimum | Typical | Maximum | Units |
|--|---------------------|-------------|---------|-------------|--------|
| BCLK Frequency | - | - | 24.0 | - | MHz |
| BCLK Period | T_{cycle} | - | 41.67 | - | ns |
| BCLK Jitter | T_{jitter} | - | - | 2.0 | ns |
| BCLK High Pulse Width | T_{high} | 18.75 (45%) | - | 22.91 (55%) | ns (%) |
| BCLK Low Pulse Width | T_{low} | 18.75 (45%) | - | 22.91 (55%) | ns (%) |
| SDO Setup Time at Both Rising and Falling Edge of BCLK | T_{setup} | 2.1 | - | - | ns |
| SDO Hold Time at Both Rising and Falling Edge of BCLK | T_{hold} | 2.1 | - | - | ns |
| SDI Valid Time After Rising Edge of BCLK (1: 50pF external load) | T_{tco} | - | 7.5 | 8.0 | ns |
| SDI Flight Time | T_{flight} | - | 2.0 | - | ns |

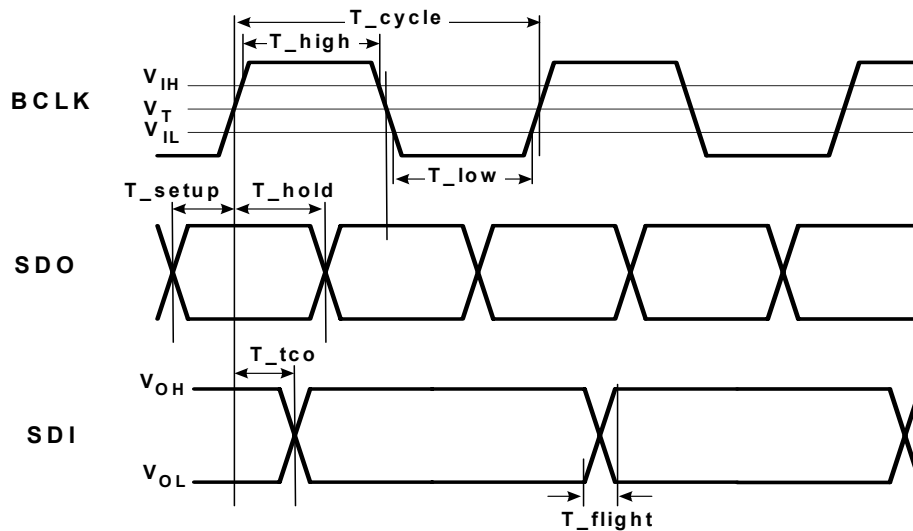
Figure 16. Link Signal Timing

9.2.3. SPDIF Output Timing

Table 85. SPDIF Output Timing

| Parameter | Symbol | Minimum | Typical | Maximum | Units |
|----------------------------|---------------------|-------------|-------------|-------------|--------|
| SPDIF-OUT Frequency | - | - | 3.072 | - | MHz |
| SPDIF-OUT Period | T_{cycle} | - | 325.6 | - | ns |
| SPDIF-OUT Jitter | T_{jitter} | - | - | 4 | ns |
| SPDIF-OUT High Level Width | T_{High} | 156.2 (48%) | 162.8 (50%) | 169.2 (52%) | ns (%) |
| SPDIF-OUT Low Level Width | T_{Low} | 156.2 (48%) | 162.8 (50%) | 169.2 (52%) | ns (%) |
| SPDIF-OUT Rising Time | T_{rise} | - | 2.0 | - | ns |
| SPDIF-OUT Falling Time | T_{fall} | - | 2.0 | - | ns |

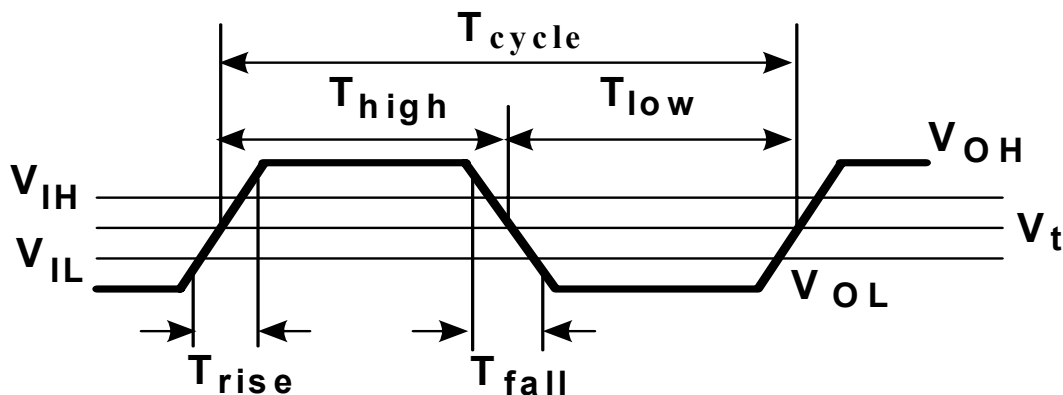
Figure 17. Output Timing

9.2.4. Test Mode

Codec test mode and Automatic Test Equipment (ATE) mode are not supported.

9.3. Analog Performance

- Standard Test Conditions
- $T_{\text{ambient}}=25^{\circ}\text{C}$, $\text{DVDD}=3.3\text{V}\pm 5\%$, $\text{AVDD}=5.0\text{V}\pm 5\%$
 - 1kHz input sine wave; Sampling frequency=48kHz; 0dB=1Vrms
 - 10K Ω /50pF load; Test bench Characterization BW: 10Hz~22kHz

Table 86. Analog Performance

| Parameter | Min | Typ | Max | Units |
|---|-------|---------|----------|------------|
| Full-Scale Input Voltage | | | | |
| Analog Input (Gain=0dB) | - | 1.6 | - | Vrms |
| ADC | - | 1.4 | - | Vrms |
| Full-Scale Output Voltage | | | | |
| DAC | - | 1.1 | - | Vrms |
| S/N (A Weighted) | | | | |
| ADC | - | 90 | - | dB FSA |
| DAC | - | 95 | - | dB FSA |
| Headphone Amplifier | - | 95 | - | dBFS A |
| THD+N | | | | |
| ADC | - | -80 | - | dB FS |
| DAC | - | -87 | - | dB FS |
| Headphone Amplifier (32 Ω Load) | - | -75 | - | dB FS |
| Magnitude Response | | | | |
| ADC (-3dB lower edge, -1dB higher edge)* ¹ | 10 | - | > 20,000 | Hz |
| DAC (-3dB lower edge, -1dB higher edge)* ¹ | 10 | - | > 20,000 | Hz |
| Pass Band Ripple for DAC and ADC | -0.02 | - | +0.02 | dB |
| Power Supply Rejection Ratio | - | -60 | - | dB |
| Total Out-of-Band Noise (28.8kHz~100kHz) | - | -60 | - | dB |
| Crosstalk Between Output Channel | - | -80 | - | dB |
| Output Noise Level During System Activity | - | - | 110 | dB |
| Output Inter-Channel Phase Delay | - | - | 0.2 | Degree |
| Input Impedance (Gain=0dB) | - | 32 | - | K Ω |
| Output Impedance | | | | |
| Line Output | - | 100 | - | Ω |
| Amplified Output | - | 1 | 2 | Ω |
| Power Supply Current (Normal Operation) | - | 45/25 | - | mA |
| AVDD=5V/DVDD=3.3V | | | | |
| Power Supply Current (Power Down Mode) | - | 1.5/0.4 | - | mA |
| AVDD=5V/DVDD=3.3V | | | | |
| VREFOUTx Output Voltage (AVDD=5.0V) | - | 2.5 | 3.2 | V |
| VREFOUTx Output Current (AVDD=5.0V) | - | 5 | - | mA |

*1: The higher edge of magnitudes for DAC and ADC are -0.6dB@20,000Hz.

10. Application Circuits

The ALC272 is NOT pin compatible with the ALC662, ALC88x, and ALC26x series HD Audio Codecs. To get the best compatibility in hardware design and software driver, any modification should be confirmed by Realtek. Realtek may upload the latest application circuits onto our website (www.realtek.com.tw) without modifying this datasheet.

10.1. Filter Connection

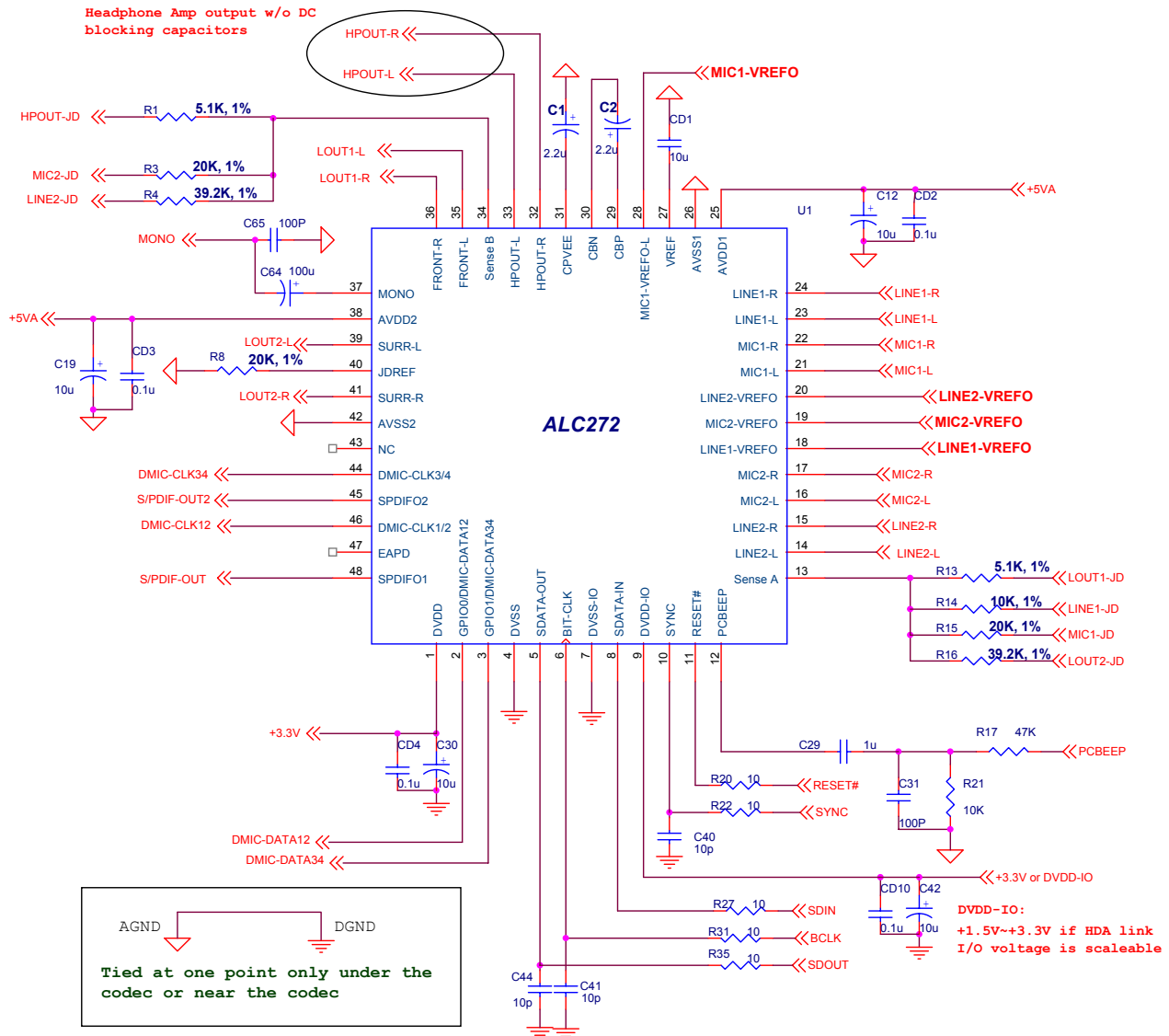

10.2. Onboard Front Panel Header Connection and Front Panel I/O

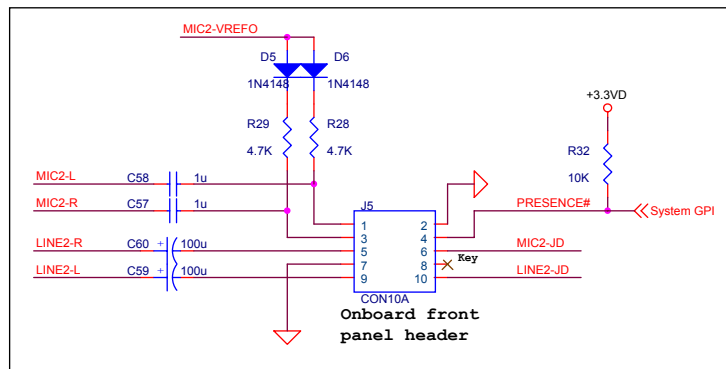
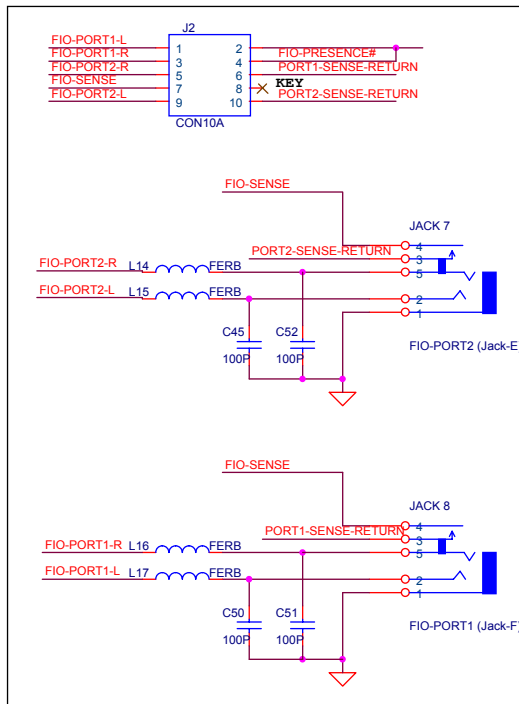
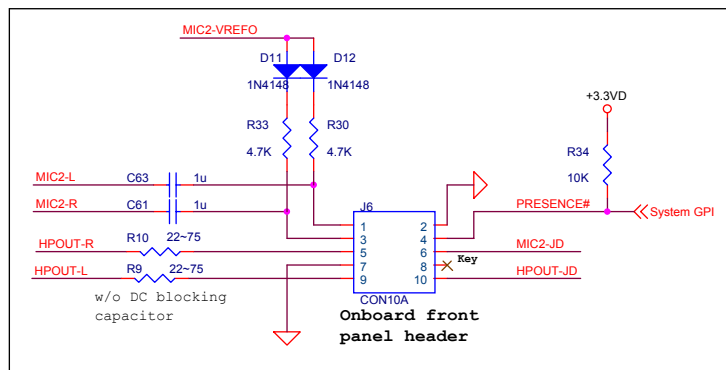
Option 1: MIC2 (port-F) and LINE2 (port-E) to front panel header

HD Audio Front Panel I/O Cable

Option 2: MIC2 (port-F) and HP-OUT (port-I) to front panel header

Figure 19. Onboard Front Panel Header Connection and Front Panel I/O

10.3. Power Supply and Analog Input/Output Connection

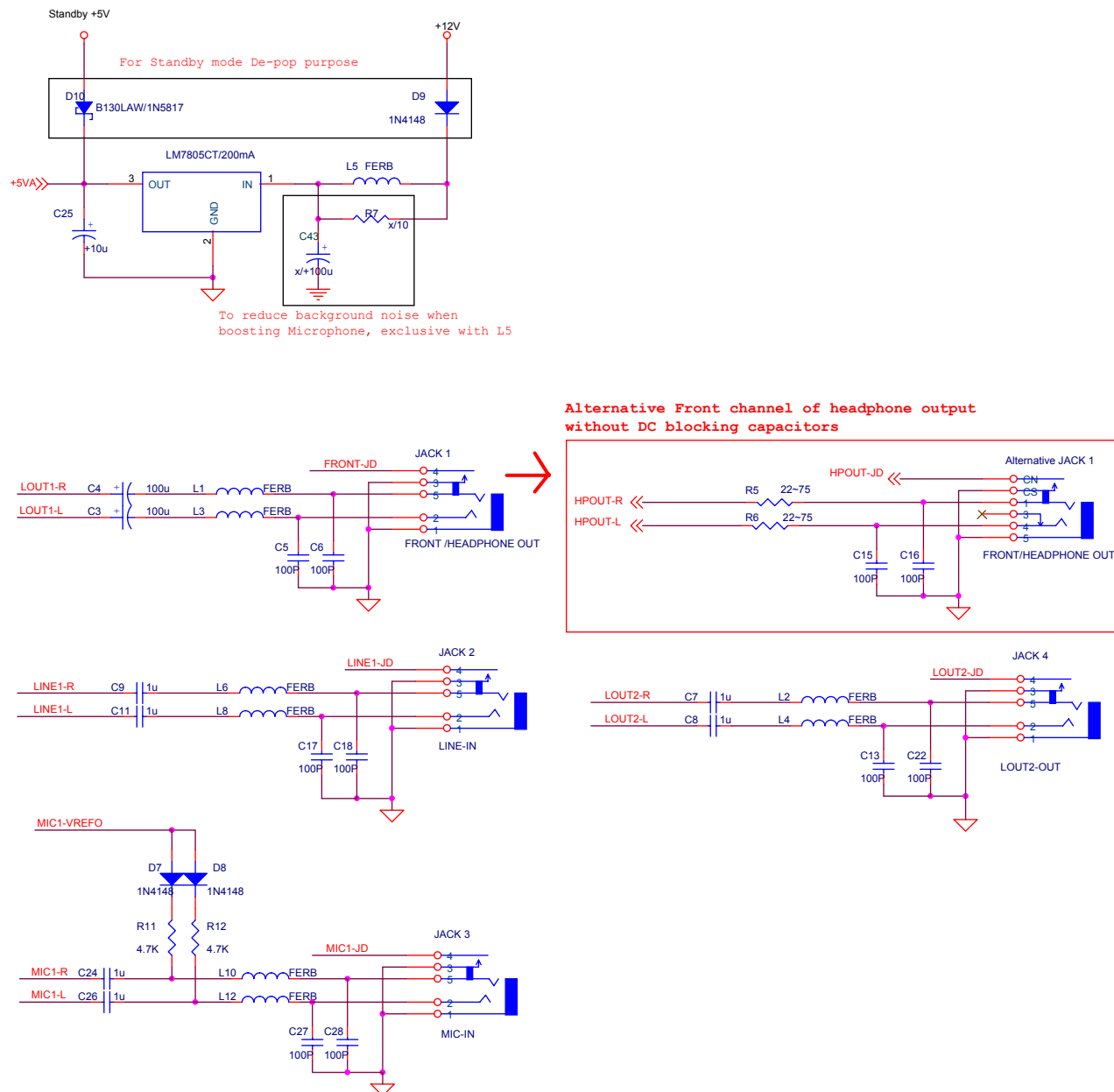
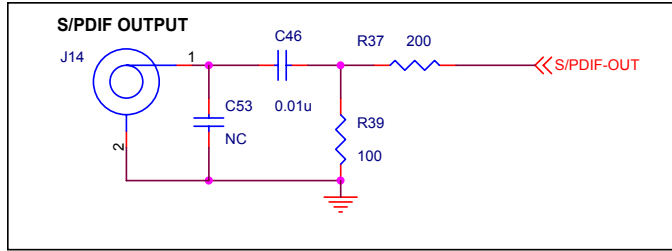

Figure 20. Analog Input/Output Connection

10.4. Optional SPDIF Output

S/PDIF Output Connection option 1: Coaxial



S/PDIF OutputConnection option 2: Optical

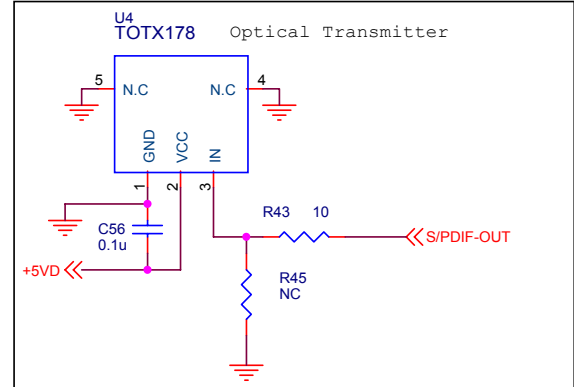
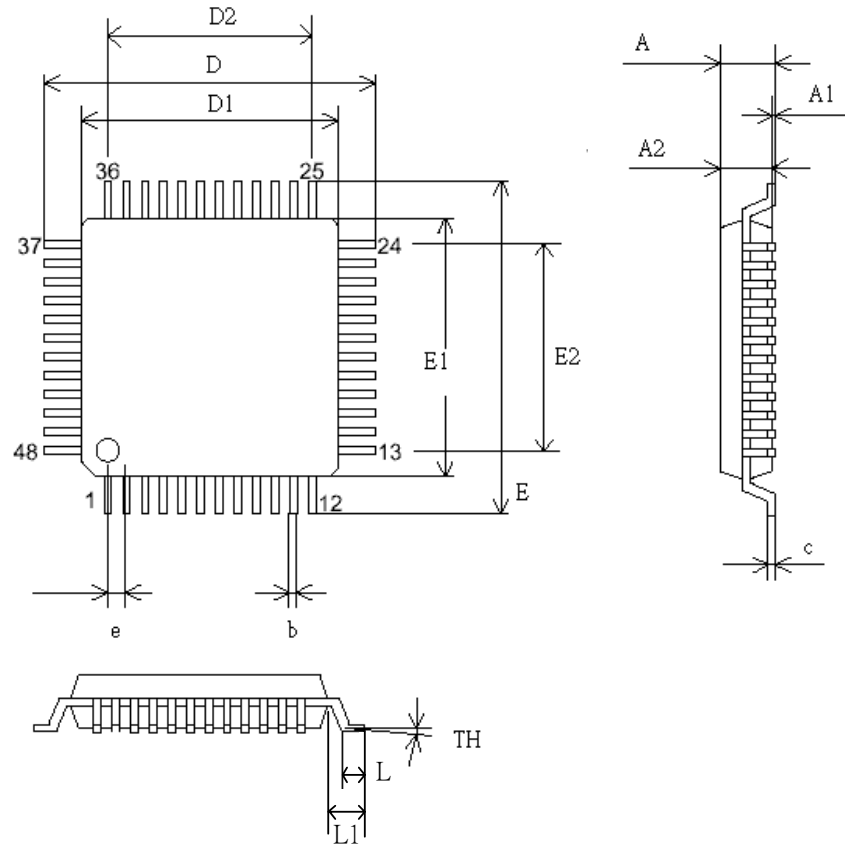

Figure 21. Optional SPDIF Output

11. Mechanical Dimensions



| SYMBOL | MILLIMETER | | | INCH | | |
|--------|------------|------|------|------------|--------|-------|
| | MIN | TYP | MAX | MIN | TYP | MAX |
| A | - | - | 1.60 | - | - | 0.063 |
| A1 | 0.05 | - | 0.15 | 0.002 | - | 0.006 |
| A2 | 1.35 | 1.40 | 1.45 | 0.053 | 0.055 | 0.057 |
| c | 0.09 | - | 0.20 | 0.004 | - | 0.008 |
| D | 9.00 BSC | | | 0.354 BSC | | |
| D1 | 7.00 BSC | | | 0.276 BSC | | |
| D2 | 5.50 | | | 0.217 | | |
| E | 9.00 BSC | | | 0.354 BSC | | |
| E1 | 7.00 BSC | | | 0.276 BSC | | |
| E2 | 5.50 | | | 0.217 | | |
| b | 0.17 | 0.20 | 0.27 | 0.007 | 0.008 | 0.011 |
| e | 0.50 BSC | | | 0.0196 BSC | | |
| TH | 0° | 3.5° | 7° | 0° | 3.5° | 7° |
| L | 0.45 | 0.60 | 0.75 | 0.018 | 0.0236 | 0.030 |
| L1 | - | 1.00 | - | - | 0.0393 | - |

| | | | |
|---|--|----------|---------|
| TITLE: LQFP-48 (7.0x7.0x1.6mm) | | | |
| PACKAGE OUTLINE DRAWING, FOOTPRINT 2.0mm | | | |
| LEADFRAME MATERIAL | | | |
| APPROVE | | DOC. NO. | |
| | | VERSION | 02 |
| CHECK | | DWG NO. | PKG-065 |
| | | DATE | |
| REALTEK SEMICONDUCTOR CORP. | | | |

12. Ordering Information

Table 87. Ordering Information

| Part Number | Package | Status |
|-------------|-------------------------|-----------------|
| ALC272-GR | LQFP-48 'Green' Package | Mass Production |

Note 1: See page 6 for Green package and version identification.

Note 2: Above parts are tested under AVDD=5.0V. If customers have lower AVDD request, please contact Realtek sales representatives or agents.

Realtek Semiconductor Corp.**Headquarters**

No. 2, Innovation Road II
Hsinchu Science Park, Hsinchu 300, Taiwan
Tel.: +886-3-578-0211. Fax: +886-3-577-6047
www.realtek.com.tw