

Video Output

**Description**

CX20095A is a bipolar IC designed as a driver of 75 Ω line (transmission and receiving line) used in the video signal system. It is comprised of a 75 Ω line drive, receiving amplifier and 6 dB amplifier for multi-purpose applications.

**Features**

- Low power supply voltage operation,  $V_{CC} = 5V$  (Typ.)
- Transmission/Receiving amplifier has a built-in sync chip clamp.
- Bilateral communication configuration is possible with one line.
- Driver amplifier and 6dB amplifier are provided with power-saving function.
- Simple superimpose is possible with the trans amplifier.

**Structure**

Bipolar silicon monolithic IC

**Absolute Maximum Ratings ( $T_a = 25^\circ C$ )**

• Supply voltage	$V_{CC}$	17	V
• Operating temperature	$T_{opr}$	- 10 to + 65	°C
• Storage temperature	$T_{stg}$	- 55 to + 150	°C
• Allowable power dissipation	PD	500	mW

**Recommended Operating Condition**

• Supply voltage	$V_{CC}$	4.8 to 5.2	V
------------------	----------	------------	---

**Package Outline**

Unit: mm

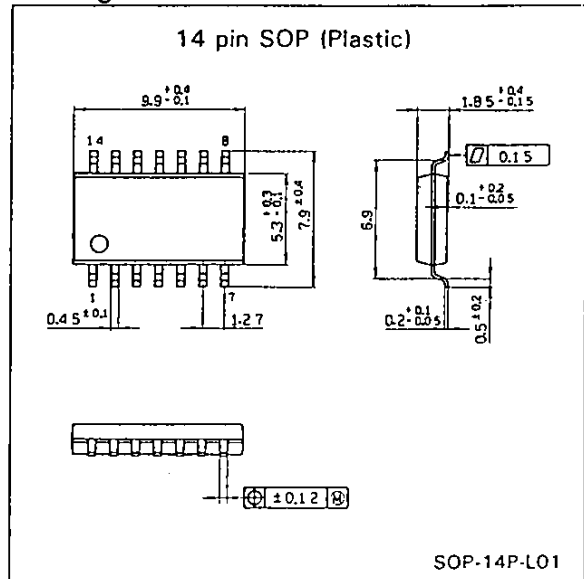

Block Diagram and Pin Configuration (Top view)

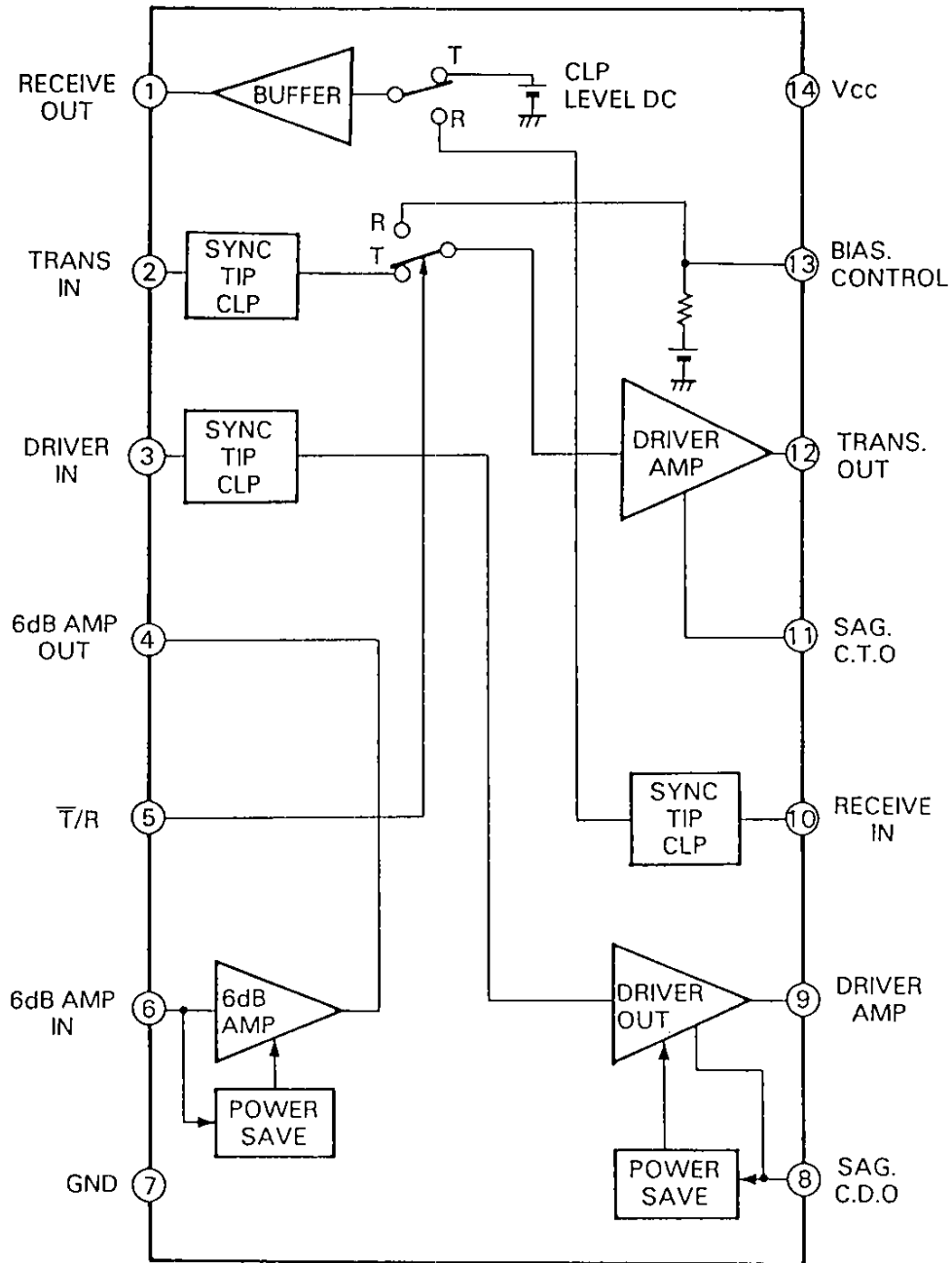

## Pin Description

(See the Electrical Characteristics Test Circuit)  
DC voltage when no signal is input,  $T_a = 25^\circ\text{C}$ .

No.	Name	Voltage (V) standard value	Description
1	RECEIVE OUT	1.65	When pin 5 is at "H", the signal input from pin 10 is output with gain 0 dB. DC is output when pin 5 is at "L".
2	TRANS IN	1.28	Trans amplifier input: As sync chip clamp may result, a low impedance input is required.
3	DRIVER IN	1.28	Drive amplifier input: As sync chip clamp may result, a low impedance input is required.
4	6 dB AMP OUT	2.35	The signal input from pin 6 is output with gain 6 dB.
5	T/R	0	Mode switching pin Trans/Receive: Receive mode at "H" (over 4V) and Trans mode at "L" (less than 1V).
6	6 dB AMP IN	2.45	6 dB amplifier input: Input impedance more than approx. 10 k $\Omega$ , DC 2.4V
7	GND	0	
8	SAG.C.D.O.	1.29	The pin 9 sag is corrected by adding the sag component in the pin 9 output. Refer to Electrical Characteristics Test Circuit.
9	DRIVER OUT	1.08	Driver amplifier output: 75 $\Omega$ line drive is output. The signal input from pin 3 is output with gain 6 dB.
10	RECEIVE IN	1.74	Receiving amplifier input: As sync chip clamp may result, a low impedance input is required.
11	SAG.C.T.O.	1.30	The pin 12 sag is corrected by adding the sag component in the pin 12 output. Refer to Electrical Characteristics Test Circuit.
12	TRANS. OUT	1.10	Trans amplifier output: The signal input from pin 2 when pin 5 is at "L" is output to the 75 $\Omega$ line with a gain of 6 dB. A DC voltage determined at pin 13 is output when pin 5 is at "H".
13	BIAS. CONTROL	2.13	When pin 5 is at "H", its voltage is varied to vary the pin 12 output (DC) in turn. By linking with pin 5, simple superimpose can be possible in the pin 12 output. (In this case, the pin 1 output is affected.)
14	Vcc	5.0	+ 5.0V

Electrical Characteristics

Ta = 25°C, Vcc = 5.0V, See the Electrical Characteristics Test Circuit

No.	Test item	Test Point	Input condition	Test condition														Remark	Test symbol	Min.	Typ.	Max.	Unit
				1	2	3	4	5	6	7	8	9	10	11	12	13	14						
1	Consumption current	I																7.5	11	15	mA		
2	Power saving	I							ON	ON								4.5	6.5	9	mA		
3	Trans amp gain	V	500kHz, 1Vp-p		ON				ON									-0.5	0	+0.5	dB		
4	Trans dynamic range	V	16kHz, Square wave		ON				ON									1.4			Vp-p		
5-a	Trans bias control	V									ON							2.0	2.15	2.3	V		
5-b	Trans bias control	V										ON	ON					2.65	2.75	2.9	V		
5-c	Trans bias control	V	Ez = 2.3V										ON	ON	ON								
6	Receiver amp gain	V	500kHz, 1Vp-p			ON												5.3	6.0	6.8	dB		
7	Receiver dynamic range	V	16kHz, Square wave			ON																	
8	Driver amp gain	V	500kHz, 1Vp-p	ON						ON													
9	Driver dynamic range	V	16kHz, Square wave	ON						ON													
10	6dB amp gain	V	500kHz, 1Vp-p				ON																
11	6dB dynamic range	V	16kHz, 1.4Vp-p Square wave				ON			ON													
12	Trans receiver leakage	V	4MHz 0.7Vp-p			ON																	

Electrical Characteristics Test Circuit

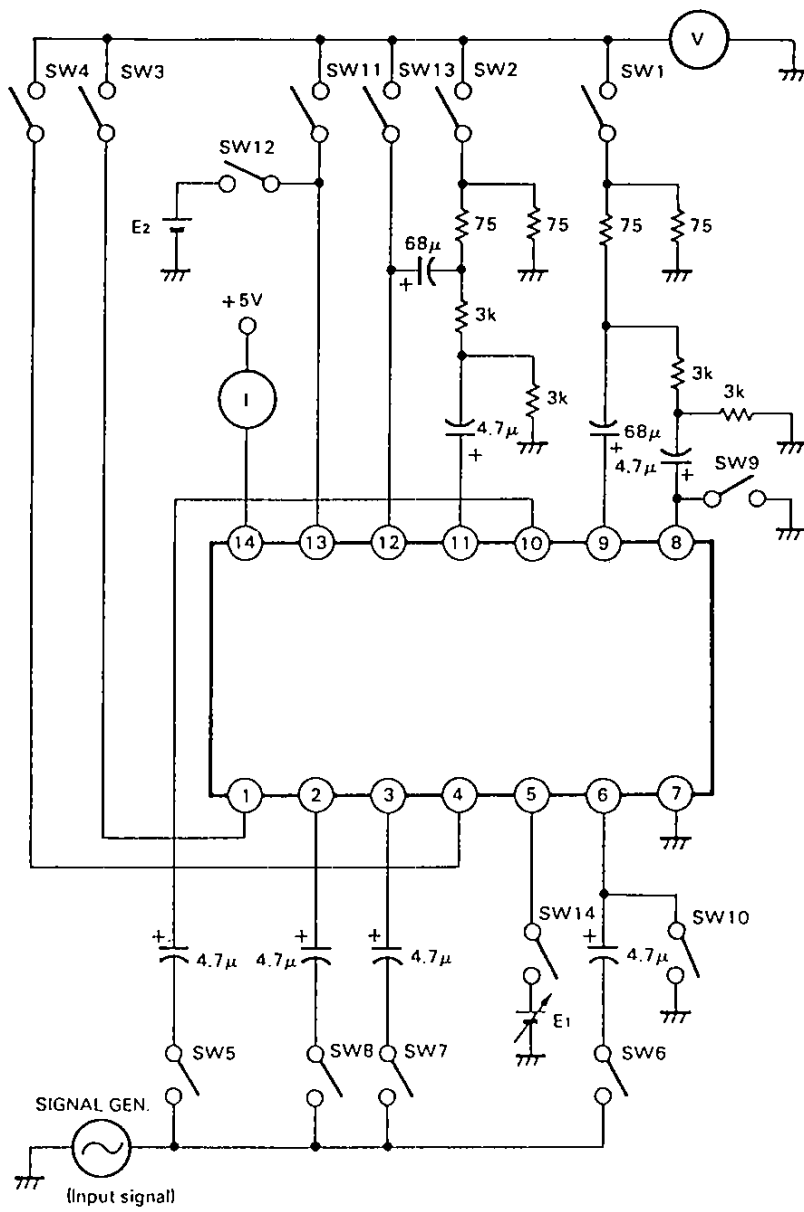

Application Circuit

Transmission and receiving reference circuit (Trans amplifier, Receive amplifier)

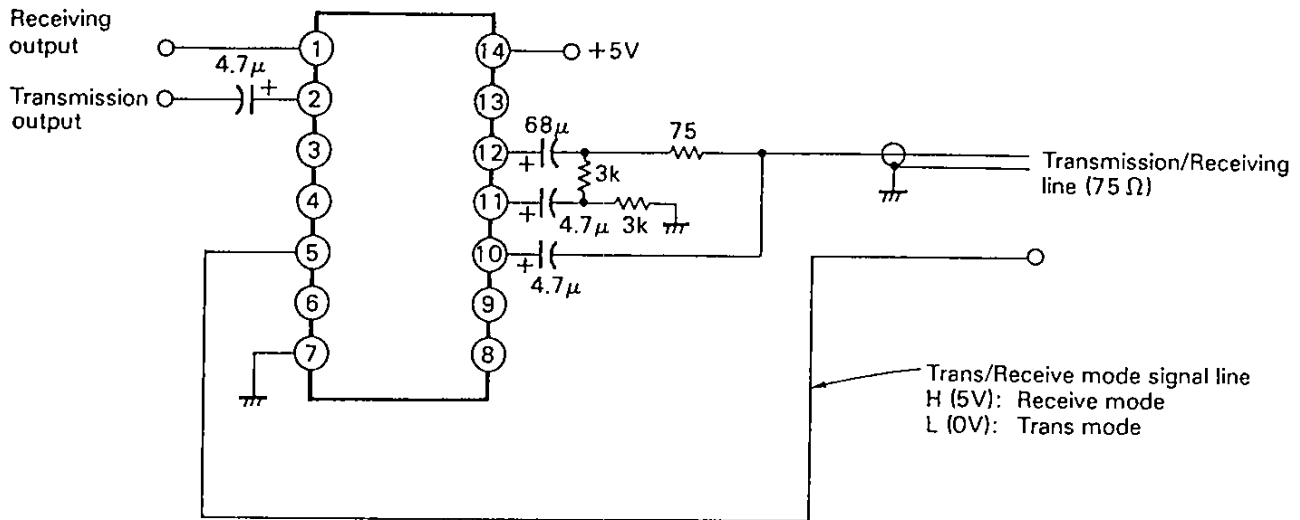

Driver amplifier, 6 dB amplifier external reference circuit

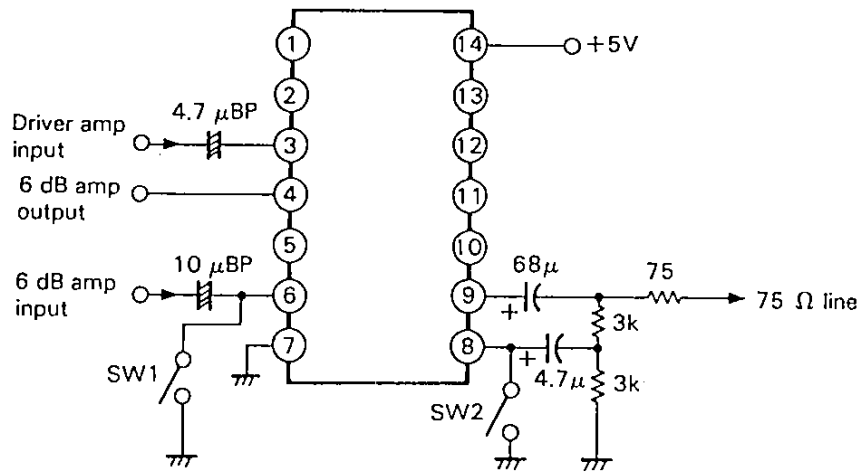

SW1: 6 dB amp power saving mode when switched on.  
 SW2: Driver amp power saving mode when switched on.

Trans amplifier gain vs. Ambient temperature

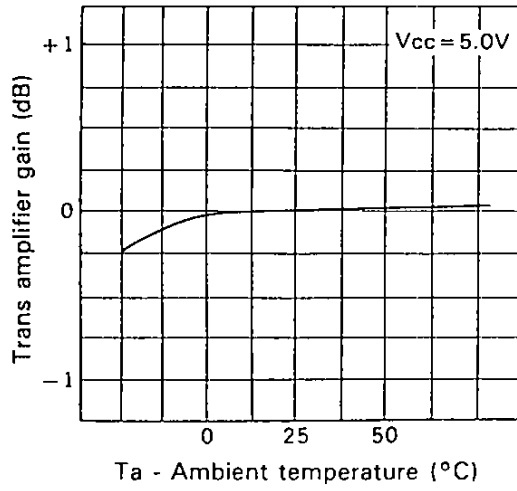

Driver amplifier gain vs. Ambient temperature

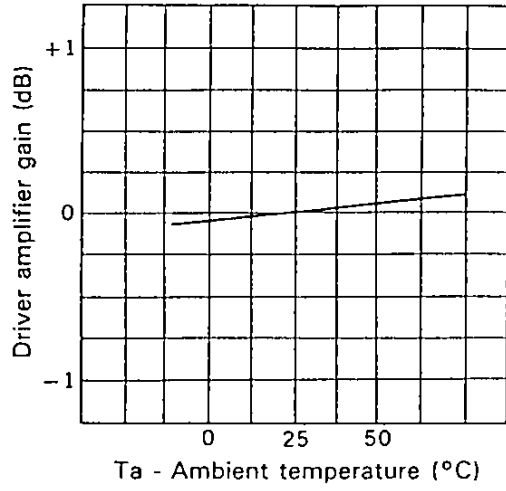

Receive amplifier vs. Ambient temperature

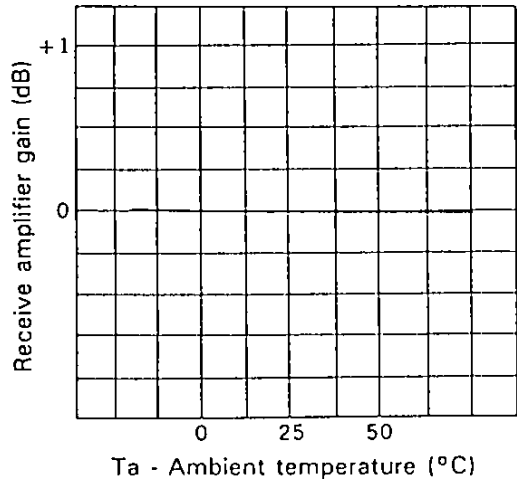

6 dB amplifier gain vs. Ambient temperature

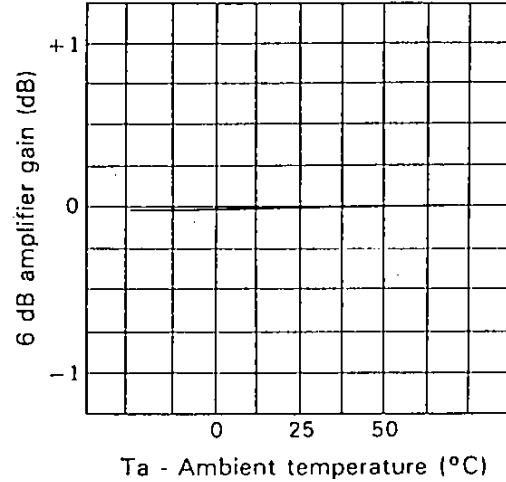

Note) Gain at 25°C is assumed to be 0 dB.