

Revision History

Revision	Date	Description
A	July 31, 2009	Initial release

© 2009, Conexant Systems, Inc.
All Rights Reserved.

Information in this document is provided in connection with Conexant Systems, Inc. ("Conexant") products. These materials are provided by Conexant as a service to its customers and may be used for informational purposes only. Conexant assumes no responsibility for errors or omissions in these materials. Conexant may make changes to this document at any time, without notice. Conexant advises all customers to ensure that they have the latest version of this document and to verify, before placing orders, that information being relied on is current and complete. Conexant makes no commitment to update the information and shall have no responsibility whatsoever for conflicts or incompatibilities arising from future changes to its specifications and product descriptions.

No license, express or implied, by estoppel or otherwise, to any intellectual property rights is granted by this document. Except as provided in Conexant's Terms and Conditions of Sale for such products, Conexant assumes no liability whatsoever.

THESE MATERIALS ARE PROVIDED "AS IS" WITHOUT WARRANTY OF ANY KIND, EITHER EXPRESS OR IMPLIED, RELATING TO SALE AND/OR USE OF CONEXANT PRODUCTS INCLUDING LIABILITY OR WARRANTIES RELATING TO FITNESS FOR A PARTICULAR PURPOSE, CONSEQUENTIAL OR INCIDENTAL DAMAGES, MERCHANTABILITY, OR INFRINGEMENT OF ANY PATENT, COPYRIGHT OR OTHER INTELLECTUAL PROPERTY RIGHT. CONEXANT FURTHER DOES NOT WARRANT THE ACCURACY OR COMPLETENESS OF THE INFORMATION, TEXT, GRAPHICS OR OTHER ITEMS CONTAINED WITHIN THESE MATERIALS. CONEXANT SHALL NOT BE LIABLE FOR ANY SPECIAL, INDIRECT, INCIDENTAL, OR CONSEQUENTIAL DAMAGES, INCLUDING WITHOUT LIMITATION, LOST REVENUES OR LOST PROFITS, WHICH MAY RESULT FROM THE USE OF THESE MATERIALS.

Conexant products are not intended for use in medical, lifesaving or life sustaining applications. Conexant customers using or selling Conexant products for use in such applications do so at their own risk and agree to fully indemnify Conexant for any damages resulting from such improper use or sale.

The following are trademarks of Conexant Systems, Inc.: Conexant® and the Conexant C symbol. Product names or services listed in this publication are for identification purposes only, and may be trademarks of third parties. Third-party brands and names are the property of their respective owners.

For additional disclaimer information, please consult Conexant's Legal Information posted at www.conexant.com which is incorporated by reference.

Conexant Lead-free products are China RoHS Compliant: 

Reader Response: Conexant strives to produce quality documentation and welcomes your feedback. Please send comments and suggestions to tech.pubs@conexant.com. For technical questions, contact your local Conexant sales office or field applications engineer.

Contents

Figures	7
Tables	9
1 Introduction	11
1.1 Overview	11
1.2 Applications	12
1.3 Features	14
1.3.1 General Modem Features	14
1.4 Technical Overview	16
1.4.1 General Description	16
1.4.2 MCU Firmware	16
1.4.3 Operating Modes	17
1.4.3.1 Data/Fax Modes	17
1.4.3.2 V.44 Data Compression	17
1.4.3.3 Country Support	18
1.4.3.4 TAM Mode	18
1.4.3.5 Speakerphone Mode (S Models)	20
1.4.4 Reference Designs	20
1.5 Hardware Description	20
1.5.1 CX06833 Modem Device	20
1.5.2 CX20452 Voice Codec	21
1.6 AT Commands	21
2 Technical Specifications	23
2.1 Serial DTE Interface Operation	23
2.1.1 Automatic Speed/Format Sensing	23
2.1.1.1 Command Mode and Data Mode	23
2.1.1.2 Fax Mode	23
2.2 Parallel Host Bus Interface Operation	24
2.3 Establishing Data Modem Connections	24
2.3.1 Dialing	24
2.3.2 Telephone Number Directory	24
2.3.3 Modem Handshaking Protocol	24
2.3.4 Call Progress Tone Detection	24
2.3.5 Answer Tone Detection	24
2.3.6 Ring Detection	25

2.3.7	Billing Protection	25
2.3.8	Connection Speeds	25
2.3.9	Automode	25
2.4	Data Mode	26
2.4.1	Speed Buffering (Normal Mode)	26
2.4.2	Flow Control	26
2.4.3	Escape Sequence Detection	26
2.4.4	BREAK Detection	26
2.4.5	Telephone Line Monitoring	26
2.4.6	Fall Forward/Fallback (V.92/V.90/V.34/V.32 bis/V.32)	26
2.4.7	Retrain	27
2.4.8	Programmable Inactivity Timer	27
2.4.9	DTE Signal Monitoring (Serial DTE Interface Only)	27
2.5	V.92 Features	28
2.5.1	Modem-on-Hold	28
2.5.2	Quick Connect	28
2.5.3	PCM Upstream	28
2.6	Error Correction and Data Compression	29
2.6.1	V.42 Error Correction	29
2.6.2	MNP 2-4 Error Correction	29
2.6.3	V.44 Data Compression	29
2.6.4	V.42 bis Data Compression	29
2.6.5	MNP 5 Data Compression	29
2.7	Telephony Extensions	30
2.7.1	Line In Use Detection	30
2.7.2	Extension Pickup Detection	30
2.7.3	Remote Hang-up Detection	30
2.8	Fax Class 1 and Fax Class 1.0 Operation	31
2.9	Point-of-Sales Support	31
2.10	Voice/Audio Mode	31
2.10.1	Online Voice Command Mode	31
2.10.2	Voice Receive Mode	31
2.10.3	Voice Transmit Mode	32
2.10.4	Full-Duplex Receive and Transmit Mode	32
2.10.5	Audio Mode	32
2.10.6	Tone Detectors	32
2.10.7	Speakerphone Mode	32
2.11	V.80 Synchronous Access Mode (SAM) - Video Conferencing	33
2.12	Full-Duplex Speakerphone (FDSP) Mode (S Models)	33
2.13	Caller ID	33
2.14	Worldwide Country Support	34
2.15	Diagnostics	35
2.15.1	Commanded Tests	35
2.15.2	Power On Reset Tests	35
2.16	Low Power Sleep Mode	36
3	Hardware Interface	37
3.1	CX06833 Hardware Pins and Signals	37

3.1.1	CX06833 Interface Signals	37
3.2	CX20452 VC Hardware Pins and Signals (S Models)	58
3.2.1	CX20452 VC Signal Summary	58
3.2.1.1	Speakerphone Interface	58
3.2.1.2	Telephone Handset/Headset Interface	58
3.2.1.3	CX06833 Modem Interface	58
3.2.1.4	Host Interface	58
3.2.2	CX20452 VC Pin Assignments and Signal Definitions	59
3.3	Electrical and Environmental Specifications	65
3.3.1	Operating Conditions, Absolute Maximum Ratings, and Power Requirements	65
3.3.1.1	Handling CMOS Devices	66
3.4	Interface and Timing Waveforms	67
3.4.1	External Memory Bus Timing	67
3.4.2	Parallel Host Bus Timing	69
3.4.3	Serial DTE Interface	71
3.5	Crystal Specifications	72
4	Package Dimensions	73
5	Parallel Host Interface	75
5.1	Overview	75
5.2	Register Signal Definitions	77
5.2.1	IER - Interrupt Enable Register (Addr = 1, DLAB = 0)	77
5.2.2	FCR - FIFO Control Register (Addr = 2, Write Only)	78
5.2.3	IIR - Interrupt Identifier Register (Addr = 2)	79
5.2.4	LCR - Line Control Register (Addr = 3)	81
5.2.5	MCR - Modem Control Register (Addr = 4)	82
5.2.6	LSR - Line Status Register (Addr = 5)	83
5.2.7	MSR - Modem Status Register (Addr = 6)	84
5.2.8	RBR - RX Buffer (Receiver Buffer Register) (Addr = 0, DLAB = 0)	85
5.2.9	THR - TX Buffer (Transmitter Holding Register) (Addr = 0, DLAB = 0)	85
5.2.10	Divisor Registers (Addr = 0 and 1, DLAB = 1)	85
5.2.11	SCR - Scratch Register (Addr = 7)	86
5.3	Receiver FIFO Interrupt Operation	86
5.3.1	Receiver Data Available Interrupt	86
5.3.2	Receiver Character Time-out Interrupts	86
5.4	Transmitter FIFO Interrupt Operation	86
5.4.1	Transmitter Empty Interrupt	86

Figures

Figure 1.	SMXXD Modem Simplified Interface Diagram	13
Figure 2.	SMXXD Modem Major Interfaces	13
Figure 3.	TMIND# Test Results Pulse Cycles	35
Figure 4.	CX06833 Hardware Signals for Parallel Interface (PARIF = High)	38
Figure 5.	CX06833 144-Pin TQFP Pin Signals for Parallel Interface (PARIF = High)	39
Figure 6.	CX06833 Hardware Signals for Serial Interface (PARIF = Low)	43
Figure 7.	CX06833 144-Pin TQFP Pin Signals for Serial Interface (PARIF = Low)	44
Figure 8.	CX20452 VC Hardware Interface Signals	59
Figure 9.	CX20452 VC 24-Pin QFN Pin Signals	60
Figure 10.	Waveforms - External Memory Bus	68
Figure 11.	Waveforms - Parallel Host Bus	70
Figure 12.	Waveforms - Serial DTE Interface	71
Figure 13.	Package Dimensions - 144-Pin TQFP	73
Figure 14.	Package Dimensions - 24-Pin QFN	74

Tables

Table 1.	SMXXD Modem Models and Functions	12
Table 2.	Default Countries Supported	19
Table 3.	+MS Command Automode Connectivity	25
Table 4.	CX06833 144-Pin TQFP Pin Signals for Parallel Interface (PARIF = High)	40
Table 5.	CX06833 144-Pin TQFP Pin Signals for Serial Interface (PARIF = Low)	45
Table 6.	CX06833 Pin Signal Definitions	48
Table 7.	CX06833 I/O Type Definitions	56
Table 8.	CX06833 DC Electrical Characteristics	57
Table 9.	CX20452 VC 24-Pin QFN Pin Signals	61
Table 10.	CX20452 VC Pin Signal Definitions	62
Table 11.	CX20452 VC DC Electrical Characteristics	63
Table 12.	CX20452 VC Analog Electrical Characteristics	64
Table 13.	Operating Conditions	65
Table 14.	Absolute Maximum Ratings	65
Table 15.	Current and Power Requirements	66
Table 16.	Timing - External Memory Bus	67
Table 17.	Timing - Parallel Host Bus	69
Table 18.	Crystal Specifications	72
Table 19.	Parallel Interface Registers	75
Table 20.	Interrupt Sources and Reset Control	80
Table 21.	Programmable Baud Rates	85

Introduction

1.1 Overview

The Conexant SMXXD Modem is a full-featured, controller-based modem that integrates modem controller (MCU), modem data pump (MDP), 256 KB ROM, 32 KB RAM, and analog line interface codec functions into a single package.

The modem operates by executing firmware from internal ROM and RAM. Optional customized firmware is supported with optional external flash ROM memory. Additionally, added/modified country profiles are supported by internal SRAM patch (maximum of one profile) or serial EEPROM. Downloadable architecture supports downloading of customized MCU firmware from the host/DTE to the SMXXD modem.

The SMXXD Modem device set, consisting of a CX06833 modem device in a 144-pin TQFP and an optional CX20452 Voice Codec (VC) in a 24-pin QFN.

Low profile TQFP and QFN packages with reduced voltage operation and low power consumption make this modem an ideal solution for embedded applications using parallel host or serial DTE interface.

The SMXXD Modem supports data rates up to V.92, data compression, error correction, fax rates up to 14.4 kbps and speakerphone mode.

In V.92 and V.90 (V.92 models) data modes, the modem can receive data at speeds up to 56 kbps. In V.34 data mode (V.92 and V.34 models), the modem can receive data at speeds up to 33.6 kbps. In V.32 bis data mode, the modem can receive data at speeds up to 14.4 kbps.

Data compression (V.44/V.42bis/MNP5) and error correction (V.42/MNP 2 4) modes are supported to maximize data throughput and data transfer integrity. Non-error-correction mode is also supported.

Fax Group 3 send and receive rates are supported up to 14.4 kbps with T.30 protocol.

The SMXXD modem operates with PSTN telephone lines worldwide.

S models, using the optional CX20452 Voice Codec (VC) in a 24-pin QFN, support position independent, full-duplex speakerphone (FDSP) operation using microphone and speaker, as well as other voice/TAM applications using handset or headset.

[Table 1](#) lists the available models. A simplified device interface drawing is shown in [Figure 1](#). A functional interface drawing showing optional memory is shown in [Figure 2](#).

1.2 Applications

- ◆ Internet appliances
- ◆ Remote monitoring and data collection systems
- ◆ Serial box modems
- ◆ Standalone TAM/fax machines
- ◆ Set top boxes
- ◆ Security devices

Table 1. SMXXD Modem Models and Functions

Marketing Name/Order Number/Part Number				Supported Functions			
Marketing Name	Device Set Order Number	Single Chip Modem [144-Pin TQFP] Part Number	Voice Codec (VC) [24-Pin QFN] Part Number	V.90 Data, QC, MOH, PCM	V.34 Data	V.32 bis Data, V.44 Data Compression, V.17 Fax, TAM, Worldwide	Voice/FDSP
Embedded Applications							
SM56D/LF	DS56-L147-043	CX06833-44	—	Y	Y	Y	—
SM336D/LF	DS28-L147-043	CX06833-42	—	—	Y	Y	—
SM144D/LF	DS96-L147-043	CX06833-43	—	—	—	Y	—
SM56D/LF-S	DS56-L147-045	CX06833-44	CX20452-A	Y	Y	Y	Y
SM336D/LF-S	DS28-L147-045	CX06833-42	CX20452-A	—	Y	Y	Y
SM144D/LF-S	DS96-L147-045	CX06833-43	CX20452-A	—	—	Y	Y
Aftermarket Applications							
SM56D/SP-LF	DS56-L144-372	CX06833-44	CX20452-A	Y	Y	Y	Y
GENERAL NOTES:							
1. Model options: S or SPVoice/full-duplex speakerphone (FDSP) 5656 kbps max. rate per V.90 33633.6 kbps max. rate per V.34 14414.4 kbps max. rate per V.32 bis							
2. Supported functions (Y = Supported; — = Not supported): QC = Quick connect MOH = Modem-on-Hold PCM = PCM upstream TAM = Telephone answering machine (Voice playback and record through telephone line) FDSP = Full-duplex speakerphone and voice playback and record through telephone line, handset, and mic/speaker							
3. All devices are lead (Pb)-free and RoHS-compliant. These devices are compatible with leaded reflow processes.							

Figure 1. SMXXD Modem Simplified Interface Diagram

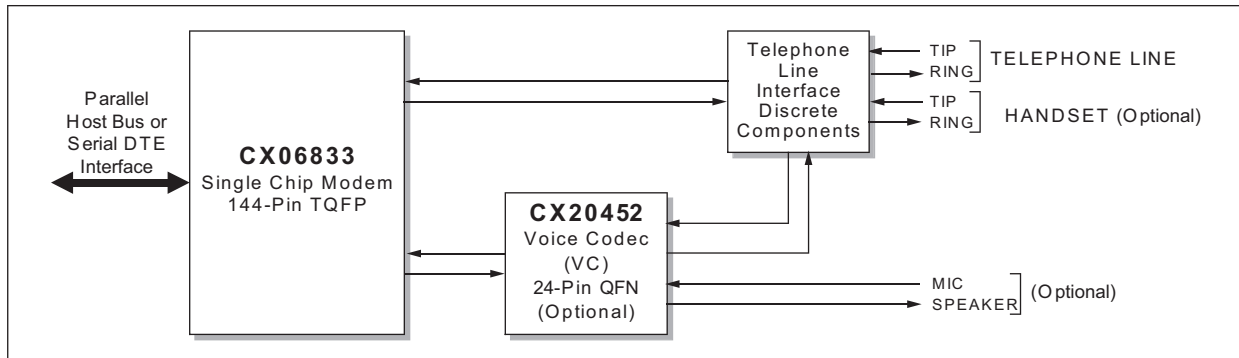
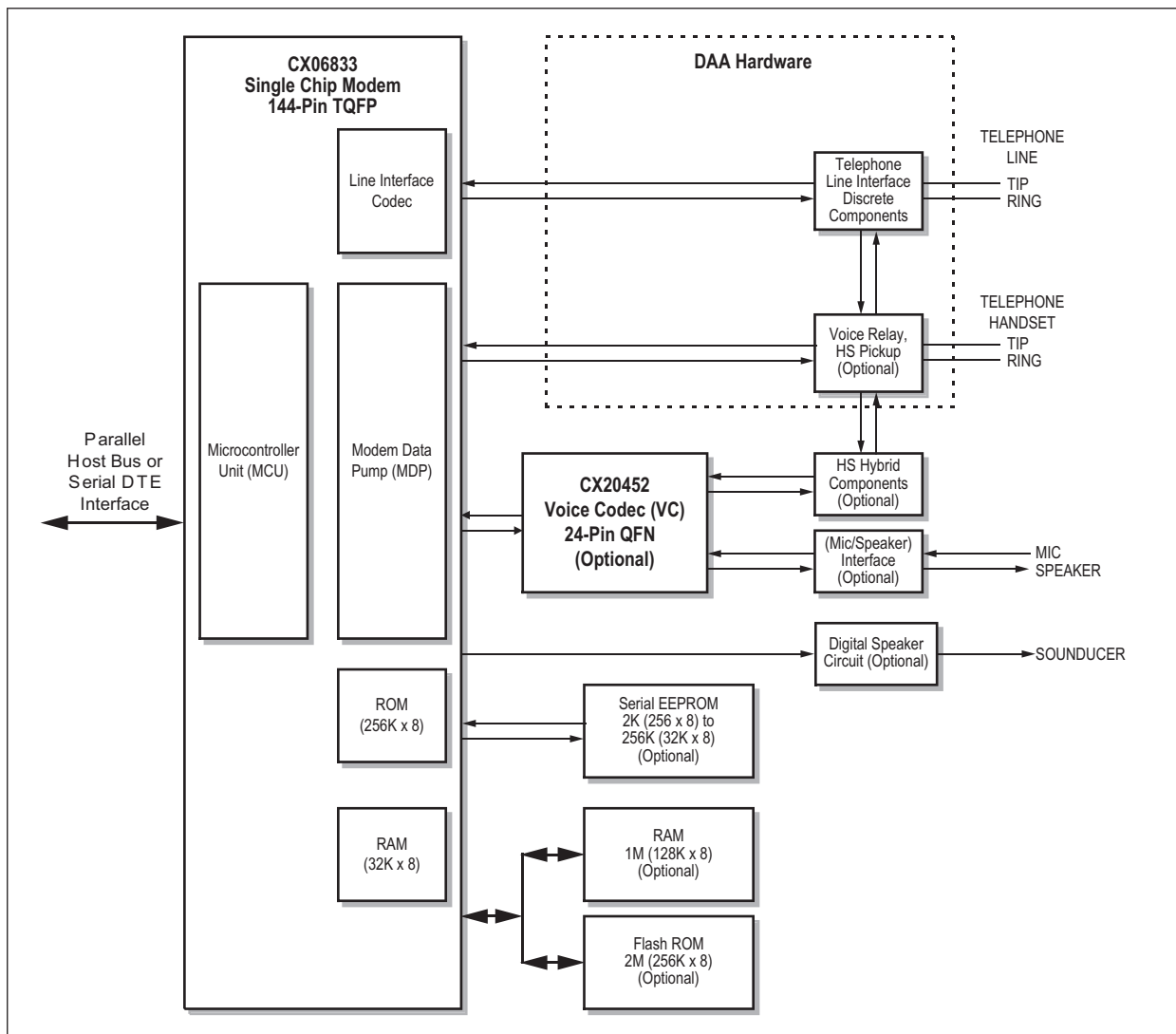

Figure 2. SMXXD Modem Major Interfaces



1.3 Features

1.3.1 General Modem Features

- ◆ Data modem
 - Quick connect, Modem-on-Hold, and PCM upstream functions (V.92 models)
 - ITU-T V.92/V.90 (V.92 models), V.34 (V.92 and V.34 models), V.32bis, V.32, V.29, FastPOS (V.29), V.22 bis, V.22, V.22 Fast Connect, V.23, V.21, Bell 212A, and Bell 103
 - V.250 and V.251 commands
- ◆ Data compression and error correction
 - V.44 data compression
 - V.42 bis and MNP 5 data compression
 - V.42 LAPM and MNP 2-4 error correction
 - Fax modem send and receive rates up to 14.4 kbps
 - V.17, V.29, V.27 ter, and V.21 channel 2
 - EIA/TIA 578 Class 1 and T.31 Class 1.0
- ◆ V.80 synchronous access mode supports host-controlled communication protocols with H.324 interface support
- ◆ Interfaces to optional external ROM/flash ROM, RAM, and/or optional serial EEPROM
- ◆ Data/Fax/Voice call discrimination
- ◆ Hardware-based modem controller
- ◆ Hardware-based digital signal processor (DSP)
- ◆ Support for many country-specific DAA configurations
 - On-hook and/or off-hook Caller ID detection for selected countries
 - Call progress, blacklisting
 - Internal ROM includes default values for 29 countries
 - Additional and modified country profile can be stored in internal SRAM
- ◆ Caller waiting detection
- ◆ Caller ID detect
 - On-hook Caller ID detection
 - Off-hook Call Waiting Caller ID detection during data mode in V.92, V.90, V.34, V.32bis, and V.32
- ◆ Distinctive ring detect
- ◆ Modem customization available through patch code that can be stored in optional serial EEPROM or internal SRAM
- ◆ Telephony/TAM
 - V.253 commands

- 2-bit and 4-bit Conexant ADPCM, 8-bit linear PCM, and 4-bit IMA coding
- 8 kHz sample rate
- Concurrent DTMF, ring, and Caller ID detection
- ◆ Full-duplex speakerphone (FDSP) mode using optional CX20452 Voice Codec (S models)
 - Microphone and speaker interface
 - Telephone handset or headset interface
 - Acoustic and line echo cancellation
 - Microphone gain and muting
 - Speaker volume control and muting
- ◆ Built-in host/DTE interface
 - Parallel 16550A UART-compatible interface up to 230.4 kbps
 - Serial ITU-T V.24 (EIA/TIA-232-E) logical interface up to 115.2 kbps
- ◆ Downloadable architecture
- ◆ Direct mode (serial DTE interface)
- ◆ Flow control and speed buffering
- ◆ Automatic format/speed sensing
- ◆ Serial async/sync data; parallel async data
- ◆ Thin packages support low profile designs (1.6 mm max. height)
 - CX06833 Modem device in 144-pin TQFP
 - CX20452 VC in 24-pin QFN
- ◆ +3.3V operation with +5V tolerant digital inputs
- ◆ Typical power use
 - CX06833: 191 mW (Normal Mode); 53 mW (Sleep Mode)
 - CX20452: 5 mW (Normal Mode)

1.4 Technical Overview

1.4.1 General Description

Modem operation, including dialing, call progress, telephone line interface, telephone handset interface, optional voice/speakerphone interface, and host interface functions are supported and controlled through the V.250, V.251, and V.253-compatible command set.

The modem hardware connects to the host via a parallel or serial interface as selected by the PARIF input. The OEM adds a crystal circuit, telephone line interface, telephone handset/telephony extension interface, voice/speakerphone interface, optional external serial EEPROM, optional external ROM/flash ROM, optional external RAM, and other supporting discrete components as supported by the modem model (Table 1) and required by the application to complete the system.

Customized modem firmware can be supported by the use of external memory in various combinations, e.g., either external ROM/flash ROM (up to 256 KB), or external serial EEPROM (256 to 32 KB) and external RAM (up to 128 KB). To support country profile addition or modification, external serial EEPROM (256 to 32 KB) can be installed. Customized code can include OEM-defined commands, i.e., identification codes (I3), identifier string (I4), manufacturer identification (+GMI), model identification (+GMM), and revision identification (+GMR), as well as code modification.

Parallel interface operation is selected by PARIF input high.

Serial interface operation is selected by PARIF input low.

1.4.2 MCU Firmware

MCU firmware performs processing of general modem control, command sets, data modem, error correction and data compression (ECC), fax class 1, fax class 1.0, voice/audio/TAM/speakerphone, worldwide, V.80, and serial DTE/parallel host interface functions according to modem models (Table 1).

MCU firmware can be customized to include OEM-defined commands, i.e., identification codes (I3), identifier string (I4), manufacturer identification (+GMI), model identification (+GMM), and revision identification (+GMR), as well as code modification.

The modem firmware is provided in object code form for the OEM to program into external ROM/flash ROM. The modem firmware may also be provided in source code form under a source code addendum license agreement. External ROM/Flash ROM and RAM must be installed in order to operate the modem with customized firmware.

1.4.3 Operating Modes

1.4.3.1 Data/Fax Modes

Data modem modes perform complete handshake and data rate negotiations. Using modem modulations to optimize modem configuration for line conditions, the modem can connect at the highest data rate that the channel can support from 56 kbps down to 2400 bps with automatic fallback.

In V.92/V.90 data modem modes (V.92 models), the modem can receive data from a digital source using a V.92-compatible central site modem at line speeds up to 56 kbps. With PCM upstream enabled (V.92 only), data transmission supports sending data at line speeds up to 48 kbps. When PCM upstream is disabled, data transmission supports sending data at line speeds up to V.34 rates. This mode can fallback to V.34 mode and to lower rates as dictated by line conditions.

The following modes are supported in V.92 models when connected to a V.92-compatible server supporting the feature listed.

- ◆ Quick connect: Allows quicker subsequent connections to a server by using stored line parameters obtained during the initial connection.
- ◆ Modem-on-Hold: Allows detection and reporting of incoming phone calls on the PSTN with enabled Call Waiting. If the incoming call is accepted by the user, the user has a pre-defined amount of time of holding the data connection for a brief conversation. The data connection resumes upon incoming call termination.
- ◆ PCM upstream: Boosts the upstream data rates. A maximum of 48 kbps is supported when connected to a V.92 server that supports PCM upstream.

In V.34 data modem mode (V.92 and V.34 models), the modem can operate in full-duplex, asynchronous modes at line rates up to 33.6 kbps. Automode operation in V.34 is provided in accordance with PN3320 and in V.32 bis in accordance with PN2330. All tone and pattern detection functions required by the applicable ITU or Bell standards are supported.

In V.32 bis data modem mode, the modem can operate at line speeds up to 14.4 kbps.

In fax modem mode, the modem can operate in half-duplex, synchronous modes and can support Group 3 facsimile send and receive speeds of 14400, 12000, 9600, 7200, 4800, and 2400 bps. Fax data transmission and reception performed by the modem are controlled and monitored through the EIA/TIA-578 Fax Class 1, or T.31 Fax Class 1.0 command interface. Full HDLC formatting, zero insertion/deletion, and CRC generation/checking are provided.

1.4.3.2 V.44 Data Compression

V.44 provides efficient data compression that minimizes the download time for the types of files associated with Internet use. This improvement is most noticeable when browsing and searching the web since HTML text files are highly compressible. (The improved performance amount varies both with the actual format and with the content of individual pages and files.)

1.4.3.3 Country Support

Country-specific modem parameters for functions such as dialing, carrier transmit level, calling tone, call progress tone detection, answer tone detection, blacklisting, caller ID, and relay control are programmable.

Country code IDs are defined by ITU-T T.35.

Embedded ROM code includes default profiles for 29 countries. Additional country profiles can be stored in internal SRAM or external serial EEPROM (request additional country profiles from a Conexant Sales Office). Duplicate country profiles stored in internal SRAM or external serial EEPROM will override the profiles in embedded ROM code. The default countries supported are listed [Table 2](#). Country profiles for CTR 21 countries are TBR-21 compliant.

1.4.3.4 TAM Mode

TAM Mode features include 8-bit linear coding at 8 kHz sample rate. Tone detection/generation, call discrimination, and concurrent DTMF detection are also supported.

TAM Mode is supported by four submodes:

- ◆ Online Voice Command Mode supports connection to the telephone line or, for S models, a microphone/speaker/handset/headset.
- ◆ Voice Receive Mode supports recording voice or audio data input from the telephone line or, for S models, a microphone/handset/headset.
- ◆ Voice Transmit Mode supports playback of voice or audio data to the telephone line or, for S models, a speaker/handset/headset.
- ◆ Full-duplex Receive and Transmit Mode.

Table 2. Default Countries Supported

Country	Country Code	Call Waiting Tone Detection (CW) Supported	On-Hook Type 1 Caller ID (CID) Supported	Off-Hook Type 2 Called ID (CID2) Supported
Australia	09	X	X	
Austria	0A	X	X	
Belgium	0F	X		
Brazil	16	X		
China	26	X	X	
Denmark	31	X	X	
Finland	3C	X	X	
France	3D	X	X	X
Germany	42	X	X	
Hong Kong	50	X	X	X
India	53		X	
Ireland	57		X	
Italy	59	X	X	
Japan	00	X	X	X
Korea	61	X		
Malaysia	6C	X		
Mexico	73			
Netherlands	7B		X	
Norway	82	X	X	
Poland	8A	X		
Portugal	8B	X		
Singapore	9C	X	X	X
South Africa	9F	X		
Spain	A0	X	X	
Sweden	A5	X	X	
Switzerland	A6	X		
Taiwan	FE	X	X	
United Kingdom	B4	X	X	X
United States	B5	X	X	X
Reserved	FD	X	X	X

1.4.3.5 Speakerphone Mode (S Models)

S models include additional telephone handset, external microphone, and external speaker interfaces which support voice and full-duplex speakerphone (FDSP) operation.

Hands-free full-duplex telephone operation is supported in Speakerphone Mode under host control. Speakerphone Mode features an advanced proprietary speakerphone algorithm which supports full-duplex voice conversation with acoustic, line, and handset echo cancellation. Parameters are constantly adjusted to maintain stability with automatic fallback from full-duplex to pseudo-duplex operation. The speakerphone algorithm allows position independent placement of microphone and speaker. The host can separately control volume, muting, and AGC in microphone and speaker channels.

1.4.4 Reference Designs

Data/fax/TAM/speakerphone reference designs for external modems are available to minimize application design time, reduce development cost, and accelerate market entry. For CX06833, these designs are RD01-D460-1xx.

A design package is available in electronic form. This package includes schematics, bill of materials (BOM), vendor part list (VPL), board layout files in Gerber format, and complete documentation.

1.5 Hardware Description

1.5.1 CX06833 Modem Device

The CX06833 Modem, packaged in a 144-pin TQFP, includes a Microcontroller (MCU), a Modem Data Pump (MDP), 256 KB internal ROM, and 32 KB internal RAM interface functions.

The CX06833 Modem connects to host via a parallel host (PARIF = high) or a logical V.24 (EIA/TIA-232-E) serial DTE interface (PARIF = low).

The CX06833 Modem performs the command processing and host interface functions. The crystal frequency is 28.224 MHz \pm 50 ppm.

The CX06833 Modem optionally connects to an external OEM-supplied serial EEPROM over a dedicated 2-line serial interface. The capacity of the EEPROM can be 256 bytes up to 32 KB. The EEPROM can hold information such as firmware configuration customization, and country code parameters.

The CX06833 Modem performs telephone line signal modulation/demodulation in a hardware digital signal processor (DSP) which reduces computational load on the host processor.

The CX06833 optionally connects to external OEM-supplied ROM/flash ROM and RAM over a non-multiplexed 19-bit address bus and 8-bit data bus.

1.5.2 CX20452 Voice Codec

The optional CX20452 Voice Codec (VC), packaged in a 24-pin QFN, supports voice/full-duplex speakerphone (FDSP) operation with interfaces to a microphone and speaker and to a telephone handset/headset.

1.6 AT Commands

The SMXXD Modem supports AT commands for data mode, fax class 1 or 1.0, voice/audio, full-duplex speakerphone (FDSP), V.80 commands, and S Register. See Doc. No. 102184 for a description of the commands.

Data Mode Operation. Data functions operate in response to the AT commands when +FCLASS=0. Default parameters support U.S./Canada operation.

Fax Mode Operation. Facsimile functions operate in response to fax class 1 commands when +FCLASS=1 or to fax class 1.0 commands when +FCLASS=1.0.

Voice/Audio Operation. Voice/audio functions operate in response to voice/audio commands when +FCLASS=8.

Speakerphone Operation. FDSP functions operate in response to speakerphone commands when +FCLASS=8 and +VSP=1 is selected.

Technical Specifications

2.1 Serial DTE Interface Operation

2.1.1 Automatic Speed/Format Sensing

2.1.1.1 Command Mode and Data Mode

The modem can automatically determine the speed and format of the data sent from the DTE. The modem can sense speeds of 300, 600, 1200, 2400, 4800, 7200, 9600, 12000, 14400, 16800, 19200, 21600, 24000, 26400, 28800, 38400, 57600, and 115200 bps and the following data formats:

Parity	Data Length (Number of Bits)	Number of Stop Bits	Character Length (Number of Bits)
None	7	2	10
Odd	7	1	10
Even	7	1	10
None	8	1	10
Odd	8	1	11 ⁽¹⁾
Even	8	1	11 ⁽¹⁾

FOOTNOTES:
⁽¹⁾ 11-bit characters are sensed, but the parity bit is stripped off during data transmission in Normal and Error Correction modes.

The modem can speed sense data with mark or space parity and configures itself as follows:

DTE Configuration	Modem Configuration
7 mark	7 none
7 space	8 none
8 mark	8 none
8 space	8 even

2.1.1.2 Fax Mode

In V.17 fax mode, the modem can sense speeds up to 115.2 kbps.

2.2 Parallel Host Bus Interface Operation

Command Mode and Data Mode. The modem can operate at rates up to 230.4 kbps by programming the Divisor Latch in the parallel interface registers if supported by communications software and/or driver.

Fax Mode. In V.17 mode, the modem can operate at rates up to 230.4 kbps by programming the Divisor Latch in the parallel interface registers if supported by communications software and/or driver.

2.3 Establishing Data Modem Connections

2.3.1 Dialing

DTMF Dialing. DTMF dialing using DTMF tone pairs is supported in accordance with ITU-T Q.23. The transmit tone level complies with Bell Publication 47001.

Pulse Dialing Pulse dialing is supported in accordance with EIA/TIA-496-A.

Blind Dialing The modem can blind dial in the absence of a dial tone if enabled by the X0, X1, or X3 command.

2.3.2 Telephone Number Directory

The modem supports four telephone number entries in a directory that can be saved in a serial EEPROM. Each telephone number can be up to 32 characters (including the command line terminating carriage return) in length. A telephone number can be saved using the &Zn=x command, and a saved telephone number can be dialed using the DS=n command.

2.3.3 Modem Handshaking Protocol

If a tone is not detected within the time specified in the S7 register after the last digit is dialed, the modem aborts the call attempt.

2.3.4 Call Progress Tone Detection

Ringback, equipment busy, congested tone, warble tone, and progress tones can be detected in accordance with the applicable standard.

2.3.5 Answer Tone Detection

Answer tone can be detected over the frequency range of 2100 ± 40 Hz in ITU-T modes and 2225 ± 40 Hz in Bell modes.

2.3.6 Ring Detection

A ring signal can be detected from a TTL-compatible 15.3 Hz to 68 Hz square wave input.

2.3.7 Billing Protection

When the modem goes off-hook to answer an incoming call, both transmission and reception of data are prevented for 2 seconds (data modem) or 4 seconds (fax adaptive answer) to allow transmission of the billing tone signal.

2.3.8 Connection Speeds

The modem functions as a data modem when the +FCLASS=0 command is active.

Line connection can be selected using the +MS command. The +MS command selects modulation, enables/disables automode, and selects minimum and maximum line speeds ([Table 3](#)).

2.3.9 Automode

Automode detection can be enabled by the +MS command to allow the modem to connect to a remote modem in accordance with draft PN-3320 for V.34 ([Table 3](#)).

Table 3. +MS Command Automode Connectivity

Modulation	<carrier>	Possible (<min_rx_rate>, <min_rx_rate>, (<min_tx_rate>), and <max_tx_rate>) Rates (bps)
Bell 103	B103	300
Bell 212	B212	1200 Rx/75 Tx or 75 Rx/1200 Tx
V.21	V21	300
V.22	V22	1200
V.22 bis	V22B	2400 or 1200
V.23	V23C	1200
V.32	V32	9600 or 4800
V.32 bis	V32B	14400, 12000, 9600, 7200, or 4800
V.34	V34	33600, 31200, 28800, 26400, 24000, 21600, 19200, 16800, 14400, 12000, 9600, 7200, 4800, or 2400
V.90	V90	56000, 54667, 53333, 52000, 50667, 49333, 48000, 46667, 45333, 44000, 42667, 41333, 40000, 38667, 37333, 36000, 34667, 33333, 32000, 30667, 29333, 28000
V.92 downstream	V92	56000, 54667, 53333, 52000, 50667, 49333, 48000, 46667, 45333, 44000, 42667, 41333, 40000, 38667, 37333, 36000, 34667, 33333, 32000, 30667, 29333, 28000
V.92 upstream	V92	48000, 46667, 45333, 44000, 42667, 41333, 40000, 38667, 37333, 36000, 34667, 33333, 32000, 30667, 29333, 28000, 26667, 25333, 24000

2.4 Data Mode

The modem enters data mode when a telephone line connection has been established between modems and all handshaking has been completed.

2.4.1 Speed Buffering (Normal Mode)

Speed buffering allows a DTE to send data to, and receive data from, a modem at a speed different than the line speed. The modem supports speed buffering at all line speeds.

2.4.2 Flow Control

DTE-to-Modem Flow Control. If the modem-to-line speed is less than the DTE-to-modem speed, the modem supports XOFF/XON or RTS/CTS flow control with the DTE to ensure data integrity.

2.4.3 Escape Sequence Detection

The +++ escape sequence can be used to return control to the command mode from the data mode. Escape sequence detection is disabled by an S2 Register value greater than 127.

2.4.4 BREAK Detection

The modem can detect a BREAK signal from either the DTE or the remote modem. The \Kn command determines the modem response to a received BREAK signal.

2.4.5 Telephone Line Monitoring

GSTN Cleardown (V.90, V.34, V.32 bis, V.32). Upon receiving GSTN Cleardown from the remote modem in a non-error correcting mode, the modem cleanly terminates the call.

Loss of Carrier (V.22 bis and Below). If carrier is lost for a time greater than specified by the S10 register, the modem disconnects.

2.4.6 Fall Forward/Fallback (V.92/V.90/V.34/V.32 bis/V.32)

During initial handshake, the modem will fallback to the optimal line connection within V.92/V.90/V.34/V.32 bis/V.32 mode depending upon signal quality if automode is enabled by the +MS or N1 command.

When connected in V.92/V.90/V.34/V.32 bis/V.32 mode, the modem will fall forward or fallback to the optimal line speed within the current modulation depending upon signal quality if fall forward/fallback is enabled by the %E2 command.

2.4.7 Retrain

The modem may lose synchronization with the received line signal under poor or changing line conditions. If this occurs, retraining may be initiated to attempt recovery depending on the type of connection.

The modem initiates a retrain if line quality becomes unacceptable if enabled by the %E command. The modem continues to retrain until an acceptable connection is achieved, or until 30 seconds elapse resulting in line disconnect.

2.4.8 Programmable Inactivity Timer

The modem disconnects from the line if data is not sent or received for a specified length of time. In normal or error-correction mode, this inactivity timer is reset when data is received from either the DTE or from the line. This timer can be set to a value between 0 and 255 seconds by using register S30. A value of 0 disables the inactivity timer.

2.4.9 DTE Signal Monitoring (Serial DTE Interface Only)

DTR#. When DTR# is asserted, the modem responds in accordance with the &Dn and &Qn commands.

RTS#. RTS# is used for flow control if enabled by the &K command in normal or error-correction mode.

2.5 V.92 Features

Modem-on-Hold, quick connect, and PCM upstream are only available in V.92 models when connecting in V.92 data mode. V.92 features are only available when the server called is a V.92 server that supports that particular feature.

2.5.1 Modem-on-Hold

- ◆ The Modem-on-Hold (MOH) function enables the modem to place a data call to the Internet on hold while using the same line to accept an incoming or place an outgoing voice call. This feature is available only with a connection to a server supporting MOH. MOH can be executed through either of two methods:
- ◆ One method is to enable MOH through the +PMH command. With Call Waiting Detection (+PCW command) enabled, an incoming call can be detected while on-line. Using a string of commands, the modem negotiates with the server to place the data connection on hold while the line is released so that it can be used to conduct a voice call. Once the voice call is completed, the modem can quickly renegotiate with the server back to the original data call.
- ◆ An alternative method is to use communications software that utilizes the Conexant Modem-on-Hold drivers under Windows PC operating systems. Using this method, the software can detect an incoming call, place the data connection on hold, and switch back to a data connection.

2.5.2 Quick Connect

The quick connect function enables the modem to shorten the connect time of subsequent calls to a server supporting quick connect. The quick connect feature is supported by the +PQC command.

2.5.3 PCM Upstream

PCM upstream boosts the upstream data rates between the user and ISP to reduce upload times for large files and email attachments. A maximum of 48 kbps upstream rate is supported with PCM upstream enabled, in contrast to a maximum of 32.2 kbps upstream rate with PCM upstream not enabled. PCM upstream is supported by the +PCM command. PCM upstream is disabled by default.

2.6 Error Correction and Data Compression

2.6.1 V.42 Error Correction

V.42 supports two methods of error correction: LAPM and, as a fallback, MNP 4. The modem provides a detection and negotiation technique for determining and establishing the best method of error correction between two modems.

2.6.2 MNP 2-4 Error Correction

MNP 2-4 is a data link protocol that uses error correction algorithms to ensure data integrity. Supporting stream mode, the modem sends data frames in varying lengths depending on the amount of time between characters coming from the DTE.

2.6.3 V.44 Data Compression

V.44 data compression mode, enabled by the +DS44 command, encodes pages and files associated with Web pages. These files include WEB pages, graphics and image files, and document files. V.44 can provide an effective data throughput rate up to DTE rate for a 56-kbps connection. The improved performance amount varies both with the actual format and with the content of individual pages and files.

2.6.4 V.42 bis Data Compression

V.42 bis data compression mode, enabled by the %Cn command or S46 register, operates when a LAPM connection is established.

The V.42 bis data compression employs a string learning algorithm in which a string of characters from the DTE is encoded as a fixed length codeword. Two 2-KB dictionaries are used to store the strings. These dictionaries are dynamically updated during normal operation.

2.6.5 MNP 5 Data Compression

MNP 5 data compression mode, enabled by the %Cn command, operates during an MNP connection.

In MNP 5, the modem increases its throughput by compressing data into tokens before transmitting it to the remote modem, and by decompressing encoded received data before sending it to the DTE.

2.7 Telephony Extensions

The following telephony extension features are supported and are typically implemented in designs for set-top box applications and TAM software applications to enhance end-user experience:

- ◆ Line In Use detection
- ◆ Extension Pickup detection
- ◆ Remote Hang-up detection

The telephony extension features are enabled through the -STE command. The -TTE command can be used to adjust the voltage thresholds for the telephony extension features.

2.7.1 Line In Use Detection

The Line In Use Detection feature can stop the modem from disturbing the phone line when the line is already being used. When an automated system tries to dial using ATDT and the phone line is in use, the modem will not go off hook and will respond with the message LINE IN USE. In the case where no phone line is connected to the modem, the modem will respond with the message NO LINE.

2.7.2 Extension Pickup Detection

The Extension Pickup Detection feature (also commonly referred as PPD or Parallel phone detection) allows the modem to detect when another telephony device (i.e., fax machine, phone, satellite/cable box) is attempting to use the phone line. When an extension pickup has been detected, the modem will go on-hook and respond with the message OFF-HOOK INTRUSION.

The Remote Hang-up Detection feature will cause the modem to go back on-hook and respond with the message LINE REVERSAL DETECTED during a data connection when the remote modem is disconnected for abnormal termination reasons (remote phone line unplugged, remote server/modem shutdown). For Voice applications, this method can be used in addition to silence detection to determine when a remote caller has hung up to terminate a voice recording.

This feature can be used to quickly drop a modem connection in the event when a user picks up a extension phone line. For example, this feature allows set top boxes with an integrated SMXXD modem to give normal voice users the highest priority over the telephone line.

This feature can also be used in Telephone Answering Machine applications (TAM). Its main use would be to stop the TAM operation when a phone is picked up.

2.7.3 Remote Hang-up Detection

The Remote Hang-up Detection feature will cause the modem to go back on-hook and respond with the message LINE REVERSAL DETECTED during a data connection when the remote modem is disconnected for abnormal termination reasons (remote phone line unplugged, remote server/modem shutdown). For Voice applications, this method can be used in addition to silence detection to determine when a remote caller has hung up to terminate a voice recording.

2.8 Fax Class 1 and Fax Class 1.0 Operation

Facsimile functions operate in response to fax class 1 commands when +FCLASS=1 or to fax class 1.0 commands when +FCLASS=1.0.

In the fax mode, the on-line behavior of the modem is different from the data (non-fax) mode. After dialing, modem operation is controlled by fax commands. Some AT commands are still valid but may operate differently than in data modem mode.

Calling tone is generated in accordance with T.30.

2.9 Point-of-Sales Support

Point-of-Sales (POS) terminals usually need to exchange a small amount of data in the shortest amount of time. Low speed modulations such as Bell212A or V.22 are still mainly used in POS applications. Additionally, new non-standard sequences have been developed to better support POS applications.

Industry standard and shortened answer tone B103 and V.21 are supported, as well as FastPOS (V.29) and V.22 Fast Connect. POS terminal modulations are supported by the \$F command.

2.10 Voice/Audio Mode

Voice and audio functions are supported by the Voice Mode. Voice Mode includes four submodes: Online Voice Command Mode, Voice Receive Mode, Voice Transmit Mode and Full-Duplex Receive and Transmit Mode.

2.10.1 Online Voice Command Mode

This mode results from the connection to the telephone line or a voice/audio I/O device (e.g., microphone, speaker, or handset) through the use of the +FCLASS=8 and +VLS commands. After mode entry, AT commands can be entered without aborting the connection.

2.10.2 Voice Receive Mode

This mode is entered when the +VRX command is active in order to record voice or audio data input at the RIN pin, typically from a microphone/handset or the telephone line.

Received analog voice samples are converted to digital form and compressed for reading by the host. AT commands control the codec bits-per-sample rate.

Received analog mono audio samples are converted to digital form and formatted into 8-bit unsigned linear PCM format for reading by the host. AT commands control the bit length and sampling rate. Concurrent DTMF/tone detection is available at the 8 kHz sample rate.

2.10.3 Voice Transmit Mode

This mode is entered when the +VTX command is active in order to playback voice or audio data to the TXA output, typically to a speaker/handset or to the telephone line.

Digitized voice data is decompressed and converted to analog form at the original compression quantization sample-per-bits rate then output to the TXA output.

Digitized audio data is converted to analog form then output to the TXA output.

2.10.4 Full-Duplex Receive and Transmit Mode

This mode is entered when the +VTR command is active in order to concurrently receive and transmit voice.

2.10.5 Audio Mode

The audio mode enables the host to transmit and receive 8-bit audio signals. In this mode, the modem directly accesses the internal analog-to-digital (A/D) converter (ADC) and the digital-to-analog (D/A) converter (DAC). Incoming analog audio signals can then be converted to digital format and digital signals can be converted to analog audio output.

2.10.6 Tone Detectors

The tone detector signal path is separate from the main received signal path thus enabling tone detection to be independent of the configuration status. In Tone Mode, all three tone detectors are operational.

2.10.7 Speakerphone Mode

Speakerphone mode is controlled in voice mode with the following commands:

Use Speakerphone After Dialing or Answering (+VSP=1). +VSP=1 selects speakerphone mode while in +FCLASS=8 mode. Speakerphone operation is entered during Voice Online Command mode after completing dialing or answering.

Speakerphone Settings. The +VGM and +VGS commands can be used to control the microphone gain and speaker volume, respectively. VGM and +VGS commands are valid only after the modem has entered the Voice Online mode while in the +VSP=1 setting.

2.11 V.80 Synchronous Access Mode (SAM) - Video Conferencing

V.80 Synchronous Access Mode between the modem and the host/DTE is provided for host-controlled communication protocols, e.g., H.324 video conferencing applications.

Voice-call-first (VCF) before switching to a videophone call is also supported.

2.12 Full-Duplex Speakerphone (FDSP) Mode (S Models)

The modem operates in FDSP mode when +FCLASS=8 and +VSP=1 ([Section 2.10.7](#)).

In FDSP Mode, speech from a microphone or handset is converted to digital form, shaped, and output to the telephone line through the line interface circuit. Speech received from the telephone line is shaped, converted to analog form, and output to the speaker or handset. Shaping includes both acoustic and line echo cancellation.

2.13 Caller ID

Both Type I Caller ID (On-Hook Caller ID) and Type II Caller ID (Call Waiting Caller ID) are supported for U.S. and many other countries (see [Section 2.14](#)). Both types of Caller ID are enabled/disabled using the +VCID command. Call Waiting Tone detection must be enabled using the +PCW command to detect and decode Call Waiting Caller ID. When enabled, caller ID information (date, time, caller code, and name) can be passed to the DTE in formatted or unformatted form. Inquiry support allows the current caller ID mode and mode capabilities of the modem to be retrieved from the modem.

Type II Caller ID (Call Waiting Caller ID) detection operates only during data mode in V.92, V.90, V.34, V.32bis, or V.32.

2.14 Worldwide Country Support

Internal modem firmware supports 29 country profiles (see [Section 1.4.3.3](#)). These country profiles include the following country-dependent parameters:

- ◆ Dial tone detection levels and frequency ranges.
- ◆ DTMF dialing parameters: Transmit output level, DTMF signal duration, and DTMF interdigit interval.
- ◆ Pulse dialing parameters: Make/break times, set/clear times, and dial codes are programmable
- ◆ Ring detection frequency range.
- ◆ Type I and Type II Caller ID detection are supported for many countries. Contact your local Conexant sales office for additional country support.
- ◆ Blind dialing enabled/disable.
- ◆ Carrier transmit level (through S91 for data and S92 for fax). The maximum, minimum, and default values can be defined to match specific country and DAA requirements.
- ◆ Calling tone is generated in accordance with V.25. Calling tone may be toggled (enabled/disabled) by inclusion of a ^ character in a dial string. It may also be disabled.
- ◆ Frequency and cadence of tones for busy, ringback, congested, warble, dial tone 1, and dial tone 2.
- ◆ Answer tone detection period.
- ◆ Blacklist parameters. The modem can operate in accordance with requirements of individual countries to prevent misuse of the network by limiting repeated calls to the same number when previous call attempts have failed. Call failure can be detected for reasons such as no dial tone, number busy, no answer, no ringback detected, voice (rather than modem) detected, and key abort (dial attempt aborted by user). Actions resulting from such failures can include specification of minimum inter-call delay, extended delay between calls, and maximum numbers of retries before the number is permanently forbidden (blacklisted).

These country profiles may be altered or customized by modifying the country-dependent parameters. Additional profiles may also be included. There are two ways to add or modify profiles:

- ◆ Incorporating additional or modified profiles into external flash ROM containing the entire modem firmware code.
- ◆ Linking additional or modified profiles from an external serial EEPROM (needed only if the external flash ROM capacity is exceeded).

Please contact an FAE at the local Conexant sales office if a country code customization is required.

2.15 Diagnostics

2.15.1 Commanded Tests

Diagnostics are performed in response to test commands.

Analog Loopback (&T1 Command). Data from the local DTE is sent to the modem, which loops the data back to the local DTE.

DMTF Generation (%TT0 Command). Continuous DTMF tones are generated by the DSP and output through the DAA.

Tone Generation (%TT3 Command). Continuous tones are generated by the DSP and output through the DAA.

2.15.2 Power On Reset Tests

Upon power on, the modem performs tests of the modem and internal RAM. If the modem or internal RAM test fails, the TMIND# output is pulsed as follows (Figure 2 1):

- ◆ Internal RAM test fails: One pulse cycle (pulse cycle = 0.5 sec. on, 0.5 sec. off) every 1.5 seconds.
- ◆ Modem device test fails: Three pulse cycles every 1.5 seconds.

Figure 3. TMIND# Test Results Pulse Cycles

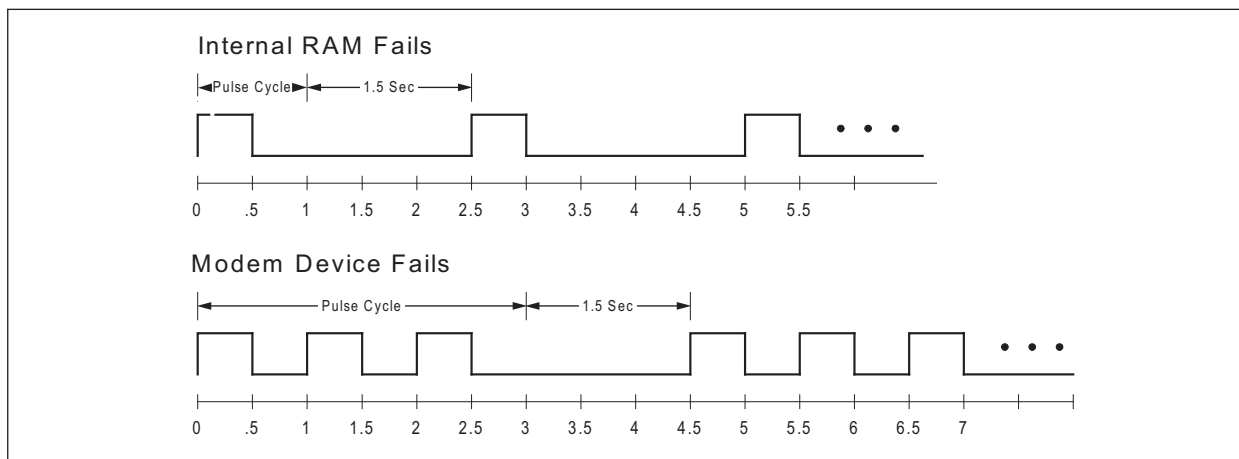

2.16 Low Power Sleep Mode

Sleep Mode Entry	The modem enters the low power sleep mode when no line connection exists and no host activity occurs for the period of time specified in the S24 register. All modem circuits are turned off except the internal clock circuitry in order to consume reduced power while being able to immediately wake up and resume normal operation.
Wake-up	Wake-up occurs when a ring is detected on the telephone line, the host writes to the modem (parallel interface), or the DTE sends a character to the modem (serial interface).

Hardware Interface

3.1 CX06833 Hardware Pins and Signals

3.1.1 CX06833 Interface Signals

CX06833 hardware interface signals for parallel interface are shown by major interface in [Figure 4](#), are shown by pin number in [Figure 5](#), and are listed by pin number in [Table 4](#).

CX06833 hardware interface signals for serial interface are shown by major interface in [Figure 6](#), are shown by pin number in [Figure 7](#), and are listed by pin number in [Table 5](#).

The CX06833 hardware interface signals are defined in [Table 6](#).

CX06833 I/O types are defined in [Table 7](#).

CX06833 DC electrical characteristics are listed in [Table 8](#).

Figure 4. CX06833 Hardware Signals for Parallel Interface (PARIF = High)

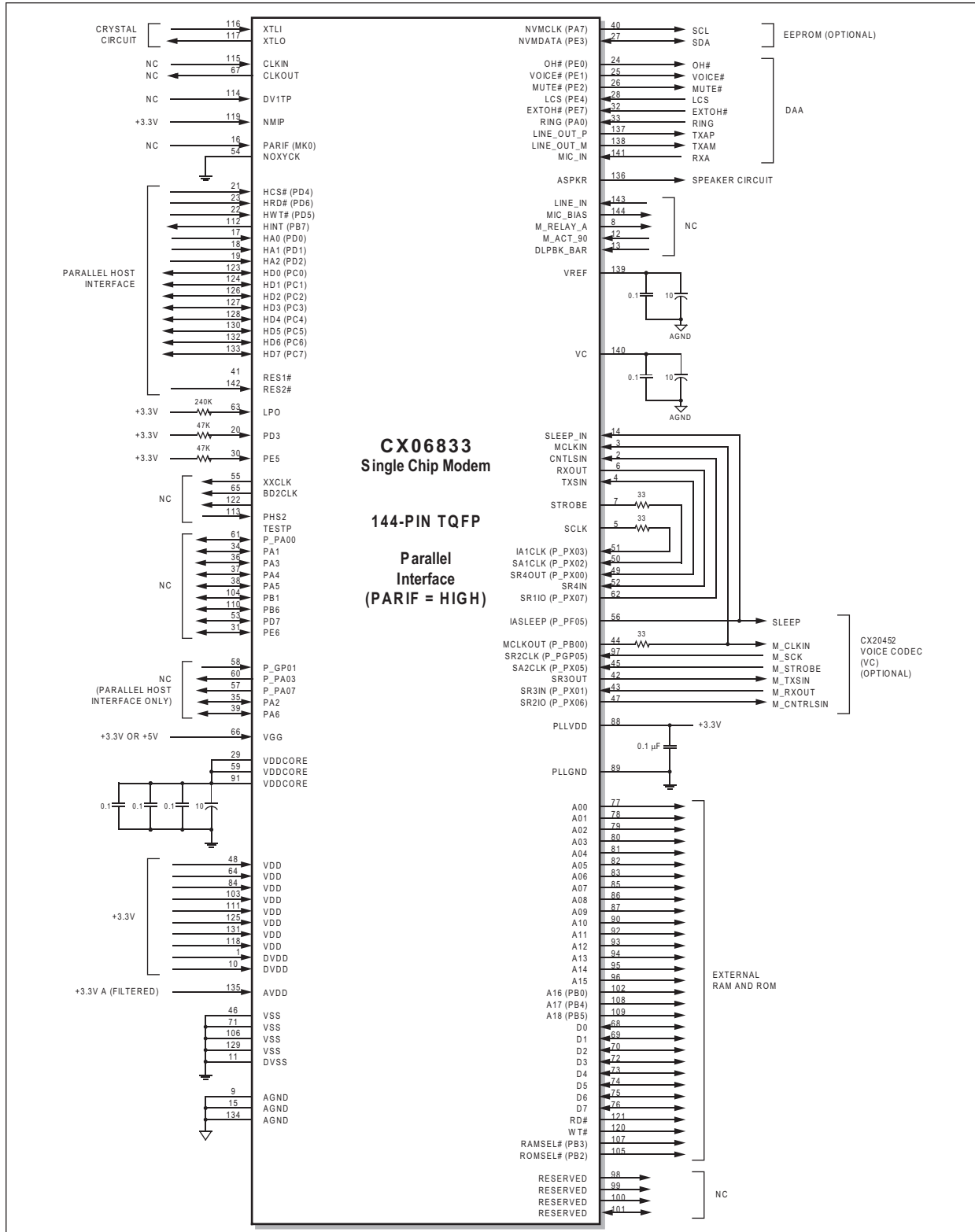

Figure 5. CX06833 144-Pin TQFP Pin Signals for Parallel Interface (PARIF = High)

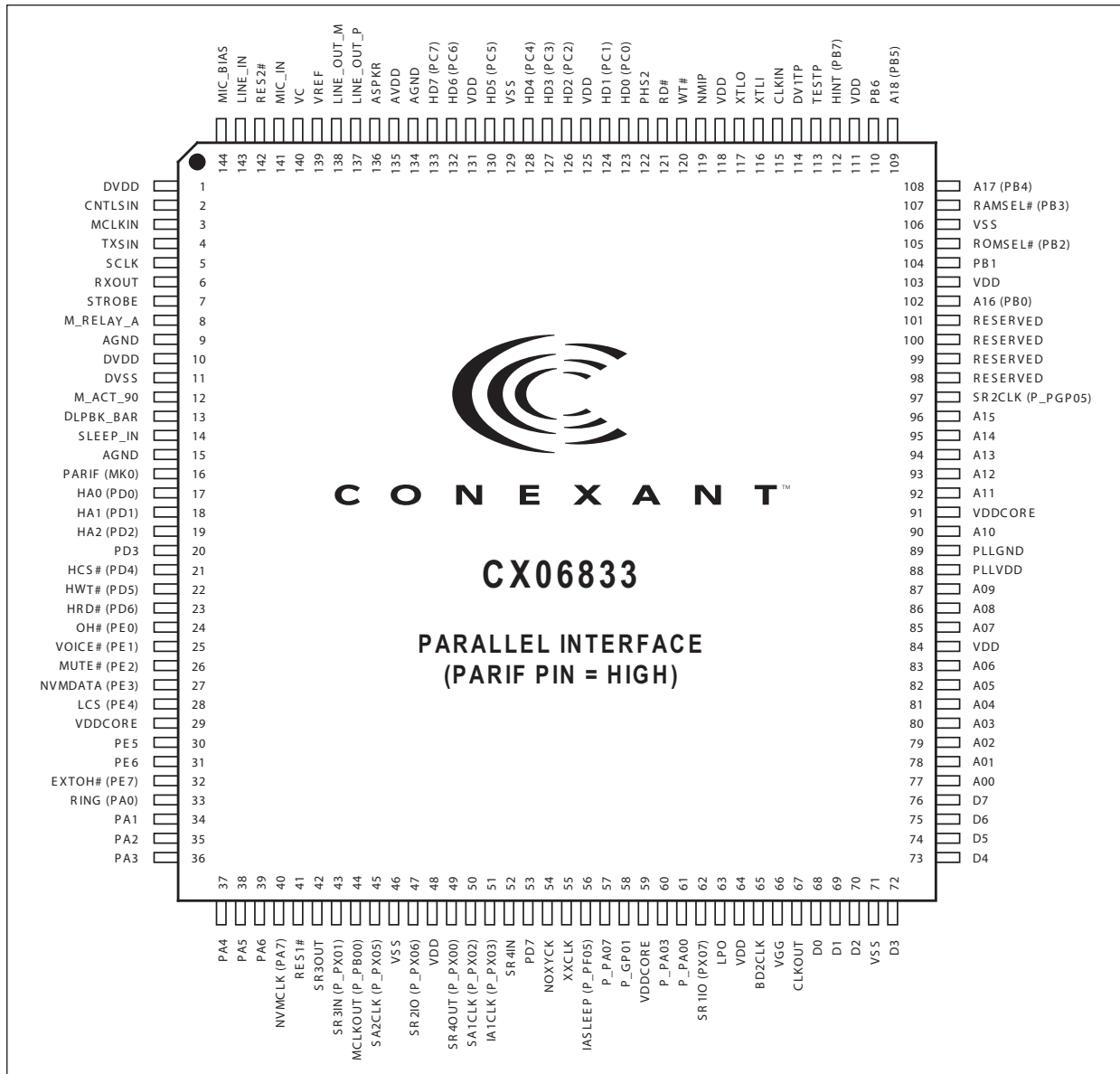

Table 4. CX06833 144-Pin TQFP Pin Signals for Parallel Interface (PARIF = High (1 of 3))

Pin	Signal Label	I/O	Interface	Pin	Signal Label	I/O	Interface
1	DVDD	P	+3.3V	73	D4	I/O	EB: D4
2	CNTLSIN	I	CX06833: SR1IO	74	D5	I/O	EB: D5
3	MCLKIN	I	CX06833: MCLKOUT through 33 Ω	75	D6	I/O	EB: D6
4	TXSIN	I	CX06833: SR4OUT	76	D7	I/O	EB: D7
5	SCLK	O	CX06833: IA1CLK through 33 Ω	77	A00	O	EB: A00
6	RXOUT	O	CX06833: SR4IN	78	A01	O	EB: A01
7	STROBE	O	CX06833:SA1CLK through 33 Ω	79	A02	O	EB: A02
8	M_RELAY_A	O	NC	80	A03	O	EB: A03
9	AGND	G	AGND	81	A04	O	EB: A04
10	DVDD	P	+3.3V	82	A05	O	EB: A05
11	DVSS	G	GND	83	A06	O	EB: A06
12	M_ACT_90	I	NC	84	VDD	P	+3.3V
13	DLPBK_BAR	I	NC	85	A07	O	EB: A07
14	SLEEP_IN	I	CX06833: IASLEEP	86	A08	O	EB: A08
15	AGND	G	AGND	87	A09	O	EB: A09
16	PARIF (MK0)	I	NC (Parallel Host)	88	PLLVDD	P	+3.3V and to GND through 1 μ F
17	HA0 (PD0)	I	HB: HA0	89	PLLGND	G	GND
18	HA1 (PD1)	I	HB: HA1	90	A10	O	EB: A10
19	HA2 (PD2)	I	HB: HA2	91	VDDCORE	P	Filter capacitors to GND
20	PD3	I	+3.3V through 47 K	92	A11	O	EB: A11
21	HCS# (PD4)	I	HB: CS#	93	A12	O	EB: A12
22	HWT# (PD5)	I	HB: WT#	94	A13	O	EB: A13
23	HRD# (PD6)	I	HB: RD#	95	A14	O	EB: A14
24	OH# (PE0)	O	DAA: Off-Hook Relay Circuit	96	A15	O	EB: A15
25	VOICE# (PE1)	O	DAA: Voice Relay Circuit (Optional)	97	SR2CLK (P_PGP05)	I	VC: M_SCK
26	MUTE# (PE2)	O	DAA: Mute Circuit (Optional)	98	RESERVED	I/O	NC

Table 4. CX06833 144-Pin TQFP Pin Signals for Parallel Interface (PARIF = High (2 of 3))

Pin	Signal Label	I/O	Interface	Pin	Signal Label	I/O	Interface
27	NVMDATA (PE3)	I/O	EEPROM: SDA	99	RESERVED	O	NC
28	LCS (PE4)	I	DAA: Line Current Sense Circuit	100	RESERVED	O	NC
29	VDDCORE	P	Filter capacitors to GND	101	RESERVED	O	NC
30	PE5	I	+3.3V through 47 K	102	A16 (PB0)	O	EB: A16
31	PE6	I/O	NC	103	VDD	P	+3.3V
32	EXTOH# (PE7)	I	DAA: Extension Pickup Circuit (Optional)	104	PB1	I/O	NC
33	RING (PA0)	I	DAA: Ring Detect Circuit	105	ROMSEL# (PB2)	O	EB: ROM CE#
34	PA1	I/O	NC	106	GND	G	GND
35	PA2	I/O	NC	107	RAMSEL# (PB3)	O	EB: RAM CS#
36	PA3	I/O	NC	108	A17 (PB4)	O	EB: A17
37	PA4	I/O	NC	109	A18 (PB5)	O	EB: A18
38	PA5	I/O	NC	110	PB6	I/O	NC
39	PA6	I/O	NC	111	VDD	P	+3.3V
40	NVMCLK (PA7)	O	EEPROM: SCL	112	HINT (PB7)	O	HB: HINT
41	RES1#	I	HB: RESET#	113	TESTP	I	NC
42	SR3OUT	O	VC: M_TXSIN	114	DV1TP	I	Clock Select
43	SR3IN (P_PX01)	I	VC: M_RXOUT	115	CLKIN	I	NC
44	MCLKOUT (P_PB00)	O	Through 33 Ω to CX06833:MCLKIN and VC: M_CLKIN	116	XTLI	I	Crystal Circuit
45	SA2CLK (P_PX05)	I	VC: M_STROBE	117	XTLO	O	Crystal Circuit
46	GND	G	GND	118	VDD	P	+3.3V
47	SR2IO (P_PX06)	O	VC: M_CNTRLSIN	119	NMIP	I	+3.3V
48	VDD	P	+3.3V	120	WT#	O	EB: WRITE#
49	SR4OUT (P_PX00)	O	CX06833: TXSIN	121	RD#	O	EB: READ#
50	SA1CLK (P_PX02)	I	CX06833: STROBE through 33	122	PHS2	O	NC
51	IA1CLK (P_PX03)	I	CX06833: SCLK through 33 Ω	123	HD0 (PC0)	I/O	HB: HD0

Table 4. CX06833 144-Pin TQFP Pin Signals for Parallel Interface (PARIF = High (3 of 3))

Pin	Signal Label	I/O	Interface	Pin	Signal Label	I/O	Interface
52	SR4IN	I	CX06833: RXOUT	124	HD1 (PC1)	I/O	HB: HD1
53	PD7	I/O	NC	125	VDD	P	+3.3V
54	NOXYCK	I	GND	126	HD2 (PC2)	I/O	HB: HD2
55	XXCLK	O	NC	127	HD3 (PC3)	I/O	HB: HD3
56	IASLEEP (P_PF05)	O	VC: SLEEP	128	HD4 (PC4)	I/O	HB: HD4
57	P_PA07	O	NC	129	GND	G	GND
58	P_GP01	I	NC	130	HD5 (PC5)	I/O	HB: HD5
59	VDDCORE	P	Filter capacitors to GND	131	VDD	P	+3.3V
60	P_PA03	O	NC	132	HD6 (PC6)	I/O	HB: HD6
61	P_PA00	I/O	NC	133	HD7 (PC7)	I/O	HB: HD7
62	SR1IO (P_PX07)	O	CX06833: CNTLSIN	134	AGND	G	AGND
63	LPO	I	+3.3V through 240K	135	AVDD	P	+3.3VA (Filtered)
64	VDD	P	+3.3V	136	ASPKR	O	AI: Speaker Circuit
65	BD2CLK	O	NC	137	LINE_OUT_P	O	DAA: TXAP
66	VGG	R	+5V or +3.3V	138	LINE_OUT_M	O	DAA: TXAM
67	CLKOUT	O	NC	139	VREF	R	AGND through C circuit
68	D0	I/O	EB: D0	140	VC	R	AGND through C circuit
69	D1	I/O	EB: D1	141	MIC_IN	I	DAA: RXA
70	D2	I/O	EB: D2	142	RES2#	I	HB: RESET#
71	GND	G	GND	143	LINE_IN	I	NC
72	D3	I/O	EB: D3	144	MIC_BIAS	O	NC

Figure 6. CX06833 Hardware Signals for Serial Interface (PARIF = Low)

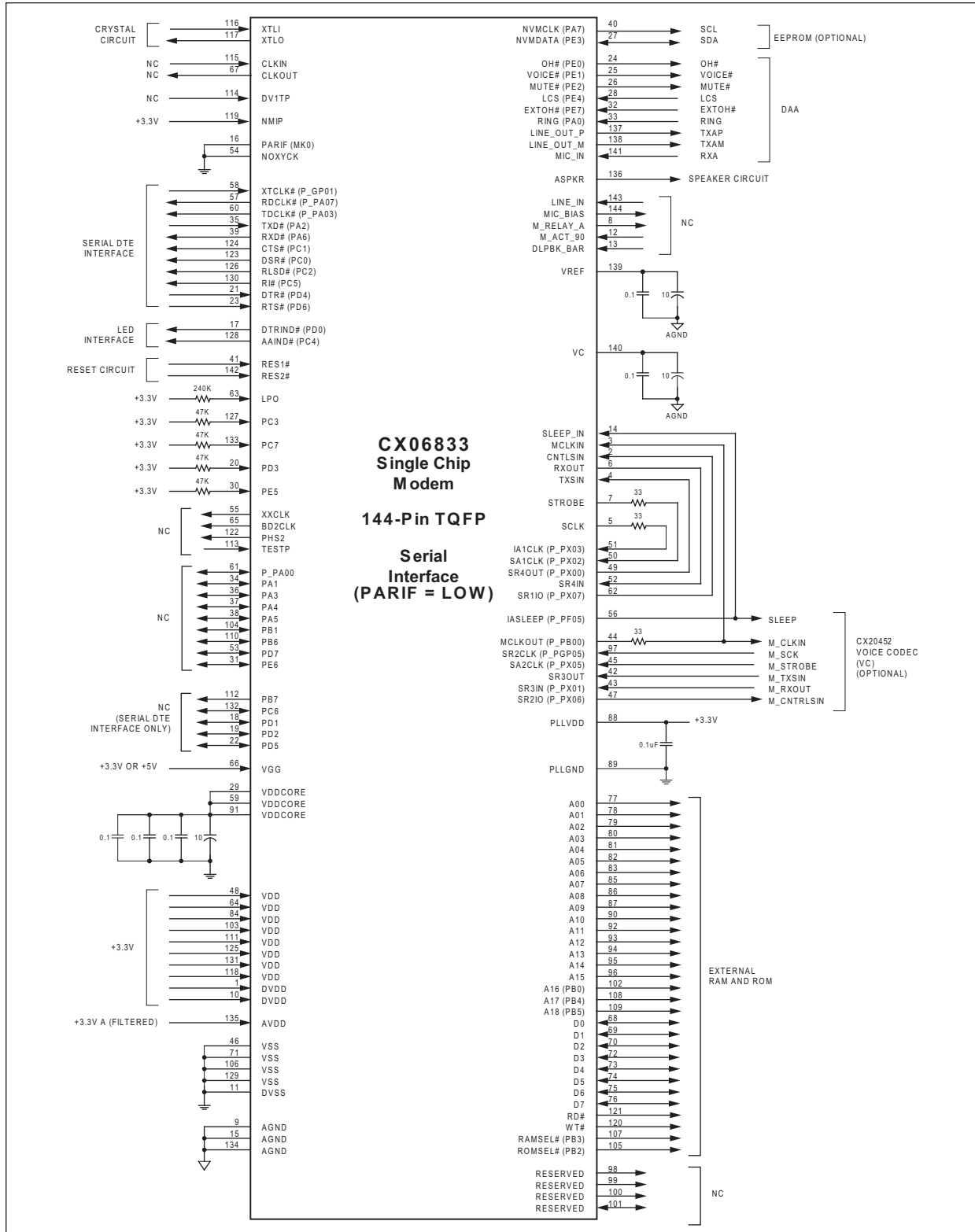

Figure 7. CX06833 144-Pin TQFP Pin Signals for Serial Interface (PARIF = Low)

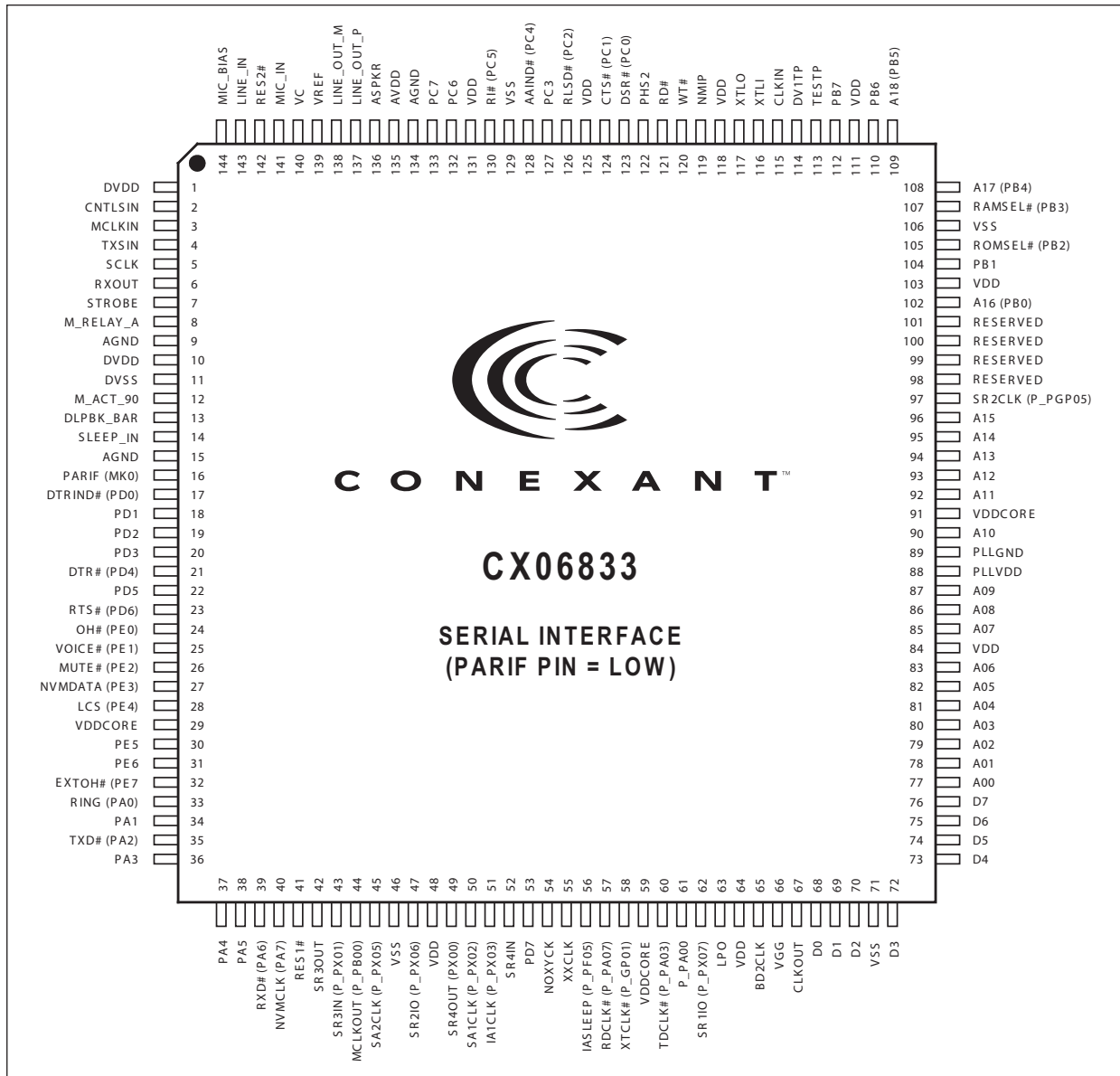

Table 5. CX06833 144-Pin TQFP Pin Signals for Serial Interface (PARIF = Low)

Pin	Signal Label	I/O	Interface	Pin	Signal Label	I/O	Interface
1	DVDD	P	+3.3V	73	D4	I/O	EB: D4
2	CNTLSIN	I	CX06833: SR1IO	74	D5	I/O	EB: D5
3	MCLKIN	I	CX06833: MCLKOUT through 33 Ω	75	D6	I/O	EB: D6
4	TXSIN	I	CX06833: SR4OUT	76	D7	I/O	EB: D7
5	SCLK	O	CX06833: IA1CLK through 33 Ω	77	A00	O	EB: A00
6	RXOUT	O	CX06833: SR4IN	78	A01	O	EB: A01
7	STROBE	O	CX06833:SA1CLK through 33 Ω	79	A02	O	EB: A02
8	M_RELAY_A	O	NC	80	A03	O	EB: A03
9	AGND	G	AGND	81	A04	O	EB: A04
10	DVDD	P	+3.3V	82	A05	O	EB: A05
11	DVSS	G	GND	83	A06	O	EB: A06
12	M_ACT_90	I	NC	84	VDD	P	+3.3V
13	DLPBK_BAR	I	NC	85	A07	O	EB: A07
14	SLEEP_IN	I	CX06833: IASLEEP	86	A08	O	EB: A08
15	AGND	G	AGND	87	A09	O	EB: A09
16	PARIF (MK0)	I	GND (Serial DTE)	88	PLLVD	P	+3.3V and to GND through 1 μ F
17	DTRIND# (PD0)	O	LED: DTRIND#	89	PLLGND	G	GND
18	PD1	I/O	NC	90	A10	O	EB: A10
19	PD2	I/O	NC	91	VDDCORE	P	Filter capacitors to GND
20	PD3	I	+3.3V through 47 K	92	A11	O	EB: A11
21	DTR# (PD4)	I	DTE: DTR#	93	A12	O	EB: A12
22	PD5	I/O	NC	94	A13	O	EB: A13
23	RTS# (PD6)	I	DTE: RTS#	95	A14	O	EB: A14
24	OH# (PE0)	O	DAA: Off-Hook Relay Circuit	96	A15	O	EB: A15
25	VOICE# (PE1)	O	DAA: Voice Relay Circuit (Optional)	97	SR2CLK (P_PGP05)	I	VC: M_SCK
26	MUTE# (PE2)	O	DAA: Mute Circuit (Optional)	98	RESERVED	I/O	NC
27	NVMDATA (PE3)	I/O	EEPROM: SDA	99	RESERVED	O	NC

Table 5. CX06833 144-Pin TQFP Pin Signals for Serial Interface (PARIF = Low)

Pin	Signal Label	I/O	Interface	Pin	Signal Label	I/O	Interface
28	LCS (PE4)	I	DAA: Line Current Sense Circuit	100	RESERVED	O	NC
29	VDDCORE	P	Filter capacitors to GND	101	RESERVED	O	NC
30	PE5	I	+3.3V through 47 K	102	A16 (PB0)	O	EB: A16
31	PE6	I/O	NC	103	VDD	P	+3.3V
32	EXTOH# (PE7)	I	DAA: Extension Pickup Circuit (Optional)	104	PB1	I/O	NC
33	RING (PA0)	I	DAA: Ring Detect Circuit	105	ROMSEL# (PB2)	O	EB: ROM CE#
34	PA1	I/O	NC	106	GND	G	GND
35	TXD# (PA2)	I	DTE: TXD#	107	RAMSEL# (PB3)	O	EB: RAM CS#
36	PA3	I/O	NC	108	A17 (PB4)	O	EB: A17
37	PA4	I/O	NC	109	A18 (PB5)	O	EB: A18
38	PA5	I/O	NC	110	PB6	I/O	NC
39	RXD# (PA6)	O	DTE: RXD#	111	VDD	P	+3.3V
40	NVMCLK (PA7)	O	EEPROM: SCL	112	PB7	O	NC
41	RES1#	I	Reset Circuit	113	TESTP	I	NC
42	SR3OUT	O	VC: M_TXSIN	114	DV1TP	I	Clock Select
43	SR3IN (P_PX01)	I	VC: M_RXOUT	115	CLKIN	I	NC
44	MCLKOUT (P_PB00)	O	Through 33 Ω to CX06833:MCLKIN and VC: M_CLKIN	116	XTLI	I	Crystal Circuit
45	SA2CLK (P_PX05)	I	VC: M_STROBE	117	XTLO	O	Crystal Circuit
46	GND	G	GND	118	VDD	P	+3.3V
47	SR2IO (P_PX06)	O	VC: M_CNTRLSIN	119	NMIP	I	+3.3V
48	VDD	P	+3.3V	120	WT#	O	EB: WRITE#
49	SR4OUT (P_PX00)	O	CX06833: TXSIN	121	RD#	O	EB: READ#
50	SA1CLK (P_PX02)	I	CX06833: STROBE through 33 Ω	122	PHS2	O	NC
51	IA1CLK (P_PX03)	I	CX06833: SCLK through 33 Ω	123	DSR# (PC0)	O	DTE: DSR#

Table 5. CX06833 144-Pin TQFP Pin Signals for Serial Interface (PARIF = Low)

Pin	Signal Label	I/O	Interface	Pin	Signal Label	I/O	Interface
52	SR4IN	I	CX06833: RXOUT	124	CTS# (PC1)	O	DTE: CTS#
53	PD7	I/O	NC	125	VDD	P	+3.3V
54	NOXYCK	I	GND	126	RLSD# (PC2)	O	DTE: RLSD#
55	XXCLK	O	NC	127	PC3	I/O	+3.3V through 47 K
56	IASLEEP (P_PF05)	O	VC: SLEEP	128	AAIND# (PC4)	O	LED: AAIND#
57	RDCLK# (P_PA07)	O	DTE: RDCLK#	129	GND	G	GND
58	XTCLK# (P_GP01)	I	DTE: XTCLK#	130	RI# (PC5)	O	DTE: RI#
59	VDDCORE	P	Filter capacitors to GND	131	VDD	P	+3.3V
60	TDCLK# (P_PA03)	O	DTE: TDCLK#	132	PC6	I/O	NC
61	P_PA00	I/O	NC	133	PC7	I/O	+3.3V through 47 K
62	SR1IO (P_PX07)	O	CX06833: CNTLSIN	134	AGND	G	AGND
63	LPO	I	+3.3V through 240K	135	AVDD	P	+3.3VA (Filtered)
64	VDD	P	+3.3V	136	ASPKR	O	AI: Speaker Circuit
65	BD2CLK	O	NC	137	LINE_OUT_P	O	DAA: TXAP
66	VGG	R	+5V or +3.3V	138	LINE_OUT_M	O	DAA: TXAM
67	CLKOUT	O	NC	139	VREF	R	AGND through C circuit
68	D0	I/O	EB: D0	140	VC	R	AGND through C circuit
69	D1	I/O	EB: D1	141	MIC_IN	I	DAA: RXA
70	D2	I/O	EB: D2	142	RES2#	I	
71	GND	G	GND	143	LINE_IN	I	NC
72	D3	I/O	EB: D3	144	MIC_BIAS	O	NC

Table 6. CX06833 Pin Signal Definitions (1 of 8)

Label	Pin	I/O	I/O Type	Signal Name/Description
Common to Parallel Host and Serial DTE Interface Configurations				
System				
XTLI, XTLO	116, 117	I, O	Ix, Ox	Crystal In and Crystal Out. If an external 28.224 MHz crystal circuit is used instead of an external clock circuit, connect XTLI and XTLO to the external crystal circuit and leave CLKIN open.
CLKIN	115	I	It	Clock In. If an external 28.224 MHz clock circuit is used instead of an external crystal circuit, connect CLKIN to the clock output and leave XTLI and XTLO open.
CLKOUT	67	O	It/Ot2	Clock Out. 28.224 MHz output clock. Leave open.
DV1TP	114	I	Itpu	Clock Input Select. This input is used to choose the clock input. Connect to +3.3V or leave open to select XTLI as the clock input. Connect to GND to select CLKIN as the clock input.
NOXYCK	54			
PARIF	16	I	Itpu	Parallel/Serial Interface Select. PARIF input high (open) selects parallel host interface operation. PARIF low (GND) selects serial DTE interface operation.
NMI#	119	I	Itphu	Non-Maskable Interrupt. Not used. Connect to +3.3V.
RES1# RES2#	41 142	I	It	Reset. The active low RES1# and RES2# input resets the CX06833 logic, and restores the saved configuration from serial EEPROM or returns the modem to the factory default values if EEPROM is not present. RESET# low holds the modem in the reset state; RESET# going high releases the modem from the reset state. After application of VDD, RESET# must be held low for at least 15 ms after the VDD power reaches operating range. The modem device set is ready to use 25 ms after the low-to-high transition of RESET#. For parallel Interface, connect RESET# input to the host bus RESET line through an inverter. For serial Interface, connect RESET# input to a reset switch circuit.
Power and Ground				
VGG	66	P	PWRG	I/O Signaling Voltage Source. Connect to +5V or +3.3V.
VDD	48, 64, 84, 103, 111, 118, 125, 131	P	PWR	Digital Supply Voltage for Digital Circuits. Connect to +3.3V.
DVDD	1, 10	P	PWR	Digital Supply Voltage for Analog Circuits. Connect to +3.3V
AVDD	135	P	PWR	Analog Supply Voltage for Analog Circuits. Connect to analog power.
VSS	46, 71, 106, 129	G	GND	Digital Ground for Digital Circuits. Connect to digital ground.
DVSS	11	G	GND	Digital Ground for Analog Circuits. Connect to digital ground.

Table 6. CX06833 Pin Signal Definitions (2 of 8)

Label	Pin	I/O	I/O Type	Signal Name/Description
Common to Parallel Host and Serial DTE Interface Configurations				
Power and Ground (continued)				
AGND	9, 15, 134	G	AGND	Analog Ground for Analog Circuits. Connect to analog ground.
VDDCORE	29, 59, 91	P	PWR	Core Voltage. +1.8V internally generated by a voltage regulator connected to the VDD input pins. VDDCORE is routed externally for decoupling to GND through capacitors.
PLLVD	88	P	PWR	Supply Voltage for PLL Circuit. Connect to +3.3V and to analog ground through 0.1 μ F.
PLLGND	89	G	GND	Digital Ground for PLL Circuit. Connect to digital ground.
Serial EEPROM (EEPROM) Interface				
NVMCLK (PA7)	40	O	It/Ot2	EEPROM Clock. NVMCLK output high enables the EEPROM. Connect to the EEPROM SCL pin.
NVMDATA (PE3)	27	I/O	It/Ot2	EEPROM Data. NVMDATA supplies serial data to and from the EEPROM. Connect to the EEPROM SDA pin and to +3.3V through 10 K Ω .
External Bus Interface				
A00-A06, A07-A09, A10 A11-A15, A16 (PB0), A17 (PB4), A18 (PB5)	77-83, 85-87, 90, 92-96, 102, 108, 109	O, O, O, O, O, O, O	It/Ot8, It/Ot8, It/Ot2, It/Ot2, It/Ot2, It/Ot2, It/Ot2	Address Lines 0-18. A0-A18 are the address output lines used to access external memory; up to 4 Mbits (512k bytes) flash ROM using A0-A18 and up to 1 Mbit (128k bytes) RAM using A0-A16.
D0-D2, D3-D7	68-70, 72-76	I/O	It/Ot2	Data Line 0-7. D0-D7 are bidirectional external memory bus data lines.
READ#	121	O	It/Ot2	Read Enable. READ# output low enables data transfer from the selected device to the D0-D7 lines.
WRITE#	120	O	It/Ot2	Write Enable. WRITE# output low enables data transfer from the D0-D7 lines to the selected device.
RAMSEL# (PB3)	107	O	It/Ot2	RAM Select. RAMSEL# output low selects the external RAM.
ROMSEL# (PB2)	105	O	Ot2	ROM Select. ROMSEL# output low selects the external flash ROM.

Table 6. CX06833 Pin Signal Definitions (3 of 8)

Label	Pin	I/O	I/O Type	Signal Name/Description
Common to Parallel Host and Serial DTE Interface Configurations				
Telephone Line/Telephone/Audio Interface Signals and Reference Voltage				
OH# (PE0)	24	O	It/Ot2	Off-Hook Relay Control. The active low output can be used to control the normally open off-hook relay.
VOICE# (PE1)	25	O	It/Ot2	Voice Relay Control. The active low VOICE# output can optionally be used to switch the handset from the telephone line to the voice codec interface to be used as a microphone and speaker. Leave open if not used.
MUTE# (PE2)	26	O	It/Ot2	Mute Relay Control. The active low MUTE# output can optionally be used to control the normally open mute relay. Leave open if not used.
LCS (PE4)	28	I	It/Ot2	Loop Current Sense. LCS is an active high input that indicates a handset off-hook status.
EXTOH# (PE7)	32	I	It/Ot2	Extension Off-Hook. Active low input optionally used to indicate when the telephone handset connected to the modem goes off-hook state. Connect to +3.3V through 47K if not used.
RING (PA0)	33	I	It/Ot2	Ring Frequency. A rising edge on the RING input initiates an internal ring frequency measurement. The RING input from an external ring detect circuit is monitored to determine when to wake up from sleep or stop mode. The RING input is typically connected to the output of an opto isolator or equivalent. The idle state (no ringing) output of the ring detect circuit should be low.
LINE_OUT_P, LINE_OUT_M	137, 138	O, O	O(DF)	Transmit Analog 1 and 2. The LINE_OUT_P and LINE_OUT_M outputs are differential outputs 180 degrees out of phase with each other. Each output can drive a 300 Ω load. Connect LINE_OUT_P and LINE_OUT_M to the DAA telephone line interface transmit circuit.
MIC_IN	141	I	I(DA)	Receive Analog. MIC_IN is a single-ended input from the telephone line interface or an optional external hybrid circuit with 70K Ω input impedance. Connect MIC_IN to the DAA telephone line interface receive circuit.
VREF	139	R	REF	High Voltage Reference. Connect to AGND through 10 μ F (polarized, + terminal to VREF) and 0.1 μ F (ceramic) in parallel. Ensure a very close proximity between these capacitors and VREF pin. Use a short path and a wide trace to AGND pin.
VC	140	R	REF	Low Voltage Reference. Connect to AGND through 10 μ F (polarized, + terminal to VC) and 0.1 μ F (ceramic) in parallel. Ensure a very close proximity between these capacitors and VC pin. Use a short path and a wide trace to AGND pin.
ASPKR	136	O	O(DF)	Speaker Analog Output. The ASPKR analog output can originate from one of five different sources: RIN, TELIN, MICM or MICV or from the MDP's internal voice playback mode. The ASPKR on/off and three levels of attenuation are controlled by bits in DSP RAM. When the speaker is turned off, the ASPKR output is clamped to the voltage at the VC pin. The ASPKR output can drive an impedance as low as 300 Ω . In a typical application, the ASPKR output is an input to an external LM386 audio power amplifier.
LINE_IN	143	I	I(DA)	Not Used. Leave open.
MIC_BIAS	144	O	Oa	Not Used. Leave open.

Table 6. CX06833 Pin Signal Definitions (4 of 8)

Label	Pin	I/O	I/O Type	Signal Name/Description
Common to Parallel Host and Serial DTE Interface Configurations				
Telephone Line/Telephone/Audio Interface Signals and Reference Voltage (Continued)				
M_RELAYA	8	O	Ot	Not Used. Leave open.
M_ACT90	12	I	Itpu	Not Used. Leave open.
DLPBK_BAR	13	I	It	Not Used. Leave open.
CX06833 Interconnect and Optional CX20452 VC Interface				
SLEEP_IN	14	I	Itpd	Modem Codec Sleep In. Connect to CX06833: IASLEEP pin.
MCLKIN	3	I	lpd	Modem Codec Serial Clock In. Connect to CX06833: MCLKOUT pin through 33 Ω.
CNTLSIN	2	I	Itpd	Modem Codec Serial Control In. Connect to CX06833: SR1IO pin.
RXOUT	6	O	Ot2	Modem Codec Serial Receive Data Out. Connect to CX06833: SR4IN pin.
TXSIN	4	I	Itpd	Modem Codec Serial Transmit Data In. Connect to CX06833: SR4OUT pin.
STROBE	7	O	Ot2	Modem Codec Serial Frame Sync Out. Connect to CX06833: SA1CLK pin through 33 Ω.
SCLK	5	O	Ot2	Modem Codec Serial Clock Out. Connect to CX06833: IA1CLK pin through 33 Ω.
IA1CLK (P_PX03)	51	I	Itpu/Ot2	DSP Modem Serial Clock In. Connect to CX06833: SCLK pin through 33 Ω.
SA1CLK (P_PX02)	50	I	Itpu/Ot2	DSP Modem Serial Frame Sync In. Connect to CX06833: STROBE pin through 33 Ω.
SR4OUT (P_PX00)	49	O	Itk/Ot2	DSP Modem Serial Transmit Data Out. Connect to CX06833: TXSIN pin.
SR4IN	52	I	Itk/Ot2	DSP Modem Serial Receive Data In. Connect to CX06833: RXOUT pin.
SR1IO (P_PX07)	62	O	Itk/Ot2	DSP Modem Serial Control Out. Connect to CX06833: CNTLSIN pin.
IASLEEP (P_PF05)	56	O	Ot2	DSP Sleep Out. Connect to CX06833: SLEEP_IN pin and to VC SLEEP pin.
M_CLKOUT (P_PB00)	44	O	It/Ot2	DSP Master Serial Clock Out. Connect through 33 Ω to CX06833: MCLKIN pin and to VC M_CLKIN pin.
SR2CLK (P_PGP05)	97	I	Itpu/Ot2	DSP Voice Serial Clock In. Connect to VC M_SCK pin. Leave open if VC is not installed.
SA2CLK (P_PX05)	45	I	Itpu/Ot2	DSP Voice Serial Frame Sync In. Connect to VC M_STROBE pin. Leave open if VC is not installed.
SR3OUT	42	O	Ot2	DSP Voice Serial Transmit Data Out. Connect to VC M_TXSIN pin. Leave open if VC is not installed.
SR3IN (P_PX01)	43	I	Itk/Ot2	DSP Voice Serial Receive Data In. Connect to VC M_RXOUT pin. Leave open if VC is not installed.
SR2IO (P_PX06)	47	O	It/Ot2	DSP Voice Serial Control Out. Connect to VC M_CNTRLSIN pin. Leave open if VC is not installed.

Table 6. CX06833 Pin Signal Definitions (5 of 8)

Label	Pin	I/O	I/O Type	Signal Name/Description
Common to Parallel Host and Serial DTE Interface Configurations				
Not Used – Connect to +3.3V through Resistor				
LPO	63	I	I/O	Low Power Oscillator. Not used. Connect to +3.3V through 240 K Ω .
PC3	127	I	Ith/Ot2	Port PC3. Not used. Connect to +3.3V through 47K Ω .
PC7	133	I	Ith/Ot2	Port PC7. Not used. Connect to +3.3V through 47K Ω .
PD3	20	I	Ith/Ot2	Port PD7. Not used. Connect to +3.3V through 47K Ω .
PE5	30	I	Ith/Ot2	Port PE5. Not used. Connect to +3.3V through 47K Ω .
PARALLEL HOST BUS CONFIGURATION ONLY (PARIF = HIGH)				
Parallel Host Interface				
HCS# (PD4)	21	I	It	Host Bus Chip Select. HCS# input low enables the MCU host bus interface.
HRD# (PD6)	23	I	Ithpu	Host Bus Read. HRD# is an active low, read control input. When HCS# is low, HRD# low allows the host to read status information or data from a selected MCU register.
HWT# (PD5)	22	I	Ithpu	Host Bus Write. HWT# is an active low, write control input. When HCS# is low, HWT# low allows the host to write data or control words into a selected MCU register.
HINT (PB7)	112	O	It/Ot8	Host Bus Interrupt. HINT output is set high when the receiver error flag, received data available, transmitter holding register empty, or modem status interrupt is asserted. HINT is reset low upon the appropriate interrupt service or master reset operation.
HA0-HA2 (PD0-PD2)	17-19	I	Ithpd/Ot2	Host Bus Address Lines 0-2. During a host read or write operation with HCS# low, HA0-HA2 select an internal MCU 16550A-compatible register.
HD0-HD7 (PC0-PC7)	123-124, 126-128, 130-133	I/O	Ith/Ot8	Host Bus Data Lines 0-7. HD0-HD7 are three-state input/output lines providing bidirectional communication between the host and the MCU. Data, control words, and status information are transferred over HD0-HD7.
Not Used (In Parallel Host Interface Configuration)				
BD2CLK	65	O	Itpu/Ot2	Not Used. Leave open.
DV1TP	114	I	Itpu	Not Used. Leave open.
PHS2	122	O	Ot2	Not Used. Leave open.
TESTP	113	I	Itpu	Not Used. Leave open.
XXCLK	55	O	It/Ot2	Not Used. Leave open.
P_GP01	58	I	It	Port P_GP01. Leave open.
P_PA00	61	I/O	Itpu/Ot2	Port P_PA00. Leave open.

Table 6. CX06833 Pin Signal Definitions (6 of 8)

Label	Pin	I/O	I/O Type	Signal Name/Description
Common to Parallel Host and Serial DTE Interface Configurations				
Not Used (In Parallel Host Interface Configuration) (continued)				
P_PA03	60	O	Ot2	Port P_PA03. Leave open.
P_PA07	57	O	Ot2	Port P_PA07. Leave open.
PA1	34	I/O	It/Ot2	Port PA1. Leave open.
PA2	35	I/O	It/Ot2	Port PA2. Leave open.
PA3	36	I/O	Itpu/Ot2	Port PA3. Leave open.
PA4	37	I/O	Itpu/Ot2	Port PA4. Leave open.
PA5	38	I/O	It/Ot2	Port PA5. Leave open.
PA6	39	I/O	It/Ot2	Port PA6. Leave open.
PB1	104	I/O	It/Ot2	Port PB1. Leave open.
PB6	110	I/O	It/Ot2	Port PB6. Leave open.
PD7	53	I/O	It/Ot2	Port PD7. Leave open.
PE6	31	I/O	It/Ot2	Port PE6. Leave open.
RESERVED	98-101			Reserved. Connected to internal circuitry. Leave open.
SERIAL DTE INTERFACE CONFIGURATION ONLY (PARIF = LOW)				
V.24 (EIA/TIA-232-E) DTE Serial Interface				
XTCLK# (P_GP01)	58	I	It/Ot2	External Data Clock. Synchronous External Transmit Data Clock input in synchronous modes. Leave open if not used.
RDCLK# (P_PA07)	57	O	Itpu/Ot2	Receive Data Clock. Synchronous Receive Data Clock output in synchronous modes. The RDCLK frequency is the data rate ($\pm 0.01\%$) with a duty cycle of $50\pm 1\%$. Leave open if not used.
TDCLK# (P_PA03)	60	O	Itpu/Ot2	Transmit Data Clock. Synchronous Transmit Data Clock output in synchronous modes. The TDCLK# frequency is the data rate ($\pm 0.01\%$) with a duty cycle of $50\pm 1\%$. Leave open if not used.
TXD# (PA2)	35	I	It/Ot2	Transmitted Data (EIA BA/ITU-T CT103). The DTE uses the TXD# line to send data to the modem for transmission over the telephone line or to transmit commands to the modem.
RXD# (PA6)	39	O	It/Ot2	Received Data (EIA BB/ITU-T CT104). The modem uses the RXD# line to send data received from the telephone line to the DTE and to send modem responses to the DTE. During command mode, RXD# data represents the modem responses to the DTE.

Table 6. CX06833 Pin Signal Definitions (7 of 8)

Label	Pin	I/O	I/O Type	Signal Name/Description
Common to Parallel Host and Serial DTE Interface Configurations				
CTS# (PC1)	124	O	lth/Ot8	Clear To Send (EIA CB/ITU-T CT106). CTS# output ON (low) indicates that the modem is ready to accept data from the DTE. In asynchronous operation, in error correction or normal mode, CTS# is always ON (low) unless RTS/CTS flow control is selected by the &Kn command. In synchronous operation, the modem also holds CTS# ON during asynchronous command state. The modem turns CTS# OFF immediately upon going off-hook and holds CTS# OFF until both DSR# and RLSD# are ON and the modem is ready to transmit and receive synchronous data. The modem can also be commanded by the &Rn command to turn CTS# ON in response to an RTS# OFF-to-ON transition.
DSR# (PC0)	123	O	lth/Ot8	Data Set Ready (EIA CC/ITU-T CT107). DSR# indicates modem status to the DTE. DSR# OFF (high) indicates that the DTE is to disregard all signals appearing on the interchange circuits except Ring Indicator (RI#). DSR# output is controlled by the AT&Sn command.
RLSD# (PC2)	126	O	lth/Ot8	Received Line Signal Detector (EIA CF/ITU-T CT109). When AT&C0 command is not in effect, RLSD# output is ON when a carrier is detected on the telephone line or OFF when carrier is not detected.
RI# (PC5)	130	O	lth/Ot8	Ring Indicator (EIA CE/ITU-T CT125). RI# output ON (low) indicates the presence of an ON segment of a ring signal on the telephone line.
DTR# (PD4)	21	I	lt	Data Terminal Ready (EIA CD/ITU-T CT108). The DTR# input is turned ON (low) by the DTE when the DTE is ready to transmit or receive data. DTR# ON prepares the modem to be connected to the telephone line, and maintains the connection established by the DTE (manual answering) or internally (automatic answering). DTR# OFF places the modem in the disconnect state under control of the &Dn and &Qn commands.
RTS# (PD6)	23	I	lthpu	Request To Send (EIA CA/ITU-T CT105). RTS# input ON (low) indicates that the DTE is ready to send data to the modem. In the command state, the modem ignores RTS#. In asynchronous operation, the modem ignores RTS# unless RTS/CTS flow control is selected by the &Kn command. In synchronous on-line operation, the modem can be commanded by the &Rn command to ignore RTS# or to respond to RTS# by turning on CTS# after the delay specified by Register S26.
LED Indicator Interface				
AAIND# (PC4)	128	O	lth/Ot8	Auto Answer Indicator. AAIND# output ON (low) corresponds to the indicator on. AAIND# output is active when the modem is configured to answer the ring automatically (ATS0 command ≠ 0).
DTRIND# (PD0)	17	O	lthpd/Ot2	DTR Indicator. DTRIND# output ON (low) corresponds to the indicator on. The DTRIND# state reflects the DTR# output state except when the &D0 command is active, in which case DTRIND# is low.

Table 6. CX06833 Pin Signal Definitions (8 of 8)

Label	Pin	I/O	I/O Type	Signal Name/Description
Common to Parallel Host and Serial DTE Interface Configurations				
Not Used (In Serial DTE Interface Configuration)				
BD2CLK	65	O	ltpu/Ot2	Not Used. Leave open.
PHS2	122	O	Ot2	Not Used. Leave open.
TESTP	113	I	ltpu	Not Used. Leave open.
XXCLK	55	O	lt/Ot2	Not Used. Leave open.
P_PA00	61	I/O	ltpu/Ot2	Port P_PA00. Leave open.
PA1	34	I/O	lt/Ot2	Port PA1. Leave open.
PA3	36	I/O	ltpu/Ot2	Port PA3. Leave open.
PA4	37	I/O	ltpu/Ot2	Port PA4. Leave open.
PA5	38	I/O	lt/Ot2	Port PA5. Leave open.
PB1	104	I/O	lt/Ot2	Port PB1. Leave open.
PB6	110	I/O	lt/Ot2	Port PB6. Leave open.
PC6	132	I/O	lth/Ot8	Port PC6. Leave open.
PD1	18	I/O	lthpd/Ot2	Port PD1. Leave open.
PD2	19	I/O	lthpd/Ot2	Port PD2. Leave open.
PD5	22	I/O	lthpu	Port PD5. Leave open.
PD7	53	I/O	lt/Ot2	Port PD7. Leave open.
PE2	26	I/O	lt/Ot2	Port PE2. Leave open.
PE6	31	I/O	lt/Ot2	Port PE6. Leave open.
RESERVED	98-101			Reserved. Connected to internal circuitry. Leave open.
GENERAL NOTES:				
1. I/O Types: See Table 7 .				
2. Interface Legend:				
EBExpansion Bus				
HBHost Bus				
NCNo internal pin connection				
VCVoice Codec				
RESERVED = No external connection allowed (may have internal connection).				

Table 7. CX06833 I/O Type Definitions

I/O Type	Description
Ix/Ox	I/O, wire
It/Ot2	Digital input, +5V tolerant/ Digital output, 2 mA, ZINT = 120 Ω
Itk/Ot2	Digital input, +5V tolerant, keeper/ Digital output, 2 mA, ZINT = 120 Ω
Itpu/Ot2	Digital input, +5V tolerant, 75k Ω pull up/ Digital output, 2 mA, ZINT = 120 Ω
It/Ot8	Digital input, +5V tolerant,/ Digital output, 8 mA, ZINT = 50 Ω
ItHPD/Ot2	Digital input, +5V tolerant, hysteresis, 75k Ω pull down/ Digital output, 2 mA, ZINT = 120 Ω
ItH/Ot2	Digital input, +5V tolerant, hysteresis/Digital output, 2 mA, ZINT = 120 Ω
ItH/Ot8	Digital input, +5V tolerant, hysteresis/Digital output, 8 mA, ZINT = 50 Ω
It	Digital input, +5V tolerant
Itk	Digital input, +5V tolerant, keeper
Itkpu	Digital input, +5V tolerant, keeper, 75k Ω pull up
Itpu	Digital input, +5V tolerant, 75k Ω pull up
ItHpu	Digital input, +5V tolerant, hysteresis, 75k Ω pull up
Ot2	Digital output, three-state, 2 mA, ZINT = 120 Ω
PWR	VCC Power
PWRG	VGG Power
GND	Ground
GENERAL NOTES:	
1. See DC characteristics in Table 8 .	
2. I/O Type corresponds to the device Pad Type. The I/O column in signal interface tables refers to signal I/O direction used in the application.	

Table 8. CX06833 DC Electrical Characteristics

Parameter	Symbol	Minimum	Typical	Maximum	Units	Test Conditions
Input Voltage Low	VIL					
+5V tolerant		0	–	0.8	V	
+5V tolerant hysteresis		0	–	0.3 *VGG	V	
Input Voltage High	VIH		–		V	
+5V tolerant		2	–	5.25	V	
+5V tolerant hysteresis		0.7 * VDD	–	5.25	V	
Input Hysteresis	VH		–		V	
+3V hysteresis		0.5	–		V	
+5V tolerant, hysteresis		0.3	–		V	
Output Voltage Low	VOL					
ZINT = 120 Ω		0	–	0.4	V	IOL = 2 mA
ZINT = 50 Ω		0	–	0.4	V	IOL = 8 mA
Output Voltage High	VOH		–		V	
ZINT = 120 Ω		2.4	–	VDD	V	IOL = -2 mA
ZINT = 50 Ω		2.4	–	VDD	V	IOL = -8 mA
Pull-Up Resistance	Rpu	50	–	200	kΩ	
Pull-Down Resistance	Rpd	50	–	200	kΩ	
GENERAL NOTES: Test Conditions unless otherwise stated: VDD = +3.3 ± 0.3 VDC; TA = 0°C to 70°C; external load = 50 pF.						

3.2 CX20452 VC Hardware Pins and Signals (S Models)

3.2.1 CX20452 VC Signal Summary

Microphone and analog speaker interface signals, as well as telephone handset/headset interface signals are provided to support functions such as speakerphone mode, telephone emulation, microphone voice record, speaker voice playback, and call progress monitor.

3.2.1.1 Speakerphone Interface

The following signals are supported:

- ◆ Speaker Out (M_SPKR_OUT); analog output - Should be used in speakerphone designs where sound quality is important
- ◆ Microphone (M_MIC_IN); analog input

3.2.1.2 Telephone Handset/Headset Interface

The following interface signals are supported:

- ◆ Telephone Input (M_LINE_IN), input (TELIN) - Optional connection to a telephone handset interface circuit
- ◆ Telephone output (M_LINE_OUTP); output (TELOUT) - Optional connection to a telephone handset interface circuit
- ◆ Center Voltage (VC); output reference voltage

3.2.1.3 CX06833 Modem Interface

The following interface signals are supported:

- ◆ Sleep (SLEEP); input
- ◆ Master Clock (M_CLKIN); input
- ◆ Serial Clock (M_SCK); output
- ◆ Control (M_CNTRLSIN); input
- ◆ Serial Frame Sync (M_STROBE); output
- ◆ Serial Transmit Data (M_TXSIN); input
- ◆ Serial Receive Data (M_RXOUT); output

3.2.1.4 Host Interface

The following interface signals are supported:

- ◆ Reset (POR); input

3.2.2 CX20452 VC Pin Assignments and Signal Definitions

VC 24-pin QFN hardware interface signals are shown by major interface in [Figure 8](#), are shown by pin number in [Figure 9](#), and are listed by pin number in [Table 9](#).

VC hardware interface signals are defined in [Table 10](#).

VC pin signal DC electrical characteristics are defined in [Table 11](#).

VC pin signal analog electrical characteristics are defined in [Table 12](#).

Figure 8. CX20452 VC Hardware Interface Signals

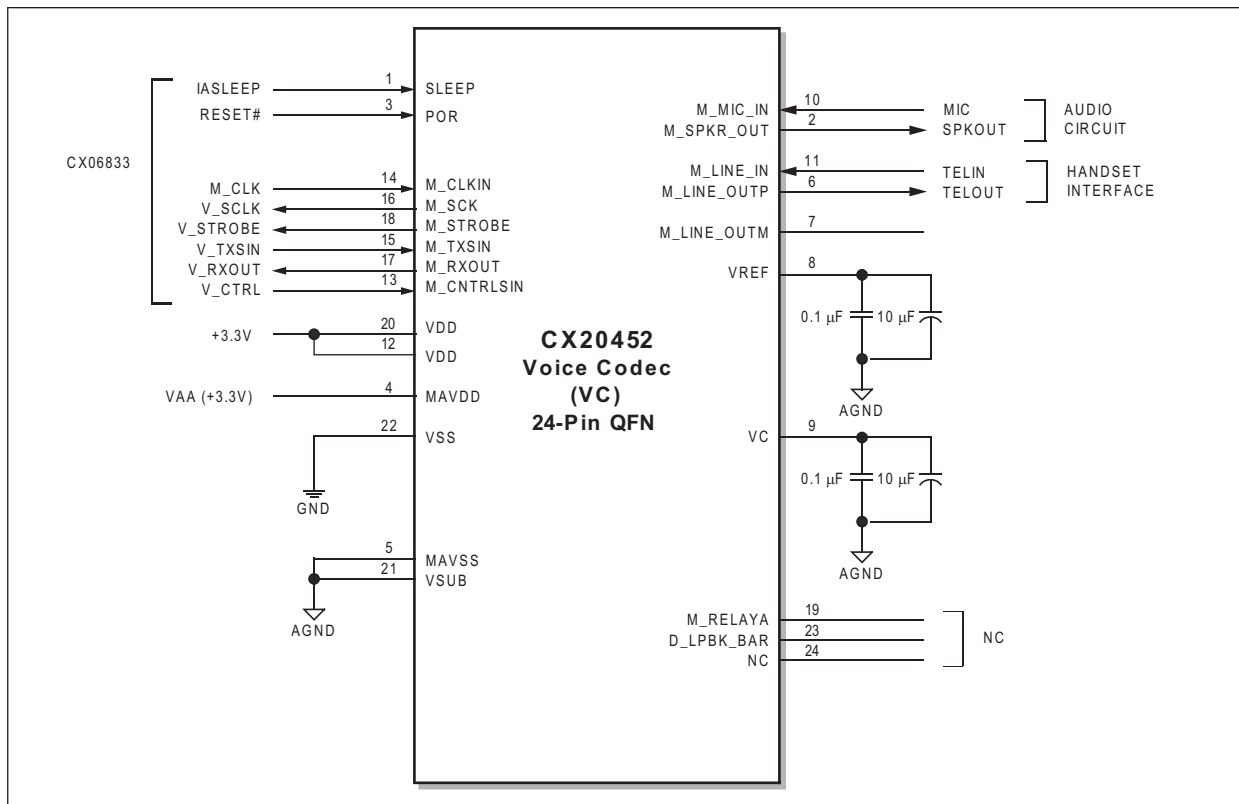

Figure 9. CX20452 VC 24-Pin QFN Pin Signals

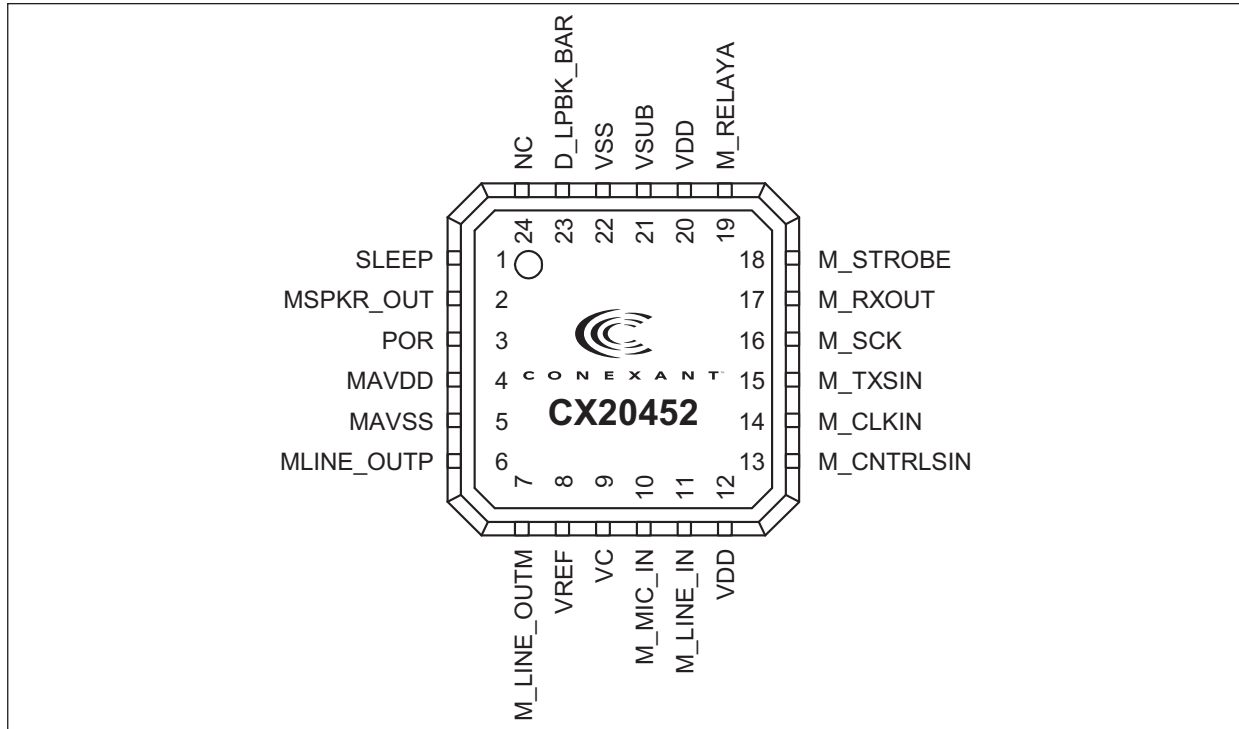

Table 9. CX20452 VC 24-Pin QFN Pin Signals

Pin	Signal Label	I/O	Interface
1	SLEEP	I	CX06833: IASLEEP
2	M_SPKR_OUT	O	Speaker interface circuit
3	POR	I	Host: RESET# or reset circuit
4	MAVDD	P	VAA (+3.3V)
5	MAVSS	G	AGND
6	M_LINE_OUTP	O	Handset interface circuit: TELOUT
7	M_LINE_OUTM	O	NC
8	VREF		AGND through capacitors
9	VC		AGND through capacitors
10	M_MIC_IN	I	Microphone interface circuit
11	M_LINE_IN	I	Handset interface circuit: TELIN
12	VDD	P	+3.3V
13	M_CNTRLSIN	I	CX06833: V_CTRL
14	M_CLKIN	I	CX06833: M_CLK
15	M_TXSIN	I	CX06833: V_TXSIN
16	M_SCK	O	CX06833: V_SCLK
17	M_RXOUT	O	CX06833: V_RXOUT
18	M_STROBE	O	CX06833: V_STROBE
19	M_RELAYA	O	NC
20	VDD	P	+3.3V
21	VSUB	G	AGND
22	VSS	G	GND
23	D_LPBK_BAR	I	NC
24	NC		NC

Table 10. CX20452 VC Pin Signal Definitions (1 of 2)

Label	Pin	I/O	I/O Type	Signal Name/Description
System Signals				
VDD	12, 20	P	PWR	Digital Power Supply. Connect to +3.3V and digital circuits power supply filter.
MAVDD	4	P	PWR	Analog Power Supply. Connect to +3.3V and analog circuits power supply filter.
VSS	22	G	GND	Digital Ground. Connect to GND.
MAVSS	5	G	AGND	Analog Ground. Connect to AGND.
VSUB	21	G	GND	Analog Ground. Connect to AGND.
POR	3	I	ltpu	Power-On Reset. Active low reset input. Connect to Host RESET# or reset circuit.
CX06833 Interconnect				
SLEEP	1	I	ltpd	IA Sleep. Active high sleep input. Connect to CX06833 IASLEEP pin.
M_CLKIN	14	I	ltpd	Master Clock Input. Connect to CX06833 M_CLK pin.
M_SCK	16	O	Ot2	Serial Clock Output. Connect to CX06833 V_SCLK pin.
M_CNTRL_SIN	13	I	ltpd	Control Input. Connect to CX06833 V_CTRL pin.
M_STROBE	18	O	Ot2	Serial Frame Sync. Connect to CX06833 V_STROBE pin.
M_TXSIN	15	I	ltpd	Serial Transmit Data. Connect to CX06833 V_TXSIN pin.
M_RXOUT	17	O	Ot2	Serial Receive Data. Connect to CX06833 V_RXOUT pin.
Microphone/Speaker Interface				
M_MIC_IN	10	I	I(DA)	Microphone Input. Single-ended analog input from the microphone circuit.
M_SPKR_OUT	2	O	O(DF)	Modem Speaker Analog Output. The M_SPKR_OUT analog output reflects the received analog input signal. The M_SPKR_OUT on/off and three levels of attenuation are controlled by bits in DSP RAM. When the speaker is turned off, the M_SPKR_OUT output is clamped to the voltage at the VC pin. The M_SPKR_OUT output can drive an impedance as low as 300 Ω . In a typical application, the M_SPKR_OUT output is an input to an external LM386 audio power amplifier.
Handset/Headset Interface				
M_LINE_OUTP	6	O	O(DF)	Telephone Handset Out (TELOUT). Single-ended analog data output to the telephone handset circuit. The output can drive a 300 Ω load.
M_LINE_IN	11	I	I(DA)	Telephone Handset Out (TELIN). Single-ended analog data input from the telephone handset circuit.

Table 10. CX20452 VC Pin Signal Definitions (2 of 2)

Label	Pin	I/O	I/O Type	Signal Name/Description
Reference Voltage				
VREF	8	R	REF	High Voltage Reference. Connect to analog ground through 10 μ F (polarized, + terminal to VREF) and 0.1 μ F (ceramic) in parallel. Ensure a very close proximity between these capacitors and VREF pin.
VC	9	R	REF	Low Voltage Reference. Connect to analog ground through 10 μ F (polarized, + terminal to VC) and 0.1 μ F (ceramic) in parallel. Ensure a very close proximity between these capacitors and VC pin. For handset interface, also connect to handset interface circuit (VC_HAND).
Not Used				
M_RELAYA	19	O	Ot	Not Used. Leave open.
D_LPBK_BAR	23	I	It	Not Used. Leave open.
NC	24			Internal No Connect. Leave open.
GENERAL NOTES:				
I/O types:				
IaAnalog input				
ItDigital input, TTL-compatible				
ItpdDigital input, TTL-compatible, internal 75k \pm 25k Ω pull-down				
ItpuDigital input, TTL-compatible, internal 75k \pm 25k Ω pull-up				
OaAnalog output				
Ot2 Digital output, TTL-compatible, 2 mA, ZINTERNAL = 120 Ω				
Ot2od Digital output, TTL-compatible, 2 mA, open drain, ZINTERNAL = 120				
AGND Analog Ground				
GNDDigital Ground				

Table 11. CX20452 VC DC Electrical Characteristics

Parameter	Symbol	Minimum	Typical	Maximum	Units	Test Conditions
Input Voltage	VIN	-0.30	–	VDD+0.3	V	
Input Voltage Low	VIL	-0.30	–	0.2 *VDD	V	
Input Voltage High	VIH	0.4*VDD	–	VDD+0.3	V	
Output Voltage Low	VOL	0	–	0.4	V	
Output Voltage High	VOH	0.8*VDD	–	VDD	V	
Input Leakage Current	–	-10	–	10	μ A	
Output Leakage Current (High Impedance)	–	-10	–	10	μ A	
GENERAL NOTES: Test Conditions unless otherwise stated: VDD = +3.3 \pm 0.3 VDC; TA = 0°C to 70°C; external load = 50 pF						

Table 12. CX20452 VC Analog Electrical Characteristics

Signal Name	Type	Characteristic	Value
M_LINE_IN, M_MIC_IN	I (DA)	Input Impedance	> 70 k Ω
		AC Input Voltage Range	1.1 VP-P
		Reference Voltage	+1.35 VDC
M_LINE_OUTP	O (DD)	Minimum Load	300 Ω
		Maximum Capacitive Load	0 μ F
		Output Impedance	10 Ω
		AC Output Voltage Range	1.4 VP-P (with reference to ground and a 600 Ω load)
		Reference Voltage	+1.35 VDC
		DC Offset Voltage	\pm 200 mV
M_SPKR_OUT	O (DF)	Minimum Load	300 Ω
		Maximum Capacitive Load	0.01 μ F
		Output Impedance	10 Ω
		AC Output Voltage Range	1.4 VP-P
		Reference Voltage	+1.35 VDC
		DC Offset Voltage	\pm 20 mV

GENERAL NOTES: Test Conditions unless otherwise stated: VDD = +3.3 \pm 0.3 VDC; MAVDD = +3.3 \pm 0.3 VDC, TA = 0°C to 70°C

Parameter	Minimum	Typical	Maximum	Units
DAC to Line Driver output (600 Ω load, 3 dB in SCF and CTF) SNR/SDR at: 4 Vp-p differential 2 Vp-p differential -10 dBm differential		88/85 82/95 72/100		dB
DAC to Speaker Driver output (150 Ω load, 3dB in SCF and CTF, -6dB in speaker driver) SNR/SDR at: 2 Vp-p 1 Vp-p -10 dBm		88/75 82/80 72/83		dB
Line Input to ADC (6 dB in AAF) SNR/SDR at -10 dBm		80/95		dB
Input Leakage Current (analog inputs)	-10		10	μ A
Output Leakage Current (analog outputs)	-10		10	μ A

3.3 Electrical and Environmental Specifications

3.3.1 Operating Conditions, Absolute Maximum Ratings, and Power Requirements

The operating conditions are specified in [Table 13](#).

The absolute maximum ratings are listed in [Table 14](#).

The current and power requirements are listed in [Table 15](#).

Table 13. Operating Conditions

Parameter	Symbol	Limits	Units
Supply Voltage	VDD	+3.0 to +3.6	VDC
Operating Ambient Temperature	TA	0 to +70	°C

Table 14. Absolute Maximum Ratings

Parameter	Symbol	Limits	Units
Supply Voltage	VDD	-0.5 to +4.0	VDC
Input Voltage	VIN	-0.5 to (VGG +0.5) ⁽¹⁾	VDC
Storage Temperature Range	TSTG	-55 to +125	°C
Analog Inputs	VIN	-0.3 to (VAA + 0.5)	VDC
Voltage Applied to Outputs in High Impedance (Off) State	VHZ	-0.5 to (VGG +0.5) ⁽¹⁾	VDC
DC Input Clamp Current	I _{IK}	±20	mA
DC Output Clamp Current	I _{OK}	±20	mA
Static Discharge Voltage (25°C)	VESD	±2500	VDC
Latch-up Current (25°C)	I _{TRIG}	±400	mA
FOOTNOTES:			
⁽¹⁾ VGG = +3.3 V ± 0.3 V or +5 V ± 5%.			

Table 15. Current and Power Requirements

Mode	Typical Current (I _{typ}) (mA)	Maximum Current (I _{max}) (mA)	Typical Power (P _{typ}) (mW)	Maximum Power (P _{max}) (mW)	Notes
CX06833					
Normal Mode: Off-hook, normal data connection	58	64	191	230	f = 28.224 MHz
Normal Mode: On-hook, idle, waiting for ring	58	64	191	230	f = 28.224 MHz
Sleep Mode	16	17.6	52.8	63.4	f = 0 MHz
CX20452 VC (Optional)					
Normal Mode	1.5	2	5	7	
GENERAL NOTES: 1. Operating voltage: VDD = +3.3 V ± 0.3 V. 2. Test conditions: VDD = +3.3 V for typical values; VDD = +3.6 V for maximum values. 3. Input Ripple ≤ 0.1 V _{peak-peak} . 4. f = Internal frequency. 5. Maximum current computed from I _{typ} : I _{max} = I _{typ} * 1.1. 6. Typical power (P _{typ}) computed from I _{typ} : P _{typ} = I _{typ} * 3.3V; Maximum power (P _{max}) computed from I _{max} : P _{max} = I _{max} * 3.6 V.					

3.3.1.1 Handling CMOS Devices

The device contains circuitry to protect the inputs against damage due to high static voltages. However, it is advised that normal precautions be taken to avoid application of any voltage higher than maximum rated voltage.

An unterminated input can acquire unpredictable voltages through coupling with stray capacitance and internal cross talk. Both power dissipation and device noise immunity degrades. Therefore, all inputs should be connected to an appropriate supply voltage.

Input signals should never exceed the voltage range from -0.5V to VGG + 0.5V. This prevents forward biasing the input protection diodes and possibly entering a latch up mode due to high current transients.

3.4 Interface and Timing Waveforms

3.4.1 External Memory Bus Timing

The external memory bus timing is listed in [Table 16](#) and illustrated in [Figure 10](#).

Table 16. Timing - External Memory Bus

Symbol	Parameter	Minimum	Typical	Maximum	Units
tFI	Internal Operating Frequency	28.224			MHz
tCYC	Internal Operating Clock Cycle	35.43			ns
Read					
tAS	READ# High to Address Valid	–	11.2	12.5	ns
tES	READ# High to ES Valid	–	12.2	13.5	ns
tRW	READ# Pulse Width	17.72		124.01	ns
tRDS	Read Data Valid to READ# High	6.1		–	ns
tRDH	READ# High to Read Data Hold	0		–	ns
Write					
tAS	WRITE# High to Address Valid	–	11.2	12.5	ns
tES	WRITE# High to ES Valid	–	12.2	13.5	ns
tWW	WRITE# to WRITE# Pulse Width	17.72		124.01	ns
tWTD	WRITE# Low to Write Data Valid	–	7.1	8.0	ns
tWTH	WRITE# High to Write Data Hold	5.0		–	ns
GENERAL NOTES:					
1. ES = RAMSEL# or ROMSEL#.					
2. Read pulse width and write pulse width: RAM: $t_{RW}, t_{WW} = 0.5 t_{CYC} = 17.72$ for Non-Extended Cycle Timing ROM: $t_{RW}, t_{WW} = 3.5 t_{CYC} = 124.01$ for Extended Cycle Timing					
3. Memory speed determination: RAM: $t_{ACCESS} = t_{CYC} - t_{ES} - t_{RDS} = 35.43 - 13.5 - 6.3 = 15.63$ ns (i.e., use 15 ns memory) ROM: $t_{ACCESS} = 4(t_{CYC}) - t_{ES} - t_{RDS} = 4(35.43) - 13.5 - 6.3 = 121.92$ ns (i.e., use 90 ns memory).					
4. Output Enable to Output Delay Timing: RAM: $t_{OE} = t_{RW} - t_{RDS} = 0.5(t_{CYC}) - t_{RDS} = 17.72 - 6.3 = 11.42$ ns ROM: $t_{OE} = t_{RW} - t_{RDS} = 3.5(t_{CYC}) - t_{RDS} = 124.01 - 6.3 = 117.71$ ns.					

Figure 10. Waveforms - External Memory Bus

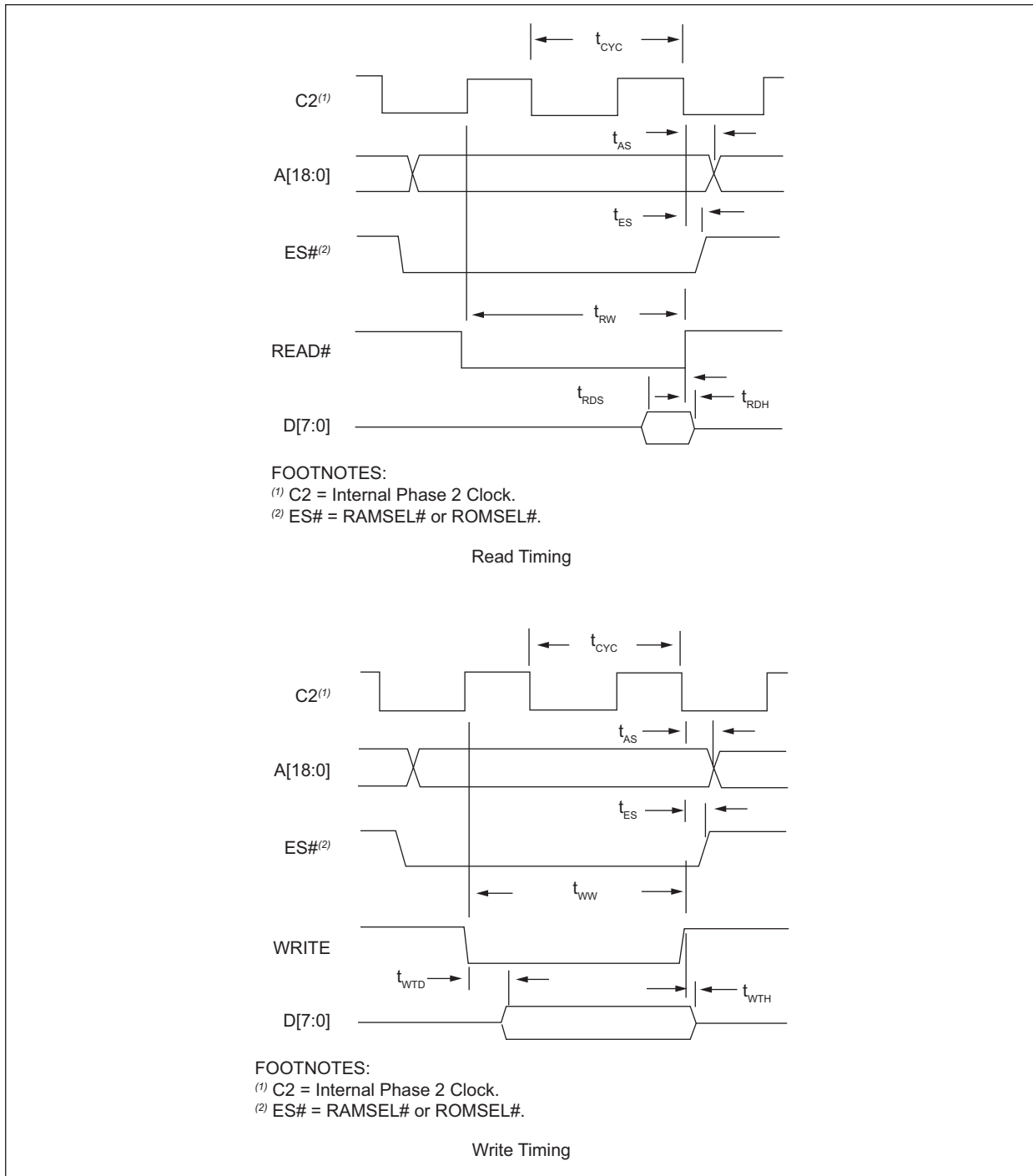

3.4.2 Parallel Host Bus Timing

The parallel host bus timing is listed in [Table 17](#) and illustrated in [Figure 11](#).

Table 17. Timing - Parallel Host Bus

Symbol	Parameter	Minimum	Maximum	Units
Read (See GENERAL NOTES 1, 2, 3, 4, 5, and 6)				
tAS	Address Setup	5	–	ns
tAH	Address Hold	10	–	ns
tCS	Chip Select Setup	0	–	ns
tCH	Chip Select Hold	10	–	ns
tRD	HRD# Strobe Width	51	–	ns
tDD	Read Data Delay	–	45	ns
tDRH	Read Data Hold	10	–	ns
Write (See GENERAL NOTES 1, 2, 3, 4, 5, and 6)				
tAS	Address Setup	5	–	ns
tAH	Address Hold	10	–	ns
tCS	Chip Select Setup	0	–	ns
tCH	Chip Select Hold	10	–	ns
tWT	HWT# Strobe Width	50	–	ns
tDS	Write Data Setup (see Note 4)	–	35	ns
tDWH	Write Data Hold (see Note 5)	5	–	ns
GENERAL NOTES:				
<ol style="list-style-type: none"> When the host executes consecutive Rx FIFO reads, a minimum delay of 2 times the internal CPU clock cycle plus 15 ns (85.86 ns at 28.224 MHz) is required from the falling edge of HRD# to the falling edge of the next Host Rx FIFO HRD# clock. When the Host executes consecutive Tx FIFO writes, a minimum delay of 2 times the internal CPU clock cycle plus 15 ns (85.86 ns at 28.224 MHz) is required from the falling edge of HWT# to the falling edge of the next Host Tx FIFO HWT# clock. $t_{RD}, t_{WT} = t_{CYC} + 15 \text{ ns}$. t_{DS} is measured from the point at which both HCS# and HWT# are active. t_{DWH} is measured from the point at which either HCS# and HWT# become inactive. Clock frequency = 28.224 MHz clock. 				

Figure 11. Waveforms - Parallel Host Bus

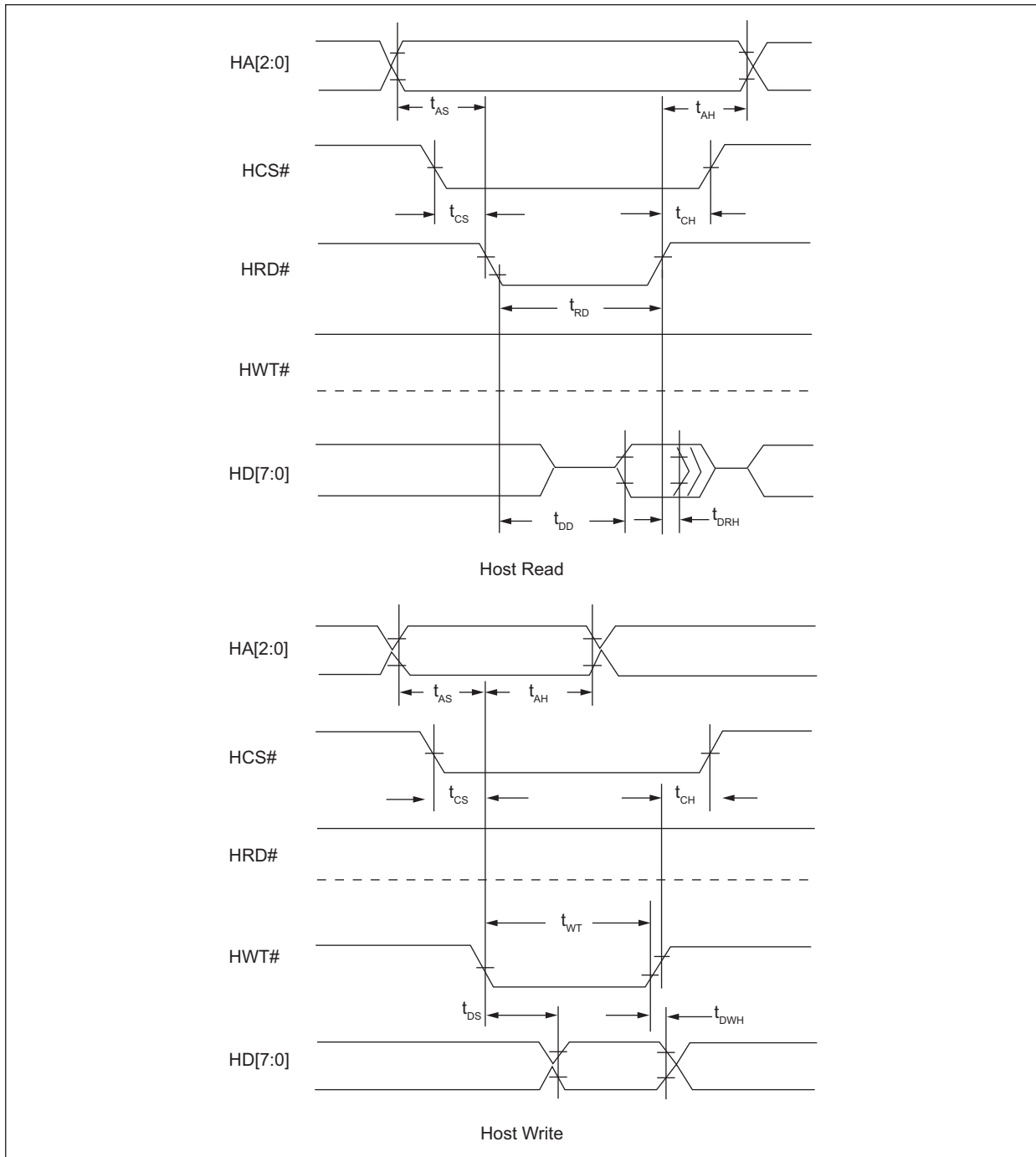

3.4.3 Serial DTE Interface

The serial DTE interface waveforms for 4800 and 9600 bps are illustrated in [Figure 12](#).

Figure 12. Waveforms - Serial DTE Interface

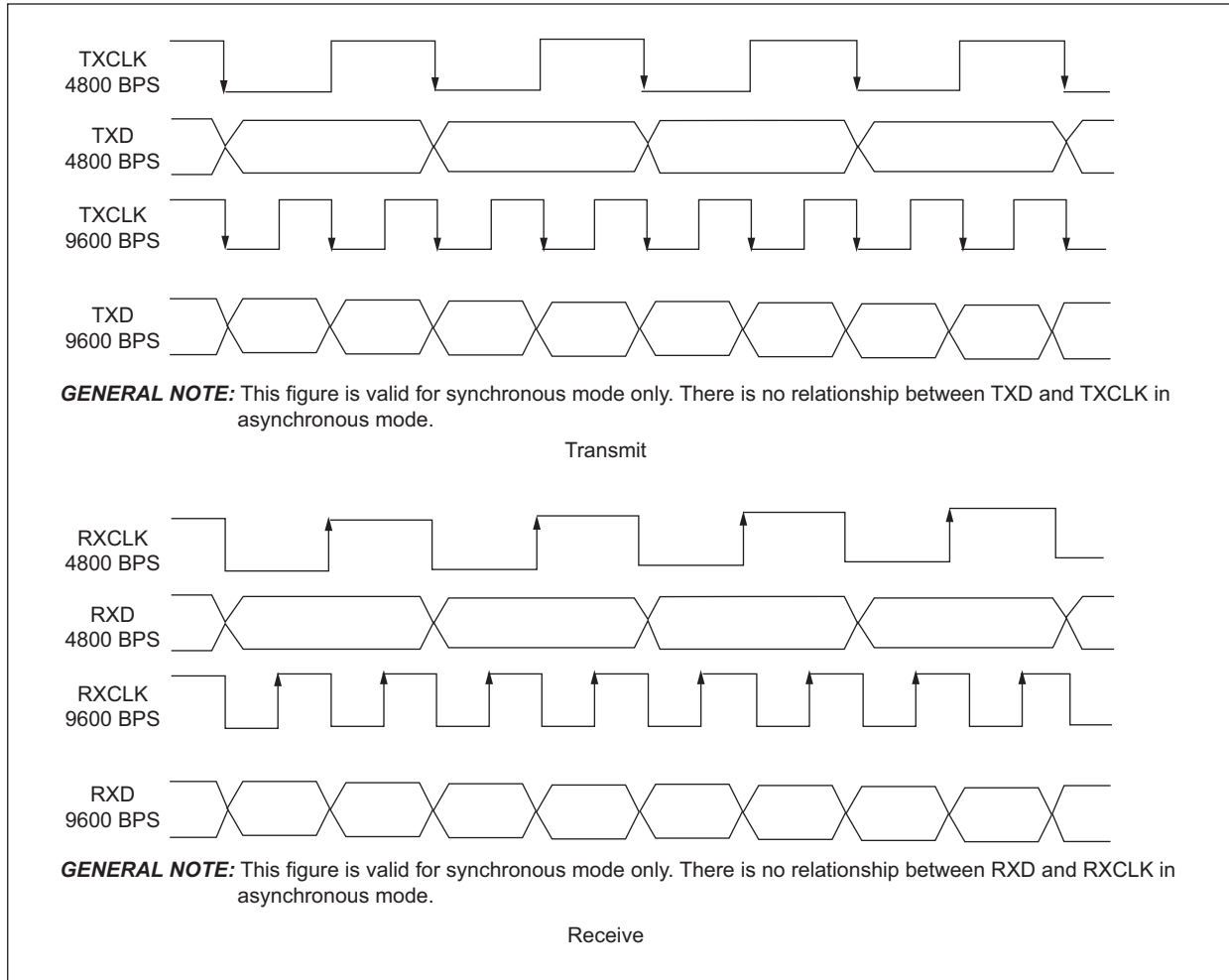

3.5 Crystal Specifications

Crystal specifications are listed in [Table 18](#).

Table 18. Crystal Specifications

Characteristic	Value
Frequency	28.224 MHz nominal
Calibration tolerance including effects due to temperature and aging	± 100 ppm at 25°C (CL = 16.5 and 19.5 pF)
Oscillation mode	Fundamental
Calibration mode	Parallel resonant
Load capacitance, C_L	18 pF nom.
Shunt Capacitance, C_O	7 pF max.
Series resistance, R_1	35-60 Ω max. @20 nW drive level
Drive level	100 μ W correlation; 500 μ W max.
Operating temperature	0°C to 70°C
Storage temperature	-40°C to 85°C

Package Dimensions

The 144-pin TQFP package dimensions are shown in [Figure 13](#).
 The 24-pin QFN package dimensions are shown in [Figure 14](#).

Figure 13. Package Dimensions - 144-Pin TQFP

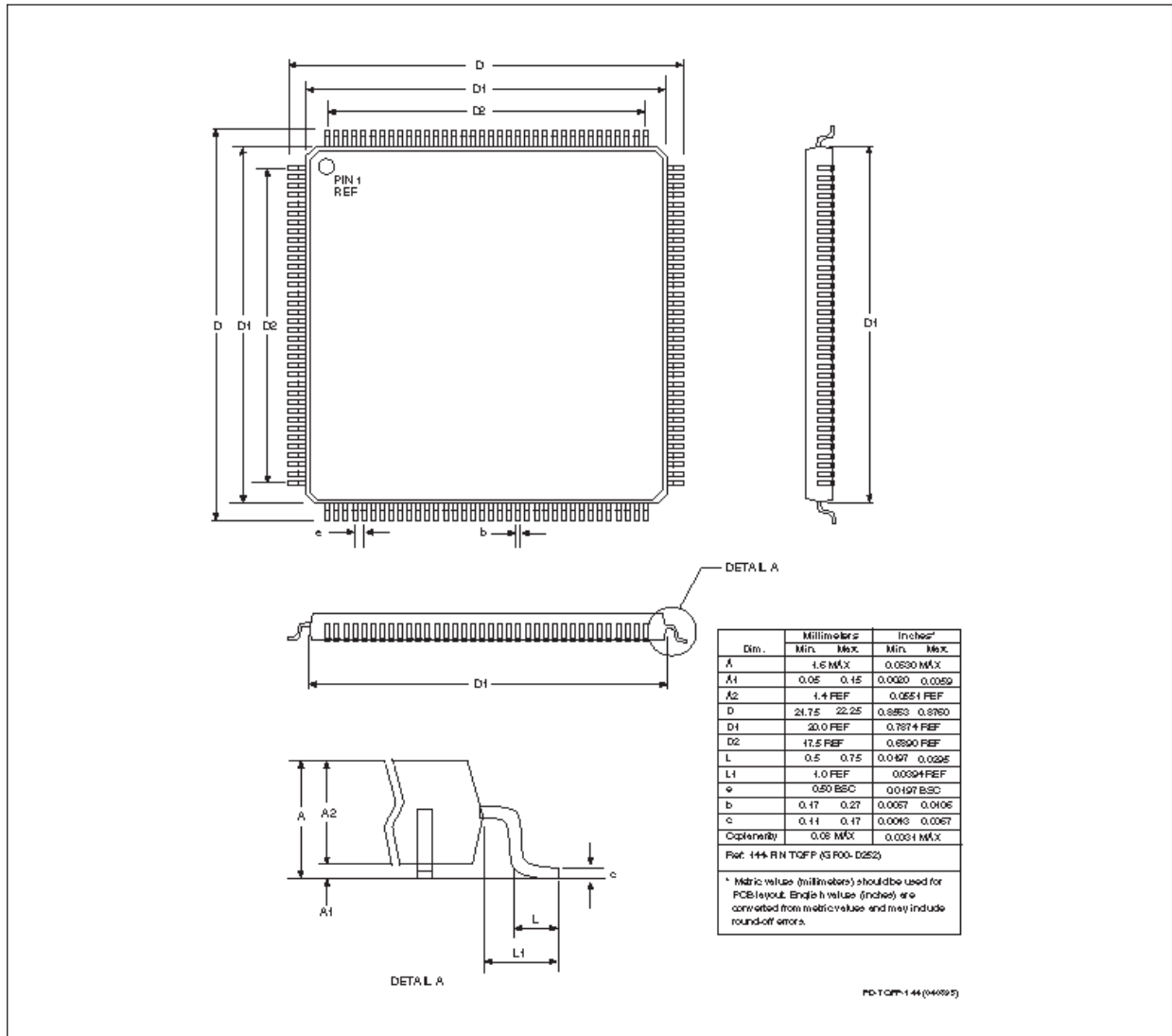
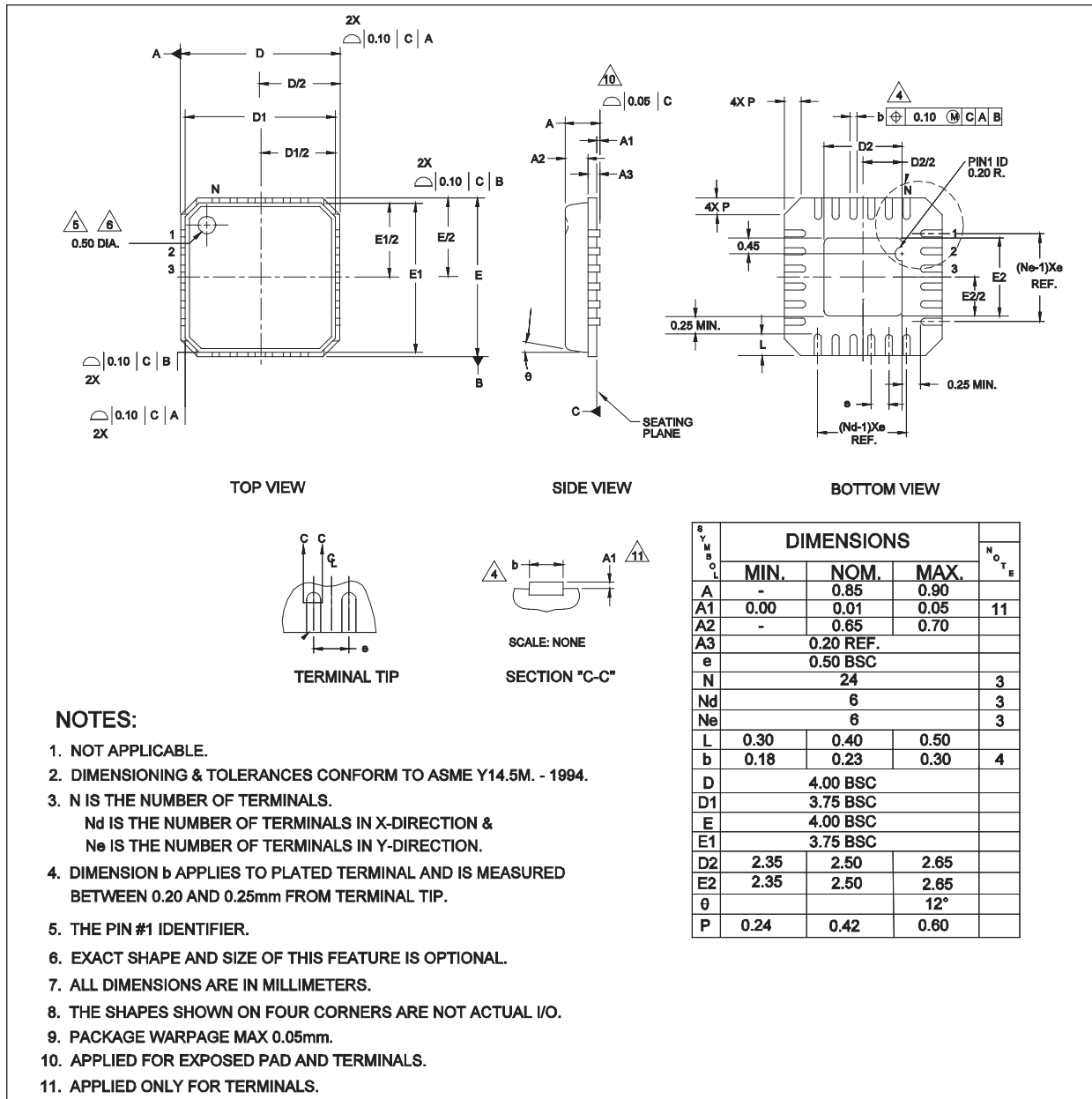

Figure 14. Package Dimensions - 24-Pin QFN



Parallel Host Interface

The modem supports a 16550A interface in parallel interface versions. The 16550A interface can operate in FIFO mode or non-FIFO mode. Non-FIFO mode is the same as 16450 interface operation. FIFO mode unique operations are identified.

5.1 Overview

The parallel interface registers and the corresponding bit assignments are shown in [Table 19](#).

Table 19. Parallel Interface Registers (1 of 2)

Register Number	Register Name	Bit Number							
		7	6	5	4	3	2	1	0
7	Scratch Register (SCR)	Scratch Register							
6	Modem Status Register (MSR)	Data Carrier Detect (DCD)	Ring Indicator (RI)	Data Set Ready (DSR)	Clear to Send (CTS)	Delta Data Carrier Detect (DDCD)	Trailing Edge of Ring Indicator (TERI)	Delta Data Set Ready (DDSR)	Delta Clear to Send (DCTS)
5	Line Status Register (LSR)	RX FIFO Error	Transmitter Empty (TEMT)	Transmitter Buffer Register Empty (THRE)	Break Interrupt (BI)	Framing Error (FE)	Parity Error (PE)	Overrun Error (OE)	Receiver Data Ready (DR)
4	Modem Control Register (MCR)	0	0	0	Local Loopback	Out 2	Out 1	Request to Send (RTS)	Data Terminal Ready (DTR)
3	Line Control Register (LCR)	Divisor Latch Access Bit (DLAB)	Set Break	Stick Parity	Even Parity Select (EPS)	Parity Enable (PEN)	Number of Stop Bits (STB)	Word Length Select Bit 1 (WLS1)	Word Length Select Bit 0 (WLS0)
2	Interrupt Identify Register (IIR) (Read Only)	FIFOs Enabled	FIFOs Enabled	0	0	Pending Interrupt ID Bit 2	Pending Interrupt ID Bit 1	Pending Interrupt ID Bit 0	"0" if Interrupt Pending
2	FIFO Control Register (FCR) (Write Only)	Receiver Trigger MSB	Receiver Trigger LSB	Reserved	Reserved	DMA Mode Select	TX FIFO Reset	RX FIFO Reset	FIFO Enable

Table 19. Parallel Interface Registers (2 of 2)

Register Number	Register Name	Bit Number							
		7	6	5	4	3	2	1	0
1 (DLAB = 0)	Interrupt Enable Register (IER)	0	0	0	0	Enable Modem Status Interrupt (EDSSI)	Enable Receiver Line Status Interrupt (ELSI)	Enable Transmitter Holding Register Empty Interrupt (ETBEI)	Enable Received Data Available Interrupt (ERBFI)
0 (DLAB = 0)	Transmitter Buffer Register (THR)	Transmitter FIFO Buffer Register (Write Only)							
0 (DLAB = 0)	Receiver Buffer Register (RBR)	Receiver FIFO Buffer Register (Read Only)							
1 (DLAB = 1)	Divisor Latch MSB Register (DLM)	Divisor Latch MSB							
0 (DLAB = 1)	Divisor Latch LSB Register (DLL)	Divisor Latch LSB							

The modem emulates the 16450/16550A interface and includes both a 16-byte receiver data first-in first-out buffer (RX FIFO) and a 16-byte transmit data first-in first-out buffer (TX FIFO). When FIFO mode is selected in the FIFO Control Register (FCR0 = 1), both FIFOs are operative. Furthermore, when FIFO mode is selected, DMA operation of the FIFO can also be selected (FCR3 = 1). When FIFO mode is not selected, operation is restricted to 16450 interface operation.

The received data is read by the host from the Receiver Buffer (RX Buffer). The RX Buffer corresponds to the Receiver Buffer Register in a 16550A device. In FIFO mode, the RX FIFO operates transparently behind the RX Buffer. Interface operation is described with reference to the RX Buffer in both FIFO and non-FIFO modes.

The transmit data is loaded by the host into the Transmit Buffer (TX Buffer). The TX Buffer corresponds to the Transmit Holding Register in a 16550A device. In FIFO mode, the TX FIFO operates transparently behind the TX Buffer. Interface operation is described with reference to the TX Buffer in both FIFO and non-FIFO modes.

5.2 Register Signal Definitions

5.2.1 IER - Interrupt Enable Register (Addr = 1, DLAB = 0)

The IER enables five types of interrupts that can separately assert the HINT output signal (Table 20). A selected interrupt can be enabled by setting the corresponding enable bit to a 1, or disabled by setting the corresponding enable bit to a 0. Disabling an interrupt in the IER prohibits setting the corresponding indication in the IIR and assertion of HINT. Disabling all interrupts (resetting IER0 - IER3 to a 0) inhibits setting of any Interrupt Identifier Register (IIR) bits and inhibits assertion of the HINT output. All other system functions operate normally, including the setting of the Line Status Register (LSR) and the Modem Status Register (MSR).

Bits 7-4 Not used.

Always 0.

Bit 3 Enable Modem Status Interrupt (EDSSI).

This bit, when a 1, enables assertion of the HINT output whenever the Delta CTS (MSR0), Delta DSR (MSR1), Delta TER (MSR2), or Delta DCD (MSR3) bit in the Modem Status Register (MSR) is a 1. This bit, when a 0, disables assertion of HINT due to setting of any of these four MSR bits.

Bit 2 Enable Receiver Line Status Interrupt (ELSI).

This bit, when a 1, enables assertion of the HINT output whenever the Overrun Error (LSR1), Parity Error (LSR2), Framing Error (LSR3), or Break Interrupt (LSR4) receiver status bit in the Line Status Register (LSR) changes state. This bit, when a 0, disables assertion of HINT due to change of the receiver LSR bits 1-4.

Bit 1 Enable Transmitter Holding Register Empty Interrupt (ETBEI).

This bit, when a 1, enables assertion of the HINT output when the Transmitter Empty bit in the Line Status Register (LSR5) is a 1. This bit, when a 0, disables assertion of HINT due to LSR5.

Bit 0 Enable Receiver Data Available Interrupt (ERBFI) and Character Time-out in FIFO Mode.

This bit, when a 1, enables assertion of the HINT output when the Receiver Data Ready bit in the Line Status Register (LSR0) is a 1 or character time-out occurs in the FIFO mode. This bit, when a 0, disables assertion of HINT due to the LSR0 or character time-out.

5.2.2 FCR - FIFO Control Register (Addr = 2, Write Only)

The FCR is a write-only register used to enable FIFO mode, clear the RX FIFO and TX FIFO, enable DMA mode, and set the RX FIFO trigger level.

Bits 7-6 RX FIFO Trigger Level.

FCR7 and FCR6 set the trigger level for the RX FIFO (Receiver Data Available) interrupt.

FCR7	FCR6	RX FIFO Trigger Level (Bytes)
0	0	01
0	1	04
1	0	08
1	1	14

Bits 5-4 Not used.

Bit 3 DMA Mode Select.

When FIFO mode is selected (FCR0 = 1), FCR3 selects non-DMA operation (FCR3 = 0) or DMA operation (FCR3 = 1). When FIFO mode is not selected (FCR0 = 0), this bit is not used (the modem operates in non-DMA mode in 16450 operation).

DMA operation in FIFO mode

RXRDY will be asserted when the number of characters in the RX FIFO is equal to or greater than the value in the RX FIFO Trigger Level (IIR0-IIR3 = 4h) or the received character time-out (IIR0-IIR3 = Ch) has occurred. RXRDY will go inactive when there are no more characters in the RX FIFO.

TXRDY will be asserted when there are one or more empty (unfilled) locations in the TX FIFO. TXRDY will go inactive when the TX FIFO is completely full.

Non-DMA operation in FIFO mode

RXRDY will be asserted when there are one or more characters in the RX FIFO. RXRDY will go inactive when there are no more characters in the RX FIFO.

TXRDY will be asserted when there are no characters in the TX FIFO. TXRDY will go inactive when the first character is loaded into the TX FIFO Buffer.

Bit 2 TX FIFO Reset.

When FCR2 is a 1, all bytes in the TX FIFO are cleared. This bit is cleared automatically by the modem.

Bit 1 RX FIFO Reset.

When FCR1 is a 1, all bytes in the RX FIFO are cleared. This bit is cleared automatically by the modem.

Bit 0 FIFO Enable.

When FCR0 is a 0, 16450 mode is selected and all bits are cleared in both FIFOs. When FCR0 is a 1, FIFO mode (16550A mode) is selected and both FIFOs are enabled. FCR0 must be a 1 when other bits in the FCR are written or they will not be acted upon.

5.2.3 IIR - Interrupt Identifier Register (Addr = 2)

The Interrupt Identifier Register (IIR) identifies the existence and type of up to five prioritized pending interrupts. Four priority levels are set to assist interrupt processing in the host. The four levels, in order of decreasing priority, are: Highest: Receiver Line Status, 2: Receiver Data Available or Receiver Character Time-out, 3: TX Buffer Empty, and 4: Modem Status.

When the IIR is accessed, the modem freezes all interrupts and indicates the highest priority interrupt pending to the host. Any change occurring in interrupt conditions are not indicated until this access is complete.

Bits 7-6 FIFO Mode.

These two bits copy FCR0.

Bits 5-4 Not Used.

Always 0.

Bits 3-1 Highest Priority Pending Interrupt.

These three bits identify the highest priority pending interrupt ([Table 20](#)). Bit 3 is applicable only when FIFO mode is selected, otherwise bit 3 is a 0.

Bit 0 Interrupt Pending.

When this bit is a 0, an interrupt is pending; IIR bits 1-3 can be used to determine the source of the interrupt. When this bit is a 1, an interrupt is not pending.

Table 20. Interrupt Sources and Reset Control

Interrupt Identification Register					Interrupt Set and Reset Functions		
Bit 31	Bit 2	Bit 1	Bit 0	Priority Level	Interrupt Type	Interrupt Source	Interrupt Reset Control
0	0	0	1	—	None	None	—
0	1	1	0	Highest	Receiver Line Status	Overrun Error OE (LSR1), Parity Error (PE) (LSR2), Framing Error (FE) (LSR3), or Break Interrupt (BI) (LSR4)	Reading the LSR
0	1	0	0	2	Received Data Available	Received Data Available (LSR0) or RX FIFO Trigger Level (FCR6-FCR7) Reached ⁽¹⁾	Reading the RX Buffer or the RX FIFO drops below the Trigger Level
1	1	0	0	2	Character Time-out Indication 1	The RX FIFO contains at least 1 character and no characters have been removed from or input to the RX FIFO during the last 4 character times.	Reading the RX Buffer
0	0	1	0	3	TX Buffer Empty	TX Buffer Empty	Reading the IIR or writing to the TX Buffer
0	0	0	0	4	Modem Status	Delta CTS (DCTS) (MSR0), Delta DSR (DDSR) (MSR1), Trailing Edge Ring Indicator (TERI) (MSR3), or Delta DCD (DCD) (MSR4)	Reading the MSR
FOOTNOTES:							
⁽¹⁾ FIFO Mode only.							

5.2.4 LCR - Line Control Register (Addr = 3)

The Line Control Register (LCR) specifies the format of the asynchronous data communications exchange.

- Bit 7** Divisor Latch Access Bit (DLAB).
This bit must be set to a 1 to access the Divisor latch registers during a read or write operation. It must be reset to a 0 to access the Receiver Buffer, the Transmitter Buffer, or the Interrupt Enable Register.
- Bit 6** Set Break.
When bit 6 is a 1, the transmit data is forced to the break condition, i.e., space (0) is sent. When bit 6 is a 0, break is not sent. The Set Break bit acts only on the transmit data and has no effect on the serial in logic.
- Bit 5** Stick Parity.
When parity is enabled (LCR3 = 1) and stick parity is selected (LCR5 = 1), the parity bit is transmitted and checked by the receiver as a 0 if even parity is selected (LCR4 = 1) or as a 1 if odd parity is selected (LCR4 = 0). When stick parity is not selected (LCR3 = 0), parity is transmit and checked as determined by the LCR3 and LCR4 bits.
- Bit 4** Even Parity Select (EPS).
When parity is enabled (LCR3 = 1) and stick parity is not selected (LCR5 = 0), the number of 1s transmitted or checked by the receiver in the data word bits and parity bit is either even (LCR4 = 1) or odd (LCR4 = 0).
- Bit 3** Enable Parity (PEN).
When bit 3 is a 1, a parity bit is generated in the serial out (transmit) data stream and checked in the serial in (receive) data stream as determined by the LCR 4 and LCR5 bits. The parity bit is located between the last data bit and the first stop bit.
- Bit 2** Number of Stop Bits (STB).
This bit specifies the number of stop bits in each serial out character. If bit 2 is a 0, one stop bit is generated regardless of word length. If bit 2 is a 1 and 5-bit word length is selected, one and one-half stop bits are generated. If bit 2 is a 1 and a 6-, 7-, or 8-bit word length is selected, two stop bits are generated. The serial in logic checks the first stop bit only, regardless of the number of stop bits selected.
- Bits 1-0** Word Length Select (WLS0 and WLS1).
These two bits specify the number of bits in each serial in or serial out character. The encoding of bits 0 and 1 is:

Bit 1	Bit 0	Word Length
0	0	5 Bits (Not supported)
0	1	6 Bits (Not supported)
1	0	7 Bits
1	1	8 Bits

5.2.5 MCR - Modem Control Register (Addr = 4)

The Modem Control Register (MCR) controls the interface with the modem or data set.

Bit 7-5 Not used.

Always 0.

Bit 4 Local Loopback.

When this bit is set to a 1, the diagnostic mode is selected and the following occurs:

1. Data written to the Transmit Buffer is looped back to the Receiver Buffer.
2. The DTS (MCR0), RTS (MCR1), Out1 (MCR2), and Out2 (MCR3) modem control register bits are internally connected to the DSR (MSR5), CTS (MSR4), RI (MSR6), and DCD (MSR7) modem status register bits, respectively.

Bit 3 Output 2.

When this bit is a 1, HINT is enabled. When this bit is a 0, HINT is in the high impedance state.

Bit 2 Output 1.

This bit is used in local loopback (see MCR4).

Bit 1 Request to Send (RTS).

This bit controls the Request to Send (RTS) function. When this bit is a 1, RTS is on. When this bit is a 0, RTS is off.

Bit 0 Data Terminal Ready (DTR).

This bit controls the Data Terminal Ready (DTR) function. When this bit is a 1, DTR is on. When this bit is a 0, DTR is off.

5.2.6 LSR - Line Status Register (Addr = 5)

This 8-bit register provides status information to the host concerning data transfer.

Bit 7 RX FIFO Error.

In the 16450 mode, this bit is not used and is always 0.

In the FIFO mode, this bit is set if there are one or more characters in the RX FIFO with a parity error, framing error, or break indication detected. This bit is reset to a 0 when the host reads the LSR and none of the above conditions exist in the RX FIFO.

Bit 6 Transmitter Empty (TEMT).

This bit is set to a 1 whenever the TX Buffer (THR) and equivalent of the Transmitter Shift Register (TSR) are both empty. It is reset to a 0 whenever either the THR or the equivalent of the TSR contains a character.

In the FIFO mode, this bit is set to a 1 when ever the TX FIFO and the equivalent of the TSR are both empty.

Bit 5 Transmitter Holding Register Empty (THRE) [TX Buffer Empty].

This bit, when set, indicates that the TX Buffer is empty and the modem can accept a new character for transmission. In addition, this bit causes the modem to issue an interrupt to the host when the Transmit Holding Register Empty Interrupt Enable bit (IIR1) is set to 1. The THRE bit is set to a 1 when a character is transferred from the TX Buffer. The bit is reset to 0 when a byte is written into the TX Buffer by the host.

In the FIFO mode, this bit is set when the TX FIFO is empty; it is cleared when at least one byte is in the TX FIFO.

Bit 4 Break Interrupt (BI).

This bit is set to a 1 whenever the received data input is a space (logic 0) for longer than two full word lengths plus 3 bits. The BI bit is reset when the host reads the LSR.

Bit 3 Framing Error (FE).

This bit indicates that the received character did not have a valid stop bit. The FE bit is set to a 1 whenever the stop bit following the last data bit or parity bit is detected as a logic 0 (space). The FE bit is reset to a 0 when the host reads the LSR.

In the FIFO mode, the error indication is associated with the particular character in the FIFO it applies to; the FE bit is set to a 1 when this character is loaded into the RX Buffer.

Bit 2 Parity Error (PE).

This bit indicates that the received data character in the RX Buffer does not have the correct even or odd parity, as selected by the Even Parity Select bit (LCR4) and the Stick Parity bit (LCR5). The PE bit is reset to a 0 when the host reads the LSR.

In the FIFO mode, the error indication is associated with the particular character in the it applies to; the PE bit is set to a 1 when this character is loaded into the RX Buffer.

- Bit 1** **Overrun Error (OE).**
 This bit is set to a 1 whenever received data is loaded into the RX Buffer before the host has read the previous data from the RX Buffer. The OE bit is reset to a 0 when the host reads the LSR.
 In the FIFO mode, if data continues to fill beyond the trigger level, an overrun condition will occur only if the RX FIFO is full and the next character has been completely received.
- Bit 0** **Receiver Data Ready (DR).**
 This bit is set to a 1 whenever a complete incoming character has been received and has been transferred into the RX Buffer. The DR bit is reset to a 0 when the host reads the RX Buffer.
 In the FIFO mode, the DR bit is set when the number of received data bytes in the RX FIFO equals or exceeds the trigger level specified in FCR0-FCR1.

5.2.7 **MSR - Modem Status Register (Addr = 6)**

The Modem Status Register (MSR) reports current state and change information of the modem. Bits 4-7 supply current state and bits 0-3 supply change information. The change bits are set to a 1 whenever a control input from the modem changes state from the last MSR read by the host. Bits 0-3 are reset to 0 when the host reads the MSR or upon reset.

Whenever bits 0, 1, 2, or 3 are set to a 1, a Modem Status Interrupt (IIR0-IIR3 = 0) is generated.

- Bit 7** **Data Carrier Detect (DCD).**
 This bit indicates the logic state of the DCD# (RLSD#) output. If Loopback is selected (MCR4 = 1), this bit reflects the state of the Out2 bit in the MCR (MCR3).
- Bit 6** **Ring Indicator (RI).**
 This bit indicates the logic state of the RI# output. If Loopback is selected (MCR4 = 1), this bit reflects the state of the Out1 bit in the MCR (MCR2).
- Bit 5** **Data Set Ready (DSR).**
 This bit indicates the logic state of the DSR# output. If Loopback is selected (MCR4 = 1), this bit reflects the state of the DTR bit in the MCR (MCR0).
- Bit 4** **Clear to Send (CTS).**
 This bit indicates the logic state of the CTS# output. If Loopback is selected (MCR4 = 1), this bit reflects the state of the RTS bit in the MCR (MCR1).
- Bit 3** **Delta Data Carrier Detect (DDCD).**
 This bit is set to a 1 when the DCD bit changes state since the MSR was last read by the host.
- Bit 2** **Trailing Edge of Ring Indicator (TERI).**
 This bit is set to a 1 when the RI bit changes from a 1 to a 0 state since the MSR was last read by the host.
- Bit 1** **Delta Data Set Ready (DDSR).**
 This bit is set to a 1 when the DSR bit has changed since the MSR was last read by the host.
- Bit 0** **Delta Clear to Send (DCTS).**
 This bit is set to a 1 when the CTS bit has changed since the MSR was last read by the host.

5.2.8 RBR - RX Buffer (Receiver Buffer Register) (Addr = 0, DLAB = 0)

The RX Buffer (RBR) is a read-only register at location 0 (with DLAB = 0). Bit 0 is the least significant bit of the data, and is the first bit received.

5.2.9 THR - TX Buffer (Transmitter Holding Register) (Addr = 0, DLAB = 0)

The TX Buffer (THR) is a write-only register at address 0 when DLAB = 0. Bit 0 is the least significant bit and the first bit sent.

5.2.10 Divisor Registers (Addr = 0 and 1, DLAB = 1)

The Divisor Latch LS (least significant byte) and Divisor Latch MS (most significant byte) are two read-write registers at locations 0 and 1 when DLAB = 1, respectively.

The baud rate is selected by loading each divisor latch with the appropriate hex value.

Programmable values corresponding to the desired baud rate are listed in [Table 21](#).

Table 21. Programmable Baud Rates

Divisor Latch (Hex)			
MS	LS	Divisor (Decimal)	Baud Rate
06	00	1536	75
04	17	1047	110
03	00	768	150
01	80	384	300
00	C0	192	600
00	60	96	1200
00	30	48	2400
00	18	24	4800
00	0C	12	9600
00	06	6	19200
00	04	4	28800
00	03	3	38400
00	02	2	57600
00	01	1	115200
00	00	NA	230400

5.2.11 SCR - Scratch Register (Addr = 7)

The Scratchpad Register is a read-write register at location 7. This register is not used by the modem and can be used by the host for temporary storage.

5.3 Receiver FIFO Interrupt Operation

5.3.1 Receiver Data Available Interrupt

When the FIFO mode is enabled (FCR0 = 1) and receiver interrupt (RX Data Available) is enabled (IER0 = 1), receiver interrupt operation is as follows:

1. The Receiver Data Available Flag (LSR0) is set as soon as a received data character is available in the RX FIFO. LSR0 is cleared when the RX FIFO is empty.
2. The Receiver Data Available interrupt code (IIR0-IIR4 = 4h) is set whenever the number of received data bytes in the RX FIFO reaches the trigger level specified by FCR6-FCR7 bits; it is cleared whenever the number of received data bytes in the RX FIFO drops below the trigger level specified by FCR6-FCR7 bits.
3. The HINT interrupt is asserted whenever the number of received data bytes in the RX FIFO reaches the trigger level specified by FCR6-FCR7 bits. HINT interrupt is de-asserted when the number of received data bytes in the RX FIFO drops below the trigger level specified by FCR6-FCR7 bits.

5.3.2 Receiver Character Time-out Interrupts

When the FIFO mode is enabled (FCR0 = 1) and receiver interrupt (Receiver Data Available) is enabled (IER0 = 1), receiver character time-out interrupt operation is as follows:

1. A Receiver character time-out interrupt code (IIR0-IIR3 = Ch) is set if at least one received character is in the RX FIFO, the most recent received serial character was longer than four continuous character times ago (if 2 stop bits are specified, the second stop bit is included in this time period), and the most recent host read of the RX FIFO was longer than four continuous character times ago.

5.4 Transmitter FIFO Interrupt Operation

5.4.1 Transmitter Empty Interrupt

When the FIFO mode is enabled (FCR0 = 1) and transmitter interrupt (TX Buffer Empty) is enabled (IER0 = 1), transmitter interrupt operation is as follows:

1. The TX Buffer Empty interrupt code (IIR0-IIR3 = 2h) will occur when the TX Buffer is empty; it is cleared when the TX Buffer is written to (1 to 16 characters) or the IIR is read.
2. The TX Buffer Empty indications will be delayed 1 character time minus the last stop bit time whenever the following occur: THRE = 1 and there have not been at least two bytes at the same time in the TX FIFO Buffer since the last setting of THRE was set. The first transmitter interrupt after setting FCR0 will be immediate.

www.conexant.com
General Information:
U.S. and Canada: (888) 855-4562
International: (949) 483-4600
Headquarters – Newport Beach
4000 MacArthur Blvd.
Newport Beach, CA 92660

