

M52063SP

NTSC/QUASI PAL TRANSCODER

DESCRIPTION

The M52063SP converts NTSC signals into quasi PAL signals efficiently. It has a horizontal AFC, burst gate pulse generator, gain variable amplifier and analog switch.

With a VCR having this circuit, images recorded on NTSC soft tape can be viewed with a PAL TV set with NTSC color signals being converted into quasi PAL signals.

FEATURES

- Conversion needs only a small number of external circuits.
- Conversion is carried out in steps: -45° burst signals, chroma signals, $+45^\circ$ burst signals and blanking.
- Quasi PAL signals are stable because change-over signals are generated by the horizontal AFC.
- When a PAL soft tape is set, a through mode is output being amplified by 6 dB.
- Burst gate pulse position and width can be set with external constants. The burst gate pulse can be output.
- It is only AFC free run frequency that needs adjustment.

APPLICATION

VCR

RECOMMENDED OPERATING CONDITION

Supply voltage range4.5~5.5V
 Rated supply voltage5.0V

PIN CONFIGURATION (TOP VIEW)

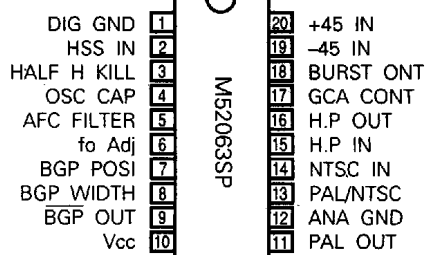

Outline 20P4B

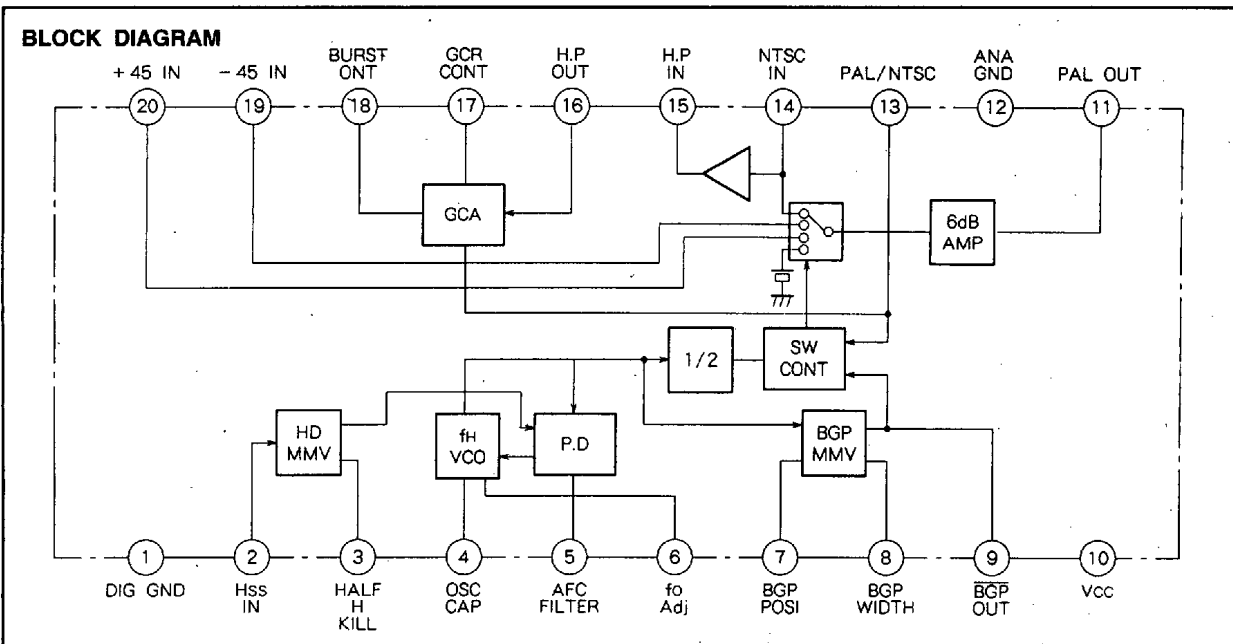

6249826 0022830 3T8



M52063SP

NTSC/QUASI PAL TRANSCODER

ABSOLUTE MAXIMUM RATINGS

Symbol	Parameter	Ratings	Unit
V _{cc}	Supply voltage	6	V
P _a	Power dissipation	1000	mW
K _θ	Thermal derating	10	mW/°C
V _{surg}	Electrostatic discharge	± 200V minimum	V
T _{opr}	Operating temperature	- 20~75	°C
T _{stg}	Storage temperature	- 40~125	°C

ELECTRICAL CHARACTERISTICS (S10 = ON, S15 = S17 = OFF S35 = 1, V13 = 0V, unless otherwise noted)

Symbol	Parameter	Test conditions	Limits			Unit
			Min.	Typ.	Max.	
I _{cc}	Circuit current	No input S10 = OFF. Measure current flowing to pin ⑩.	15	20	25	mA
G ₁₄₋₁₁	Through mode gain	Input SG1 to pin ⑭, V13 = 5V. Measure V _{P-P} of pin ⑪ to take the ratio with input. G(14 - 11) = 20 LOG $\frac{\text{Output level}}{\text{Input level}}$	4.5	5.5	6.5	dB
B ₁₉₋₁₁	- 45° gain	Input SG1 to pin ⑱. Measure V _{P-P} of pin ⑪ to take the ratio with input. G(19 - 11) = 20 LOG $\frac{\text{Output level}}{\text{Input level}}$	4.0	5.0	6.0	dB
G ₂₀₋₁₁	+ 45° gain	Input SG1 to pin ⑳. Measure V _{P-P} of pin ⑪ to take the ratio with input. G(20 - 11) = 20 LOG $\frac{\text{Output level}}{\text{Input level}}$	4.0	5.0	6.0	dB
ΔG _{45°}	+ 45° - 45° gain difference	G(19 - 11) - G(20 - 11)		0.0	0.5	dB
G ₁₄₋₁₅	H.P DRIVE gain	Input SG1 to pin ⑭. Measure V _{P-P} of pin ⑮ to take the ratio with input. G(14 - 15) = 20 LOG $\frac{\text{Output level}}{\text{Input level}}$	- 0.9	- 0.2	0.5	dB
VCO _{sw}	VCO mode switchover	Input SG2 to pin ② S15=0N. Turn V15 down from 5V, and measure V15 when the frequency of pin ⑦ waveform becomes equal to SG2.	3.2	3.5	3.8	V
G _{16-18max}	GCA MAX gain	Input SG3 to pin ⑯, S17 = ON, V17 = 5V. Measure V _{P-P} of pin ⑯ to take the ratio with input. 20 LOG $\frac{\text{Output level}}{\text{Input level}}$	6.0	7.0	8.0	dB
G _{16-18open}	GCA OPEN gain	Input SG3 to pin ⑯, S17 = OFF. Measure V _{P-P} of pin ⑯ to take the ratio with input. 20 LOG $\frac{\text{Output level}}{\text{Input level}}$	2.9	4.4	5.9	dB
G _{16-18min}	GCA MIN gain	Input SG3 to pin ⑯, S17 = ON, V17 = 0V. Measure V _{P-P} of pin ⑯ to take the ratio with input. 20 LOG $\frac{\text{Output level}}{\text{Input level}}$	- 6.5	- 5.0	- 3.5	dB
PAL1	Quasi PAL 1	Input SG4 - 1 to pins ⑭ and ⑱, and input SG4 - 2 to pin ②. Output waveform of pin ⑪ should be normal. (Note 1)				-
PAL2	Quasi PAL 2	Input SG4 - 1 to pins ⑭ and ⑱, and input SG4 - 2 to pin ②. Output waveform of pin ⑪ should be normal. (Note 2)				-
TH	GCA OFF in through	Input SG1 to pin ⑯, S13 = 5V. Ensure that the signal is not output to pin ⑱.				-
R _T	Discharge reset time	Input SG2 to pin ②. Measure discharge reset time of pin ③. (Note 2)	40	45	50	μs
HHK	Half H killer	Input SG5 to pin ②, S5=2. Increase the frequency of SG5 and measure the maximum frequency when the waveform frequency of pin ⑤ becomes equal to SG5. (HHK=1/f)	40	45	50	μs

6249826 0022831 234



ELECTRICAL CHARACTERISTICS (cont.)

Symbol	Parameter	Test conditions	Limits			Unit
			Min.	Typ.	Max.	
H.DP	H.D POSI	Input SG2 to pin ②, S5 = 2. Measure the time difference between fh rise time and pin ⑤ waveform fall time. (Note 2)	0	0.2	0.5	μs
HDW	H.D WIDTH	Input SG2 to pin ②, S5 = 2. Measure the pulse width of pin ⑤ waveform. (Note 2)	3.9	4.4	4.9	μs
HSSH	Input synchronous detection peak value	Input SG6 to pin ②. Increase the pulse height of SG6 and measure the pulse height when the frequency of pin ⑦ waveform becomes equal to SG6.	3.6		5.0	V
β	VCO β	No input, S5 = 3, S15 = ON, V15 = 5V. Change V5 to from 3V to 4V and measure the output frequency change of pin ⑦. The maximum ramp is expressed by character β.	6	9	12	Hz/mV
CLW	Capture range width	Input SG2 to pin ②. Increase or decrease the frequency from a distance and measure the frequency when the waveform of pin ⑤ is locked. (Note 2)	2.0	2.6		kHz
RLW	Lock range width	Input SG2 to pin ②. Increase and decrease the frequency, and measure it when the waveform of pin ⑤ comes out of the locked state. (Note 2)	3.0	3.7		kHz
P/N	Quasi PAL/normal switchover voltage	Input SG4-1 to pin ④. Input SG4-2 to pin ②, turn V13 down from 5V and measure the voltage when the chroma of pin ⑩ goes off at every 1H.	1.9	2.2	2.5	V
BGPP	BGP POSI	Input SG2 to pin ②. Measure the difference between fh rise time and pin ⑨ waveform fall time. (Note 2)	2.2	2.8	3.4	μs
BGPW	BGP WIDTH	Input SG2 to pin ②. Measure the pulse width of pin ⑨ waveform. (Note 2)	6.2	6.8	7.4	μs
BGPH	BGP OUT HI voltage	Input SG2 to pin ②. Measure HI voltage of pin ⑨ output waveform. (Note 2)	3.6	4.0		V
BGPL	BGP OUT LO voltage	Input SG2 to pin ②. Measure LO voltage of pin ⑨ output waveform. (Note 2)		0	0.5	V
VCCR	Operating supply voltage range	Standard application circuit operation should be normal. (Vcc voltage)	4.5	5.0	5.5	V
HsST	Input synchronous detection rise time	Input SG7 to pin ②. Lengthen rise time gradually and measure the rise time (HsST) just before the charge and discharge waveform of pin ③ disappears. (Note 2)			1.5	μs

M52063SP

NTSC/QUASI PAL TRANSCODER

INPUT SIGNAL

SG NO.	Signals (50Ω termination)
SG1	f = 4.43MHz 0.25V _{P-P} CW
SG2	f = 15.75kHz Pulse
SG3	f = 4.43MHz 50mV _{P-P} CW
SG4	1 f = 4.43MHz Chroma signal
	2 f = 15.75kHz Pulse
SG5	f = 15.75kHz Pulse (Frequency variable)
SG6	f = 15.75kHz Pulse (Peak value variable)

Note SG4 - 1 and SG4 - 2 should be synchronized.

SUPPLEMENT

1. SG2

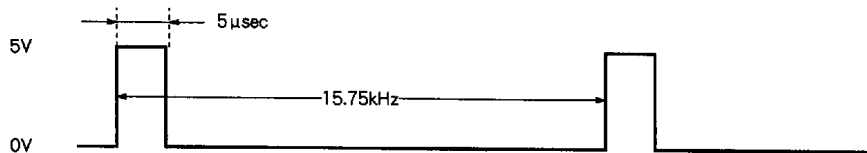

2. SG4 - 1

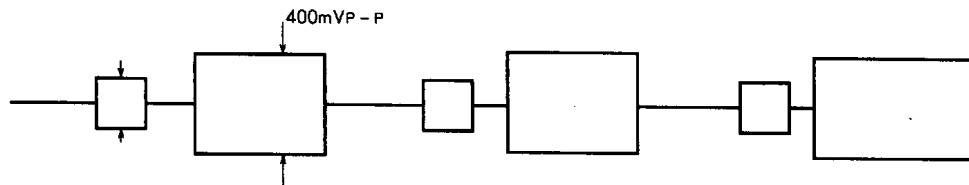

SG4 - 2



3. SG5

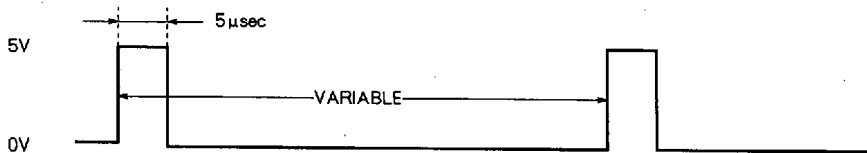

4. SG6



5. SG7



6249826 0022833 007



Note 1. QUASI PAL OPERATING WAVEFORM TIMING

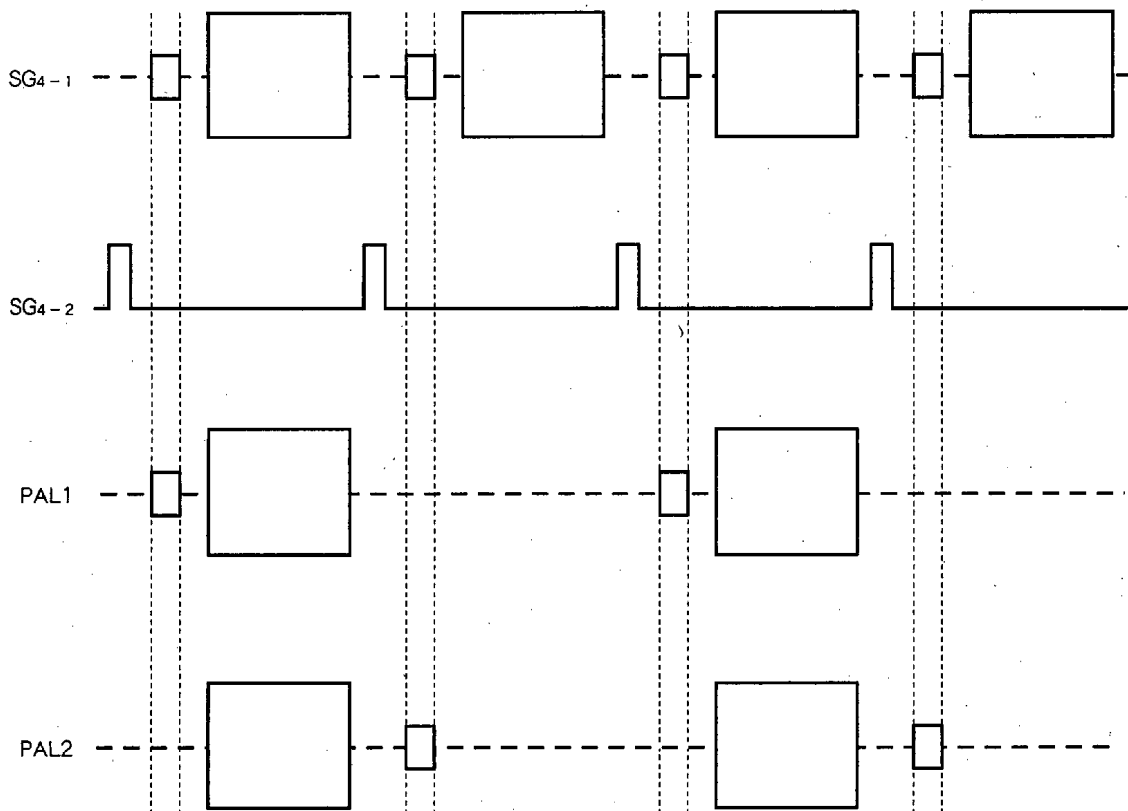

Note 2. EACH WAVEFORM TIMING

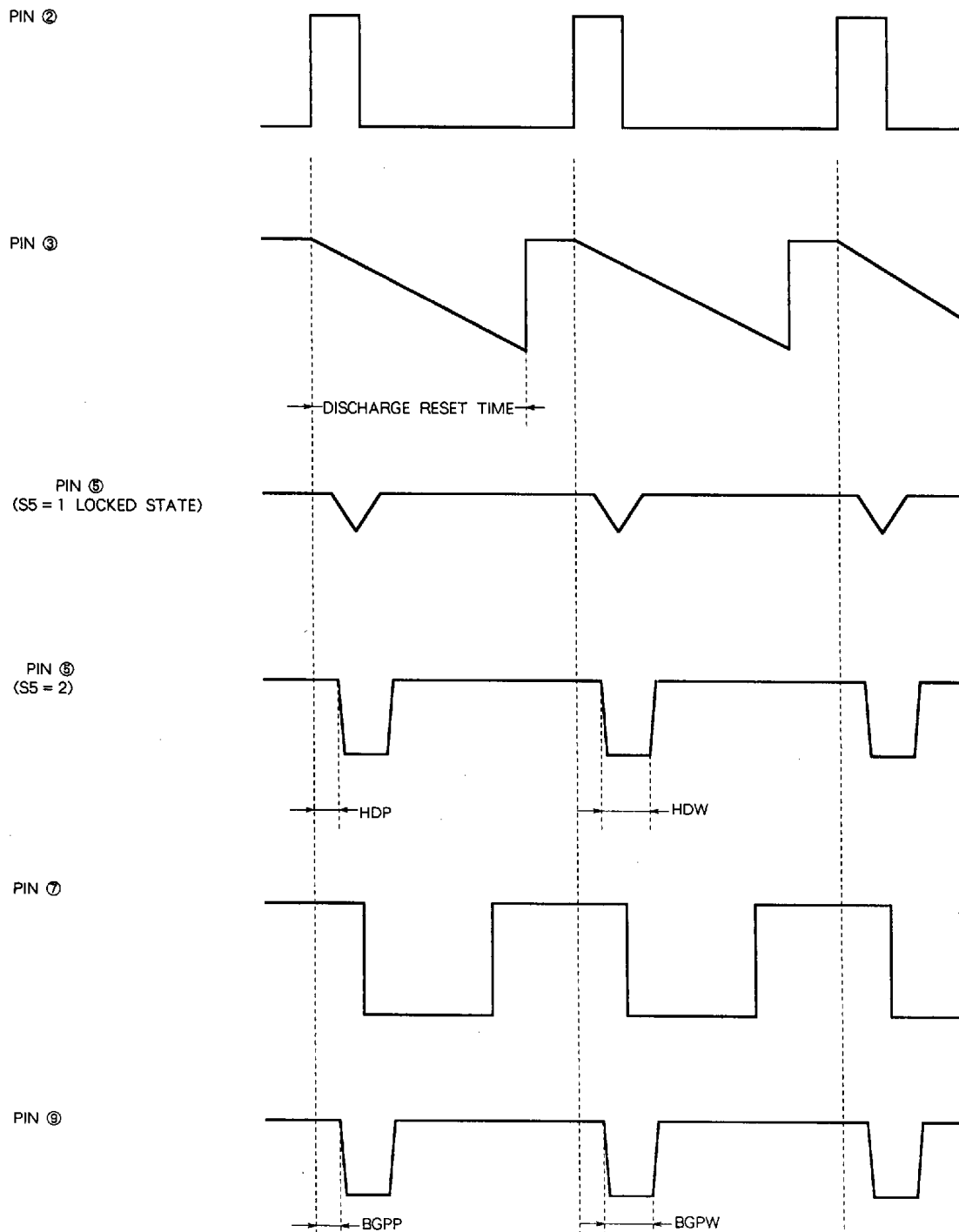

VR6 Adjusting Procedure Before Measurement

o Free run frequency adjustment

Input SG5 ($f = 20\text{kHz}$) to pin ② in the measuring circuit.

Turn S15 ON and set V15 to 5V (free run mode). Adjust

VR6 such that the frequency of pin ⑦ waveform becomes

15.625kHz.

6249826 0022835 98T

M52063SP

NTSC/QUASI PAL TRANSCODER

TEST CIRCUIT

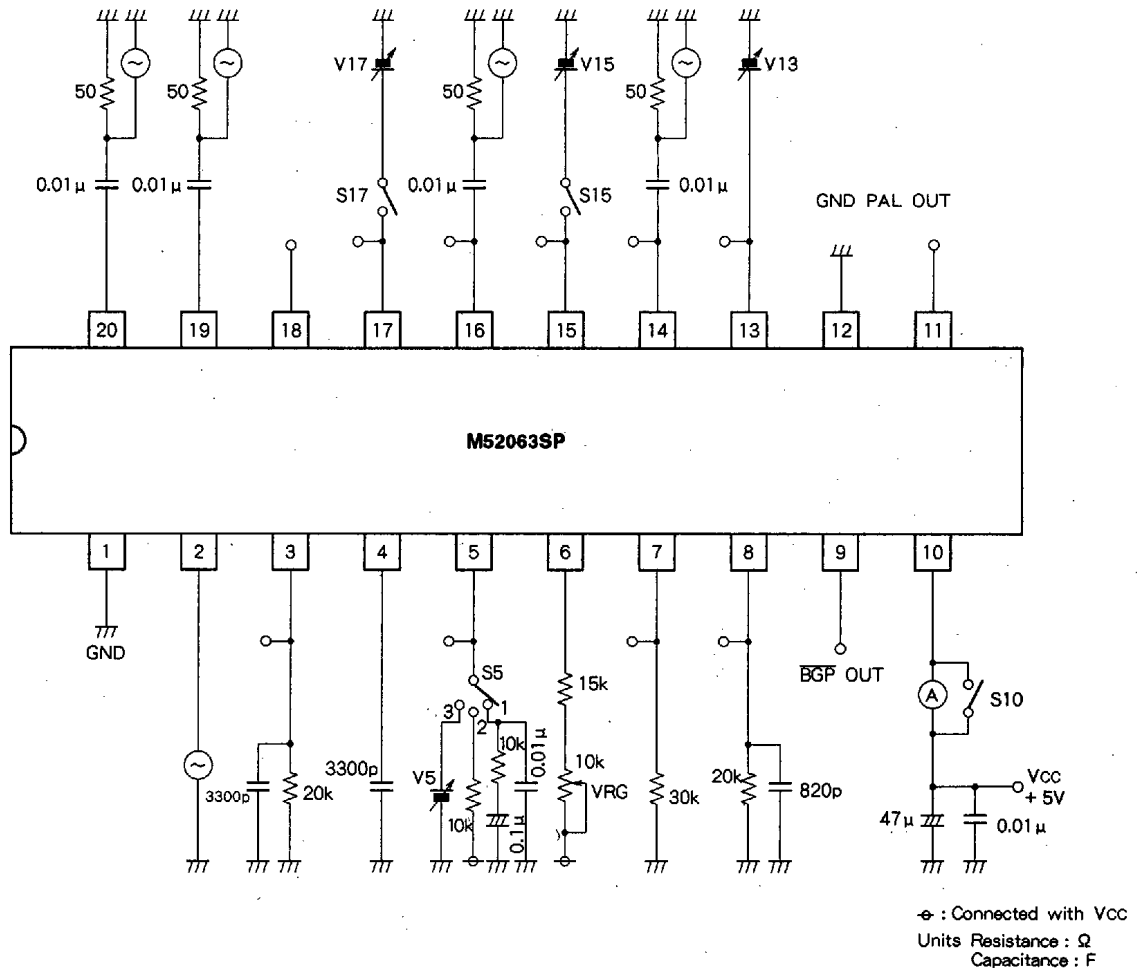

NTSC/QUASI PAL TRANSCODER

APPLICATION EXAMPLE

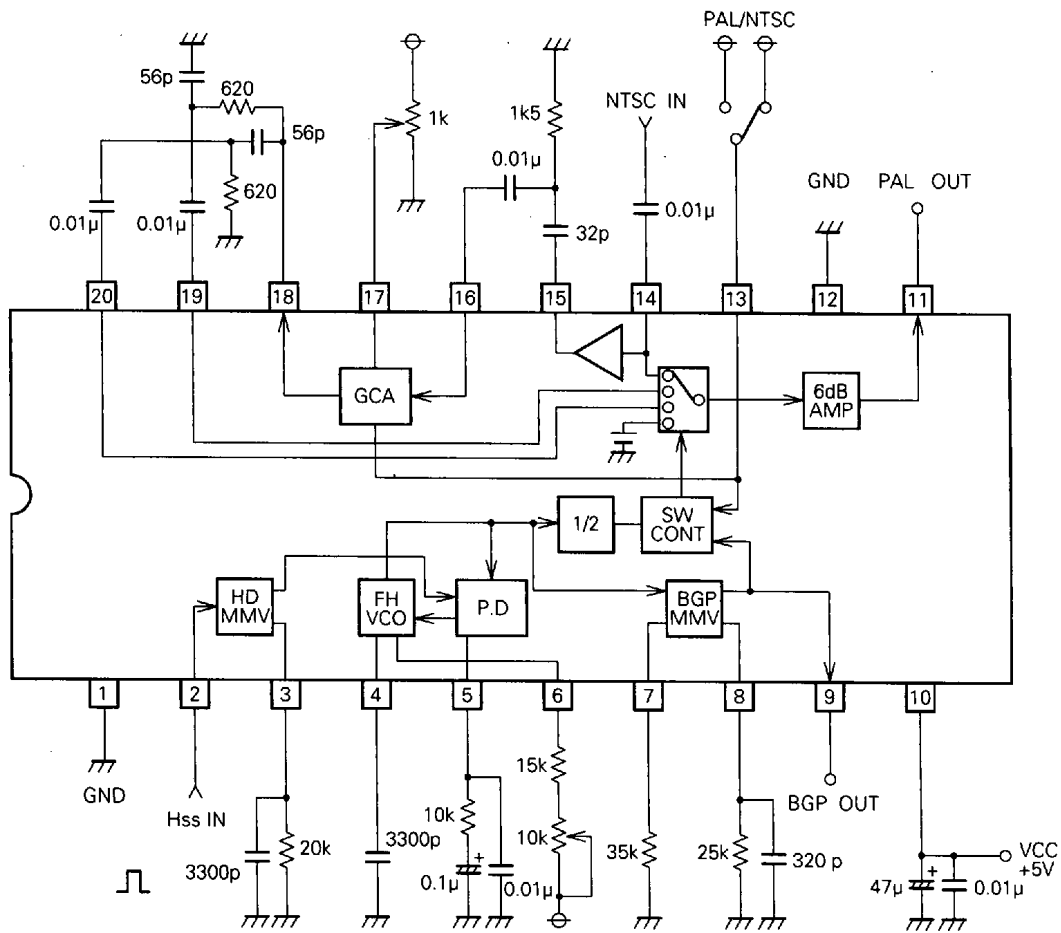

Units Resistance : Ω
Capacitance : F

DESCRIPTION OF PIN

Pin No.	Name	Voltage and wave information	Peripheral circuit of pins
①	DIG GND	—	—
②	Hss IN	<p>5.0VDC 0.0VDC</p>	
③	HALF H KILL	<p>about 3.0VDC about 1.5VDC (2 pin Hss input)</p>	
④	OSC CAP	<p>about 3.5VDC about 3.2VDC</p>	
⑤	AFC FILTER	<p>about 3.0VDC (2 pin Hss input)</p>	

DESCRIPTION OF PIN (cont.)

Pin No.	Name	Voltage and wave information	Peripheral circuit of pins
⑥	for Adj	about 3.0VDC	
⑦	BGP POSI		
⑧	BGP WIDTH		
⑨	BGP OUT		
⑩	Vcc	5.0VDC	—

6249826 0022839 525

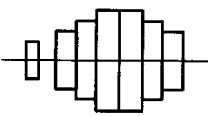
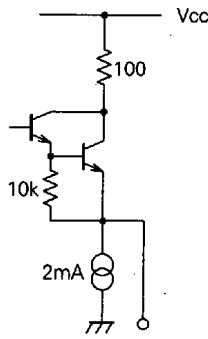
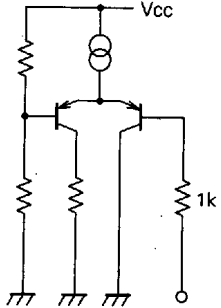
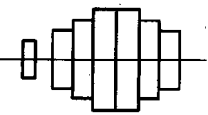
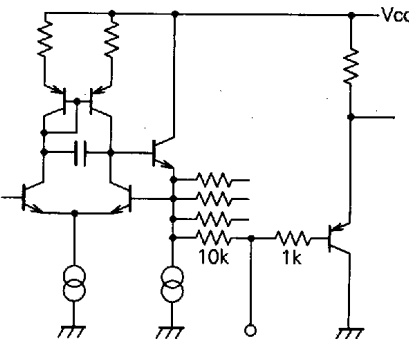
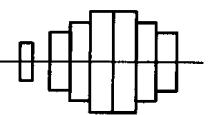
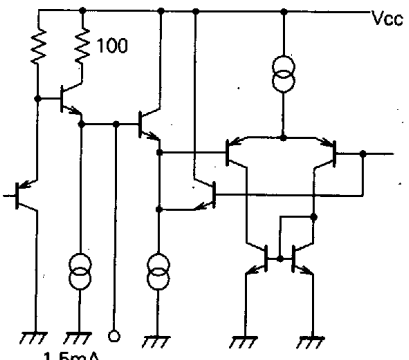

DESCRIPTION OF PIN (cont.)

Pin No.	Name	Voltage and wave information	Peripheral circuit of pins
⑪	PAL OUT	about 2.4VDC 	
⑫	ANA GND	—	—
⑬	PAL/NTSC	—	
⑭	NTSC IN	about 2.3VDC 	
⑮	H.P IN	about 2.3VDC 	

DESCRIPTION OF PIN (cont.)

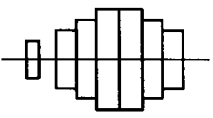
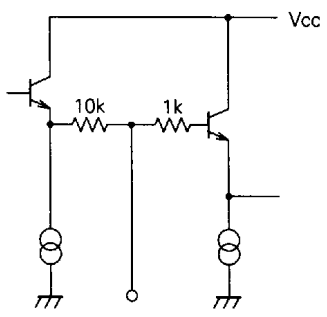
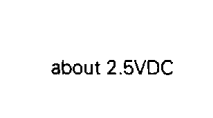
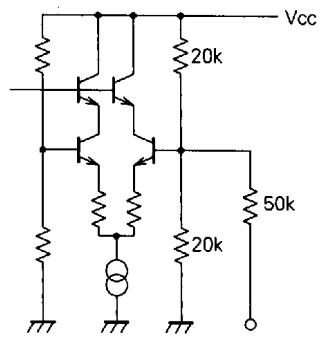
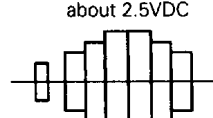
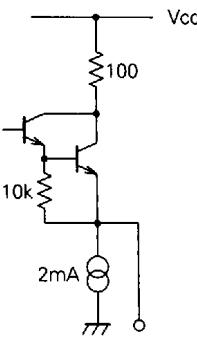
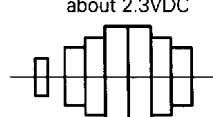
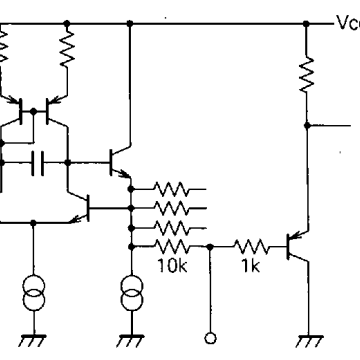
Pin No.	Name	Voltage and wave information	Peripheral circuit of pins
⑰	H.P. OUT	about 2.9VDC 	
⑱	GCA CONT	about 2.5VDC 	
⑲	Burst OUT	about 2.5VDC 	
⑳	- 45 IN	about 2.3VDC 	

DESCRIPTION OF PIN (cont.)

Pin No.	Name	Voltage and wave information	Peripheral circuit of pins
20	+ 45 IN	<p>about 2.3VDC</p> 