

Features

- Compatible with the MH89760B
- Transmit equalizer and 6dB loop around circuit
- 6dB pad for easier loopback testing
- Programmable for varying degrees of equalization

Description

The MH89761 is a programmable transmit equalizer for use with a T1 line interface, specifically the MH89760B. The MH89761 contains a three setting transmit equalizer, and a 6 dB pad for external loop around. The input and output impedance of the circuit is 100Ω. The device is fabricated in thick film hybrid technology and is 2 inches high by 0.5 inches wide. The MH89761 is designed to drive 22 gauge twisted pair from the multiplex equipment to the crossconnect point. Figure 1 shows how the MH89761 is connected to the transmit side of a T1 interface.

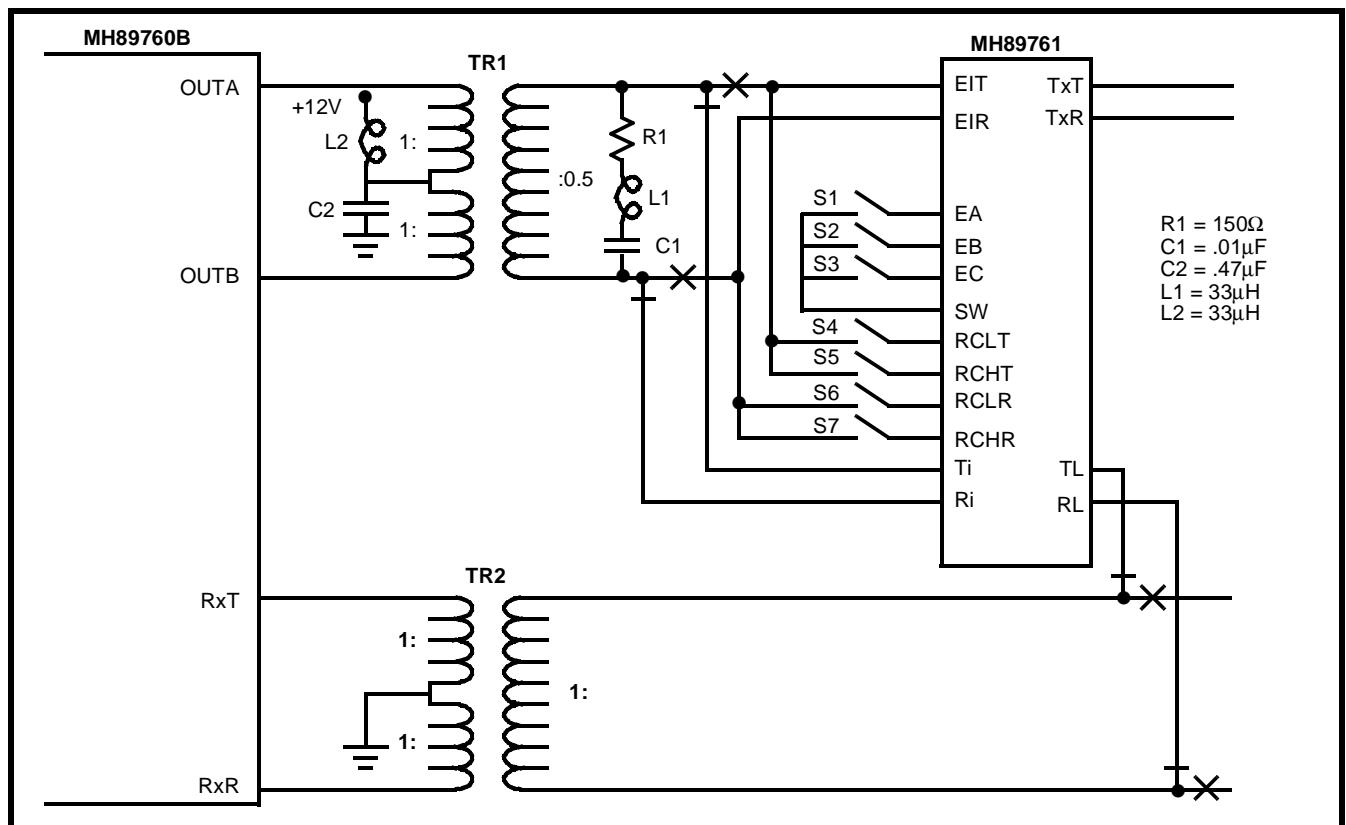
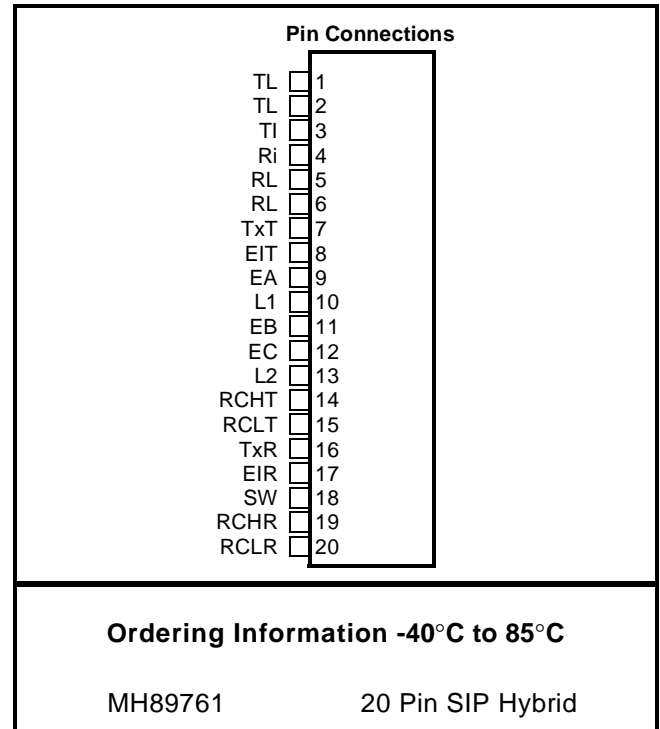

Figure 1 - Connection Diagram

Applications

The MH89761 can be connected to the MH89760B as illustrated in Figure 1. All pins on the MH89761 not shown connected in Figure 1 should be left open. The internal circuit of the equalizer is shown in Figure 2. The MH89761 has two separate circuits; a 6dB pad and an equalizer.

Ti and Ri are inputs to the 6dB pad on the device. The outputs of the pad are brought out on TL and RL. The 6dB pad is provided to loopback the transmit signal back to the receive without altering the equalizer settings. The 4 pole double throw relay shown in Figure 1 permits connection of the output of the transformer TR1 to either the equalizer or the fixed 6dB pad. For normal operation and transmission out to the line, the transformer should be connected to the equalizer inputs EiT and EIR. Enabling the relay will switch the connection through the 6dB pad for loopback diagnostics.

The MH89761 is designed to accept output from the secondary of the T1 transmit transformer and condition it for transmission over twisted pair. The seven switches (S1 to S7) permit configuration of the equalizer for different line lengths. The pulse amplitude at the secondary of TR1 is approximately 6V. Passing this signal through the equalizer with zero line length setting on the switches will result in attenuation of the pulse by 6dB. This will ensure that the pulse fits in the template shown in Figure 3 and meets DSX-1^① requirements. By switching in different C and L components, the frequency and phase response of the equalizer can be altered as shown in Figures 4 and 5. Note that the circuit attenuates lower frequencies more than higher frequencies. Consequently, when a pulse is passed through the equalizer, lower frequency components in the signal are attenuated more than higher frequency components. The intention is to compensate for the attenuation properties of twisted pair cable, which tends to attenuate higher frequencies more than lower frequencies. The net result is that a pre-equalized pulse will meet DSX pulse requirements after traversing a specific length of cable.

The cable length indicated along with the equalizer switch settings in Figure 4 are specific to 22 awg ABAM cable interfaced to an MH89760B equipped with a Filtran^② TFS2573 transformer. Different equalizer settings may be more appropriate for other cable and transformer types. Figure 6 shows the generic switch settings for different levels of equalization.

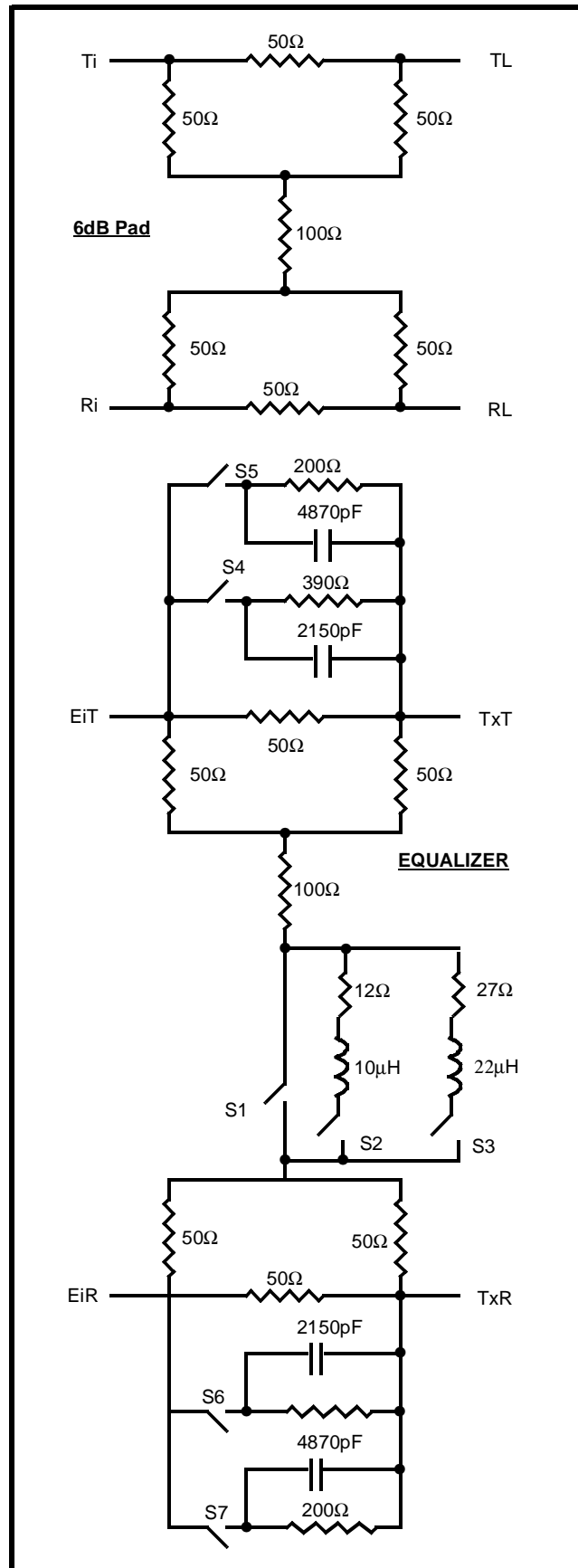

Figure 2 - 6dB Pad and Equalizer Pin

① Reference: ANSI T1.102 - 1987, Section 2.2
 ② Manufacturer: Filtran Ltd. (613) 226-1626

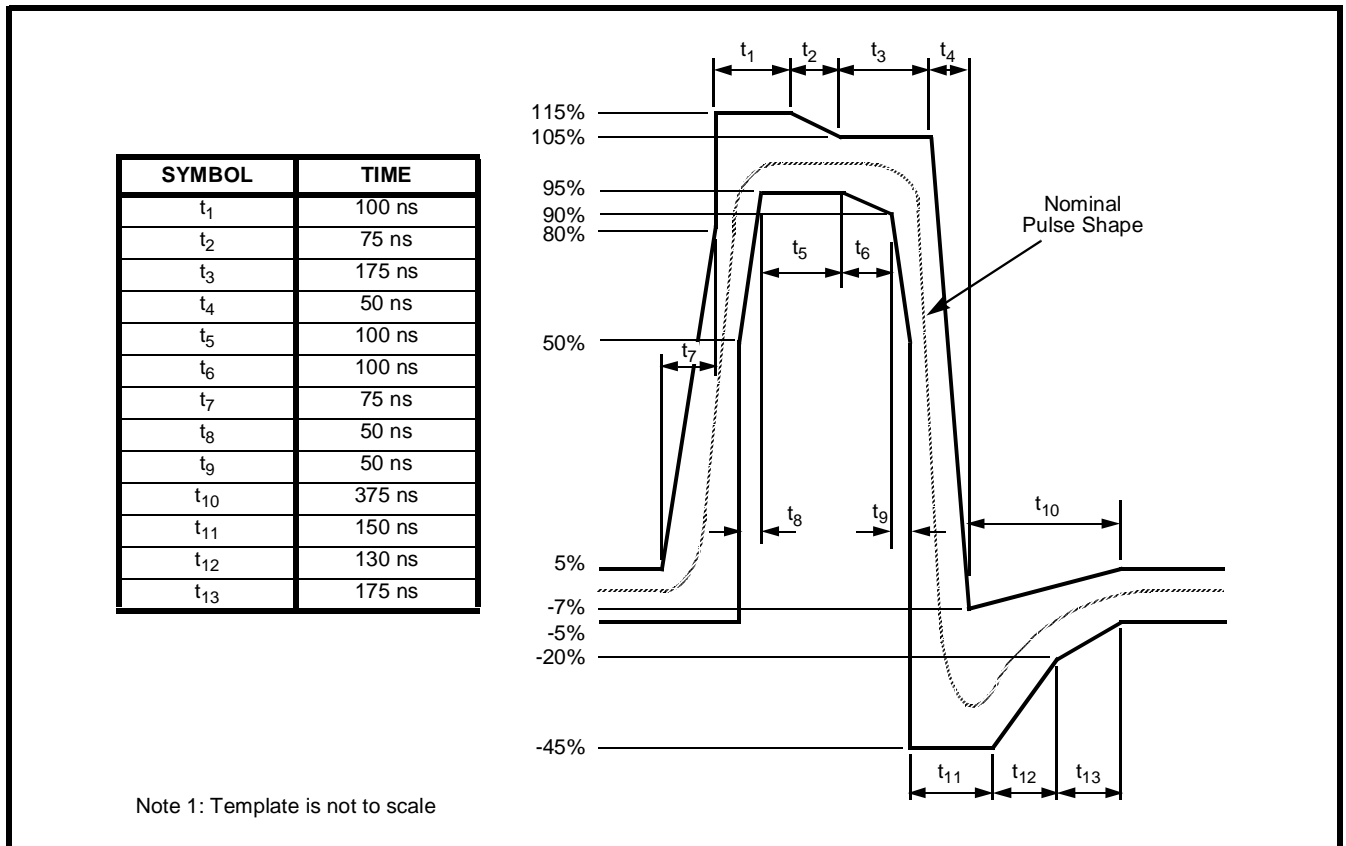

Figure 3 - DSX-1 Line Pulse Template (Reference: ANSI T1.102-1987)

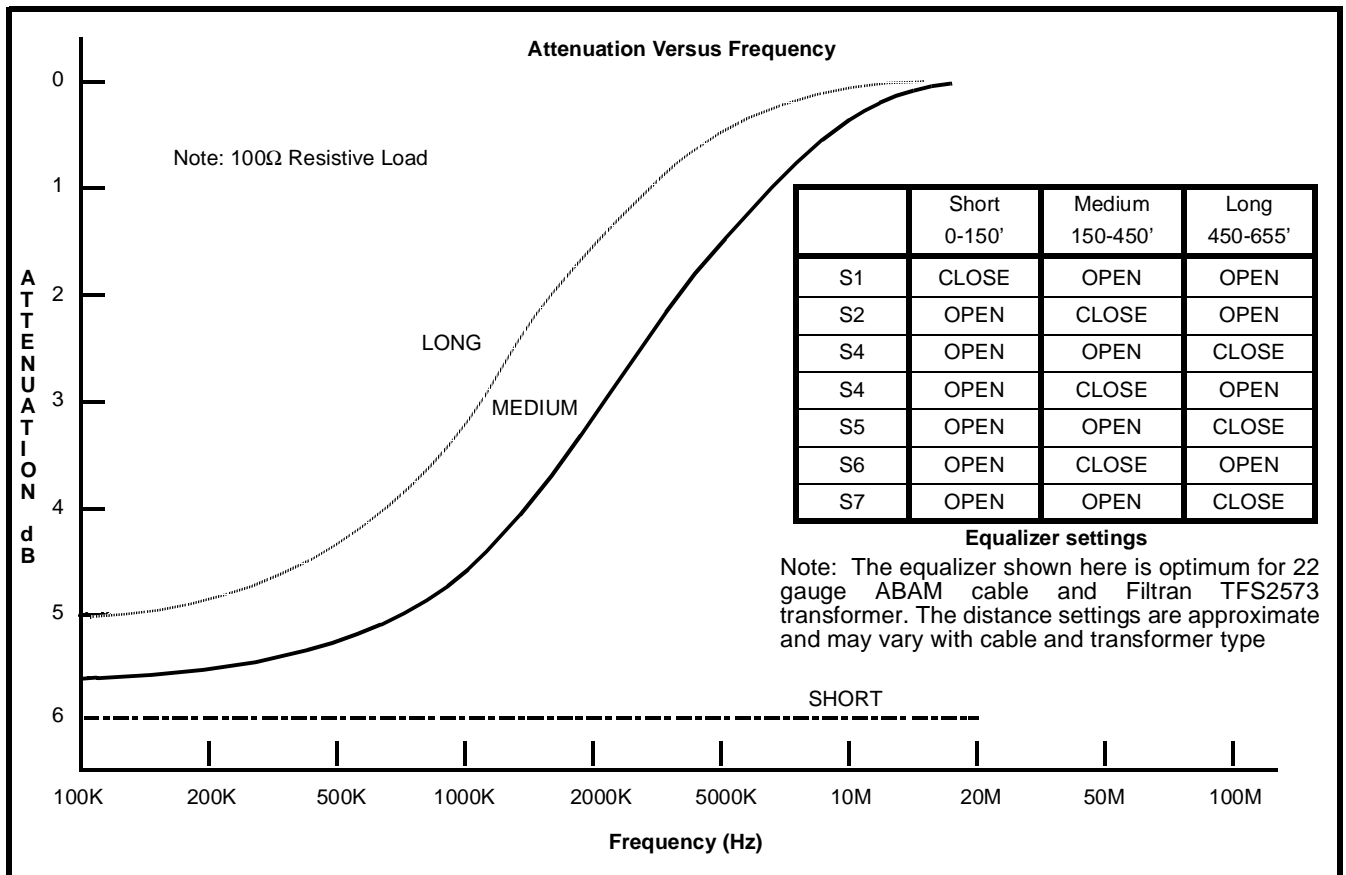

Figure 4 - Typical Frequency Response of the Equalizers

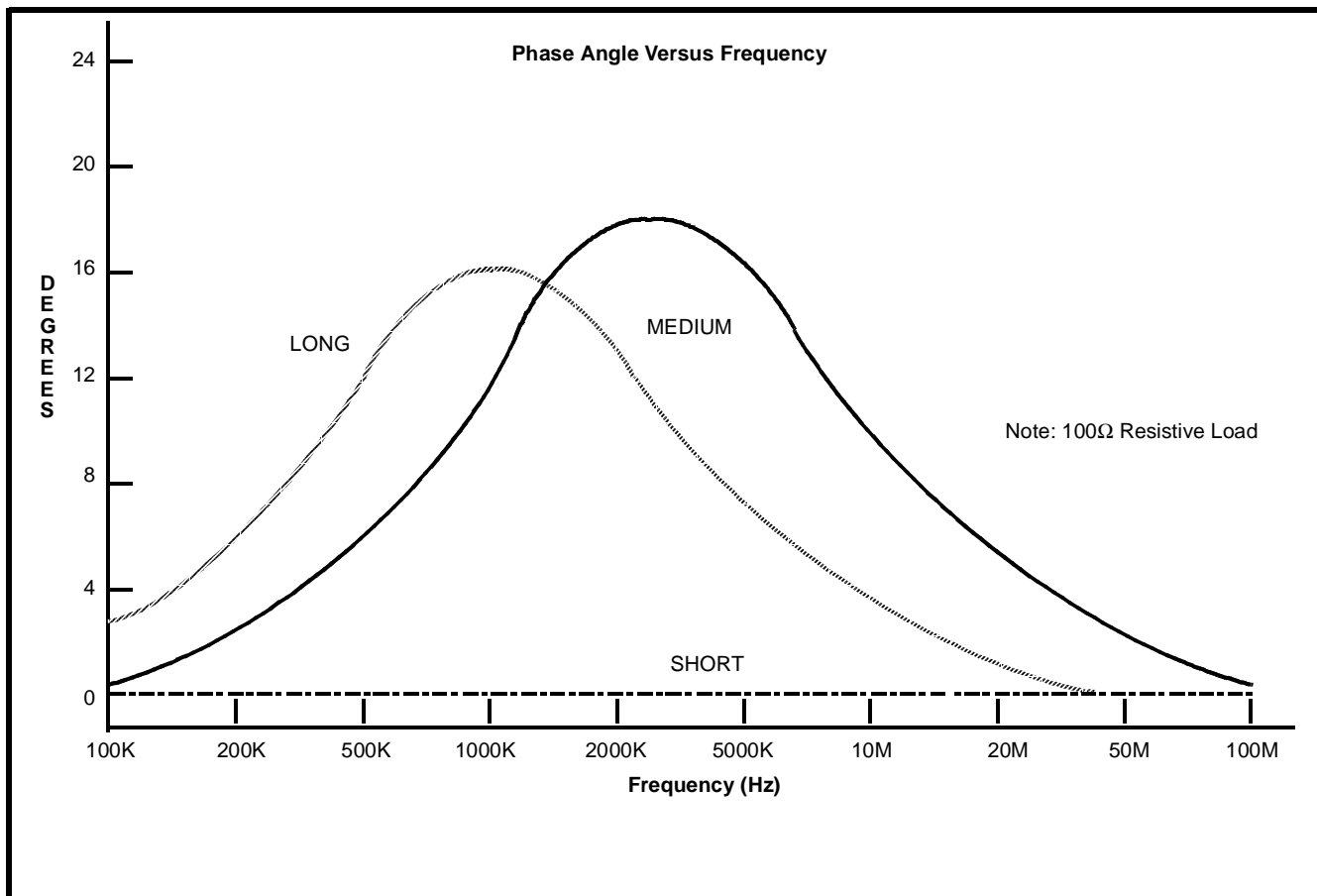

Figure 5 - Typical Phase Response of the Equalizers

- = SWITCH OPENED
X = SWITCH CLOSED

S1	X	-	-	X	-	-	X	-	-	X	-	-
S2	-	X	-	-	X	-	-	X	-	-	X	-
S3	-	-	X	-	-	X	-	-	X	-	-	X
S4	-	-	-	X	X	X	-	-	-	X	X	X
S5	-	-	-	-	-	-	X	X	X	X	X	X
S6	-	-	-	X	X	X	-	-	-	X	X	X
S7	-	-	-	-	-	-	X	X	X	X	X	X

↑ NO EQUALIZATION Short Cables INCREASING EQUALIZATION ↑ MAX. EQUALIZATION Long Cables

Figure 6 - Switch Settings for Different Levels of Equalization

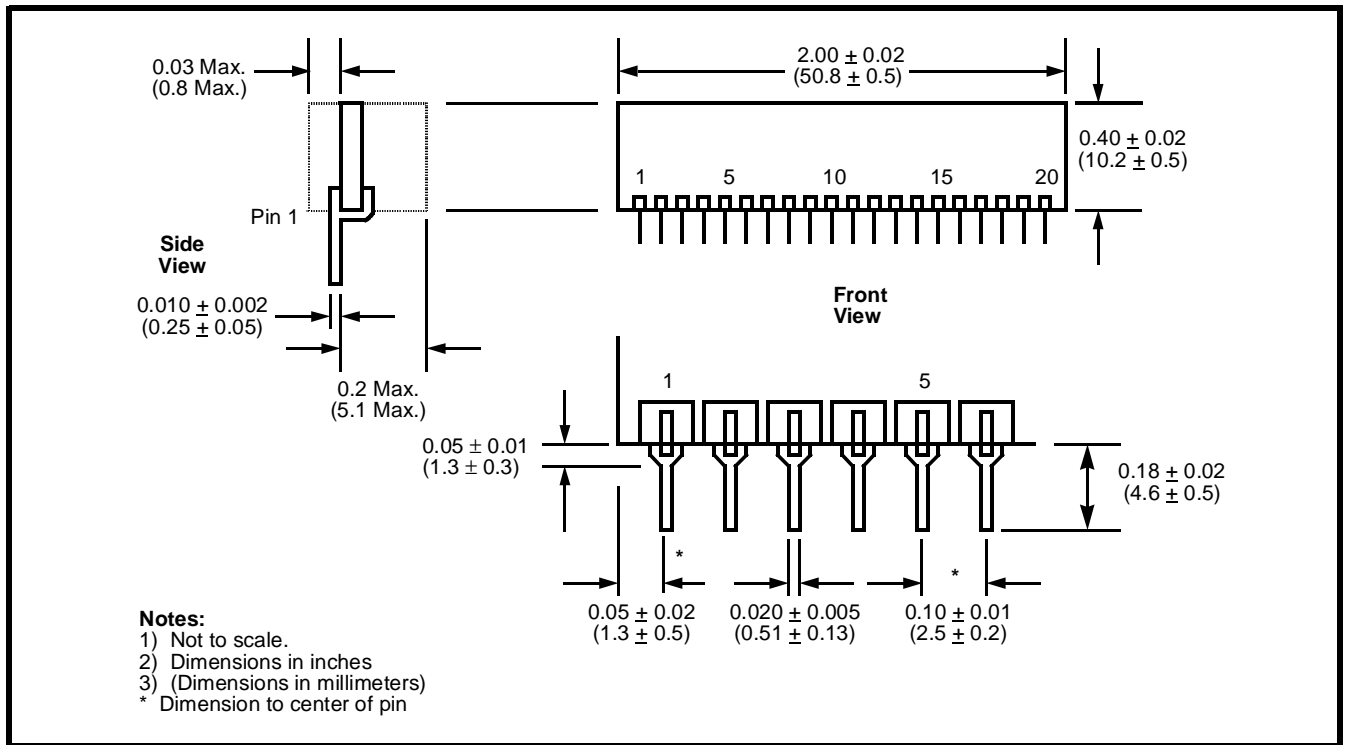

Figure 7 - Mechanical Data

NOTES: