

**PRELIMINARY**

**M61515FP**

Notice : This is not a final specification.  
 some parametric limits are subject to change.

**TONE CONTROL/VOLUME CONTROL**

**DESCRIPTION**

The M61515FP is the sound controller powered by "QSurround" system.  
 The "QSurround" system decodes and virtualizes multi-speaker surround sound from various matrix surround encoded sources such as:  
 Dolby Surround, stereo downmixed AC-3, stereo downmixed DTS.  
 Produces normal and wide 3D sound expansion from any stereo input signal.

(Note) This device is produced under license from QSound Lab,Inc.(Canada) .

**FEATURES**

- Built-in "QSurround" sound technology
- Electronic volume.  
 0 ~ -84dB, infinitesimal
- 2-band tone control  
 Bass(0 ~ +21dB/3dB STEP)  
 Treble(0 ~ +9dB/3dB STEP)
- 5 input selector(The fifth input can be used as REC OUT or MIC MIX.)

**RECOMMENDED OPERATING CONDITIONS**

Supply voltage range ----- ±2.25 ~ ±2.75V

**SYSTEM BLOCK DIAGRAM**

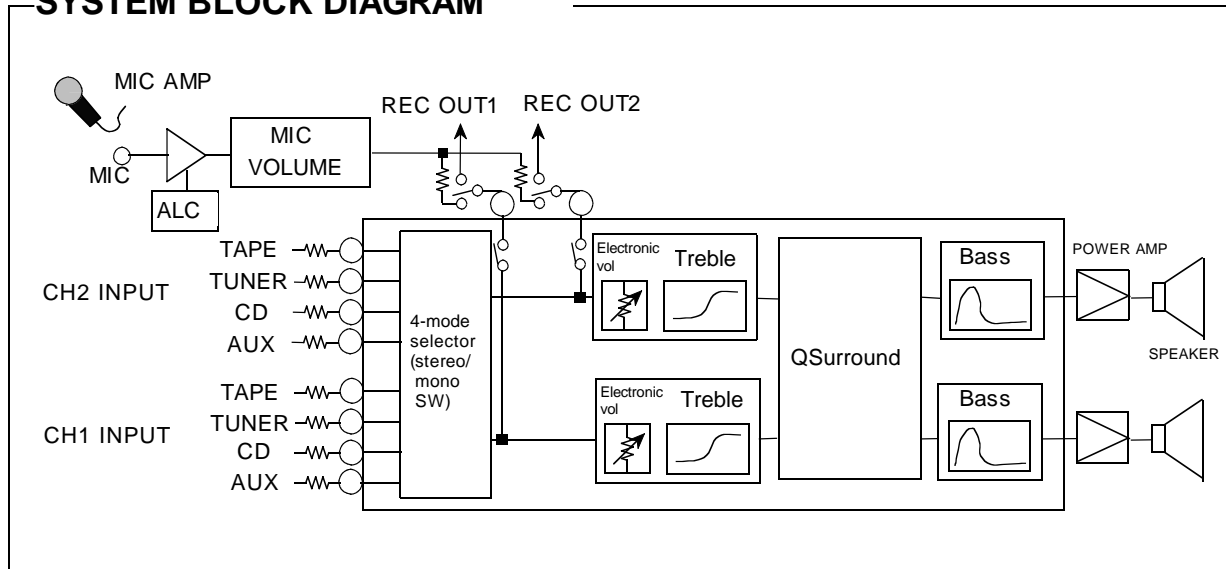

PRELIMINARY

M61515FP

Notice : This is not a final specification.  
 some parametric limits are subject to change.

TONE CONTROL/VOLUME CONTROL

BLOCK DIAGRAM

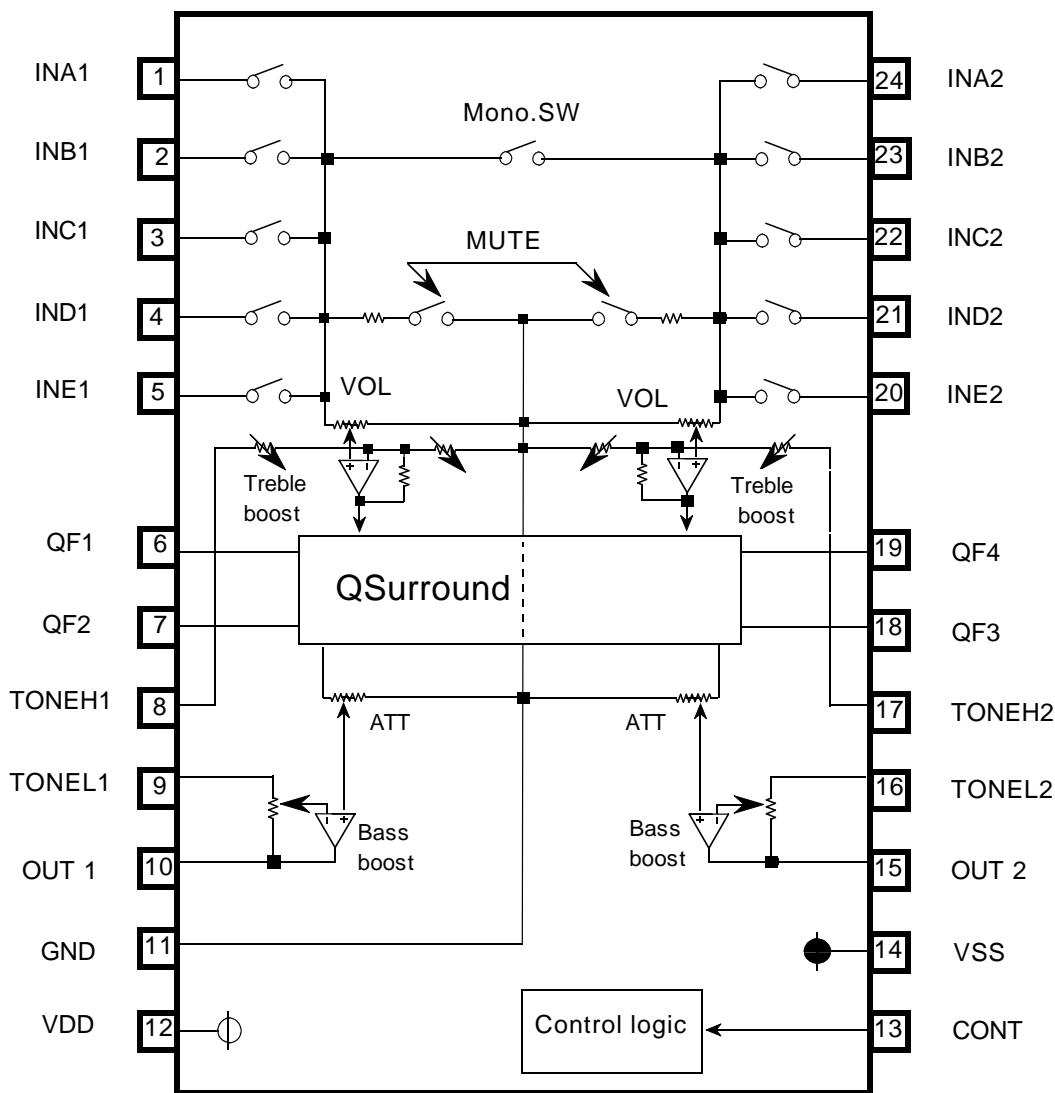

Units Resistance :Ω  
 Capacitance: F

PRELIMINARY

M61515FP

Notice : This is not a final specification.  
some parametric limits are subject to change.

TONE CONTROL/VOLUME CONTROL

**PIN DESCRIPTION**

Pin No.	Name	Function
1	IN A1	INPUTs of the channel 1  The switch of INE can be controlled independently. Please set "ALL OFF" mode when the switch of E is only ON.
2	IN B1	
3	IN C1	
4	IN D1	
5	IN E1	
6	QF1	QSurround filter 1
7	QF2	QSurround filter 2
8	TONEH1	Treble control adjustment of the channel 1
9	TONEL1	Bass control adjustment of the channel 1
10	OUT1	OUTPUT of the channel 1
11	GND	Ground
12	VDD	Supply voltage(+)
13	CONT	Control data input from a microcontroller
14	VSS	Supply voltage(-)
15	OUT2	OUTPUT of the channel 2
16	TONEL2	Bass control adjustment of the channel 2
17	TONEH2	Treble control adjustment of the channel 2
18	QF3	QSurround filter 3
19	QF4	QSurround filter 4
20	IN E2	INPUTs of the channel 2  The switch of INE can be controlled independently. Please set "ALL OFF" mode when the switch of E is only ON.
21	IN D2	
22	IN C2	
23	IN B2	
24	IN A2	

PRELIMINARY

M61515FP

Notice : This is not a final specification.  
some parametric limits are subject to change.

TONE CONTROL/VOLUME CONTROL

**ABSOLUTE MAXIMUM RATINGS**  
(Ta=25 °C,unless otherwise noted)

Symbol	Parameter	Test conditions	Rating	Unit
VDD-VSS	Supply voltage		6.0	V
$K_{\theta}$	Thermal derating	Note:1	5	mW/°C
Pd	Power dissipation		500	mW
Topr	Operating temperature		-20 ~ 75	°C
Tstg	Storage temperature		-40 ~ 125	°C

**Thermal derating(maximum rating)**

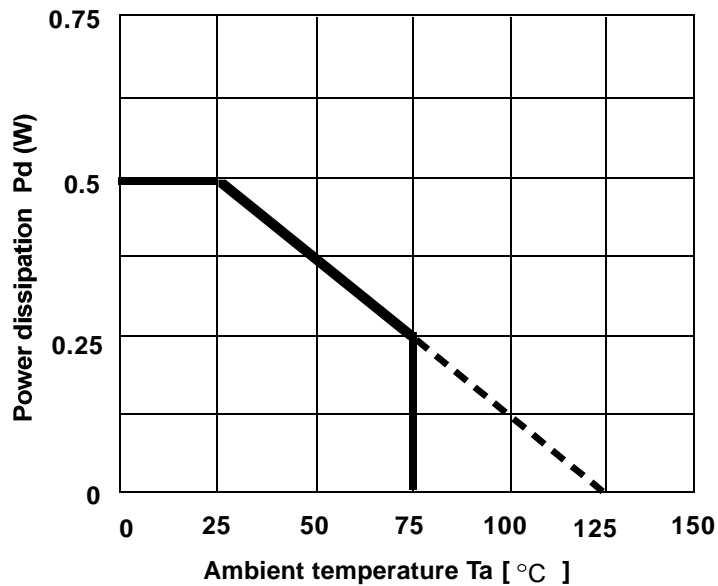

Note.1 reference PC Board

Size :70mmX70mm  
Thickness:1.6mm  
Material :glass epoxy

Copper pattern dimension  
Width :0.25mm  
Length :25 ~ 30mm/lead  
Thickness:18um

**Recommended operating conditions**

Symbol	Parameter	Pin No.	Condition	Limits			Unit
				min.	typ.	max.	
VDD	Supply voltage(+)	12		2.25	2.5	2.75	V
VSS	Supply voltage(-)	14		-2.75	-2.5	-2.25	
CONT	Control data input v oltage	13		GND	—	VDD	

PRELIMINARY

M61515FP

Notice : This is not a final specification.  
some parametric limits are subject to change.

TONE CONTROL/VOLUME CONTROL

CONTROL SIGNALS SPECIFICATION

(1) Wave form

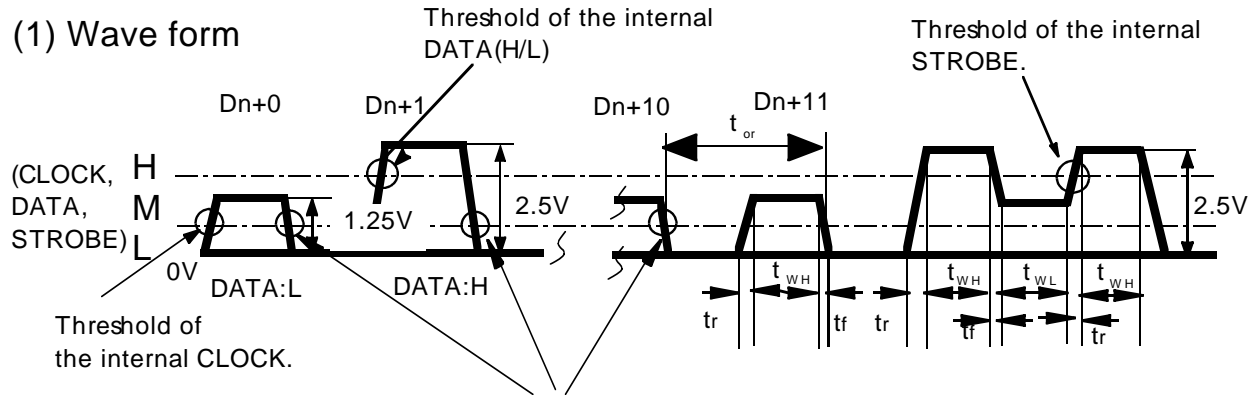

The internal DATA latch at the falling edges of this clock signal.

(2) Voltage control signal

Digital input signal		Condition	Limits			Unit
			min.	typ.	max.	
L signal	L	VDD=2.5V, VSS=-2.5V	GND	—	0.4	V
M signal	M	VDD=2.5V, VSS=-2.5V	1.0	1.25 (VDD/2)	1.5	
H signal	H	VDD=2.5V, VSS=-2.5V	2.1	—	VDD	

(3) Timing control signal

Symbol	Parameter	Limits			Unit
		min	typ	max	
t <sub>cr</sub>	Cycle time of digital signal	8	—	—	μsec
t <sub>wH</sub>	Pulse width of digital signal("H"level)	3.6	—	—	
t <sub>wLC</sub>	Pulse width of digital signal("L"level)	3.6	—	—	
t <sub>r</sub>	Rise time of digital signal	—	—	0.4	
t <sub>f</sub>	Fall time of digital signal	—	—	0.4	

(4) Control signal example(Refer to page 6 on the control data)

An example of the mode control

BYPASS/SURROUND SW: SURROUND  
VOL/TREBLE SHARE AMP GAIN: 20dB  
INPUT : INA,  
VOLUME : 0dB  
MUTE : OFF

SURROUND MODE: QSurround  
SURROUND EFFECT: 0dB  
MODE: STEREO  
BASS: 18dB  
TREBLE: 6dB  
RECOUT: ON(INE)

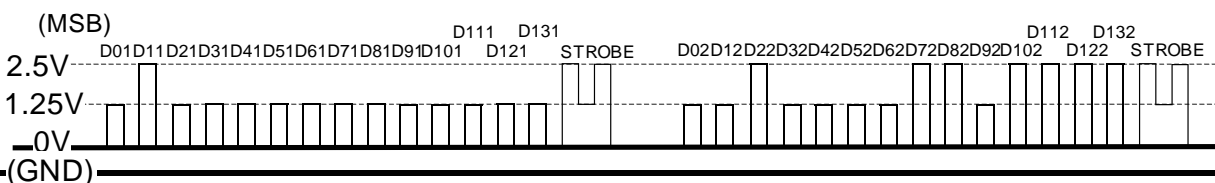

# PRELIMINARY

# M61515FP

Notice : This is not a final specification.  
some parametric limits are subject to change.

## TONE CONTROL/VOLUME CONTROL

**CONTROL DATA FORMAT** \*It's necessary to set up the all control data after power on.

### (1) INPUT DATA

(MSB) ← Input order

D01	D11	D21	D31	D41	D51	D61	D71	D81	D91	D101	D111	D121	D131
Slot1	0	Bypass/ Surround SW	Vol/Treble share amp gain SW 0:20dB 1:18dB 2:16dB 3:14dB	INPUT 0:IN A 1:IN B 2:IN C 3:IN D	D2 to D6:(a)Master volume condition					MUTE ON/OFF 0:OFF 1:ON  (INPUT ALL OFF)	CHIP/SLOT SELECT 0:select 1:no select 2:no select 3:no select		

D02	D12	D22	D32	D42	D52	D62	D72	D82	D92	D102	D112	D122	D132
Slot2	Surround mode	Surround effect	Mode select 0:stereo 1:mono1 only 2:mono2 only 3:mono1+2	Bass(boost) 0:0dB, 1:3dB, 2:6dB, 3:9dB, 4:12dB, 5:15dB, 6:18dB, 7:21dB	Treble(boost) 0:0dB,1:3dB 2:6dB,3:9dB	IN E ON/OFF 0:OFF 1:ON	CHIP/SLOT SELECT 0:no select 1:no select 2:no select 3:select						

#### (a) Master volume

ATT	D61	D71	D81	D91	D101
-0.0dB	0	0	0	0	0
-2.0dB	1	0	0	0	0
-4.0dB	0	1	0	0	0
-6.0dB	1	1	0	0	0
-8.0dB	0	0	1	0	0
-10.0dB	1	0	1	0	0
-12.0dB	0	1	1	0	0
-14.0dB	1	1	1	0	0
-16.0dB	0	0	0	1	0
-18.0dB	1	0	0	1	0
-20.0dB	0	1	0	1	0
-22.0dB	1	1	0	1	0
-24.0dB	0	0	1	1	0
-26.0dB	1	0	1	1	0
-28.0dB	0	1	1	1	0
-30.0dB	1	1	1	1	0
-32.0dB	0	0	0	0	1
-34.0dB	1	0	0	0	1
-36.0dB	0	1	0	0	1
-40.0dB	1	1	0	0	1
-44.0dB	0	0	1	0	1
-48.0dB	1	0	1	0	1
-52.0dB	0	1	1	0	1
-56.0dB	1	1	1	0	1
-60.0dB	0	0	0	1	1
-64.0dB	1	0	0	1	1
-68.0dB	0	1	0	1	1
-72.0dB	1	1	0	1	1
-76.0dB	0	0	1	1	1
-80.0dB	1	0	1	1	1
-84.0dB	0	1	1	1	1
the infinitesimal	1	1	1	1	1

#### (b) Input select

Input select	D41	D51	D111	D112	
IN A	0	0	0	0	
IN B	1	0			
IN C	0	1			
IN D	1	1			
IN A to D all OFF	*	*	1	1 *1	
IN A-D select	IN E on	A: 0	0	0	1 *2
		B: 1	0		
		C: 0	1		
		D: 1	1		

\*1) The input impedance is about 5k as input INE.

\*2) INE can be controlled independently.  
It can be used as Rec output.

#### (c) Mode control

Mode	D42	D52
stereo	0	0
mono1 only	1	0
mono2 only	0	1
mono1+2	1	1

#### (d) Treble control

Treble	D92	D102
0dB	0	0
3dB	1	0
6dB	0	1
9dB	1	1

#### (e) Bass control

Bass	D62	D72	D82
0dB	0	0	0
3dB	1	0	0
6dB	0	1	0
9dB	1	1	0
12dB	0	0	1
15dB	1	0	1
18dB	0	1	1
21dB	1	1	1

#### (f) Chip/Slot control

Chip/Slot	D12*	D13*
select(slot1)	0	0
no select	1	0
no select	0	1
select(slot1)	1	1

#### (g) Treble amp gain SW

Gain SW	D21	D31
20dB	0	0
18dB	1	0
16dB	0	1
14dB	1	1

#### (h) Bypass/ Surround SW

Bypass/ Surround SW	D11
Bypass	0
Surround	1

#### (i) Surround mode

Mode	D02	D12
QSurround	0	0
REAR Surround	1	0
REAR Normal surround	0	1
Normal surround	1	1

#### (j) Surround effect

(Valid in the surround mode.  
Set 0dB at QSurround.)

Effect	D22	D32
+3dB	0	0
0dB	1	0
-3dB	0	1
-6dB	1	1

# PRELIMINARY

# M61515FP

Notice : This is not a final specification.  
 some parametric limits are subject to change.

## TONE CONTROL/VOLUME CONTROL

### (2) NOTICE OF CONTROL DATA

1. Input only the control data at (1) INPUT DATA.
2. The interval of data transmission from the microcontroller is over 0.1 sec. This is waiting time for soft-switching to reduce the shocknoise.
3. It's necessary to set up the all control data after power-on, although the internal circuit is forced as below, when  $(VDD-VSS) \leq 3.3V(TYP)$ .

Parameter	Condition
Gain SW	18dB
Input select	ALL OFF
Master volume	infinitesimal
MUTE	ON(Input ALLOFF)
Surround effect	- 6dB
Surround	OFF
Surround mode	QSurround
Mode select	stereo
Bass	0dB
Treble	0dB
IN E	ON

PRELIMINARY

M61515FP

Notice : This is not a final specification.  
 some parametric limits are subject to change.

TONE CONTROL/VOLUME CONTROL

ELECTRICAL CHARACTERISTICS

(VDD=2.5V, VSS=-2.5V, f=1kHz, Vi=100mV(rms), VOL=0dB, BASS=0dB, TREBLE=0dB, VOL/TREBLE SHARE AMP=18dB, SURROUND=BYPASS, RL=10K, Ta=25°C, unless otherwise noted)

Symbol	Parameter	Condition	Limits			Unit	
			min.	typ.	max.		
IDD	Circuit current of positive power supply	Quiescent	—	30	45	mA	
ISS	Circuit current of negative power supply	Quiescent	—	-30	-45	mA	
Gv1	Voltage gain (selector)	Vol/Treble share amp gain=18dB By pass	16	18	20	dB	
Gv2	Voltage gain (tone control)	Vol/Treble share amp gain=18dB QSurround mode Vi=20mVrms	25.5	27.5	29.5	dB	
Vomax	Maximum output voltage	RL=10k, THD=1%	1.2	1.6	—	Vrms	
THD	Total harmonic distortion	BW=400 ~ 30kHz	—	0.02	0.08	%	
No1	Output noise voltage	JIS-A, Rg=5.1k, VOL=the infinitesimal BYPASS	—	6	15	μVrms	
No2		JIS-A, Rg=5.1k, VOL=the infinitesimal QSurround mode	—	11	30	μVrms	
ATTmax	Maximum attenuation	Output reference level (Vo=1Vrms), ATT=the infinitesimal, JIS-A	—	-95	-90	dB	
GB1	Bass boost	3dB	f=1kHz, Vo=80mVrms	1.5	3	4.5	dB
GB2		6dB		4.5	6	7.5	
GB3		9dB		7.5	9	10.5	
GB4		12dB		10.5	12	13.5	
GB5		15dB		13.5	15	16.5	
GB6		18dB		16.5	18	19.5	
GB7		21dB		19.5	21	22.5	
GT1	Treble boost	3dB	f=1kHz, Vo=80mVrms	1.5	3	4.5	dB
GT2		6dB		4.5	6	7.5	
GT3		9dB		7.5	9	10.5	



# PRELIMINARY

# M61515FP

Notice : This is not a final specification.  
some parametric limits are subject to change.

## TONE CONTROL/VOLUME CONTROL

### FUNCTION DESCRIPTION

#### (1) Equivalent circuit of the bass boost

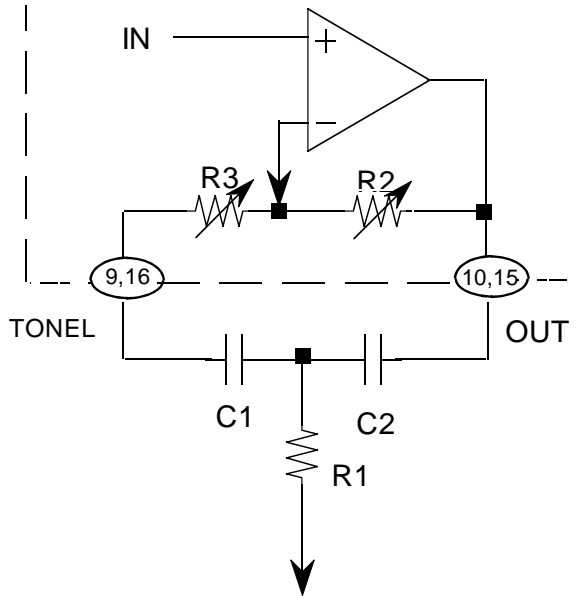

$$F_0 = \frac{1}{2\pi \sqrt{R_1(R_2+R_3)C_1C_2}} \quad (\text{Hz})$$

$$Q = \frac{1}{C_1+C_2} \sqrt{\frac{C_1C_2R_2}{R_1}}$$

$$(C_1=C_2) \quad G_v = 20 \log \frac{\frac{R_2+R_3}{R_1} + 2}{\frac{R_3}{R_1} + 2} \quad (\text{dB})$$

R2,R3 (typical)

Bass boost	3dB	6dB	9dB	12dB	15dB	18dB	21dB
Resistor	R2 15.4	25.7	32.9	38.7	41.6	44.2	46
(k)	R3 30.6	20.3	13.1	7.3	4.4	1.8	0

#### (2) Equivalent circuit of the treble boost

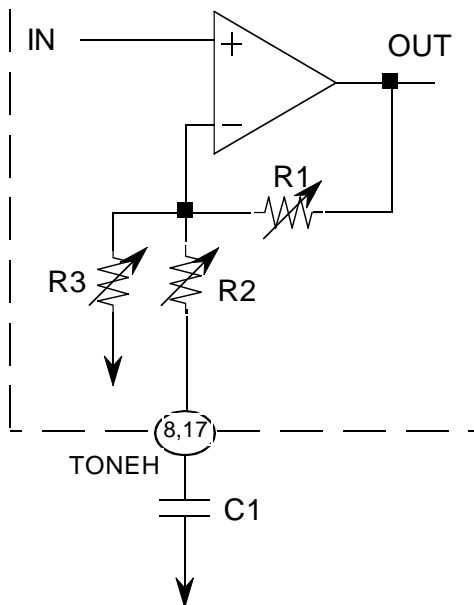

$$F_c = \frac{1}{2\pi \cdot R_2 \cdot C_1} \quad (\text{Hz})$$

$$G_v = 20 \log \frac{R_1 + \{(R_2 + Z_c) // R_3\}}{(R_2 + Z_c) // R_3} \quad (\text{dB})$$

$$Z_c = \frac{1}{j\omega C_1} \quad (\text{ohm})$$

R2 (typical)

Treble boost	3dB	6dB	9dB
R2 (k)	5.3	2.2	1.2

R1,R3 (typical)

Gain	14dB	16dB	18dB	20dB
R1 (k)	10.88	13.65	17.21	21.60
R3 (k)	2.72	2.57	2.48	2.40

PRELIMINARY

M61515FP

Notice : This is not a final specification.  
 some parametric limits are subject to change.

TONE CONTROL/VOLUME CONTROL

APPLICATION EXAMPLE

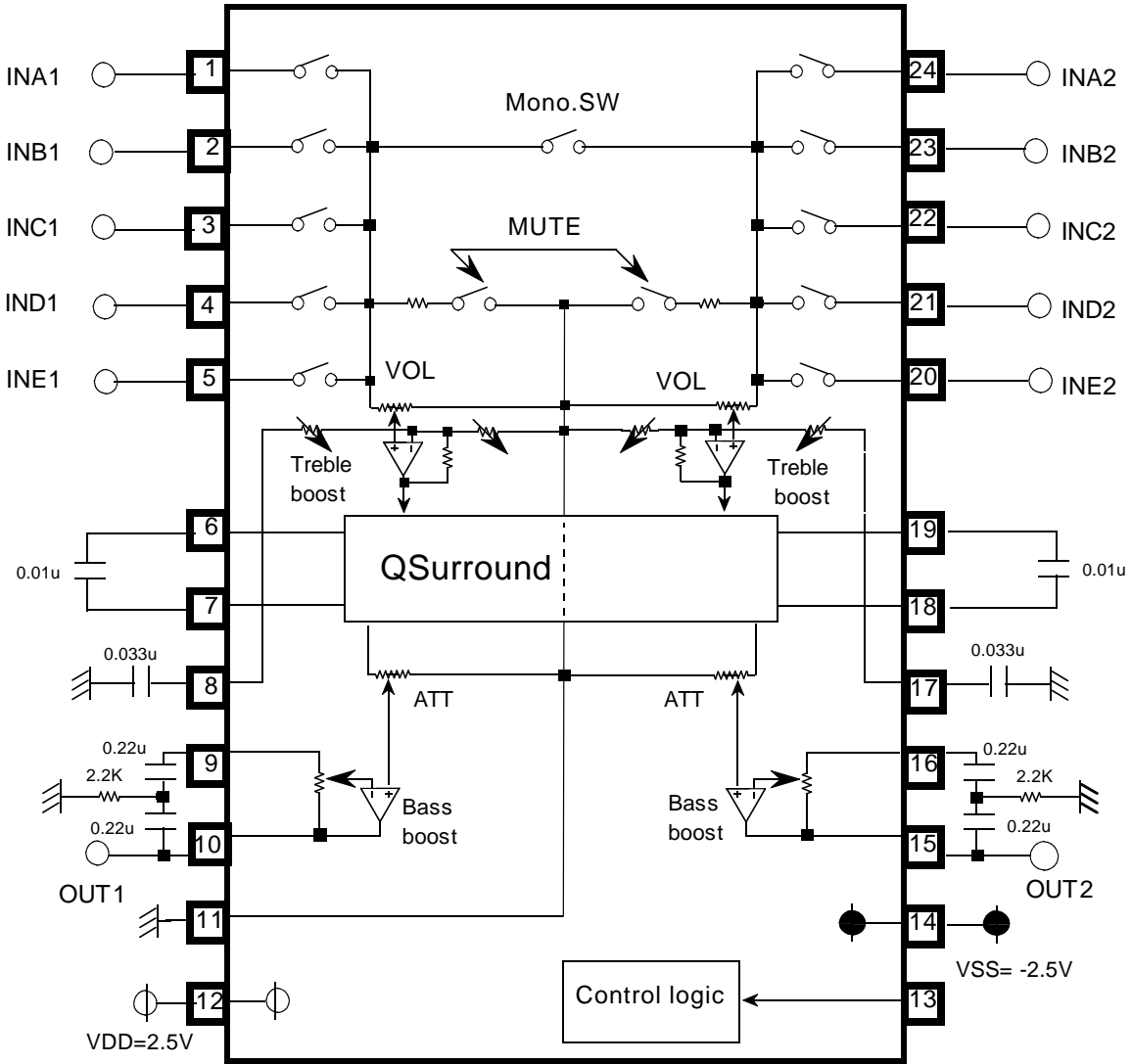

Units Resistor :  $\Omega$   
 Capacitor: F

# PRELIMINARY

# M61515FP

Notice : This is not a final specification.  
some parametric limits are subject to change.

## TONE CONTROL/VOLUME CONTROL

### OUTLINE

