

High Endurance CMOS 192 bit EEPROM
With Secure Logic Access Control

BRIEF DATA

- Single 5 V Supply Voltage
- Programming Time: 5 ms
- Memory Divided Into:
 - 16 bits of Circuit Identification
 - 48 bits of Card Identification
 - 48 bits of Count Data
 - 16 bits of Certificate
 - 48 bits of Transport Code
 - 64 bits of Issuer Data
- Counting Capability up to 262,144 Units
- Circuit Protected by Transport Code for Delivery from ST to the Customer
- 5 External Contacts Only (ISO 7816 Compatible)
- Answer to Reset (Fully Compatible with ISO 7816-3)
- E.S.D. Protection Greater Than 4000 V
- Power-On and Low V_{CC} Reset
- 10 Years Data Retention
- 1 Million Erase/Write Cycles Endurance

DESCRIPTION

The ST1305 is a 192-bit EEPROM device with associated security logic to control memory access. The circuit includes counting capabilities and thus is very well adapted to prepaid card applications.

The ST1305 is protected by hard-wired security logic and special fuses. The memory is arranged as a matrix of 24x8 cells, accessed in a serial bit-wise fashion for reading and programming, and in a byte-wise fashion for internal erasing.

The device recognises three commands issued via the RST and CLK pins (as described in the full data sheet):

- RESET: to reset the internal address register to 00d
- READ: to increment the internal address register, and read the data bit at that address
- PROG: to program the bit at the current address.

Figure 1. Delivery Forms

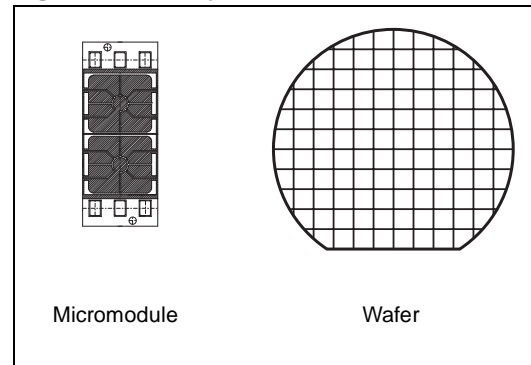

Figure 2. Pin Connection

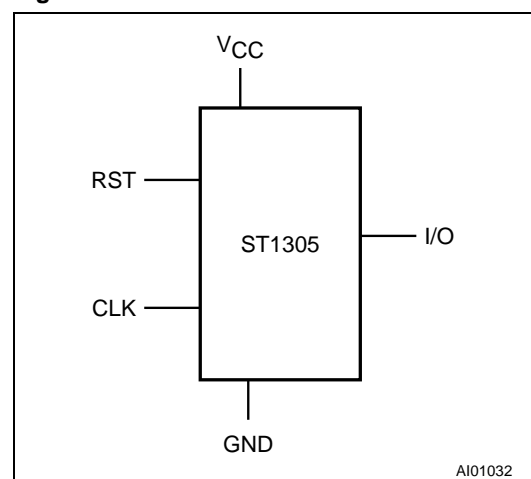

Table 1. Signal Names

CLK	Clock
RST	Reset
I/O	Serial Data Input/Output
V _{CC}	Supply Voltage
GND	Ground

ST1305

The device offers two distinct configurations:

- ISSUER: for the card manufacturer, allowing special data to be written to the chip, during initialisation
- USER: for the end user of the card, restricting access to the chip.

Before delivery, from ST to the card issuer, the device is placed in the ISSUER configuration. This operation is performed by blowing the “test fuse”.

Figure 3. Memory Map

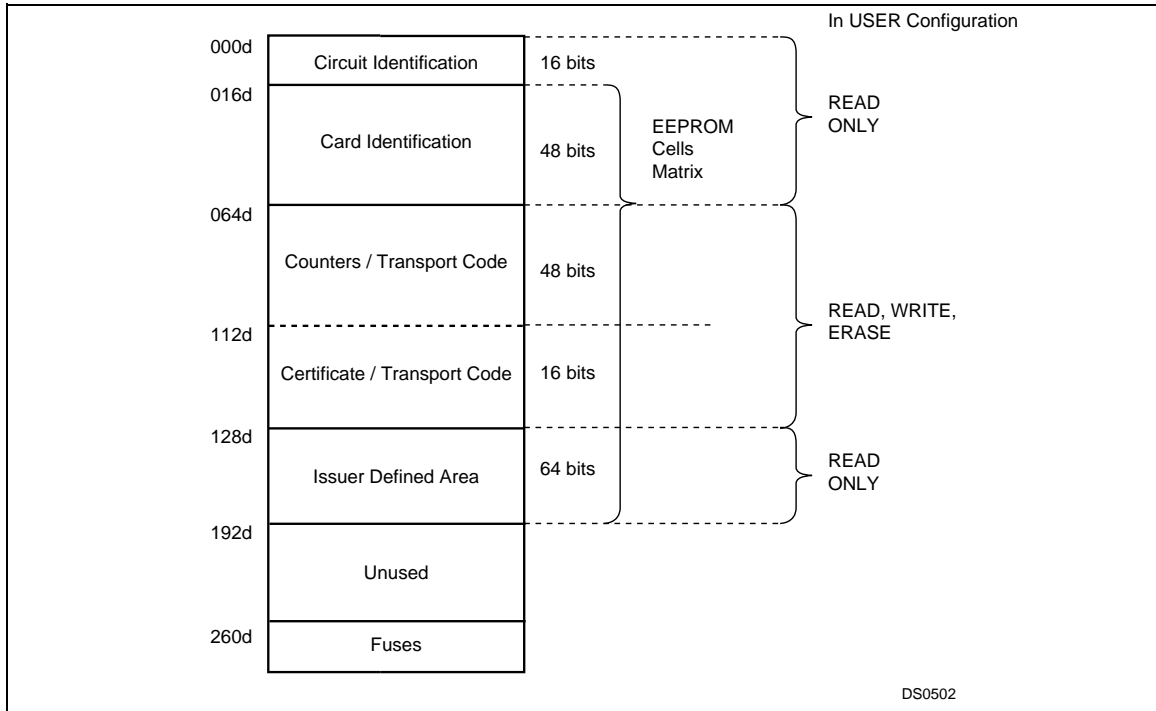

ORDERING INFORMATION SCHEME

For a full list of the available options, please see the current Memory Shortform Catalogue.

For further information on any aspect of this device, please contact your nearest ST Sales Office.

Example:

ST1305 - W2 / XX YY

DS0501

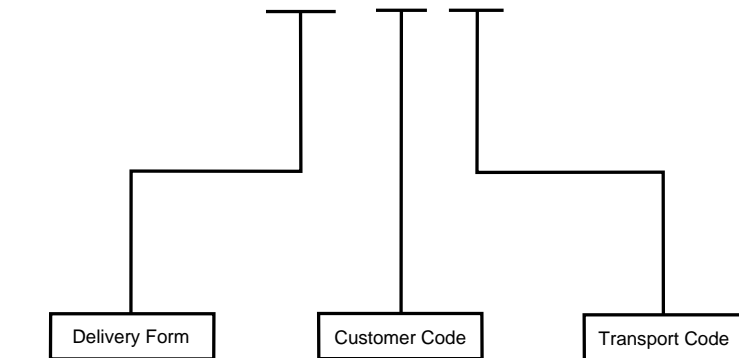

U: Micromodule on reel
W2: Wafer 280 µm thickness

Given by ST