

ST1153A

Version : A.05
Issue Date : 2003/03/18
File Name : ST1153A_A05.doc
Total Pages : 7

Low-saturation, Low-voltage
Bi-directional Multi-Channels Motor Driver



SILICON TOUCH TECHNOLOGY INC.
新竹市科學園區展業一路九號四樓之三
9-4F-3 Prosperity Road I Science-Based Industrial Park
Hsinchu, Taiwan 300, R.O.C.
Tel : 886-3-5645656 Fax : 886-3-5645626

ST1153A

Low-saturation, Low-voltage Bi-directional Multi-channels Motor Driver

General Specifications

The device is a multi-channels low-saturation bi-directional motor driver IC. This IC supports the maximum of 3 channel motor operating and supports control of forward, reverse, standby and braking operation for each motor. The design is optimal for stepper-motor applications, such as cameras, printers, FDDs, or other portable devices

Features and Benefits

- Low voltage operation ($V_{DD\ min} = V_{S1\ min} = V_{S2\ min} = 1.5V$)
- Low saturation voltage (Upper transistor + low transistor residual voltage; 0.3V typ. at 400mA)
- Maximal 3 channel bi-directional drivers
- Low input current drain
- Low current drain in standby mode
- Separate control logic power supply and motor driver power supply
- Brake function
- High output sinking and driving capability
- Thin, highly reliable package (SOP-14)

Pin Assignment

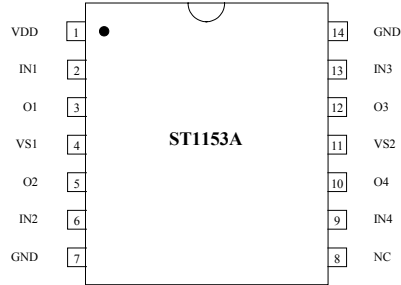

PIN NO.	PIN NAME	DESCRIPTION
1	VDD	Power supply pin for controller.
2	IN1	Input pin that determines driving mode.
3	O1	Output sinking / driving pin.
4	VS1	Power supply pin for output driver O1/ O2.
5	O2	Output sinking / driving pin.
6	IN2	Input pin that determines driving mode.
7	GND	Ground pin
8	NC	No connecting
9	IN4	Input pin that determines driving mode.
10	O4	Output sinking / driving pin.
11	VS2	Power supply pin for output driver O3/ O4.
12	O3	Output sinking / driving pin.
13	IN3	Input pin that determines driving mode.
14	GND	Ground pin

Absolute Maximum Ratings (Unless otherwise noted, $T_A = 25^\circ\text{C}$)

Characteristic	Symbol	Rating	Unit
Supply Voltage	V_{DD}	5.5	V
	V_S	3.5	V
Input Voltage	V_{IN}	$V_{DD}+0.4$	V
GND pin Current	I_{GND}	1.5	A
I_{ODC} Current (per connection)	I_{ODC}	0.75	A
Power Dissipation	P_D	800	mW
Operating Temperature Range	T_{OPR}	-40 ~ 125	$^\circ\text{C}$
Storage Temperature Range	T_{STG}	-65 ~ 150	$^\circ\text{C}$

Electrical Characteristic

(Unless otherwise noted, $T_A = 25^\circ\text{C}$ & $V_{DD} = V_S = 3V$)

Characteristic	Sym.	Condition	Limit			Unit
			Min.	Typ.	Max.	
Supply Voltage	V_{DD}		1.5	3	5.5	V
	V_S		1.5	3	3.5	V
Supply Current ($I_{DD} + I_S$)	I_{DD0}	$V_{IN1, IN2, IN3, IN4} = 0V$		0.1	10	μA
	I_{DD1}	$V_{IN1}=3V, V_{IN2, IN3, IN4}=0V$		0.1	2	mA
	I_{DD2}	$V_{IN1, IN2}=3V, V_{IN3, IN4}=0V$		0.5	10	μA
IN1 / IN2 / IN3 / IN4 Input Terminal ($T_J = 25^\circ\text{C}$)						
Input Voltage "H"	V_{IH}	-	$0.8 \cdot V_{DD}$	-	$V_{DD}+0.4$	V
Input Voltage "L"	V_{IL}	-	-0.4	-	$0.2 \cdot V_{DD}$	V
Input Current "H"	I_{IH}	$V_{IN} = V_{DD}$	-	-	± 5	μA
Input Current "L"	I_{IL}	$V_{IN} = 0V$	-	-	± 5	μA
O1 / O2 / O3 / O4 Output Terminal ($T_J = 25^\circ\text{C}$)						
Output Voltage (upper + lower)	V_{OUT1}	$I_{OUT} = 200\text{ mA}$	-	0.2	0.3	V
	V_{OUT2}	$I_{OUT} = 400\text{ mA}$	-	0.3	0.6	V
	V_{OUT3}	$I_{OUT} = 400\text{ mA}$ (parallel connection)	-	0.2	0.4	V
	V_{OUT4}	$I_{OUT} = 800\text{ mA}$ (parallel connection)	-	0.4	0.7	V
Output Sustaining Voltage	$V_{O(SUS)}$	$I_{OUT} = 400\text{ mA}$	-	-	V_S	V

Truth Table

Functions of each Motor

IN1	IN2	O1/O3 (O1)	O2 / O4 (O3)	Mode
H	L	H	L	Forward
L	H	L	H	Reverse
H	H	H	H	Brake
L	L	OFF	OFF	Standby

Selection of Motor

IN3	IN4	Motor Selection
H	H	Motor 1
H	L	Motor 2
L	H	Motor 3
L	L	Motor 1 & Motor 2 (parallel connection)

Block Diagram & Application Circuit

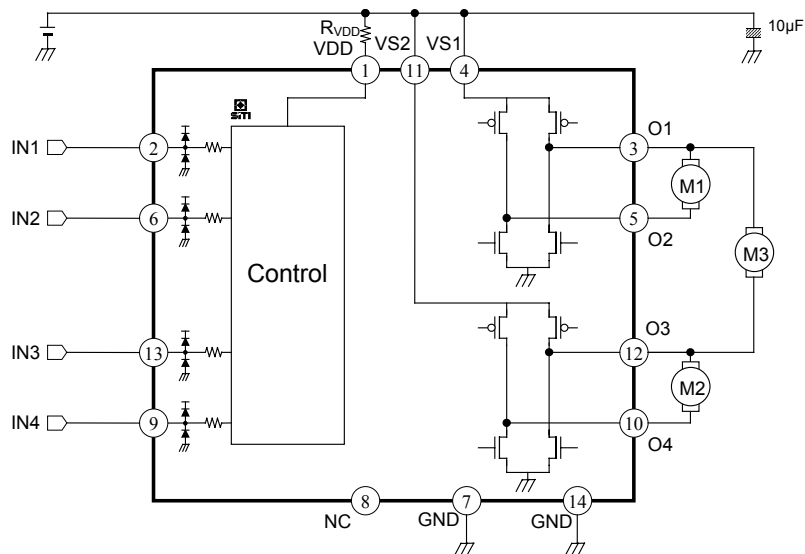

Application Notes

- To increase system stability, it is suggestion to connect a resistor R_{VDD} about 470Ω between battery power and driver's VDD pin as shown on application circuit.
- The IC supports 3 channels operating separately or the parallel connection of two channels. For 3th motor application, the power supply for 3th motor is from both VS1 and VS2 pins.
- In multiple power supply application, although power supply of control logic and motor driver are separated, the voltage of VDD pin must be larger than or equal to the voltage of VS1 and VS2 pin.
- The power dissipated by the IC varies widely with the supply voltage, the output current, and loading. It is important to ensure the application does not exceed the allowable power dissipation of the IC package. The recommended motor driver power dissipation versus temperature is depicted as follows:

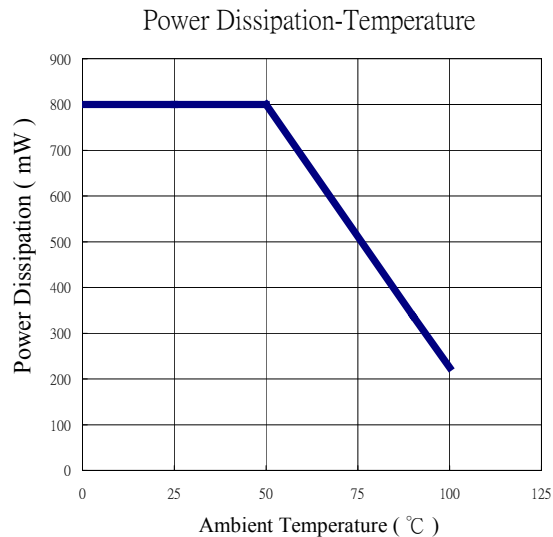

Package Specifications(SOP-14)

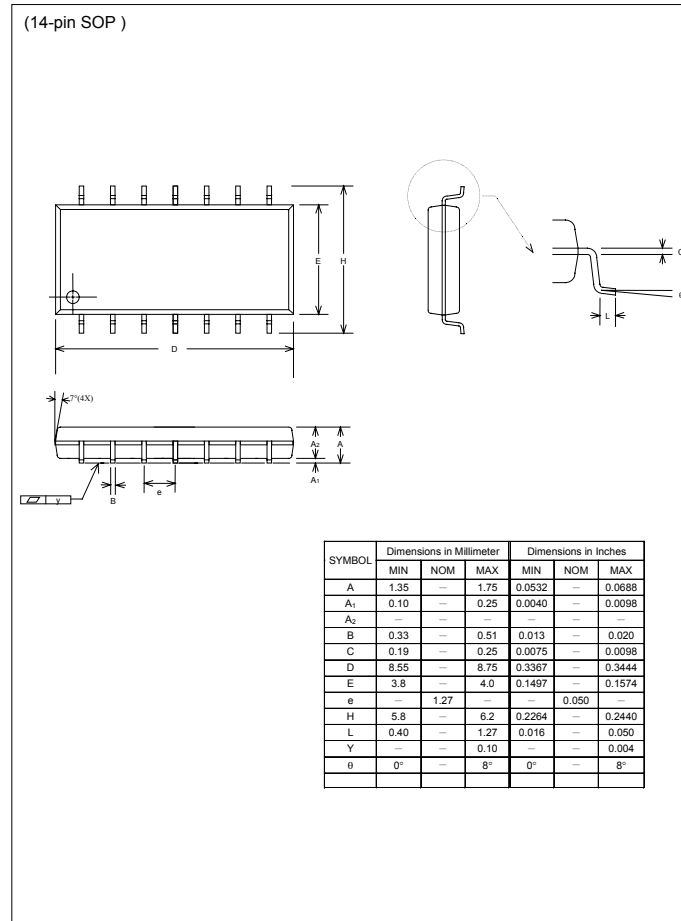

The products listed herein are designed for ordinary electronic applications, such as electrical appliances, audio-visual equipment, communications devices and so on. Hence, it is advisable that the devices should not be used in medical instruments, surgical implants, aerospace machinery, nuclear power control systems, disaster/crime-prevention equipment and the like. Misusing those products may directly or indirectly endanger human life, or cause injury and property loss.

Silicon Touch Technology, Inc. will not take any responsibilities regarding the misuse of the products mentioned above. Anyone who purchases any products described herein with the above-mentioned intention or with such misused applications should accept full responsibility and indemnify. Silicon Touch Technology, Inc. and its distributors and all their officers and employees shall defend jointly and severally against any and all claims and litigation and all damages, cost and expenses associated with such intention and manipulation.