

ST1114C / ST1114L / ST1114M

Version : A.008
Issue Date : 2003/09/26
File Name : SP-ST1114CLM-A.008.doc
Total Pages : 7

*Double Coil Brushless
DC Motor Predriver*



新竹市科學園區展業一路9號7樓之1
SILICON TOUCH TECHNOLOGY INC.
9-7F-1, Prosperity Road I, Science Based Industrial Park,
Hsin-Chu, Taiwan 300, R.O.C.
Tel : 886-3-5645656 Fax : 886-3-5645626

ST1114C / ST1114L / ST1114M

Double Coil Brushless

DC Motor Predriver

General Specifications

These pre-driver devices are designed specifically for electronic commutation of double coil DC motor applications. Each device is intended to be as an interface between a HALL IC and the drivers for larger double coil load. The main functions built-in devices are such as lock protection, automatic restart and frequency generating or rotation detecting output.

The output node “O1/O2” control the external drivers of double coil loads. The node “O1” turns on the output current when V(HIN) is logic low. Similarly, the node “O2” turns on the output current when V(HIN) is logic high.

Each device incorporates lock detection circuit to shut down the drivers. After the motor locking is released, the IC will turn on external drivers by automatic self-restart circuit. The device will shut down drivers roughly 1 to 3 seconds after the motor is locked and the automatic self-restart circuit will try to power up the drivers about 250ms per 1 to 3 seconds.

Pin Assignment

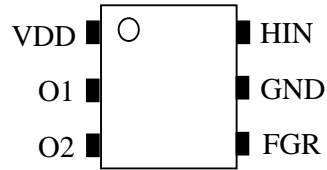

Pin NO.	Pin Name	Description
1	VDD	Power supply pin
2	O1	Output pin for driving power NPN
3	O2	Output pin for driving power NPN
4	FGR	Output pin of fan frequency (open-drain) FG : ST1114C (The frequency is same with the HIN frequency.) FG/2 : ST1114L (the frequency is the half HIN frequency.) RD : ST1114M (rotation detection)
5	GND	Ground pin
6	HIN	Input pin from Hall Latch IC

Features and Benefits

- Pre-driver for 2-phase, half-wave Brushless DC motor applications
- Suitable for 3V ~ 48V fan applications with less external components
- Wide operating voltage (1.8V ~16V)
- Lock detection and automatic self-restart
- Larger operating voltage range.
- FG output for ST1114C, FG/2 output for ST1114L, RD output for ST1114M
- Thin, highly reliable package (SOT-26)

Absolute Maximum Ratings ($T_A=25^{\circ}\text{C}$)

Parameter	Symbol	Rating	Unit
Supply Voltage	V_{DD}	1.8 ~ 16	V
Input Voltage	V_{IN}	-0.4 ~ $V_{DD}+0.4$	V
Output Current	I_{OMAX}	60	mA
Power Dissipation	P_D	0.35	W
Operating Temperature Range	T_A	-40 ~ 125	$^{\circ}\text{C}$
Storage Temperature Range	T_S	-65 ~ 150	$^{\circ}\text{C}$

Electrical Characteristic ($T_A = 25^{\circ}\text{C}$ & $V_{DD} = 12\text{V}$)

Characteristic	Sym.	Condition	Limit			Unit
			Min.	Typ.	Max.	
Supply Voltage	V_{DD}	Operating	1.8	12	16	V
Quiescent Current	I_{DD}	No load, All Inputs = 0V or V_{DD}	-	2.5	10	mA
HIN Input Terminal						
Input Voltage "H"	V_{IH}	-	$0.8 \cdot V_{DD}$	-	V_{DD}	V
Input Voltage "L"	V_{IL}	-	-0.4	-	$0.2 \cdot V_{DD}$	V
Input Current "H"	I_{IH}	$V_{IN} = V_{DD}$	-	-	± 1	μA
Input Current "L"	I_{IL}	$V_{IN} = 0\text{V}$	-	0.5	2	mA
O1/O2 Output Terminal						
Output Voltage High	V_{OH}	$I_{OUT} = 30\text{mA}$	11	11.5	-	V
Output Current	I_{OUT}	$V_{OUT} = 11\text{V}$	30	60	-	mA
FGR Open-Drain Terminal						
Output Leakage Current	I_{Leak}	$V_{FGR} = 12\text{V}$	-	1	5	μA
Output Current	I_{FGR}	$V_{FGROL} = 0.4\text{V}$	5	10	-	mA
Output Voltage High	V_{FGROH}	-	-	-	15	V
Output Voltage Low	V_{FGROL}	$I_{FGR} = 5\text{mA}$	-	0.15	0.4	V
Automatic Self-Restart Circuit						
On Period	T_{ON}	-	100	250	400	ms
Duty Ratio	R_{DR}	T_{OFF} / T_{ON}	6	7	8	

Truth Table

HIN	O1	O2
H	OFF	ON
L	ON	OFF

Block Diagram & Application Circuit

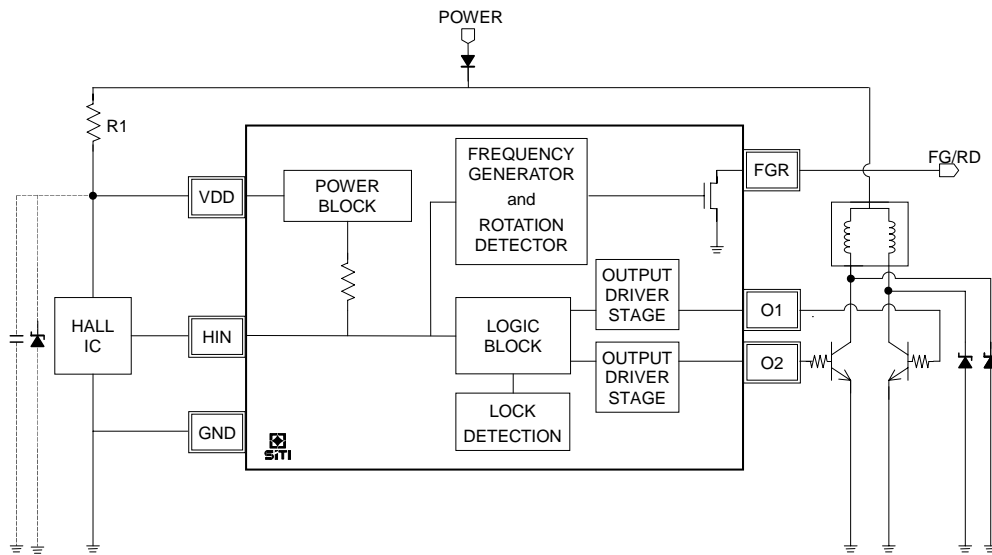

Application Notes

- The FGR pin is an open-drained output and outputs the same frequency with HIN pin for ST1114C, the half frequency of HIN pin for ST1114L, and rotation detection result for ST1114M. For the rotation detecting output application by ST1114M, the FGR pin, with a suitable external pull-up resistor, is at logical low state when fan is operating and logical high state when fan is stopped.
- The connection of the capacitance between VDD and GND will increase stability of operation.
- The connection of the resistor R1 between VDD and pre-driver will protect device under 12V operating. For 12V application, the recommended value of this resistor R1 is about 100Ω. For 24V or higher than 12V application, it is recommended that the operating voltage on IC must be under 12V. As shown on application circuit, it is recommended to connect about 0.5KΩ~1KΩ resistor R1 and 12Volts Zener Diode DZ between VDD and pre-driver and their values are dependent on fan applications.

Fan Application	Suggestion for R1	Zener Diode at IC VDD
5V	75Ω	-
12V	100Ω	-
Above 12V(24V,48V)	0.5KΩ~1KΩ	<12V

- The period of locking detection and automatic-restart are a little different at different operating voltage. In normal 12V applications, the lock detection time is about 250ms and auto-restart time is about 250ms per 2 seconds..
- The power dissipated by the IC varies widely with the supply voltage, the output current, and loading. It is important to ensure the application does not exceed the allowable power dissipation of the IC package. The recommended *motor driver* power dissipation versus temperature is depicted as follows:

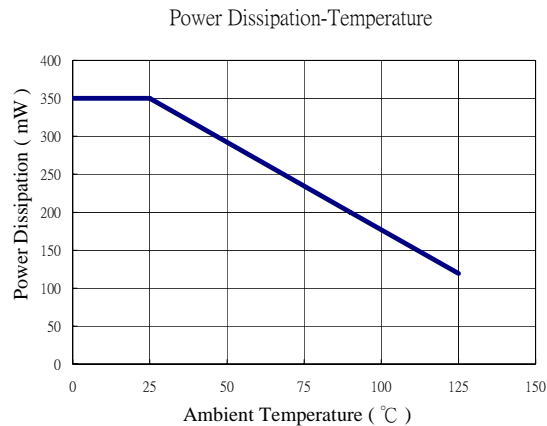

Package Specifications (SOT-26)

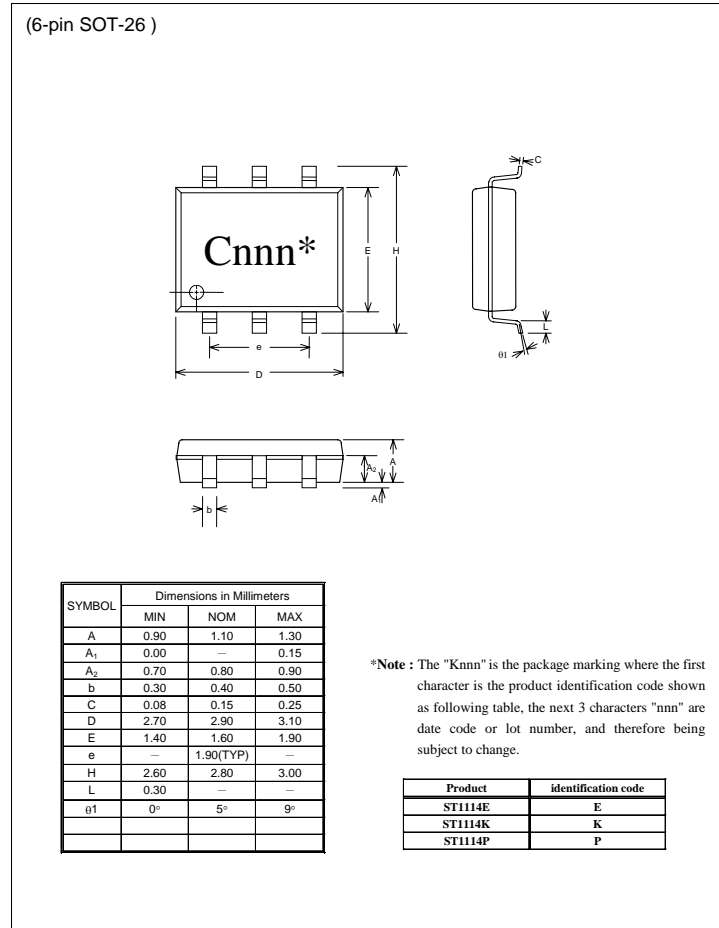

The products listed herein are designed for ordinary electronic applications, such as electrical appliances, audio-visual equipment, communications devices and so on. Hence, it is advisable that the devices should not be used in medical instruments, surgical implants, aerospace machinery, nuclear power control systems, disaster/crime-prevention equipment and the like. Misusing those products may directly or indirectly endanger human life, or cause injury and property loss.

Silicon Touch Technology, Inc. will not take any responsibilities regarding the misuse of the products mentioned above. Anyone who purchases any products described herein with the above-mentioned intention or with such misused applications should accept full responsibility and indemnify. Silicon Touch Technology, Inc. and its distributors and all their officers and employees shall defend jointly and severally against any and all claims and litigation and all damages, cost and expenses associated with such intention and manipulation.