

ST1111N

Version : A.004
Issue Date : 2002/07/18
File Name : SP-ST1111N-A.004.doc
Total Pages : 7

Single Coil Brushless DC Motor Drivers
(1.5 to 7.5 Volts)



新竹市科學園區展業一路9號7樓之1
SILICON TOUCH TECHNOLOGY INC.
9-7F-1, Prosperity Road I, Science Based Industrial Park,
Hsin-Chu, Taiwan 300, R.O.C.
Tel : 886-3-5645656 Fax : 886-3-5645626



ST1111N

Single Coil Brushless DC Motor Drivers (1.5 to 7.5 Volts)

General Specifications

The device is designed specifically for electronic commutation of single coil DC motor applications. They are intended to be used as an interface between HALL effect latch and a single coil load. Each device includes a power reverse protected diode, a fan tachometer for dividing the frequency of tachometer pulses from the driver with 2, a lock detection circuit to shut down the drivers for overheat prevention, and complementary bi-directional drivers for driving and sinking large load on a single silicon chip. Though the DC brushless motor driver can be started as low voltage as 1.5 Volt to 2 Volt and the device permits operation with supply voltage of 1.5 to 7.5 Volts, the design, specifications and performance have been optimized for 3V and 5V brushless DC motor applications.

The output driver node O1/O2 will be “turned to sink/drive” for V(HIN) = logic low. Similarly, the output O1/O2 will be “turned to drive/sink” for V(HIN) = logic high .

If the motor rotation is stalled by external force or obstacles, overdrive current (or lock current) may incur coil overheat/burning. To prevent coil overheat/burning, these devices incorporate lock detection circuit to shut down the drivers. After the motor locking is released, the drivers can be powered up using an automatic self-restart circuit. The drivers are shut down roughly 1 to 3 seconds after the motor is locked. After the drivers are shut down, the automatic self-restart circuit will try to power up the drivers every 1 to 3 seconds

Pin Description

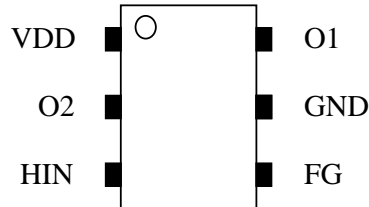

PIN NO.	PIN NAME	DESCRIPTION
1	VDD	Power supply pin
2	O2	Output sinking pin
3	HIN	Input pin from Hall Latch IC
4	FG	Output pin of fan tachometer (open-drain)
5	GND	Ground pin
6	O1	Output sinking pin

Features and Benefits

- ESD tolerance IC power outputs > 7,500 V
- ESD tolerance IC FG output > 4,500 V
- Optimized for single coil Brushless DC Motor applications
- Lock detection and automatic self-restart
- Tachometer output
- Built-in Reverse Protection
- High output sinking and driving capability
- Thin, highly reliable package (SOT-26)

Absolute Maximum Ratings (Unless otherwise noted, $T_A = 25\text{ }^\circ\text{C}$)

Characteristic	Symbol	Rating	Unit
Supply Voltage	V_{DD}	7.5	V
Input Voltage from a Hall Effect Latch Output	V_{IN}	$V_{DD}+0.4$	V
Output Current	I_{OUT}	400	mA
Output Current at Lock	I_{OL}	700	mA
Power Dissipation	P_D	350	mW
Operating Temperature Range	T_{OPR}	-40 ~ 125	$^\circ\text{C}$
Storage Temperature Range	T_{STG}	-65 ~ 150	$^\circ\text{C}$

Electrical Characteristics ($T_A = 25\text{ }^\circ\text{C}$, $V_{DD} = 5\text{V}$)

Characteristic	Sym.	Condition	Limit			Unit
			Min.	Typ.	Max.	
Supply Voltage	V_{DD}	Operating	1.5	5	7.5	V
Input Voltage "H"	V_{IH}	-	$0.8 \cdot V_{DD}$	-	$V_{DD}+0.4$	V
Input Voltage "L"	V_{IL}	-	-0.4	-	$0.2 \cdot V_{DD}$	V
Input Current "H"	I_{IH}	$V_{IN} = V_{DD}$	-	-	± 1	μA
Input Current "L"	I_{IL}	$V_{IN} = 0\text{V}$	-	-	± 5	mA
O1/O2 Output Terminal ($T_J = 25\text{ }^\circ\text{C}$)						
Output Voltage High	V_{OH}	$I_{OUT} = 300\text{ mA}$	4.4	-	-	V
Output Voltage Low	V_{OL}	$I_{OUT} = 300\text{ mA}$	-	-	0.6	V
Output Current	I_{OUT}	$R_L = 30\ \Omega$	-	148	-	mA
FG Open-Drain Terminal ($T_J = 25\text{ }^\circ\text{C}$)						
Output Leakage Current	I_{Leak}	$V_{FG} = 5\text{V}$	-	-	5	μA
Output Current	I_{FG}	$V_{FGOL} = 0.4\text{V}$	10	-	-	mA
Output Voltage Low	V_{FGOL}	$I_{FG} = 10\text{ mA}$	-	-	0.4	V
Automatic Self-Restart Circuit						
On Time	T_{ON}	-	-	215	-	ms
Duty Ratio	R_{DR}	T_{OFF} / T_{ON}	6	7	8	

Truth Table

HIN	O1	O2
H	H	L
L	L	H

Block Diagram & Application Circuit

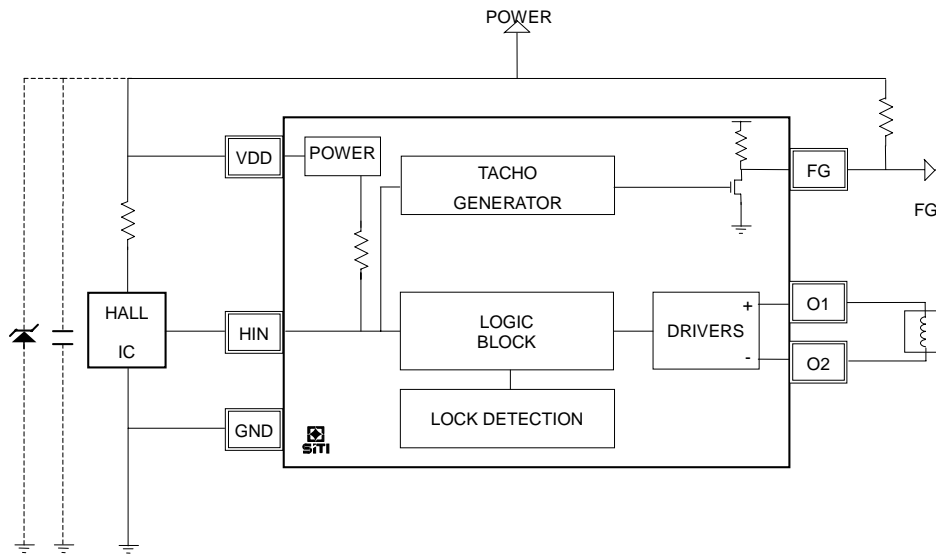

Application Notes

- There is no requirement of protection diode for power reverse fault in normal applications. The reverse protection function is built-in.
- The **FG** pin is an open-drained output dividing the frequency sensed by HALL IC with 2. With suitable output pull up, the fan tachometer output can be used directly with bipolar or MOS logic for motor speed monitoring/control.
- There is no requirement of the bypass capacitor or Zener Diode between VDD and GND in normal applications. The connection of this capacitor or Zener Diode between VDD and GND will increase stability of operation, if required.
- The power dissipated by the IC varies widely with the supply voltage, the output current, and loading. It is important to ensure the application does not exceed the allowable power dissipation of the IC package. The recommended motor driver power dissipation versus temperature is depicted as follows:

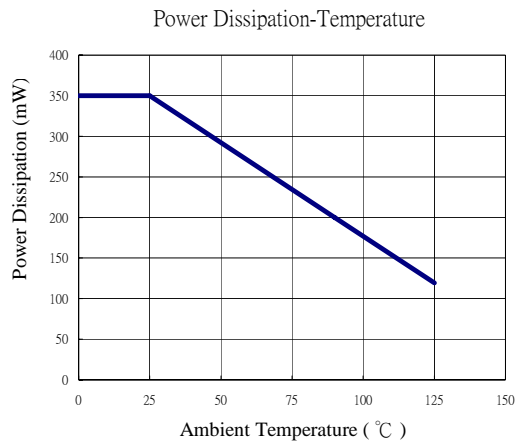

Package Specifications (SOT-26)

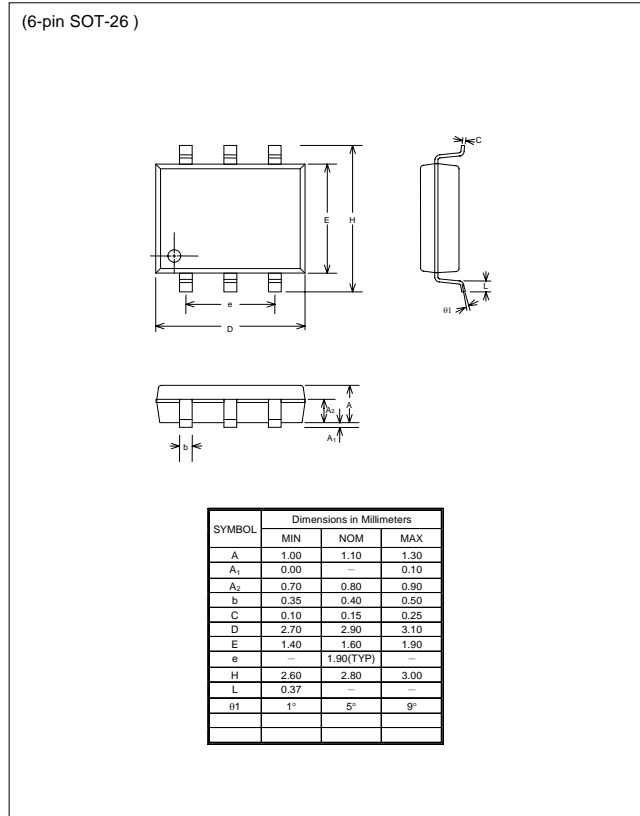

The products listed herein are designed for ordinary electronic applications, such as electrical appliances, audio-visual equipment, communications devices and so on. Hence, it is advisable that the devices should not be used in medical instruments, surgical implants, aerospace machinery, nuclear power control systems, disaster/crime-prevention equipment and the like. Misusing those products may directly or indirectly endanger human life, or cause injury and property loss.

Silicon Touch Technology, Inc. will not take any responsibilities regarding the misuse of the products mentioned above. Anyone who purchases any products described herein with the above-mentioned intention or with such misused applications should accept full responsibility and indemnify. Silicon Touch Technology, Inc. and its distributors and all their officers and employees shall defend jointly and severally against any and all claims and litigation and all damages, cost and expenses associated with such intention and manipulation.