

LOW DROPOUT VOLTAGE REGULATOR.

The KIA78DS05 series consists of positive fixed output voltage regulator IC capable of sourcing current up to 30mA. Due to the features of low dropout voltage and low standby current, these devices are useful for battery powered equipment.

This series includes current limiting, thermal shutdown, over voltage protection, input fault protection and excessive transient protection circuits internally.

- Low Standby Current of 500 μ A Typical.
- Maximum Output Current Up to 30mA.
- Low Dropout Voltage of Less than 0.3V.
- Multi-protection : Reverse Connection of Power Supply, 60V Load Dump, Thermal Shut Down and Current Limiting.

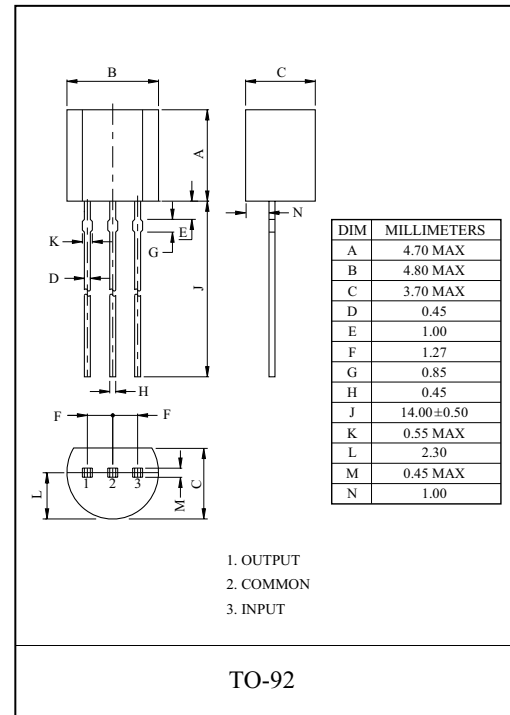

MAXIMUM RATINGS (Ta=25 $^{\circ}$ C)

| CHARACTERISTIC | | SYMBOL | RATING | UNIT |
|-------------------------|-----------------|-----------|-------------|--------------|
| Operating Input Voltage | | V_{IN} | 29 | V |
| Input Voltage of Surge | | V_{IN} | 60 | V |
| Power Dissipation | KIA78DS05BP/BPV | P_D | 600 | mW |
| | KIA78DS05BF | | 500 | |
| Operating Temperature | | T_{opr} | -40 ~ 85 | $^{\circ}$ C |
| Junction Temperature | | T_j | 150 | $^{\circ}$ C |
| Storage Temperature | | T_{stg} | -55 ~ 150 | $^{\circ}$ C |
| Soldering Temperature | | T_{SOL} | 260 (10sec) | $^{\circ}$ C |

Marking

| Type No. | Marking |
|-------------|---------|
| KIA78DS05BF | 8M |

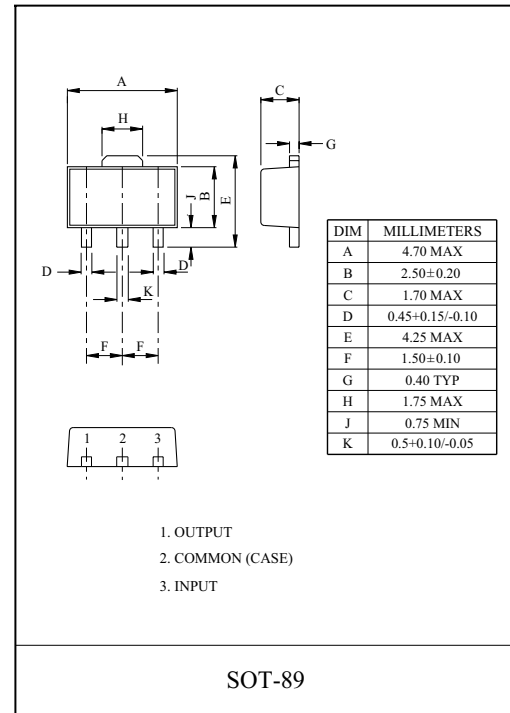

KIA78DS05BP/BPV/BF

BLOCK DIAGRAM

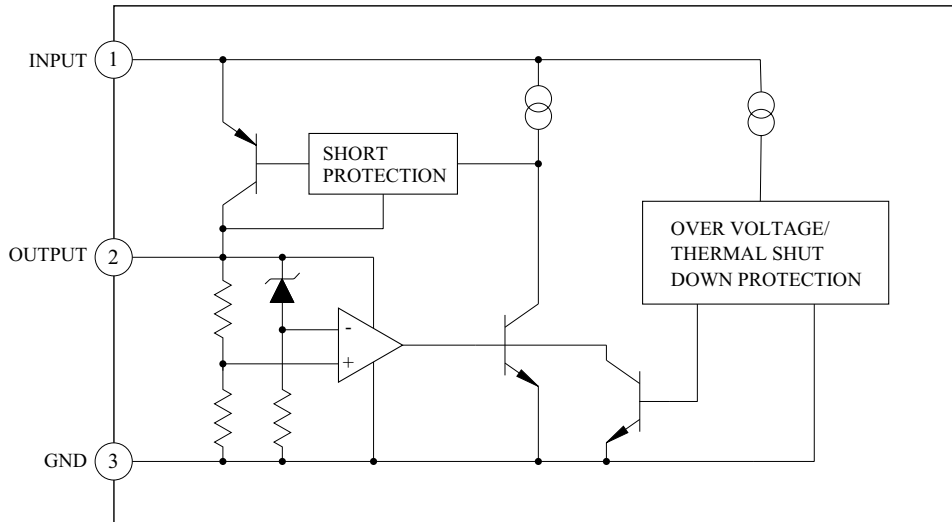

ELECTRICAL CHARACTERISTICS

(Unless otherwise specified, $V_{IN}=14V$, $I_{OUT}=5mA$, $C_{IN}=0.1\mu F$, $C_{OUT}=3.3\mu F$, $T_j=25^\circ C$)

| CHARACTERISTIC | SYMBOL | TEST CONDITION | KIA78DS05B ** | | | UNIT |
|------------------------|-----------|--|---------------|------|------|------|
| | | | MIN. | TYP. | MAX. | |
| Output Voltage | V_{OUT} | $5.35V \leq V_{IN} \leq 26V$ | 4.75 | 5.0 | 5.25 | V |
| | | $5.35V \leq V_{IN} \leq 26V, -40^\circ C \leq T_a \leq 85^\circ C$ | 4.5 | 5.0 | 5.5 | |
| Line Regulation | Reg-Line | $9.0V \leq V_{IN} \leq 16V$ | - | 1 | 10 | mV |
| | | $6.0V \leq V_{IN} \leq 26V$ | - | 4 | 30 | |
| Load Regulation | Reg-Load | $5.0mA \leq I_{OUT} \leq 30mA$ | - | 1 | 50 | mV |
| Quiescent Current | I_B | $I_{OUT}=0$ | - | 0.5 | 1 | mA |
| | | $6V \leq V_{IN} \leq 26V, I_{OUT}=5mA$ | - | 0.6 | 1 | |
| Dropout Voltage | V_D | $I_{OUT}=5mA$ | - | 0.1 | 0.2 | V |
| | | $I_{OUT}=10mA$ | - | 0.2 | 0.3 | |
| Max. Operating Voltage | V_{IN} | | 29 | 33 | - | V |

APPLICATION CIRCUIT

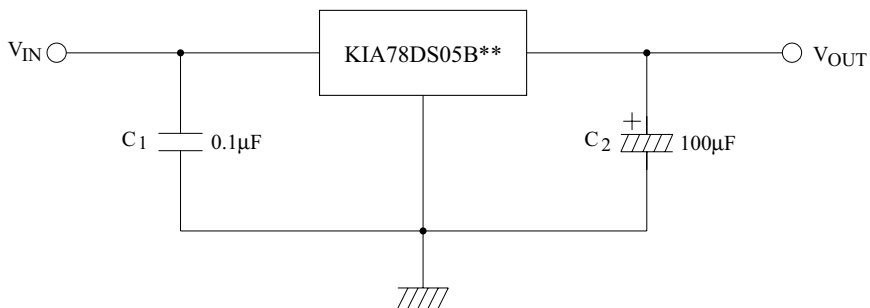

Capacitor C2 must be guaranteed to operate of the temperature range that the regulator should be operated correctly, 100µF is a suitable value to suppress the oscillation phenomenon at the output terminal.

KIA78DS05BP/BPV/BF

