

### THREE TERMINAL POSITIVE LOW DROPOUT VOLTAGE REGULATOR (5V, 6V, 8V, 9V, 10V, 12V, 15V)

The KIA78DL series are three-terminal regulators with maximum output current 250mA, packed in transistor size DPAK consuming low standby current, best suited as backup power supply for memory, etc. and power supply for medium size circuits.

This series is further provided with various protective functions.

#### FEATURES

- Low Standby Current Consumption : 500 $\mu$ A (Typ.).
- Maximum Output Current : 250mA (Max.).
- Less I/O Voltage Difference : 0.6V (Max).
- Multiple Protections : Power Reverse Connection/60V Load Dump/  
Thermal Protection/Short-Circuit Protection.
- Package is DPAK.

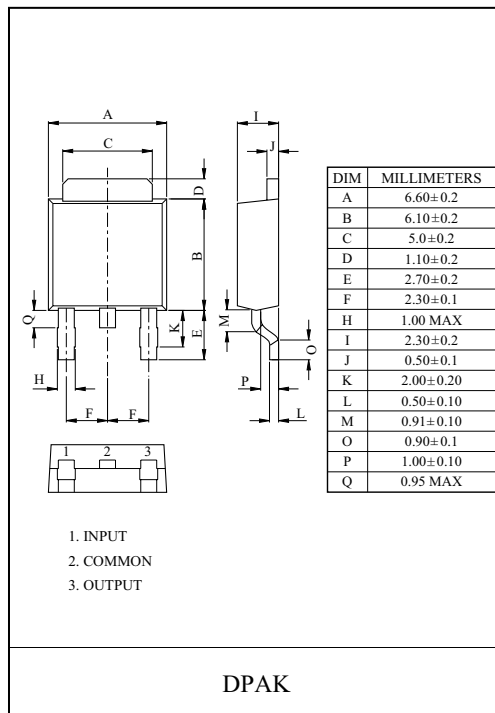

#### MAXIMUM RATINGS (Ta=25 °C)

CHARACTERISTIC	SYMBOL	RATING	UNIT
Operating Input Voltage	V <sub>IN</sub>	29	V
Input Voltage of Surge	V <sub>IN</sub>	60	V
Power Dissipation	Ta=25 °C	1.3	W
	Tc=25 °C	12	
Junction Temperature	T <sub>j</sub>	-40~150	°C
Operating Temperature	T <sub>opr</sub>	-40~85	°C
Storage Temperature	T <sub>stg</sub>	-55~150	°C
Lead Temperature Time	T <sub>sol</sub>	260 (10sec)	°C

#### BLOCK DIAGRAM

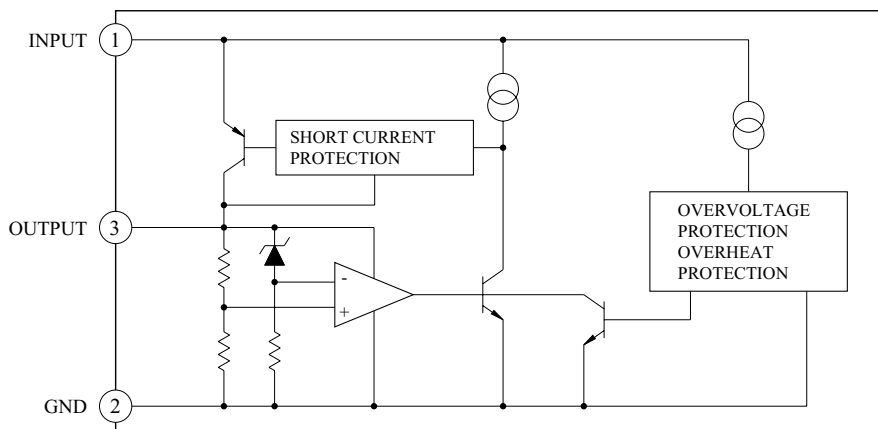

# KIA78DL05F~78DL15F

## KIA78DL05F

ELECTRICAL CHARACTERISTICS ( $V_{IN}=14V$ ,  $I_{OUT}=10mA$ ,  $T_j=25^\circ C$ )

CHARACTERISTIC	SYMBOL	TEST CIRCUIT	TEST CONDITION	MIN.	TYP.	MAX.	UNIT
Output Voltage	$V_{OUT}$	-	$V_{IN}=5.35\sim 26V$ , $T_a=-40\sim 85^\circ C$	4.5	5	5.5	V
Line Regulation	$\Delta V_{OUT(1)}$	-	$V_{IN}=9\sim 16V$	-	2	10	mV
			$V_{IN}=6\sim 26V$	-	4	30	
Load Regulation	$\Delta V_{OUT(2)}$	-	$I_{OUT}=10\sim 200mA$	-	14	50	mV
Quiescent Current	$I_{CC}$	-	$I_{OUT}\leq 10mA$ , $V_{IN}=6\sim 26V$	-	0.5	1	mA
Dropout Voltage	$V_{DROP}$	-	$I_{OUT}=50mA$	-	0.15	0.3	V
			$I_{OUT}=200mA$	-	0.4	0.6	
Max. Operating Input Voltage	$V_{IN}$	-		29	33	-	V

## KIA78DL06F

ELECTRICAL CHARACTERISTICS ( $V_{IN}=14V$ ,  $I_{OUT}=10mA$ ,  $T_j=25^\circ C$ )

CHARACTERISTIC	SYMBOL	TEST CIRCUIT	TEST CONDITION	MIN.	TYP.	MAX.	UNIT
Output Voltage	$V_{OUT}$	-	$V_{IN}=6.35\sim 26V$ , $T_a=-40\sim 85^\circ C$	5.4	6	6.6	V
Line Regulation	$\Delta V_{OUT(1)}$	-	$V_{IN}=10\sim 17V$	-	2	12	mV
			$V_{IN}=7\sim 26V$	-	5	36	
Load Regulation	$\Delta V_{OUT(2)}$	-	$I_{OUT}=10\sim 200mA$	-	17	60	mV
Quiescent Current	$I_{CC}$	-	$I_{OUT}\leq 10mA$ , $V_{IN}=7\sim 26V$	-	0.55	-	mA
Dropout Voltage	$V_{DROP}$	-	$I_{OUT}=50mA$	-	0.15	0.3	V
			$I_{OUT}=200mA$	-	0.4	0.6	
Max. Operating Input Voltage	$V_{IN}$	-		29	33	-	V

## KIA78DL08F

ELECTRICAL CHARACTERISTICS ( $V_{IN}=16V$ ,  $I_{OUT}=10mA$ ,  $T_j=25^\circ C$ )

CHARACTERISTIC	SYMBOL	TEST CIRCUIT	TEST CONDITION	MIN.	TYP.	MAX.	UNIT
Output Voltage	$V_{OUT}$	-	$8.35V\leq V_{IN}\leq 26V$ , $-40^\circ C\leq T_a\leq 85^\circ C$	7.2	8	8.8	V
Line Regulation	$\Delta V_{OUT(1)}$	-	$12V\leq V_{IN}\leq 19V$	-	3	16	mV
			$9V\leq V_{IN}\leq 26V$	-	6	45	
Load Regulation	$\Delta V_{OUT(2)}$	-	$10mA\leq I_{OUT}\leq 200mA$	-	22	80	mV
Quiescent Current	$I_{CC}$	-	$I_{OUT}\leq 10mA$ , $9V\leq V_{IN}\leq 26V$	-	0.6	-	mA
Dropout Voltage	$V_{DROP}$	-	$I_{OUT}=50mA$	-	0.15	0.3	V
			$I_{OUT}=200mA$	-	0.4	0.6	
Max. Operating Input Voltage	$V_{IN}$	-	-	29	33	-	V

# KIA78DL05F~78DL15F

## KIA78DL09F

ELECTRICAL CHARACTERISTICS ( $V_{IN}=16V$ ,  $I_{OUT}=10mA$ ,  $T_j=25^\circ C$ )

CHARACTERISTIC	SYMBOL	TEST CIRCUIT	TEST CONDITION	MIN.	TYP.	MAX.	UNIT
Output Voltage	$V_{OUT}$	-	$9.35V \leq V_{IN} \leq 26V$ , $-40^\circ C \leq Ta \leq 85^\circ C$	8.1	9	9.9	V
Line Regulation	$\Delta V_{OUT(1)}$	-	$13V \leq V_{IN} \leq 20V$	-	3	18	mV
			$10V \leq V_{IN} \leq 26V$	-	7	50	
Load Regulation	$\Delta V_{OUT(2)}$	-	$10mA \leq I_{OUT} \leq 200mA$	-	25	90	mV
Quiescent Current	$I_{CC}$	-	$I_{OUT} \leq 10mA$ , $10V \leq V_{IN} \leq 26V$	-	0.65	-	mA
Dropout Voltage	$V_{DROP}$	-	$I_{OUT}=50mA$	-	0.15	0.3	V
			$I_{OUT}=200mA$	-	0.4	0.6	
Max. Operating Input Voltage	$V_{IN}$	-	-	29	33	-	V

## KIA78DL10F

ELECTRICAL CHARACTERISTICS ( $V_{IN}=16V$ ,  $I_{OUT}=10mA$ ,  $T_j=25^\circ C$ )

CHARACTERISTIC	SYMBOL	TEST CIRCUIT	TEST CONDITION	MIN.	TYP.	MAX.	UNIT
Output Voltage	$V_{OUT}$	-	$10.35V \leq V_{IN} \leq 26V$ , $-40^\circ C \leq Ta \leq 85^\circ C$	9	10	11	V
Line Regulation	$\Delta V_{OUT(1)}$	-	$14V \leq V_{IN} \leq 21V$	-	4	20	mV
			$11V \leq V_{IN} \leq 26V$	-	8	60	
Load Regulation	$\Delta V_{OUT(2)}$	-	$10mA \leq I_{OUT} \leq 200mA$	-	28	100	mV
Quiescent Current	$I_{CC}$	-	$I_{OUT} \leq 10mA$ , $11V \leq V_{IN} \leq 26V$	-	0.7	-	mA
Dropout Voltage	$V_{DROP}$	-	$I_{OUT}=50mA$	-	0.15	0.3	V
			$I_{OUT}=200mA$	-	0.4	0.6	
Max. Operating Input Voltage	$V_{IN}$	-	-	29	33	-	V

## KIA78DL12F

ELECTRICAL CHARACTERISTICS ( $V_{IN}=18V$ ,  $I_{OUT}=10mA$ ,  $T_j=25^\circ C$ )

CHARACTERISTIC	SYMBOL	TEST CIRCUIT	TEST CONDITION	MIN.	TYP.	MAX.	UNIT
Output Voltage	$V_{OUT}$	-	$12.35V \leq V_{IN} \leq 26V$ , $-40^\circ C \leq Ta \leq 85^\circ C$	10.8	12	13.2	V
Line Regulation	$\Delta V_{OUT(1)}$	-	$16V \leq V_{IN} \leq 23V$	-	5	24	mV
			$13V \leq V_{IN} \leq 26V$	-	10	70	
Load Regulation	$\Delta V_{OUT(2)}$	-	$10mA \leq I_{OUT} \leq 200mA$	-	33	120	mV
Quiescent Current	$I_{CC}$	-	$I_{OUT} \leq 10mA$ , $13V \leq V_{IN} \leq 26V$	-	0.8	-	mA
Dropout Voltage	$V_{DROP}$	-	$I_{OUT}=50mA$	-	0.15	0.3	V
			$I_{OUT}=200mA$	-	0.4	0.6	
Max. Operating Input Voltage	$V_{IN}$	-	-	29	33	-	V

# KIA78DL05F~78DL15F

KIA78DL15F

ELECTRICAL CHARACTERISTICS ( $V_{IN}=20V$ ,  $I_{OUT}=10mA$ ,  $T_j=25^\circ C$ )

CHARACTERISTIC	SYMBOL	TEST CIRCUIT	TEST CONDITION	MIN.	TYP.	MAX.	UNIT
Output Voltage	$V_{OUT}$	-	$15.35V \leq V_{IN} \leq 26V$ , $-40^\circ C \leq T_a \leq 85^\circ C$	13.5	15	16.5	V
Line Regulation	$\Delta V_{OUT(1)}$	-	$19V \leq V_{IN} \leq 26V$	-	6	30	mV
			$16V \leq V_{IN} \leq 26V$	-	12	80	
Load Regulation	$\Delta V_{OUT(2)}$	-	$10mA \leq I_{OUT} \leq 200mA$	-	40	150	mV
Quiescent Current	$I_{CC}$	-	$I_{OUT} \leq 10mA$ , $16V \leq V_{IN} \leq 26V$	-	0.9	-	mA
Dropout Voltage	$V_{DROP}$	-	$I_{OUT}=50mA$	-	0.15	0.3	V
			$I_{OUT}=200mA$	-	0.4	0.6	
Max. Operating Input Voltage	$V_{IN}$	-	-	29	33	-	V

## TEST CIRCUIT

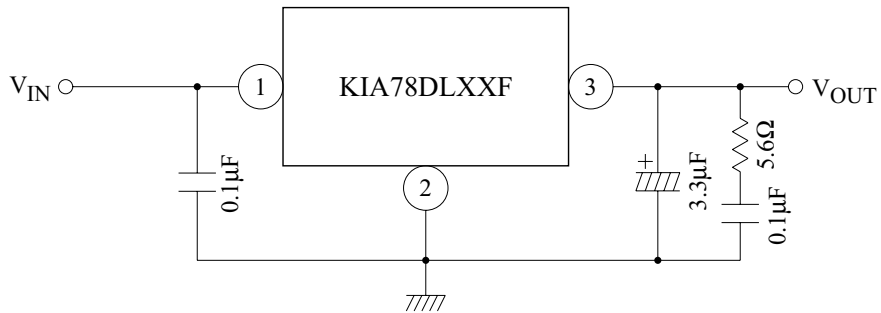

# KIA78DL05F~78DL15F

