

The PJ34063 Series is a monolithic control circuit containing the primary functions required for DC to DC converters. These devices consist of an internal duty cycle oscillator with an active current limit circuit, drive and a high current output switch. This series was specifically designed to be incorporated in step-up, step-down and voltage-inverting applications with a minimum number of external components. temperature compensated reference, comparator, controlled

FEATURES

- Operation from 3 to 40V input
- Low standby current
- Current limiting
- Output switch current to 1.5A
- Precision 2% reference
- Output - voltage adjustable
- Frequency of operation from 100Hz to 100KH

DIP-8

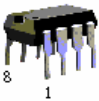

SOP-8



Pin : 1. Switch Collector 2. Switch Emitter
 3. Timing Capacitor 4. Gnd
 5. Comparator Inverting Input 6. Vcc
 7. IPK Sense 8. Driver Collector

ORDERING INFORMATION

Device	Operating temperature	Package
PJ34063CD	-20°C ~+85°C	DIP-8
PJ34063CS		SOP-8

BLOCK DIAGRAM

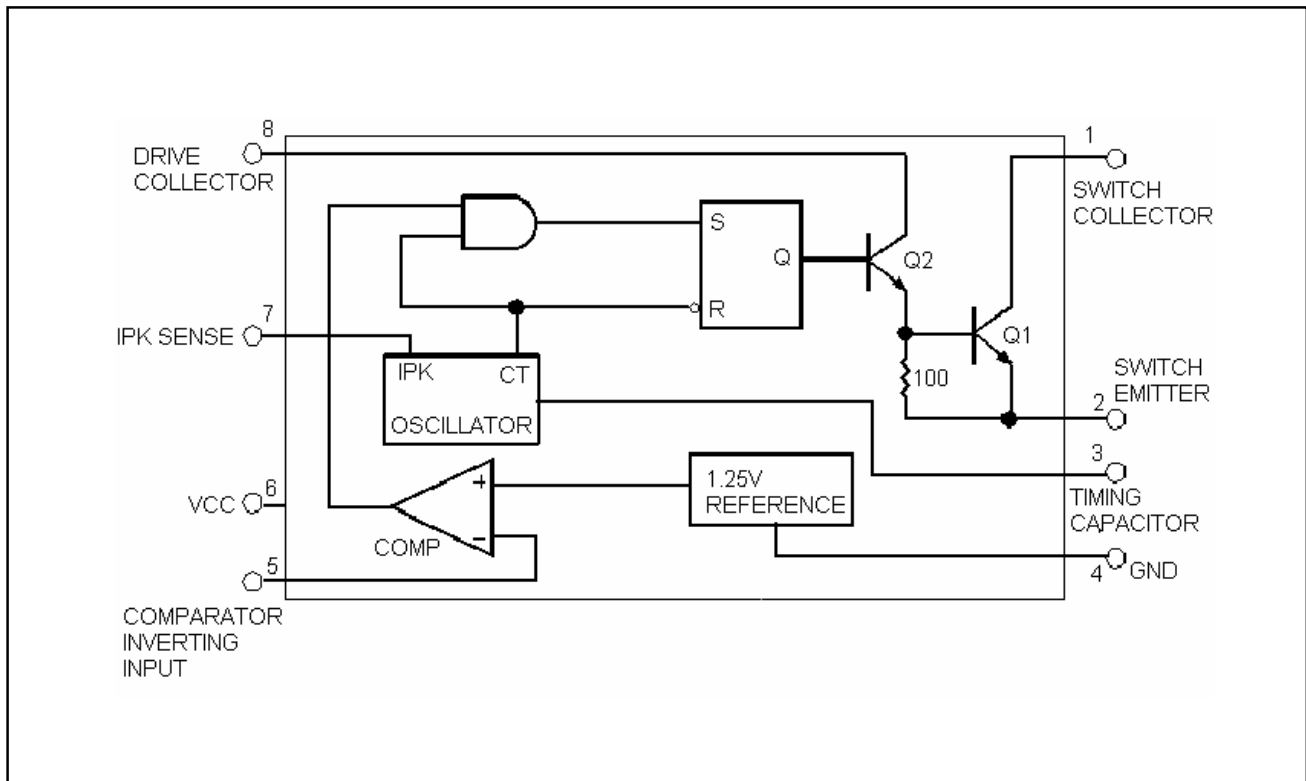

ABSOLUTE MAXIMUM RATINGS

Characteristic	Symbol	Value	Unit
Power Supply Voltage	V_{CC}	40	Vdc
Comparator Input Voltage Range	V_{IR}	-0.3 ~ +40	Vdc
Switch Collector Voltage	$V_{C(SW)}$	40	Vdc
Switch Emitter Voltage	$V_{E(SW)}$	40	Vdc
Switch Collector to Emitter Voltage	$V_{CE(SW)}$	40	Vdc
Driver Collector Voltage	$V_{C(drive)}$	40	Vdc
Drive Collector Current (Note 1)	$I_{C(drive)}$	100	mA
Switch Current	I_{sw}	1.5	A
Operating Junction Temperature	T_J	+150	°C
Operating Ambient Temperature Range	T_A	-20 to +85	°C
Storage Temperature Range	T_{stg}	-65 to +150	°C

ELECTRICAL CHARACTERISTICS

($V_{CC} = 5.0V$, $T_A = T_{low}$ to T_{high} , unless otherwise specified)

Characteristic	Symbol	Test Condition	Min	Typ	Max	Unit
----------------	--------	----------------	-----	-----	-----	------

OSCILLATOR

Frequency	f_{osc}	$V_{PINS}=0V, C_T=1.0nF, T_A=25^\circ C$	24	33	42	KHz
Charging Current	I_{chg}	$V_{CC}=5$ to 40V, $T_A=25^\circ C$	24	35	42	μA
Discharge Current	I_{dischg}	$V_{CC}=5$ to 40V, $T_A=25^\circ C$	140	220	260	μA
Discharge To Charge Current Ratio	I_{dischg}/I_{chg}	Pin7 to $V_{CC}, T_A=25^\circ C$	5.2	6.5	7.5	-
Current Limit Sense Voltage	$V_{IPK(sense)}$	$I_{chg} = I_{dischg}, T_A=25^\circ C$	250	300	350	mV

OUTPUT SWITCH(NOTE 2)

Saturation Voltage , Darlington Connection	$V_{CE(sat)}$	$I_{sw}=1.0A$, Pins1,8 connected	-	1.0	1.3	V
Saturation Voltage , Darlington Connection	$V_{CE(sat)}$	$I_{sw}=1.0A, R_{PIN8}=82 \Omega$ to V_{CC} , Forced $\beta \leq 20$	-	0.45	0.7	V
DC Current Gain	h_{FE}	$I_{sw}=1.0A, V_{CE} = 5.0V, T_A=25^\circ C$	50	75	-	-
Collector Off- State Current	$I_{C(off)}$	$V_{CE} =40V$	-	40	100	μA

COMPARATOR

Threshold Voltage	V_{TH}	$T_A=25^\circ C$	1.23	1.25	1.27	V
Threshold Voltage Line Regulation	Regline	$V_{CC} = 3$ to 40V		1.4	5.0	mV
Input Bias Current	I_{IB}	$V_{IN}=0V$		-20	-400	nA

TOTAL DEVICE

Supply Current	I_{CC}	$V_{CC}=5$ to 40V, $C_T=1.0nF$, Pin7= $V_{CC}, V_{PIN} > V_{th}$ Pin 2 =GND, remaining pins open	-	-	4.0	mA
----------------	----------	---	---	---	-----	----

Notes : 1.Maximum package power dissipation limits must be observed.

2.Low duty cycle pulse techniques are used during test to maintain junction temperature as close to ambient temperature as possible.

FIGURE 1.OUTPUT SWITCH ON-OFF TIME versus OSCILLATOR TIMING CAPACITOR

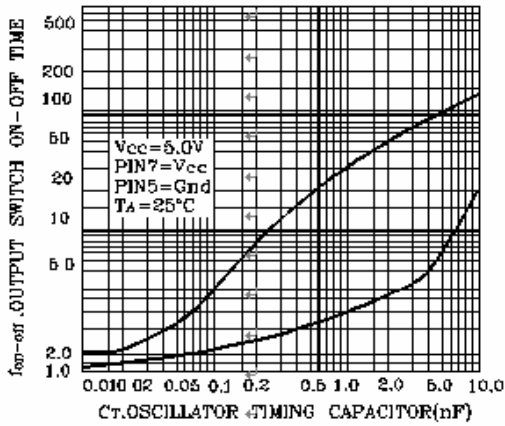

FIGURE 2.TIMING CAPACITOR WAVEFORM

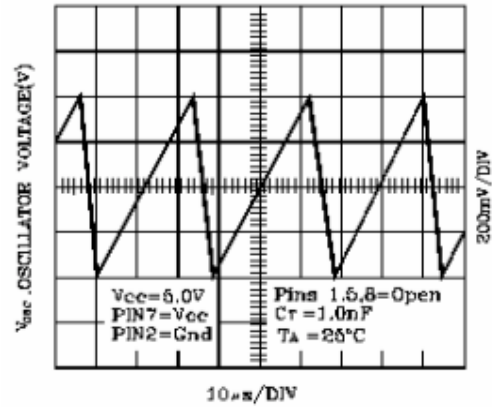

FIGURE 3.EMITTER FOLLOWER CONFIGURATION OUTPUT SATURATION VOLTAGE versus EMITTER CURRENT

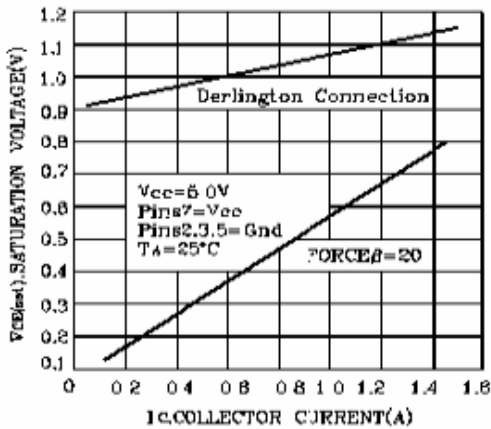

FIGURE 4.COMMON EMITTER CONFIGURATION OUTPUT SWITCH SATURATION VOLTAGE versus COLLECTOR CURRENT

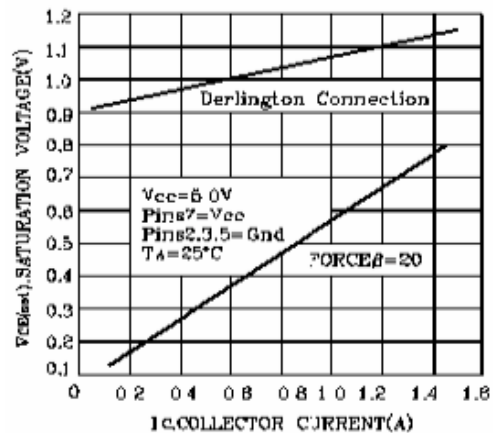

FIGURE 5.CURRENT LIMIT SENSE VOLTAGE versus TEMPERATURE

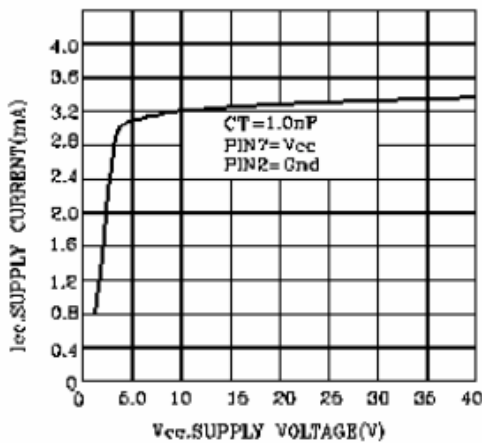

FIGURE 6.STANDBY SUPPLY CURRENT versus SUPPLY VOLTAGE

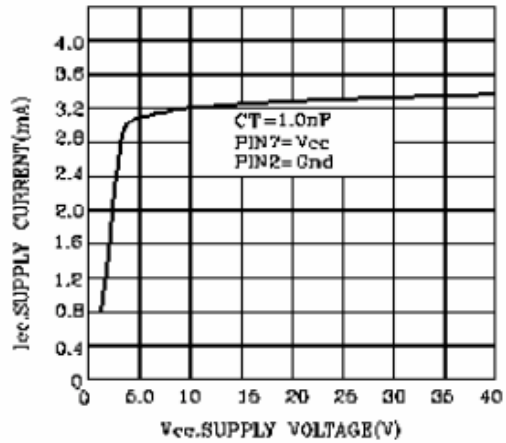

FIGURE 1.STEP-UP CONVERTER

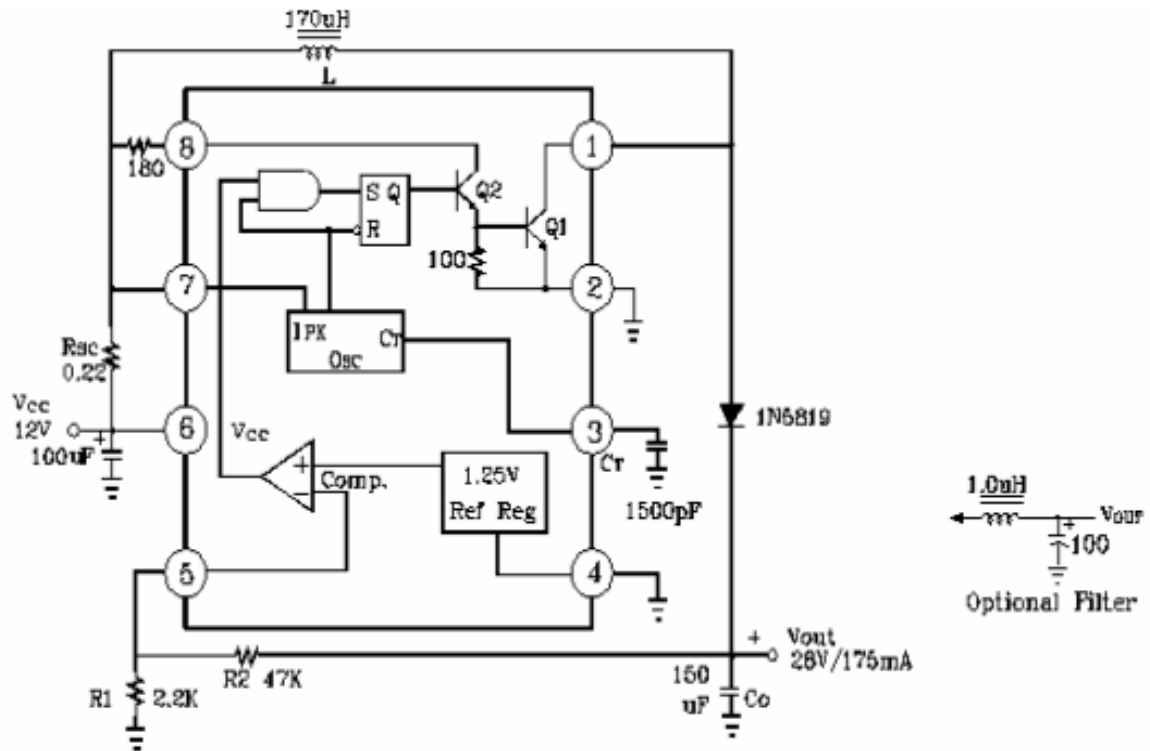
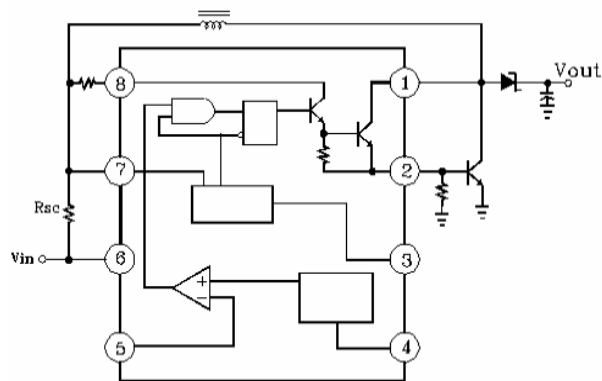
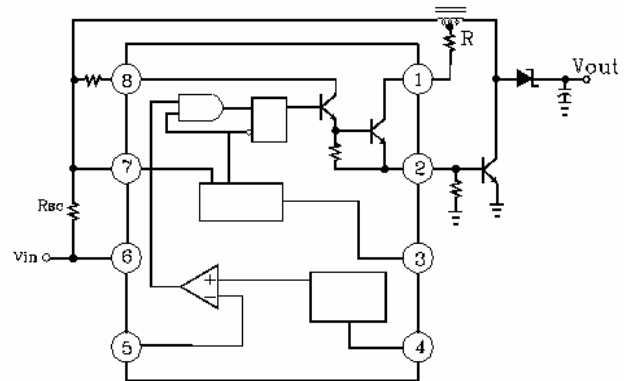

FIGURE 2.EXTERNAL CURRENT BOOST CONNECTIONS FOR Ic PEAK GREATER THAN 1.5A

2a.EXTERNAL NPN SWITCH



2b.EXTERNAL NPN SATURATED SWITCH



Note:R → 0 for constant Vin

FIGURE 3.STEP-DOWN CONVERTER

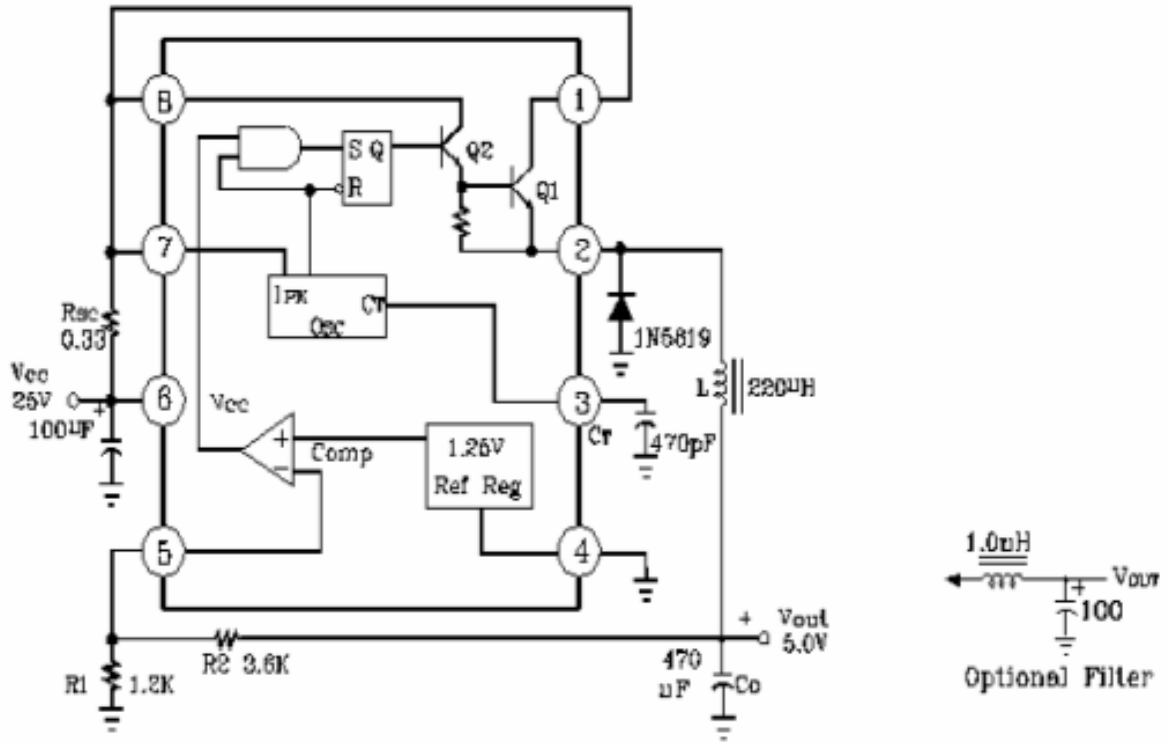

FIGURE 4.EXTERNAL CURRENT BOOST CONNECTIONS FOR Ic PEAK GREATER THAN 1.5A

4a.EXTERNAL NPN SWITCH

4b.EXTERNAL NPN SWITCH

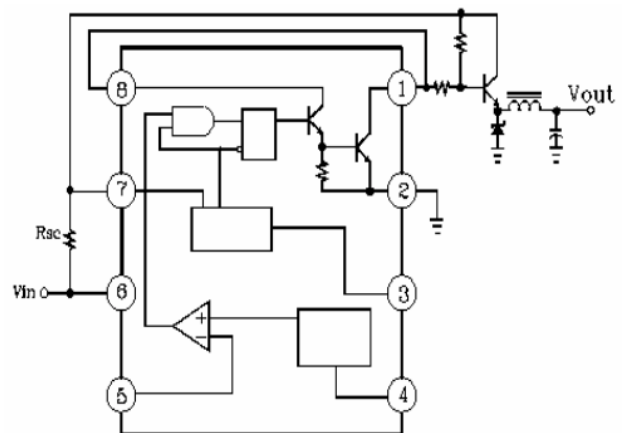
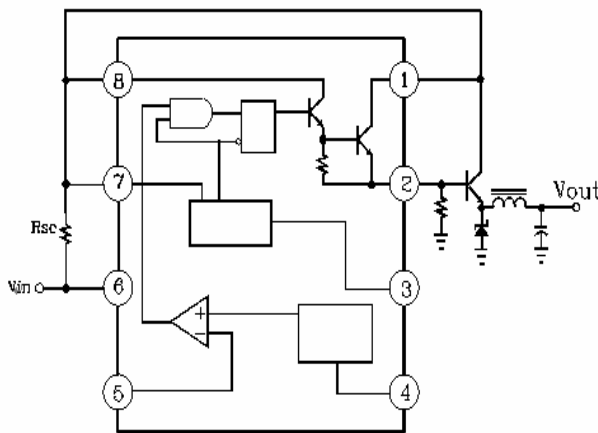

FIGURE 5.VOLTAGE INVERTING CONVERTER

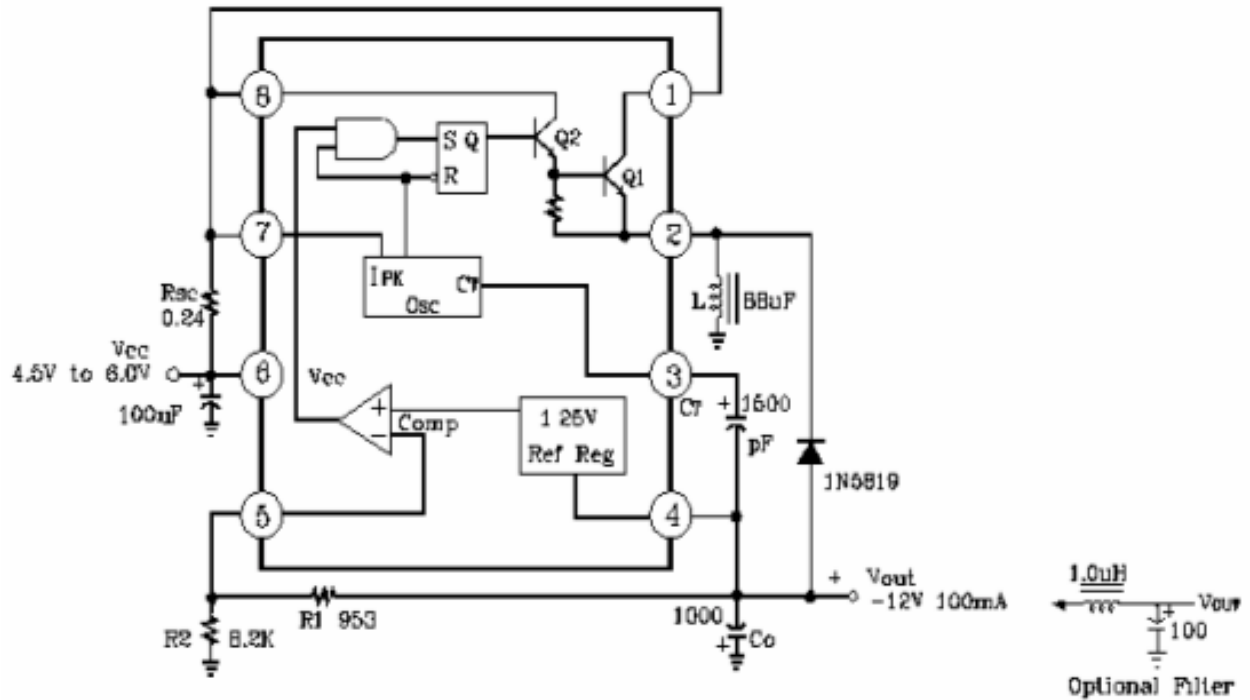

FIGURE 6.EXTERNAL CURRENT BOOST CONNECTIONS FOR Ic PEAK GREATER THAN 1.5A

6a.EXTERNAL NPN SWITCH

6b.EXTERNAL NPN SATURATED SWITCH

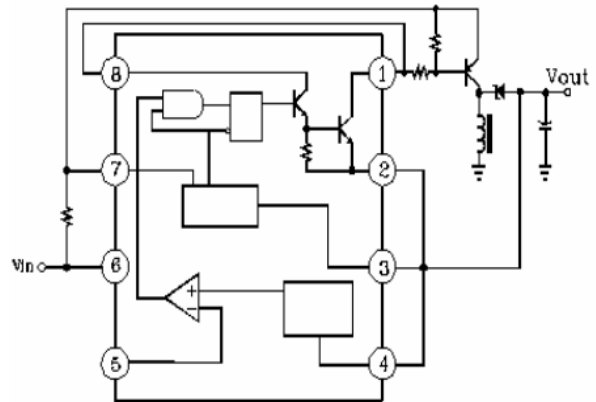
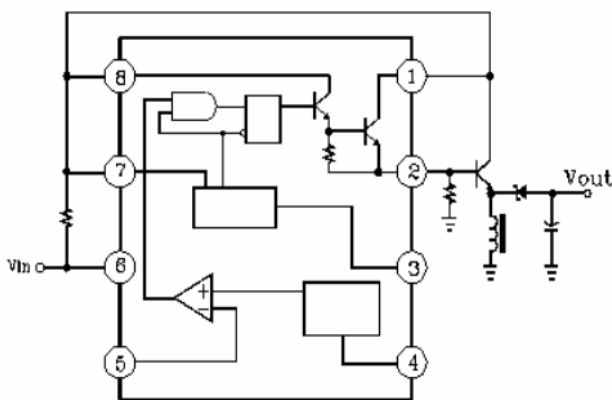

Table : Design Formula

Calculation	Step-Up	Step-Down	Voltage-Inverting
ton toff	$\frac{V_{out}+V_F-V_{in(min)}}{V_{CC(min)}-V_{sat}-V_{out}}$	$\frac{V_{OUT}+V_F}{V_{CC(min)}-V_{sat}-V_{out}}$	$\frac{ V_{out} +V_F}{V_{CC}+V_{sat}}$
(ton+toff) max	$\frac{1}{f \text{ min}}$	$\frac{1}{f \text{ min}}$	$\frac{1}{f \text{ min}}$
C _T	4.0×10 ⁻⁵ ton	4.0×10 ⁻⁵ ton	4.0×10 ⁻⁵ ton
I _{pk} (switch)	2I _{out} (max) $\left(\frac{ton}{toff} + 1 \right)$	2I _{out} (max)	2I _{out} (max) $\left(\frac{ton}{toff} + 1 \right)$
R _{sc}	0.3/I _{pk} (switch)	0.3/I _{pk} (switch)	0.3/I _{pk} (switch)
L (min)	$\left(\frac{V_{in(min)}-V_{sat}}{I_{pk}(switch)} \right) \cdot ton(max)$	$\left(\frac{V_{in(min)}-V_{sat}-V_{out}}{I_{pk}(switch)} \right) \cdot ton(max)$	$\left(\frac{V_{in(min)}-V_{sat}}{I_{pk}(switch)} \right) \cdot ton(max)$
Co	$\left(\frac{I_{outton}}{V_{ripple}(pp)} \right)$	$\left(\frac{I_{pk}(switch)(ton+toff)}{8V_{ripple}(pp)} \right)$	$\left(\frac{I_{outton}}{V_{ripple}(pp)} \right)$

TERMS AND DEFINITIONS

- ◆ V_{sat} = Saturation Voltage of the output switch.
- ◆ V_F = Forward Voltage drop of the rectifier.

The following power supply characteristics must be chosen:

- ◆ V_{in}= Normal input voltage
- ◆ V_{out}: Desied Output voltage, $|V_{out}|=1.25 \left(1+ \frac{R2}{R1} \right)$
- ◆ I_{out} : Desired output current.
- ◆ f_{min} : Minimum desired output switching frequency at the selected values for V_{in} and.I_o.
- ◆ V_{ripple(p-p)}: Desired peak-to-peak output ripple voltage. in practice, the calculated capaitor value will need to be increased due to its equivalent series resistance and board layout.

The ripple voltage should be kept to a low value since it will directly affect the line and load regulation.

DIP-8

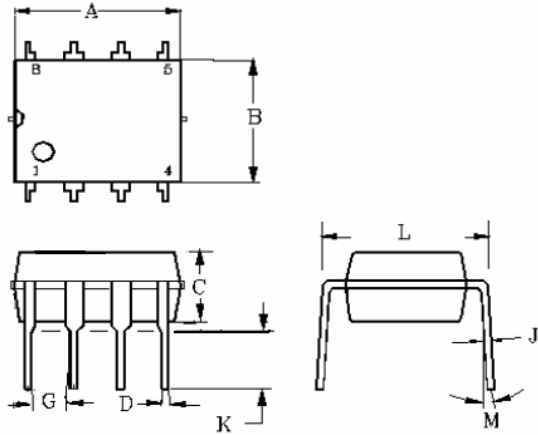

DIM	MILLIMETERS		INCHES	
	MIN	MAX	MIN	MAX
A	9.07	9.32	0.357	0.367
B	6.22	6.48	0.245	0.255
C	3.18	4.43	0.125	0.135
D	0.35	0.55	0.019	0.020
G	2.54BSC		0.10BSC	
J	0.29	0.31	0.011	0.012
K	3.25	3.35	0.128	0.132
L	7.75	8.00	0.305	0.315
M	-	10°	-	10°

SOP-8

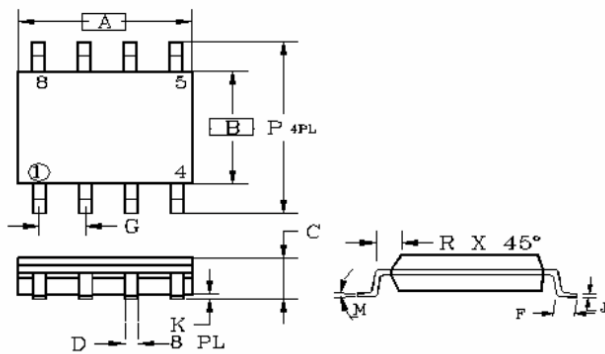

DIM	MILLIMETERS		INCHES	
	MIN	MAX	MIN	MAX
A	8.55	8.75	0.337	0.344
B	3.80	4.00	0.150	0.157
C	1.35	1.75	0.054	0.068
D	0.35	0.49	0.014	0.019
F	0.40	1.25	0.016	0.049
G	1.27BSC		0.05BSC	
K	0.10	0.25	0.004	0.009
M	0°	7°	0°	7°
P	5.80	6.20	0.229	0.244
R	0.25	0.50	0.010	0.019