

**STK732C****15 V Single Output MOS Chopper Regulator****Overview**

The STK732C is a chopper type step-down dedicated 15 V single output regulator that uses a power MOSFET as its switching element. The STK732C covers the 2 A and higher current regions, regions that are difficult to handle with three terminal step-down regulators. As compared with earlier chopper regulator products that used bipolar transistors, the efficiency of the STK732C has been further improved by the adoption of MOSFET technology, and use of the STK732C enables further miniaturization and increased performance in the end product since it corresponds to the adoption of a dedicated switching controller IC. Furthermore, due to the development of a unique MOS drive circuit, the STK732C can be used with a single power supply input. The STK732C can prove useful when standardizing and rationalizing power supply circuit design, since it can handle a wide range of power supply circuits in a number of applications, either as the secondary side regulator in a switching power supply or as the output regulator following AC transformer rectification.

Applications

- Power supplies in printers and other office equipment
- Power supplies in robots and other factory automation related equipment
- Power supplies in VCRs and other consumer products
- Secondary side regulators in switching power supplies

Features

- IMST substrate (insulated metal substrate technology)
- High efficiency realized by the adoption of MOSFET technology.
- An auxiliary drive power supply is no longer required due to the development of a unique NMOS FET drive circuit. This means that the STK732C can be used with a single power supply, thus allowing simplification of the input system.
- Built-in reverse going linear overload characteristic curve overcurrent protection circuit
- Ground line handling is eased even in multi-output power supply structures due to placement of the overcurrent detection resistor on the plus line.
- The STK732C's separate excitation oscillator structure provides high stability in the switching frequency.
- A built-in cutoff function allows an external signal to switch the output on and off.
- The STK732C's switching operating frequency is set at 85 kHz, which minimizes beating when used in a multiple output structure with STK730 type (5 V output, 125 kHz) products.

Package Dimensions

unit: mm

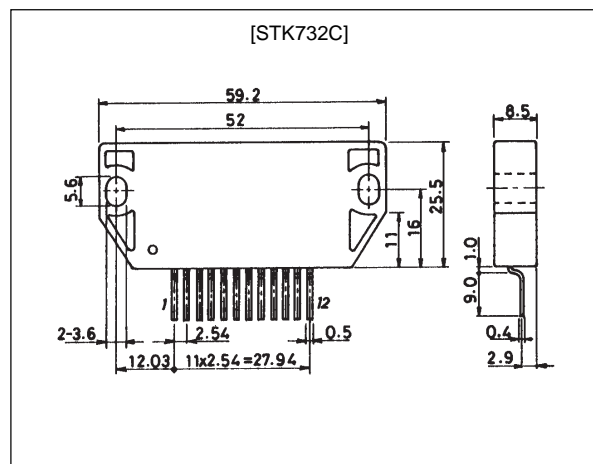
4137**SANYO Electric Co., Ltd. Semiconductor Business Headquarters**

TOKYO OFFICE Tokyo Bldg., 1-10, 1 Chome, Ueno, Taito-ku, TOKYO, 110 JAPAN

61096HA (OT)/82793YO (OT)No. 4533-1/6

Specifications

Maximum Ratings at $T_a = 25^\circ\text{C}$

Parameter	Symbol	Condition	Rating	Unit
Maximum DC input voltage	V_{IN} (DC) max		60	V
Maximum output current	I_O max		5/10 pk	A
Thermal resistance	θ_{j-c}		3.5	$^\circ\text{C}/\text{W}$
Junction temperature	T_j max		150	$^\circ\text{C}$
Operating substrate temperature	T_c max		105	$^\circ\text{C}$
Storage temperature	T_{stg}		-30 to +105	$^\circ\text{C}$

Electrical Characteristics at $T_a = 25^\circ\text{C}$, for the specified test circuit

Parameter	Symbol	Condition	Rating			Unit
			min	typ	max	
Output voltage setting	V_O	V_{IN} (DC) = 35 V, $I_O = 1$ A	14.7	15.0	15.3	V
Ripple voltage	V_{rp}	V_{IN} (DC) = 35 V, $I_O = 1$ A			25	mVrms
Input regulation	Reg-IN	V_{IN} (DC) = 20 to 45 V, $I_O = 1$ A			20	mV/V
Load regulation	Reg-L	V_{IN} (DC) = 35 V, $I_O = 0.5$ to 5 A			40	mV/A
Overcurrent protection start current	I_{OCP}	V_{IN} (DC) = 35 V	10			A
Efficiency	η	V_{IN} (DC) = 35 V, $I_O = 2.5$ A		90		%
Operating frequency	f	V_{IN} (DC) = 35 V, $I_O = 1$ A		85		kHz
Output voltage temperature coefficient	T_{CVO}	V_{IN} (DC) = 35 V, $I_O = 1$ A		0.01		$\%/^\circ\text{C}$
Cutoff voltage (Pin 12 input voltage)	V_{off}	Output on	3		20	V
		Output off	0		0.8	V

Peak Current

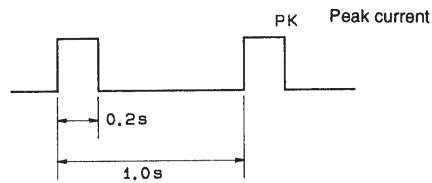

A01462

Block Diagram

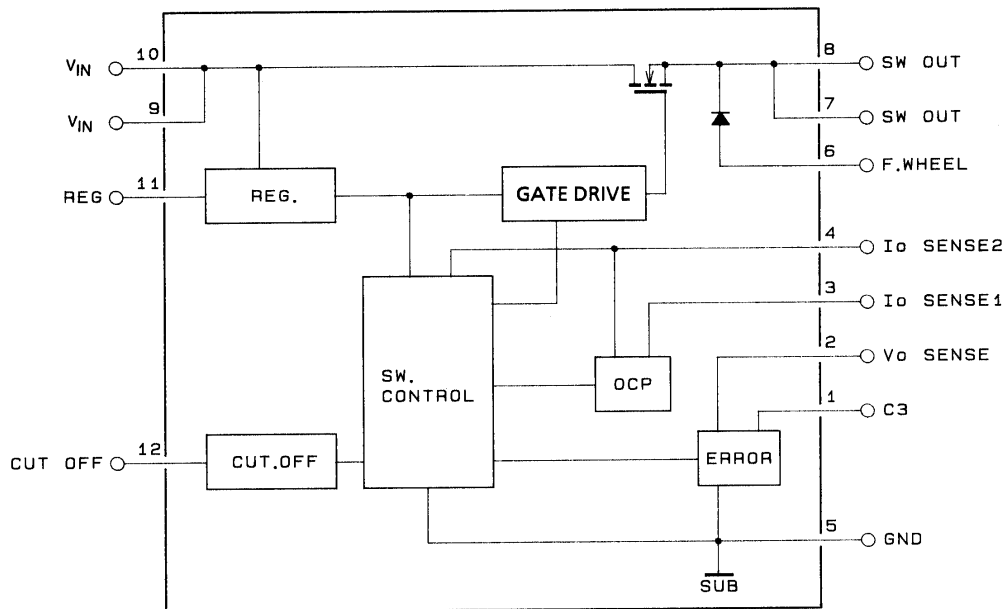

A01475

STK732C

Test Circuit

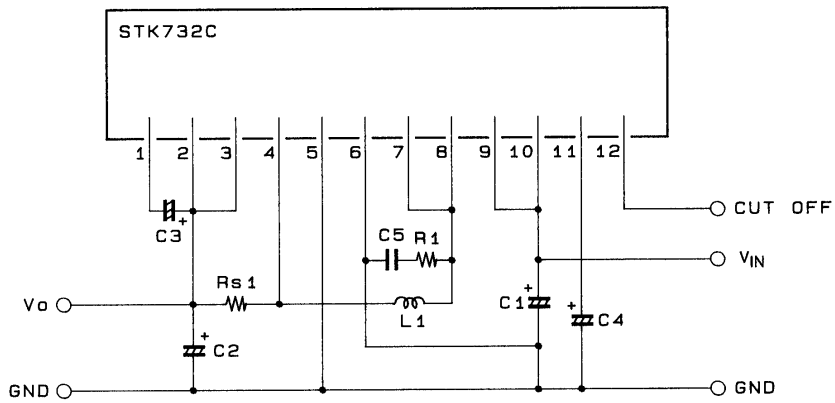

A01476

C1	220 μ F/63 V	L1	200 μ H (HP-054/TOKIN)
C2	1000 μ F/25 V	Rs1	0.05 Ω
C3	0.1 μ F/50 V	R1	10 Ω
C4	1 μ F/50 V		
C5	1000 pF		

Note: Since pin 5 is grounded to the substrate, the noise level and other characteristics may be adversely affected if the heat sink is connected to the FG or GND lines. If this is a problem either make the heat sink floating or use an insulating sheet.

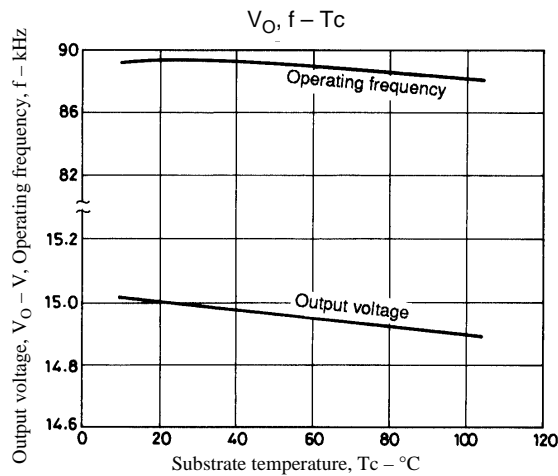
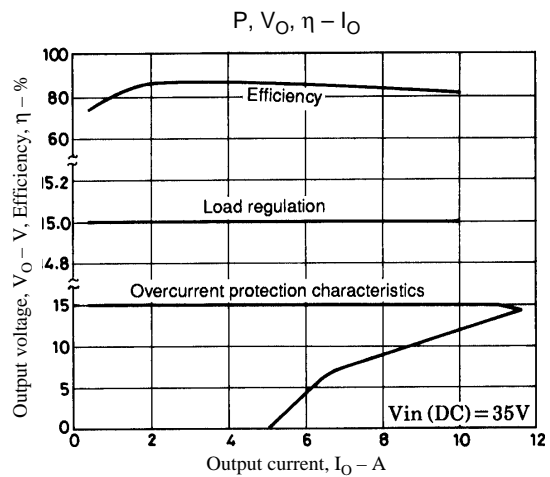
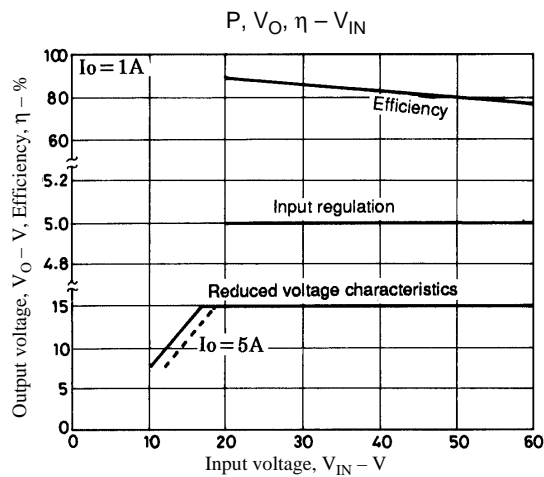

Thermal Design

The power dissipating sections of a power supply block consist of the power transistor (PTR), the flywheel diode (FWD), the choke coil, and the current detection resistor. Of these, the components that are incorporated in the hybrid IC itself are the PTR and the FWD.

Taking PT to be the power dissipated in the PTR and PF to be the power dissipated in the FWD, the power dissipation Pd for the whole hybrid IC and the heat sink thermal resistance θ_{c-a} can be expressed as follows.

$$P_d = (P_T + P_F) \quad [W]$$

$$\theta_{c-a} = \frac{T_c - T_a}{P_d} \quad [^{\circ}C/W]$$

Tc: Substrate temperature (105°C, maximum)

Ta: IC ambient temperature

The junction temperature, Tj, of each element can be expressed as follows.

$$T_j = P_D \times \theta_{j-c} + T_c \quad [^{\circ}C]$$

PD: Power loss for each element (PT, PF)

θ_{j-c} : The junction/case thermal resistance of each element

Thermal design consists of deriving the heat sink thermal resistance θ_{c-a} that satisfies the two thermal conditions, i.e., the maximum IC substrate temperature Tc max (105°C) and the maximum junction temperature Tj max for each semiconductor device, and then implementing that thermal resistance. Since thermal dissipation is greatly influenced by the ambient temperature, the structure of the equipment itself, and other factors, ample margins must be included in the thermal design to take them into account.

The figure below left shows the relationship between area and thermal resistance when an aluminum plate is used in the thermal design. The radiation characteristics of an aluminum plate can be improved by painting the surface in black. This can reduce the thermal resistance by 20% for a given surface area.

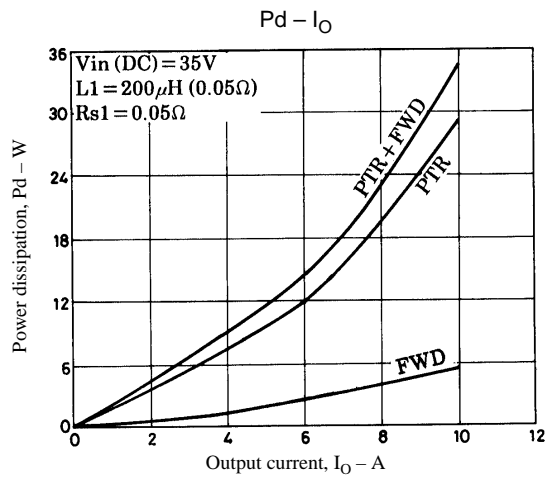
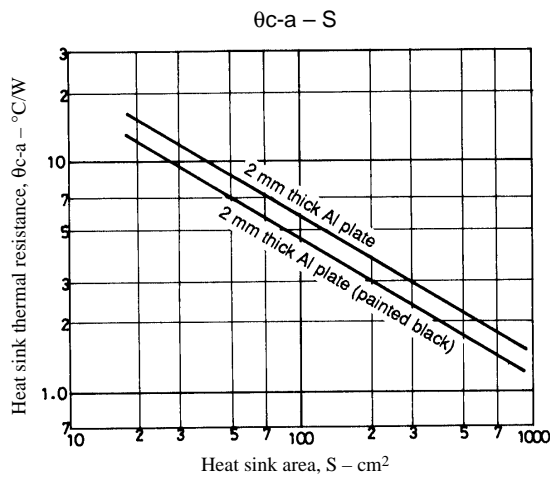

θ_{j-c} and Tj max for the STK732C

Parameter	θ_{j-c}	Tj max
PTR (FET)	3.5°C/W	150°C
FWD (FRD)	6.9°C/W	150°C

Notes on PC Board Production

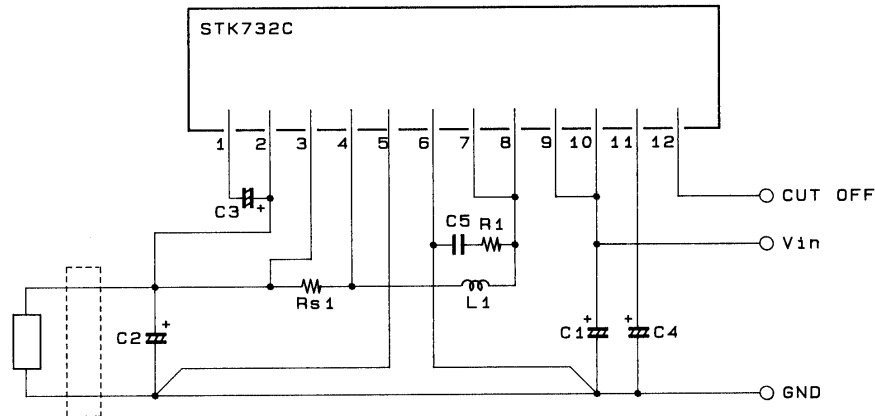

A01477

- Capacitor C1 should be placed as close as possible to the pin 10 input in the layout. (This is to prevent voltage drops in the input lines and pattern. Also, a separate smoothing capacitor is required if the input is a direct current input using rectified and smoothed AC.)
- Capacitor C2 should be placed as close as possible to the load in the layout. (This is to compensate for voltage drops due to load fluctuations.)
- Pins 2 and 5 are voltage sensing lines, and should be connected close to the load, i.e., close to C2. (This is to compensate for voltage drops in the pattern.)
- Pins 3 and 4 should be directly connected to the two terminals of the current detection resistor Rs1. (This is to prevent detection based on pattern resistances.)
- Pin 6 should be connected to the capacitor C1 ground using a thick, short line to reduce the related loop area. (This is to reduce switching spikes.)
- Power lines, i.e., lines that carry current, should be made as wide as possible in the pattern.
- When a ripple suppression LC filter is added, connect it at the location indicated by dotted lines in the figure. The sensing line from pin 2 should be connected to the same position (the C2 location) as it is when no filter is used.
- C5 and R1, which are used to reduce switching spikes, should be connected as close as possible to the IC pins.
- Locations where multiple pins are used (pins 7 and 8, and pins 9 and 10) must be connected in the printed circuit pattern.

Output On/Off Control (cutoff)

The on/off control function uses pin 12. When pin 12 is at the low level, the output will be cut off.

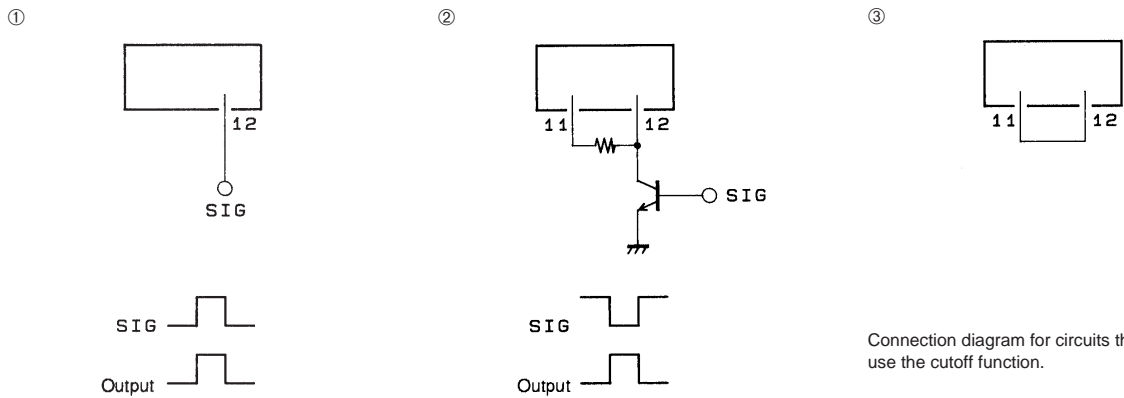

Connection diagram for circuits that do not use the cutoff function.

A01466

Choke Coil L1

1. The inductance value shown in the test circuit diagram is for times when the current is zero, and therefore is a reference value. Circuit operation should be checked in the actual mounted configuration of the final product.
2. The inductor L1 should be a product that can handle the high frequencies used in a switching power supply.
3. Be sure to use an inductor with appropriate rated current and magnetic saturation specifications.

Current Detection Resistor Rs1

1. Since this resistor carries large currents, its power dissipation must be taken into consideration.
2. Manufacturing variations in the resistor value can change the overcurrent protection circuit's operating point.

Two Output Power Supply Structural Example (connecting to an STK730)

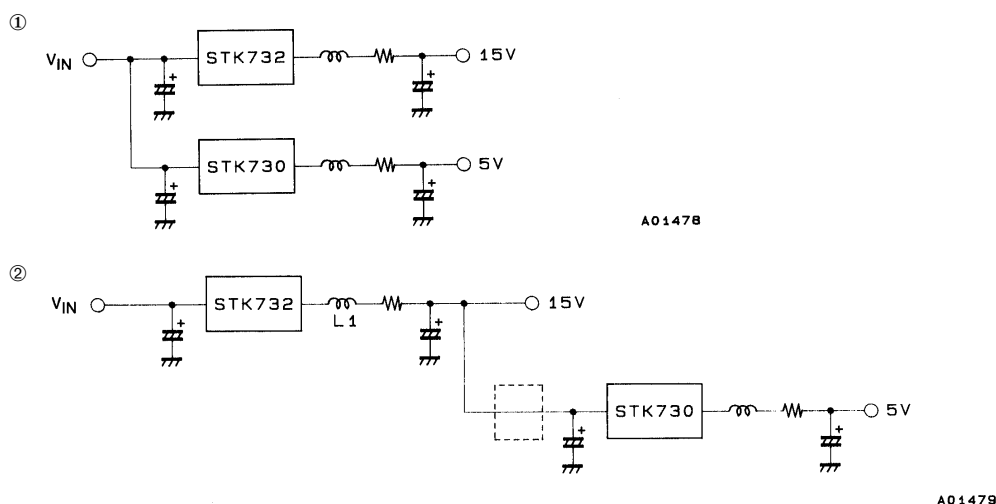

Note: It is possible for STK730 input ripple currents to cause L1 to vibrate audibly and adversely influence the 15 V system. If such problems occur, an inductor can be inserted at the point marked with dotted lines in the figure to form an LC filter.

Caution: Step down chopper power supplies can generate an overvoltage on the output side equivalent to the input voltage if there is an assembly error on the PC board or if the IC fails. Therefore we strongly recommend the use of a crowbar or other overvoltage protection circuit in power supply designs.

■ No products described or contained herein are intended for use in surgical implants, life-support systems, aerospace equipment, nuclear power control systems, vehicles, disaster/crime-prevention equipment and the like, the failure of which may directly or indirectly cause injury, death or property loss.

■ Anyone purchasing any products described or contained herein for an above-mentioned use shall:

- ① Accept full responsibility and indemnify and defend SANYO ELECTRIC CO., LTD., its affiliates, subsidiaries and distributors and all their officers and employees, jointly and severally, against any and all claims and litigation and all damages, cost and expenses associated with such use:
- ② Not impose any responsibility for any fault or negligence which may be cited in any such claim or litigation on SANYO ELECTRIC CO., LTD., its affiliates, subsidiaries and distributors or any of their officers and employees jointly or severally.

■ Information (including circuit diagrams and circuit parameters) herein is for example only; it is not guaranteed for volume production. SANYO believes information herein is accurate and reliable, but no guarantees are made or implied regarding its use or any infringements of intellectual property rights or other rights of third parties.

This catalog provides information as of November, 1997. Specifications and information herein are subject to change without notice.