

### Voltage-Mode PWM Controller IC

The KIA494AP/AF incorporates on a single monolithic chip all the functions required in the construction of a pulse-width-modulation control circuit. Designed primarily for power supply control, this device offers the systems engineer the flexibility to tailor the power supply control circuitry to a specific application.

The KIA494AP/AF contains two error amplifiers, an on-chip adjustable oscillator, a dead-time control(DTC) comparator, a pulse-steering control flip-flop, a 5-V, 5%-precision regulator, and output-control circuits.

The error amplifiers exhibit a common-mode voltage range from  $-0.3V$  to  $V_{CC} - 2V$ . The dead-time control comparator has a fixed offset that provides approximately 5% dead time.

The on-chip oscillator may be bypassed by terminating RT to the reference output and providing a sawtooth input to CT, or it may drive the common circuits in synchronous multiple-rail power supplies.

The uncommitted output transistors provide either common-emitter or emitter-follower output capability. The KIA494AP/AF provides for push-pull or single-ended output operation, which may be selected through the output-control function.

The architecture of this device prohibits the possibility of either output being pulsed twice during push-pull operation.

### FEATURES

- Completed PWM Power Control Circuitry.
- Uncommitted Outputs for 200mA Sink or Source Current.
- Output Control Selects Single-Ended or Push-Pull Operation.
- Internal Circuitry Prohibits Double Pulse at Either Output.
- Variable Dead Time Provides Control Over Total Range.
- Internal Regulator Provides a Stable 5V Reference Supply With 5% Tolerance.
- Circuit Architecture Allows Easy Synchronization.

### MAXIMUM RATINGS (Ta=25 °C)

ITEM	SYMBOL	RATING	UNIT
Supply Voltage	$V_{CC}$	41	V
Error Amplifier Input Voltage	$V_{IN}$	$V_{CC}+0.3$	V
Collector Output Voltage	$V_O$	41	V
Collector Output Current	$I_O$	250	mA
Power Consumption	KIA494AP	750	mW
	KIA494AF	400	
Operating Temperature	$T_{opr}$	-40 ~ 85	°C
Storage Temperature	$T_{stg}$	-65 ~ 150	°C

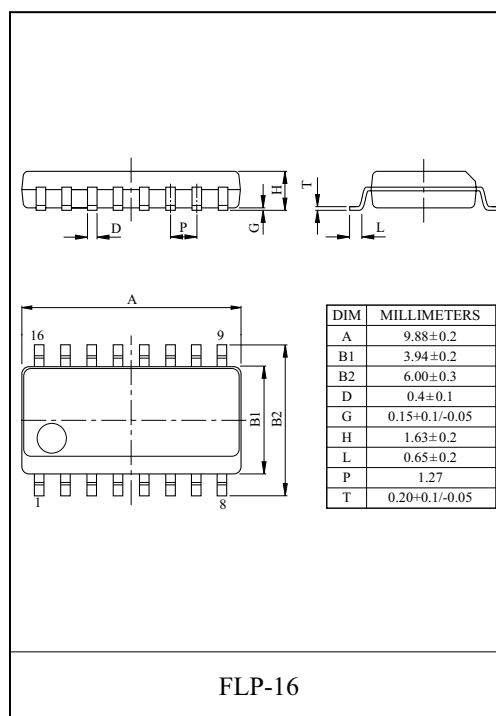
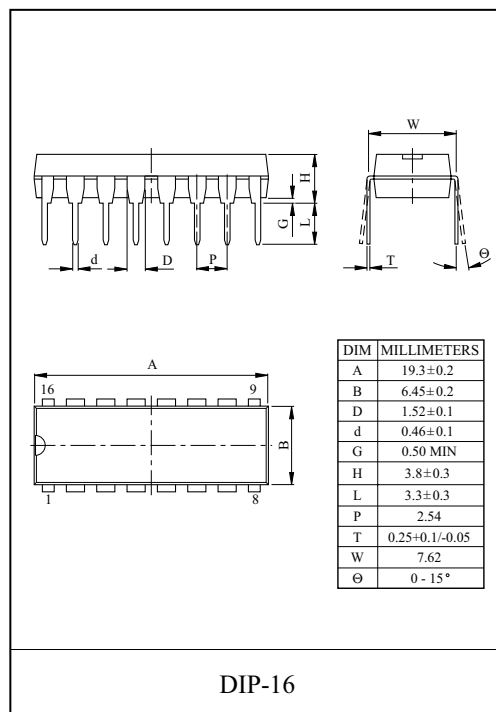

### FUNCTION TABLE

INPUT TO OUTPUT CTRL	OUTPUT FUNCTION
$V_I = GND$	Single-ended or paralled output
$V_I = V_{ref}$	Normal push-pull operation

# KIA494AP/AF

## RECOMMENDED OPERATING CONDITIONS

ITEM	SYMBOL	MIN.	TYP.	MAX.	UNIT
Supply Voltage	$V_{CC}$	7	-	40	V
Ampified Input Voltage	$V_{IN}$	-0.3	-	$V_{CC}-2.0$	V
Collector Output Voltage	$V_O$	-	-	40	V
Output Current (per one stage of output unit)	$I_O$	-	-	200	mA
Current Into Feedback Terminal	$I_{fb}$	-	-	0.3	mA
Timing Capacitor	$C_T$	0.47	-	10,000	nF
Timing Resister	$R_T$	1.8	-	500	k $\Omega$
Oscillation Frequency	$f_{osc}$	1	-	300	kHz
Operating Temperature	$T_{opr}$	-40	-	85	$^{\circ}C$

## ELECTRICAL CHARACTERISTICS

### REFERENCE VOLTAGE UNIT

CHARACTERISTIC	SYMBOL	TEST CONDITION	MIN.	TYP.	MAX.	UNIT
Output Voltage	$V_{ref}$	$I_{ref}=1mA, T_a=25^{\circ}C$	4.75	5.00	5.25	V
Input Stability	$R_{eg IN}$	$7V \leq V_{CC} \leq 40V, I_{ref}=1mA, T_a=25^{\circ}C$	-	2	25	mV
Load Stability	$R_{eg L}$	$1mA \leq I_{ref} \leq 10mA, T_a=25^{\circ}C$	-	1	15	
Output Voltage Temp. Change	$T_C V_{ref}$	$-40^{\circ}C \leq T_a \leq 85^{\circ}C, I_{ref}=1mA$	-	0.01	0.03	%/ $^{\circ}C$
Output Short-Circuit Current	$I_S$	$V_{ref}=0$	-	35	-	mA

### OSCILLATION UNIT

CHARACTERISTIC	SYMBOL	TEST CONDITION	MIN.	TYP.	MAX.	UNIT
Oscillation Frequency Set Value	$f_{OSC}$	$C_T=0.001 \mu F, R_T=30k \Omega$	-	40	-	kHz
Oscillation Frequency Setting Accuracy	$f_{DIV}$	$C_T=0.001 \mu F, R_T=30k \Omega$	-	3.0	-	%
Frequency Input Stability	$f_{VIN}$	$7V \leq V_{CC} \leq 40V, T_a=25^{\circ}C$	-	0.1	-	
Frequency Temp. Change	$f_{Ta}$	$-45^{\circ}C \leq T_a \leq 85^{\circ}C$	-	1	2	

### PAUSE PERIOD ADJUSTING UNIT

CHARACTERISTIC	SYMBOL	TEST CONDITION	MIN.	TYP.	MAX.	UNIT
Input Bias Current	$I_{IND}$	$0 \leq V_{IN} \leq 5.25V$ PIN 4	-	-2	-10	$\mu A$
Max. Duty (Each Output Stage)	Dy MAX.	$V_{IN}=0, C_T=0.1 \mu F, R_T=12k \Omega$	45	-	-	%
Input Threshold Voltage 1	$V_{TH-1}$	Output pulse 0% duty	-	2.8	3.3	V
Input Threshold Voltage 2	$V_{TH-2}$	Output pulse max. duty	0	-	-	

# KIA494AP/AF

## ERROR AMPLIFIER I II

CHARACTERISTIC	SYMBOL	TEST CONDITION	MIN.	TYP.	MAX.	UNIT
Input Offset Voltage	$V_{IO}$	$V_O$ PIN 3=2.5V	-	2	10	mV
Input Offset Current	$I_{IO}$	$V_O$ PIN 3=2.5V	-	5.0	250	nA
Input Bias Current	$I_{IB}$	$V_O$ PIN 3=2.5V	-	0.1	1	$\mu$ A
In-phase Input Voltage Range	$CMR_{IN}$	$7V \leq V_{CC} \leq 40V$	0.3	-	$V_{CC}-2$	V
Open Load Gain	$G_V$	$V_O$ PIN 3=0.5 ~ 3.5V, $R_L=2k \Omega$	70	95	-	dB
Unity Gain Frequency	$f_O$	$V_O$ PIN 3=0.5 ~ 3.5V, $R_L=2k \Omega$	-	350	-	kHz
Common-mode rejection Ratio	$CMRR$	$V_{CC}=40V$	65	90	-	dB
Output Sink Current (Feedback)	$I_{O+}$	$V_O$ PIN 3=0.7V	0.3	0.7	-	mA
Output Source Current (Feedback)	$I_{O+}$	$V_O$ PIN 3=3.5V	-2	-10	-	

## PWM COMPARATOR

CHARACTERISTIC	SYMBOL	TEST CONDITION	MIN.	TYP.	MAX.	UNIT
Input Threshold Voltage (Feedback)	$V_{TH}$	Zero duty cycle	-	4	4.5	V
Input Sink Current (Feedback)	$I_I$	$V_O$ PIN 3=0.7V	0.3	0.7	-	mA

## OUTPUT UNIT

CHARACTERISTIC	SYMBOL	TEST CONDITION	MIN.	TYP.	MAX.	UNIT	
Collector off-state Current	$I_{C(OFF)}$	$V_{CE}=40V$ , $V_{CC}=40V$ , Emitter grounded	-	-	100	$\mu$ A	
Emitter off-state Current	$I_{E(OFF)}$	$V_{CC}=V_C=40V$ , $V_E=0V$ Emitter follower	-	-	-100		
Emitter Saturation Voltage (Emitter grounded)	$V_{SAT(C)}$	$I_C=200mA$ , $V_E=0V$	-	1.1	1.3	V	
Collector Saturation Voltage (Emitter follower)	$V_{SAT(E)}$	$I_E=-200mA$ , $V_C=15V$	-	1.5	2.5		
Output Voltage Rise Time (Emitter grounded)	$t_{r1}$		-	100	200	ns	
Output Voltage Fall Time (Emitter follower)	$t_{f1}$		-	25	100		
Output Voltage Rise Time (Emitter follower)	$t_{r2}$		-	100	200		
Output Voltage Fall Time (Emitter grounded)	$t_{f2}$		-	40	100		
Output Control Input Operating Current	"L" State	$I_{OCL}$	$V_{OC} \leq 0.4V$	-	10	-	$\mu$ A
	"H" State	$I_{OCH}$	$V_{OC}=V_{ref}$	-	0.2	3.5	mA

## CURRENT CONSUMPTION (TOTAL)

CHARACTERISTIC	SYMBOL	TEST CONDITION	MIN.	TYP.	MAX.	UNIT
Standby Current	$I_{CC(S-B)}$	$V_{CC}=15V$ , Other terminal opened	-	6	10	mA
Average Supply Current	$I_{CC \text{ total}}$	$V_{(PIN4)}=2V$ , $C_T=0.01 \mu F$ $R_T=12k \Omega$ , $V_{CC}=15V$	-	7.5	-	

# KIA494AP/AF

## BLOCK DIAGRAM

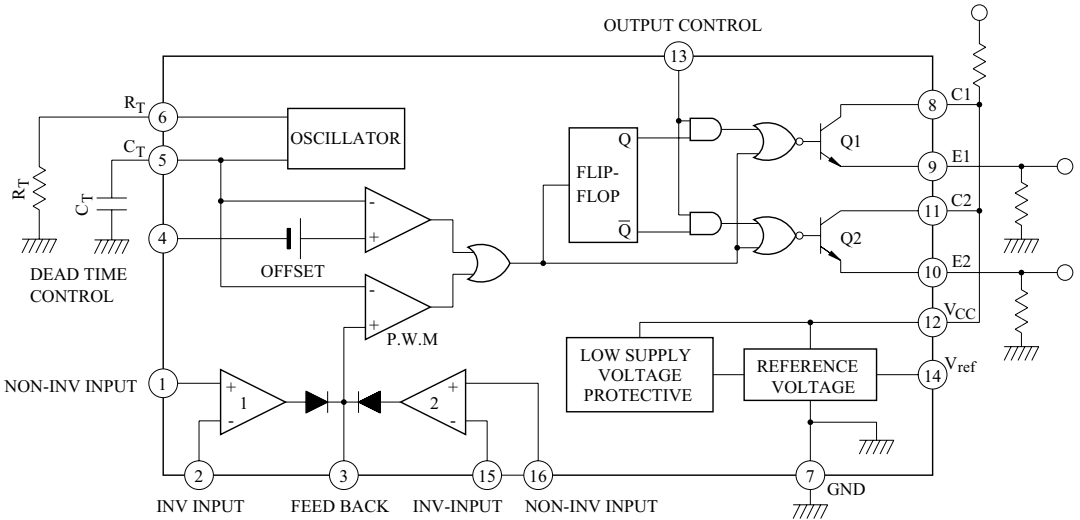

(Note) PIN 13 BECOMES SINGLE MODE AT "L" AND PUSH-PULL MODE AT "H"

## OPERATING WAVEFORM

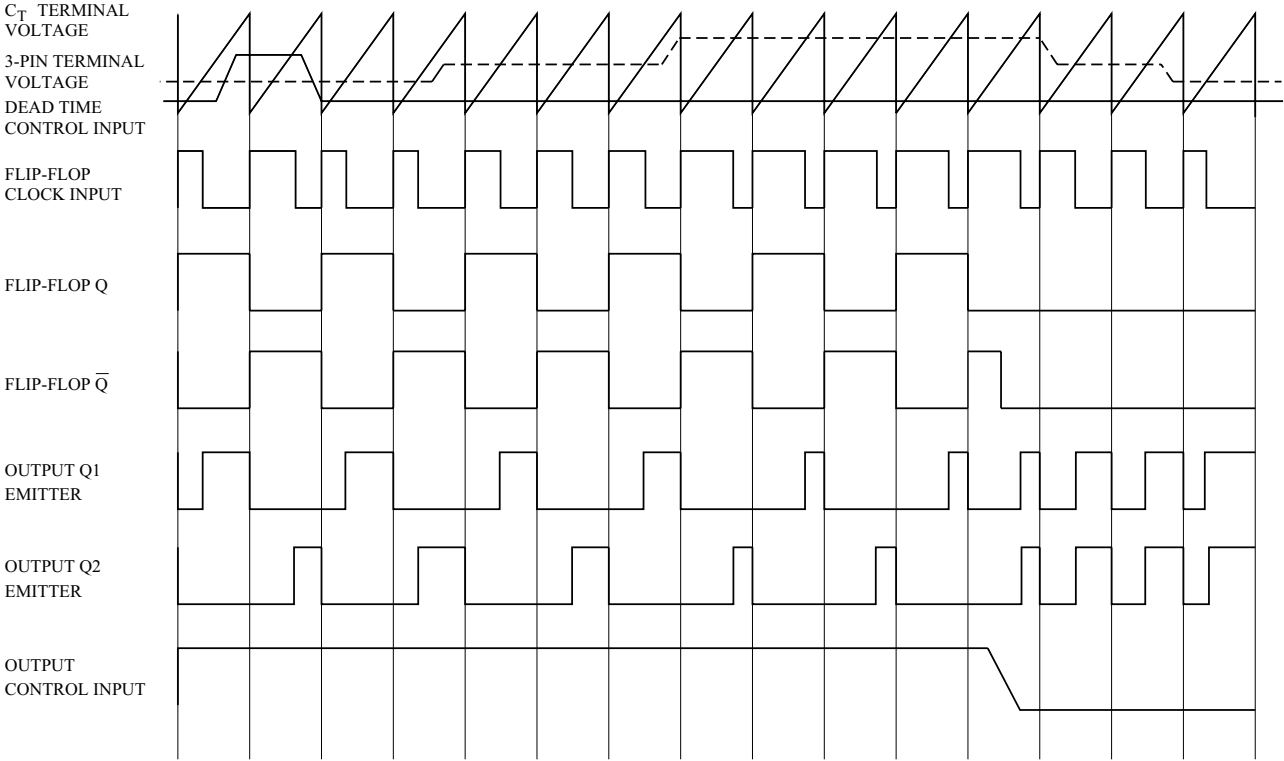

# KIA494AP/AF

## TEST CIRCUIT

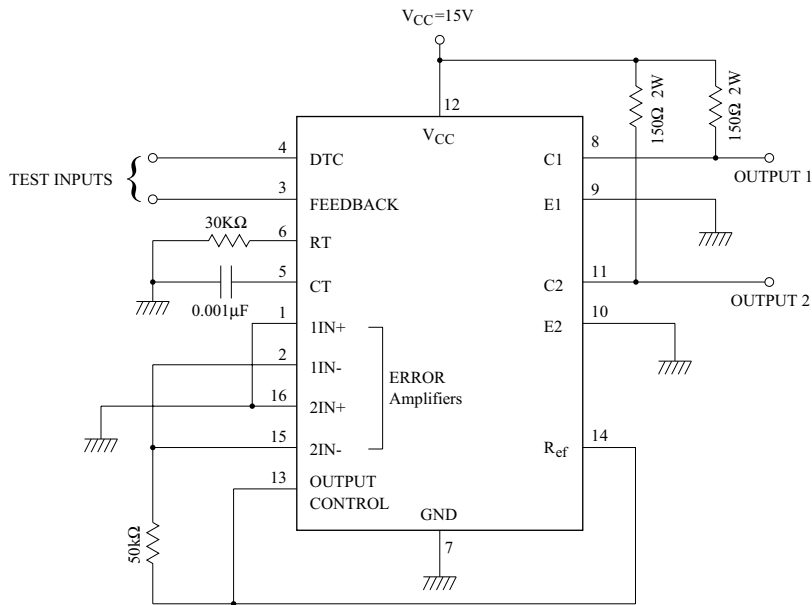

## Error Amplifier Characteristics

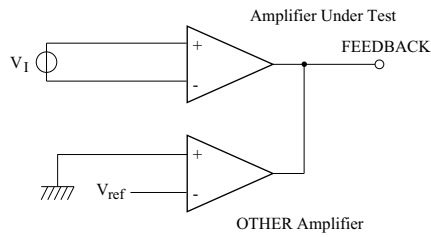

## Common-Emitter Configuration Test Circuit and Waveform

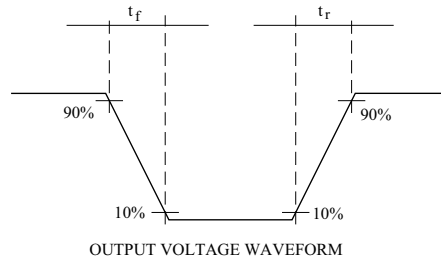
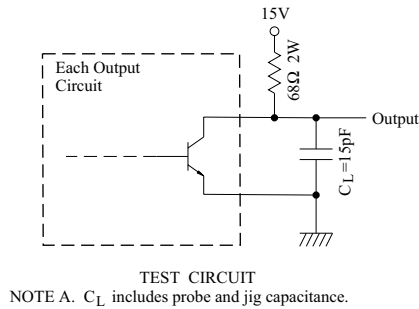

## Emitter-Follower Configuration Test Circuit and Waveform

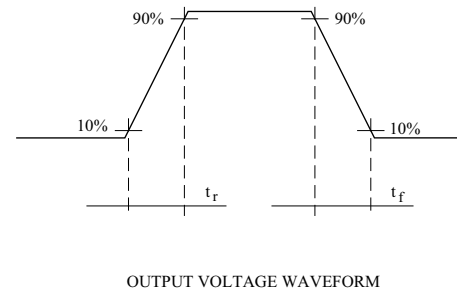
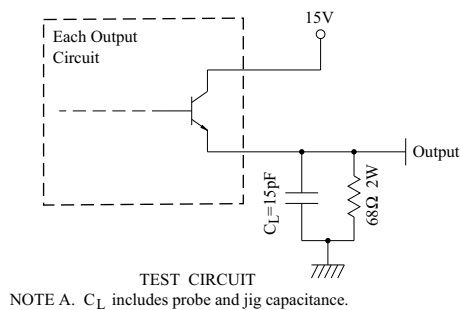

# KIA494AP/AF

