



## SOT-23 Plastic-Encapsulate Transistors

### SS8050LT1 TRANSISTOR ( NPN )

#### FEATURES

Power dissipation

$$P_{CM} : 0.3 \text{ W ( } T_{amb}=25 \text{ )}$$

Collector current

$$I_{CM} : 1.5 \text{ A}$$

Collector-base voltage

$$V_{(BR)CBO} : 40 \text{ V}$$

Operating and storage junction temperature range

$$T_J, T_{stg} : -55 \text{ to } +150$$

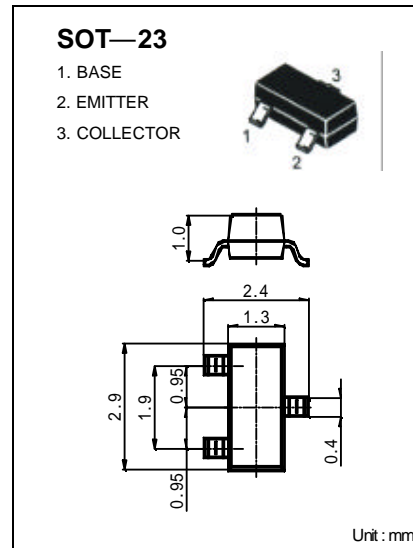

#### ELECTRICAL CHARACTERISTICS ( $T_{amb}=25$ unless otherwise specified )

Parameter	Symbol	Test conditions	MIN	TYP	MAX	UNIT
Collector-base breakdown voltage	$V_{(BR)CBO}$	$I_C=100 \mu A, I_E=0$	40			V
Collector-emitter breakdown voltage	$V_{(BR)CEO}$	$I_C=0.1mA, I_B=0$	25			V
Emitter-base breakdown voltage	$V_{(BR)EBO}$	$I_E=100 \mu A, I_C=0$	5			V
Collector cut-off current	$I_{CBO}$	$V_{CB}=40V, I_E=0$			0.1	$\mu A$
Collector cut-off current	$I_{CEO}$	$V_{CB}=20V, I_E=0$			0.1	$\mu A$
Emitter cut-off current	$I_{EBO}$	$V_{EB}=5V, I_C=0$			0.1	$\mu A$
DC current gain	$h_{FE(1)}$	$V_{CE}=1V, I_C=100mA$	120		350	
	$h_{FE(2)}$	$V_{CE}=1V, I_C=800mA$	40			
Collector-emitter saturation voltage	$V_{CE(sat)}$	$I_C=800mA, I_B=80mA$			0.5	V
Base-emitter saturation voltage	$V_{BE(sat)}$	$I_C=800mA, I_B=80mA$			1.2	V
Transition frequency	$f_T$	$V_{CE}=10V, I_C=50mA$ $f=30MHz$	100			MHz

#### CLASSIFICATION OF $h_{FE(1)}$

Rank	L	H
Range	120-200	200-350

#### DEVICE MARKING:

8050LT1=Y1

## SOT-23 PACKAGE OUTLINE DIMENSIONS

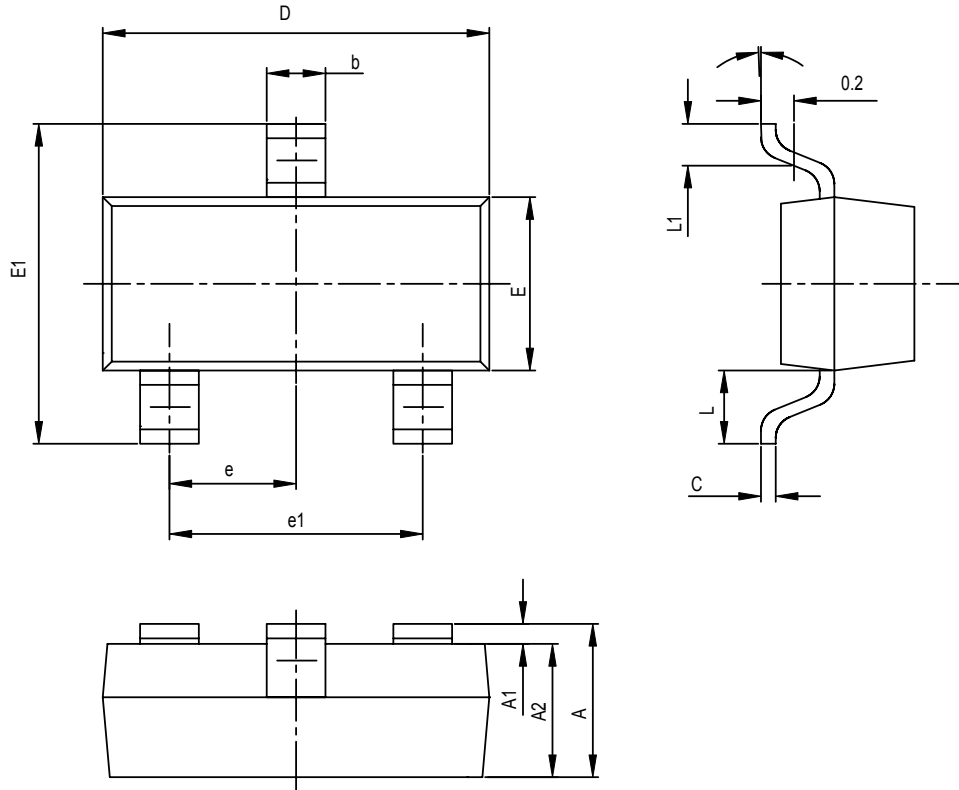

Symbol	Dimensions In Millimeters		Dimensions In Inches	
	Min	Max	Min	Max
A	0.900	1.100	0.035	0.043
A1	0.000	0.100	0.000	0.004
A2	0.900	1.000	0.035	0.039
b	0.300	0.500	0.012	0.020
c	0.080	0.150	0.003	0.006
D	2.800	3.000	0.110	0.118
E	1.200	1.400	0.047	0.055
E1	2.250	2.550	0.089	0.100
e	0.950TPY		0.037TPY	
e1	1.800	2.000	0.071	0.079
L	0.550REF		0.022REF	
L1	0.300	0.500	0.012	0.020
$\theta$	0°	8°	0°	8°