

Ø 5,118" x 2,539" Ø 130 x 64,5 mm

80CE

ETRI®

AC High Performance Fans

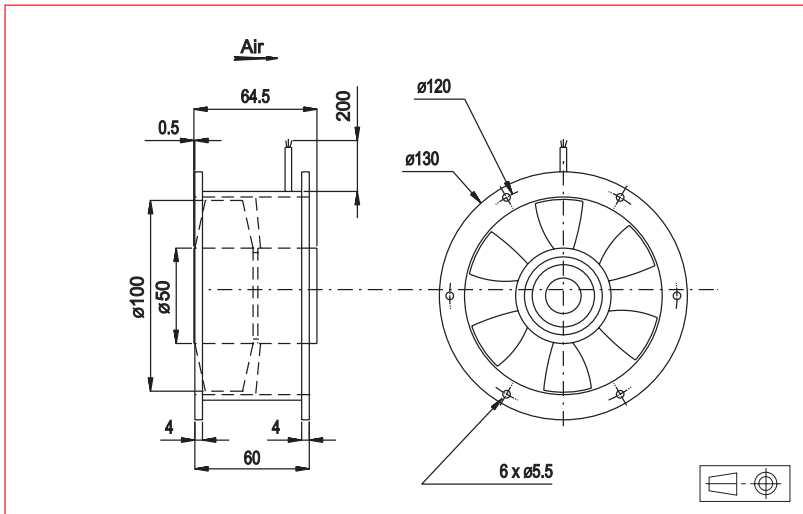

Approvals

CE, NATO codification

Life expectancy

L-10 LIFE AT 40°C:
25 000 hours

AC Motor

Housing material: aluminium
Impeller material: aluminium
Weight: 700 g
Bearing system: ball bearings

Available with:

- Square flanges (113x113 mm)

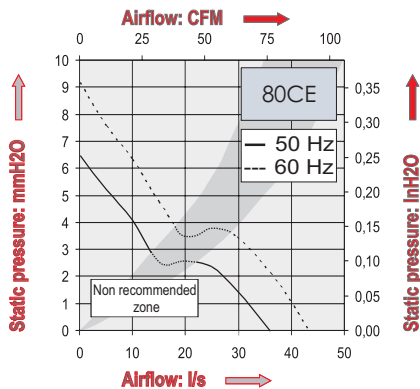

Part Number	Nominal voltage	Airflow	Noise level	Nominal speed	Frequency	Phases	Capacitor (not included)	Input power	Nominal Current	Starting Current	Connection type		Operating temperature	
	V	l/s	dB(A)	RPM	Hz		µF	W	mA	mA	Leads	Terminals	Min.°C	Max.°C
80CE0161C13	220	36	45	2900	50	3		23	80	110	X		-10	70
	220	44	49	3400	60	3		18	65	110	X		-10	70
	220	36	45	2900	50	1	1	17	80	105	X		-10	70
	220	44	49	3400	60	1	1	16	75	105	X		-10	70

Additional versions:

Salt spray protected - Shock and vibration protected - Marine specifications
Wide temperature range - Other voltages (consult factory)

Accessories:

Refer to Accessories leaflet

ETRI® • <http://www.etrinet.com> • e-mail: info@etrinet.com • ETRI is a trademark of ECOFIT



Non contractual document. Specifications are subject to change without prior notice. Pictures for information only. Edition 2008