

# SM 1500 Series

1500 WATTS PROGRAMMABLE DC SUPPLY

## Features

- Constant voltage and constant current operation
- Parallel operation master/slave
- EMC standard EN61204-3
- CE marked
- Optional ethernet, RS232, IEEE 488 programming
- Designed for long life at full power



## Specifications

### INPUT

Input voltage	90-265Vac
Frequency	48Hz–62Hz
Inrush current	27A @ 115Vac, 22A @ 230Vac.
Power factor	0.99
Isolation	I/P to O/P: 3.75kVrms (1min.), Creepage: 8mm I/P to Case: 2.5kVrms, O/P to Case: 600Vdc

### OUTPUT

Output voltage	See table.
Output voltage adjustment	0%–100%
Output current	See table.
Output current adjustment	0%–100%
Resolution	0.03% voltage and current control with 10 turn potentiometers.
Overload protection	Yes
Short circuit protection	Yes
Temperature coefficient	CV: $35 \times 10^{-6}$ per °C, CC: $60 \times 10^{-6}$ per °C
Load regulation	0%–100% load – see table
Line regulation	Line $\pm 10\%$ – see table
Ripple & Noise	See table
Stability	CV: $6 \times 10^{-5}$ , CC: $9 \times 10^{-5}$
Output impedance (0-1kHz; 1-100kHz)	SM15-100: < 1.3m $\Omega$ ; < 25m $\Omega$ SM35-45: < 1.7m $\Omega$ ; < 30m $\Omega$ SM52-30: < 3.5m $\Omega$ ; < 30m $\Omega$ SM52-AR-60: < 3.3m $\Omega$ ; < 40m $\Omega$ SM70-20: < 7.5m $\Omega$ ; < 30m $\Omega$ SM120-13: < 63m $\Omega$ ; < 0.6 $\Omega$ SM300-5: < 125m $\Omega$ ; < 1 $\Omega$ SM400-AR-8: < 83m $\Omega$ ; < 1.3 $\Omega$
Recovery time	(50%–100% load step): 100 $\mu$ S.
Remote sense	2V max. per lead compensation.

### OPERATING

Efficiency	87%–91%.
Switching frequency	100kHz.
Thermal protection	Yes.
Programming	Analogue Programming of voltage and current by 0-5V.
Programming speed	See table.
Master/Slave operation	Parallel and series operation with equal current and voltage sharing. In this way two or more SM-units can together be used as one high power unit. Voltage and current of the units is controlled by the master (by potentiometers or by programming). Series operation up to 600V.
Metering	Digital meters standard.
Indicators	CV/CC mode, OVP triggered LEDs.

### BATTERY CHARGING

The CV/CC regulated power supplies are very suitable for battery charging. Ask for the special datasheet "BATTERY CHARGING WITH SM-series POWER SUPPLIES". This datasheet contains information about protective measures against accidental battery reversing.

### ENVIRONMENTAL

Operating temperature	-20°C to 50°C.
Cooling	Low noise blower, fan speed adapts to temperature of internal heatsink. (from left to right).

### STANDARDS AND APPROVALS

Safety standards	EN60950 / EN61010
EMC standards	EN61204-3, EN61000-6-2
EMI standards	EN61000-6-3 (EN55022B)

### MECHANICAL

Mounting	Bench or 19" rack mounting
----------	----------------------------

# SM 1500 Series

1500 WATTS PROGRAMMABLE DC SUPPLY

## Selection Table

MODEL NUMBER	OUTPUT VOLTAGE (0V TO)	OUTPUT CURRENT (0A TO)	RIPPLE & NOISE		PROGRAMMING SPEED (0V TO V MAX.)	LOAD REG. 0%-100%		LINE REG. 200-264VAC	
			CV	CC		CV	CC	CV	CC
SM15-100	15V	100A	8mVp-p	80mA	0.20ms (100% load)	0.5mV	5mA	0.2mV	1mA
SM35-45	35V	45A	8mVp-p	15mA	0.27ms (100% load)	1mV	3mA	0.5mV	0.5mA
SM52-30	52V	30A	15mVp-p	10mA	0.31ms (100% load)	2mV	1.5mA	0.7mV	0.5mA
SM70-22	70V	22A	15mVp-p	10mA	0.47ms (100% load)	2.5mV	1mA	1mV	0.25mA
SM120-13	120V	13A	30mVp-p	6mA	0.46ms (100% load)	4mV	0.6mA	2mV	0.2mA
SM300-5	300V	5A	50mVp-p	4mA	1.0ms (100% load)	10mV	0.5mA	3mV	0.1mA
SM52-AR-60	0-26V	60A	15mVp-p	30/10mA	0.44ms (100% load)	2mV	2mA	0.7mV	1mA
	26-52V	30A			0.53ms (100% load)				
SM400-AR-8	0-200V	8A	80mVp-p	6/3mA	0.35ms (100% load)	12mV	0.5mA	4mV	0.2mA
	200-400V	4A			0.98ms (100% load)				

## OPTIONS

Screwdriver adjustment - option P001

Master / slave operation

Battery charging - SM52-30: P197, SM52-AR-60: P198, SM120-13: P199, SM300-5: P200, SM400-AR-8: P201.

Increased max. output voltage / current - option P069

Enforced secondary isolation 1000V - option P089

High speed programming - SM15-100: P210, SM35-45: P211, SM52-30: P212, SM52-AR-60: P213, SM70-22: P214, SM120-13: P215, SM300-5: P216, SM400-AR-8: P217.

Power sink for 2 quadrant operation - SM15-100: P202, SM35-45: P203, SM52-30: P204, SM52-AR-60: P205, SM70-22: P206.

Built-in ISO AMP CARD for isolated analog programming - option P218

Built-in ethernet power supply controller - option P177

Built-in RS232 power supply controller - option P183

Built-in IEEE488 power supply controller - option P184

## Technical Illustrations

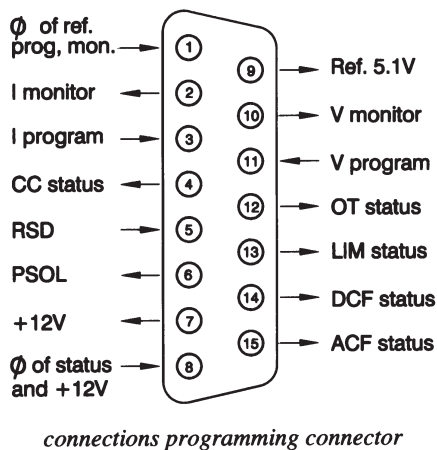

CV = Constant Voltage  
CC = Constant Current

Specifications measured at  $t_{amb} = 25 \pm 5^\circ C$  and  $V_{in} = 230V AC$ , 50 Hz, unless otherwise noted.

The information in this document is subject to change without notice

