

OVERVIEW

The SM5304AV is a 75Ω terminating resistance drive video buffer with built-in analog filter. The filter cutoff frequency, controlled by the resistance connected to RFC pin, can be set to match any system resolution. The output buffer can be selected 0dB, 6dB, and 12dB. The feedback point occurs after the external coupling capacitors, and the coupling capacitances can be reduced.

FEATURES

- 5V ± 10% supply voltage
- Adjustable cutoff frequency using external resistor
- 0dB, 6dB, 12dB selectable gain using logic signal
- ± 0.5dB output gain error
- Two systems (two load resistances) can be driven
- 0.7% output signal harmonic distortion
- Sag compensation circuit built-in
- Package: 8-pin VSOP (Pb free)

APPLICATIONS

- DVD
- Digital still camera
- Digital VHS

ORDERING INFORMATION

Device	Package
SM5304AV	8-pin VSOP

PINOUT

(Top view)

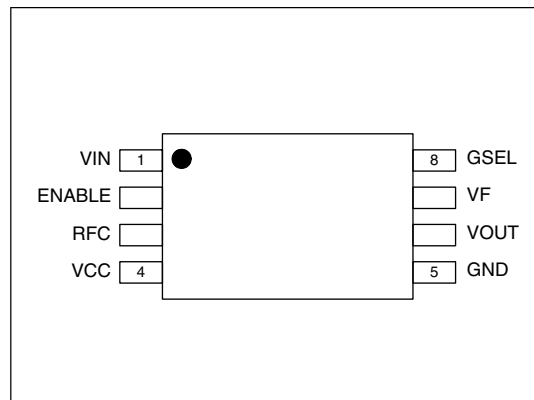

PACKAGE DIMENSIONS

(Unit: mm)

Weight: 0.04g

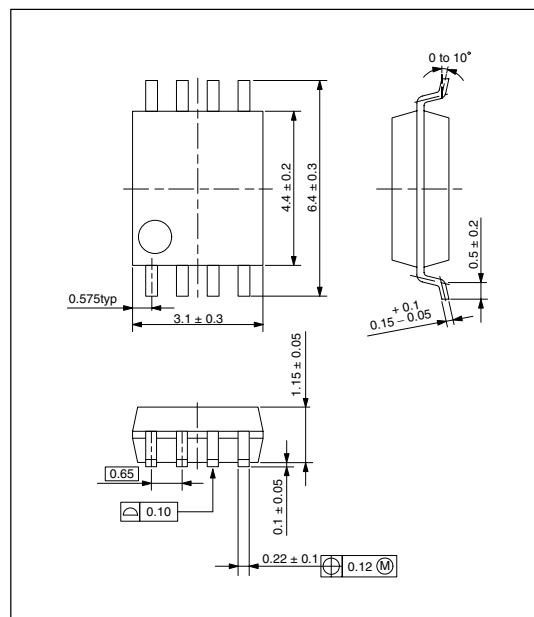

BLOCK DIAGRAM

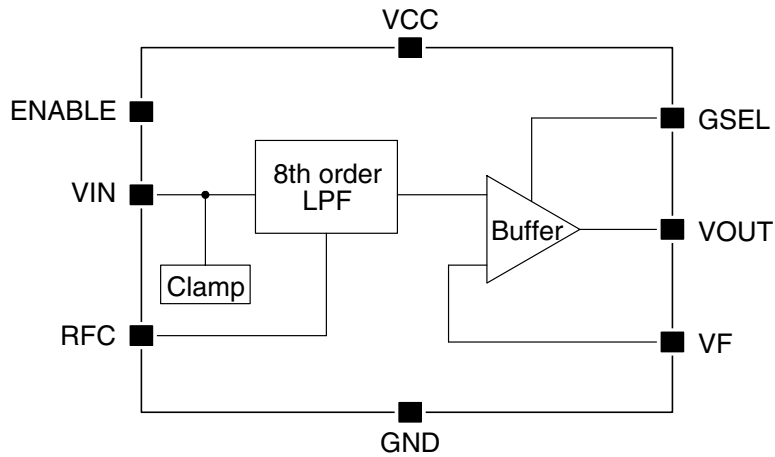

PIN DESCRIPTION

Number	Name	I/O ¹	A/D ²	Description
1	VIN	I	A	Input signal pin
2	ENABLE	I	D	Enable signal input pin (with pull-down resistor)
3	RFC	O	A	LPF cutoff frequency set pin
4	VCC	-	-	5V supply pin
5	GND	-	-	Ground pin
6	VOUT	O	A	Output signal pin
7	VF	I	A	Output signal feedback pin for sag compensation circuit
8	GSEL	I	D	Gain set signal input pin

1. I: input, O: output

2. A: analog, D: digital

SPECIFICATIONS

Absolute Maximum Ratings

Parameter	Symbol	Condition	Rating	Unit
Supply voltage range	V_{CC}		- 0.3 to 7	V
Storage temperature range	T_{STG}		- 55 to + 125	°C
Power dissipation	P_D	$\theta_{ja} = 214^{\circ}\text{C}/\text{W}$ (Note 1)	300	mW
Junction temperature	T_j		125	°C

(Note 1) T_j is calculated by $T_j = P_D \times \theta_{ja} + T_a$ (P_D : Power dissipation (= $V_{CC} \times I_{CC}$), θ_{ja} : Thermal resistance, T_a : Ambient temperature).
 θ_{ja} is measured value in the mounting condition which NPC specified. (glass epoxy board, board size: 40mm × 40mm, wiring density: 10%, still air)

Recommended Operating Conditions

Parameter	Symbol	Condition	Rating	Unit
Supply voltage range	V_{CC}		4.5 to 5.5	V
Operating temperature range	T_a		- 40 to 85	°C

Digital Characteristics

$V_{CC} = 5.0\text{V}$, $T_a = 25^{\circ}\text{C}$, unless otherwise noted.

Parameter	Symbol	Condition	Rating			Unit	Test level
			min	typ	max		
HIGH-level input voltage 1	V_{IH1}	ENABLE pin	2.4	-	-	V	I
LOW-level input voltage 1	V_{IL1}	ENABLE pin	-	-	0.8	V	I
HIGH-level input voltage 2	V_{IH2}	GSEL pin	$V_{CC} - 0.5$	-	-	V	I
LOW-level input voltage 2	V_{IL2}	GSEL pin	-	-	0.5	V	I
Open-circuit input voltage	V_{OPEN}	GSEL pin	$V_{CC}/2 - 0.5$	-	$V_{CC}/2 + 0.5$	V	I
HIGH-level input current 1	I_{IH1}	ENABLE pin, $V_{IN} = V_{CC}$	-	100	200	μA	I
Input leakage current 1	I_{LL1}	ENABLE pin, $V_{IN} = 0\text{V}$	-	-	1	μA	I
Input leakage current 2	I_{LL2}	GSEL pin, ENABLE = "LOW", $V_{IN} = 0\text{V}$	-	-	1	μA	I
HIGH-level input current 2	I_{IH2}	GSEL pin, ENABLE = "HIGH", $V_{IN} = V_{CC}$	-	250	400	μA	I
LOW-level input current 2	I_{IL2}	GSEL pin, ENABLE = "HIGH", $V_{IN} = 0\text{V}$	-	250	400	μA	I
Pull-down resistance 1	R_{PD1}	ENABLE pin	40	50	60	$\text{k}\Omega$	I
Pull-down resistance 2	R_{PD2}	GSEL pin when ENABLE = "LOW"	16	20	24	$\text{k}\Omega$	I

Electrical Characteristics

$V_{CC} = 5.0V$, $T_a = 25^\circ C$, unless otherwise noted, See Measurement circuit.

Parameter	Symbol	Condition	Rating			Unit	Test level
			min	typ	max		
Current consumption 1	I_{CC1}	$V_{CC} = 4.5$ to $5.5V$, $R_{FC} = 2.7k\Omega$, $T_a = -40$ to $85^\circ C$, ENABLE = "HIGH"	-	41	52	mA	II
Current consumption 2	I_{CC2}	$V_{CC} = 4.5$ to $5.5V$, $R_{FC} = 4.3k\Omega$, $T_a = -40$ to $85^\circ C$, ENABLE = "HIGH"	-	39	49	mA	II
Current consumption 3	I_{CC3}	ENABLE = "LOW", GSEL = "LOW"	-	-	10	μA	I
Signal gain 1	A_{V1}	GSEL = "LOW", $R_{FC} = 4.3k\Omega$, $f = 1MHz$	5.7	6.2	6.7	dB	I
Signal gain 2	A_{V2}	GSEL = "Open cct", $R_{FC} = 4.3k\Omega$, $f = 1MHz$	-0.3	0.2	0.7	dB	I
Signal gain 3	A_{V3}	GSEL = "HIGH", $R_{FC} = 4.3k\Omega$, $f = 1MHz$	11.5	12.0	12.5	dB	I
Input voltage range	V_{IN}	AC-coupled input, $f = 100kHz$	1.4	-	-	Vp-p	I
Maximum output voltage	V_{out}	Output conditions shown in Typical Connection	2.4	-	-	Vp-p	I
Clamp voltage	V_{CLMP}		0.9	1.2	1.45	V	I
Overshoot/ Undershoot ¹	V_{OS}		-	4.0	-	%	III
Output harmonic distortion	T_{HD}	$f = 1MHz$, $V_{out} = 2Vp-p$, $R_{FC} = 4.3k\Omega$	-	0.7	-	%	III
Cutoff frequency control range	f_C		2	-	10	MHz	I
Resistor (R_{FC}) value range ²	R_{FC}		2.7	-	18	$k\Omega$	I
Cutoff frequency error	ΔF_C		-	-	± 15	%	I
4fc attenuation	f_{SB}	$f \geq 4fc$	-	-70	-	dB	III
Group delay variation	ΔT_{PD}	$R_{FC} = 4.3k\Omega$, 100kHz and 5MHz group delay difference	-	12	-	ns	III

1. The percentage output pulse overshoot when $R_{FC} = 4.3k\Omega$, gain = 6dB, and input pulse = 1Vp-p (rise and fall times = 100ns).
2. Refer to "R_{FC} Frequency Control" for the Cutoff frequency vs. R_{FC} characteristics.

Test level

I : Valid for 100% product tests conducted at $T_a = 25^\circ C$

II : 100% valid for alternative tests conducted at $T_a = 25^\circ C$

III: Guaranteed based on design and characteristics evaluation

Measurement circuit

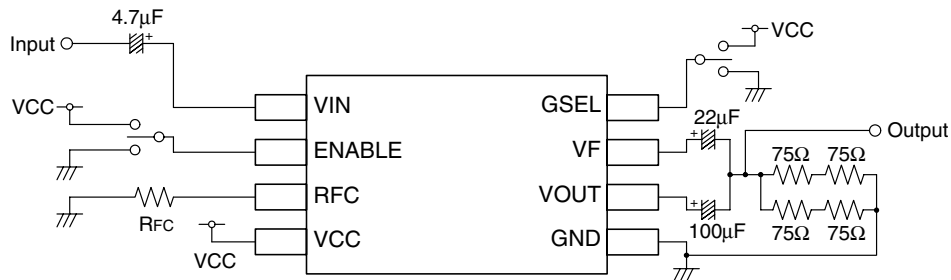

FUNCTIONAL DESCRIPTION

R_{FC} Frequency Control

Characteristics

The cutoff frequency (f_c) is controlled by the resistor connected to RFC pin (R_{FC}). The characteristics about f_c versus R_{FC} is shown in table 1.

Table 1. R_{FC} and frequency control range

R _{FC} [kΩ]	Cutoff frequency [MHz]
18	1.9
15	2.3
12	2.8
10	3.3
8.2	3.9
6.8	4.6
5.6	5.5
4.7	6.4
4.3	6.9
3.9	7.5
3.3	8.7
2.7	10.5

Adjustment methods

It can set up by the following methods. Since resistance affects cutoff frequency, please use a high precise thing.

■ Fixed resistor

The frequency can be adjusted using an external resistor connected to RFC.

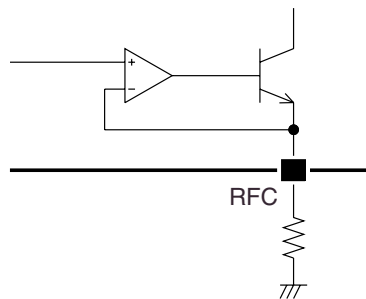

- Variable resistor

The frequency can be adjusted using a preset variable resistor VR connected to RFC.

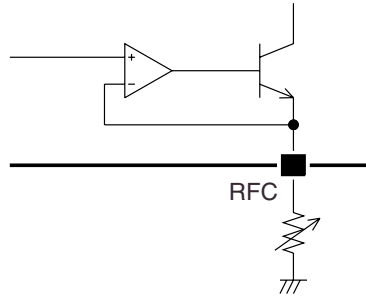

- Voltage control

The frequency can be adjusted by voltage control of the resistor connected to RFC using a DC voltage supply (for example, using a DAC). In this case, the adjusting voltage must be controlled such that it does not exceed the RFC pin voltage (1.5V typ).

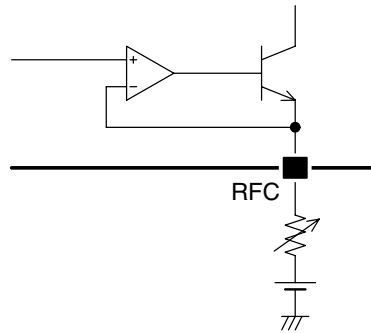

- Resistor switch control

The frequency can be adjusted by switching the resistance connected to RFC using logic voltage control.

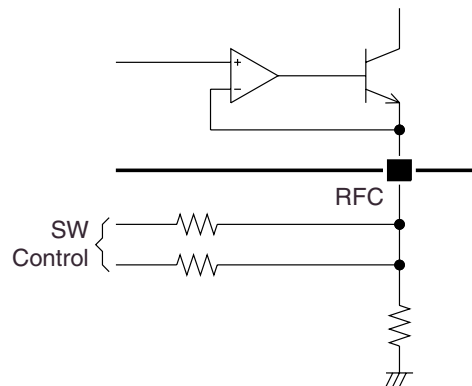

Gain Control Function and Enable Function

ENABLE pin	GSEL pin	Gain setting
HIGH (Enable)	LOW	6dB
	Open	0dB
	HIGH	12dB
LOW (Disable)	LOW	High impedance output
	Open	
	HIGH	

When setting GSEL pin to open, in order to prevent incorrect operation by the external noise, it recommends connecting a capacitor between GSEL pin and GND pin.

Equivalent circuit

The equivalent circuit of GSEL pin and ENABLE pin is shown in figure. GSEL pin is connected only to pull-down resistor in the state of disable.

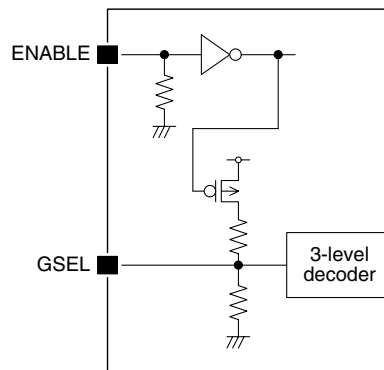

TYPICAL CHARACTERISTICS

$V_{CC} = 5.0V$, $R_{FC} = 4.3k\Omega$, $T_a = 25^\circ C$, unless otherwise noted.

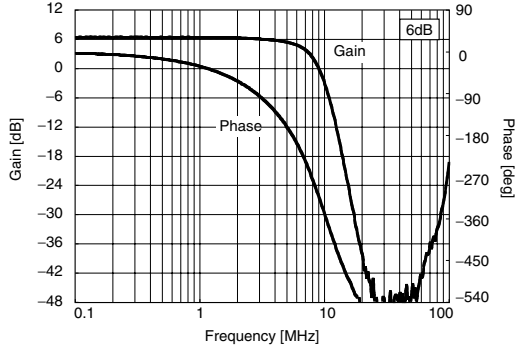

Figure 1. Phase vs Frequency

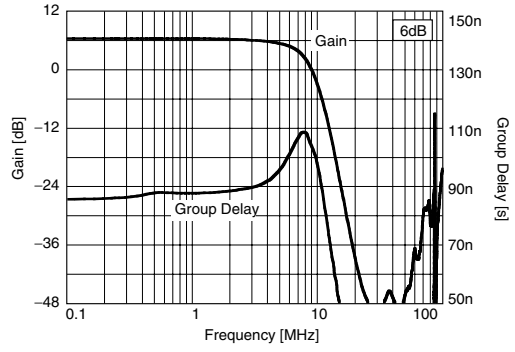

Figure 2. Group Delay vs Frequency

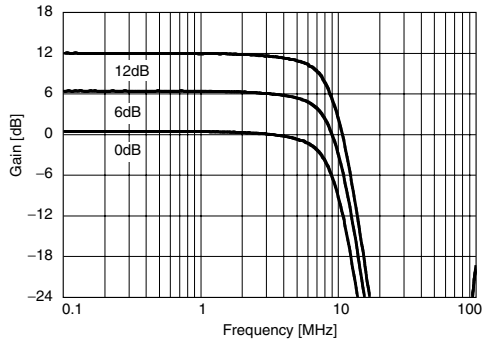

Figure 3. Gain vs Frequency ($R_{fc} = 4.3k\Omega$)

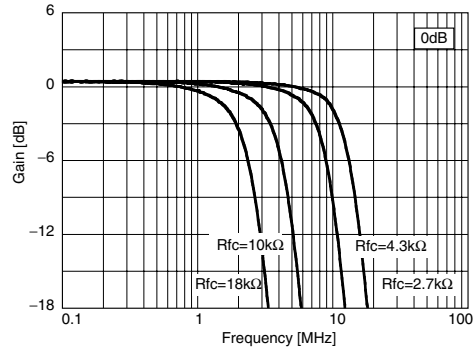

Figure 4. Gain vs Frequency (0dB)

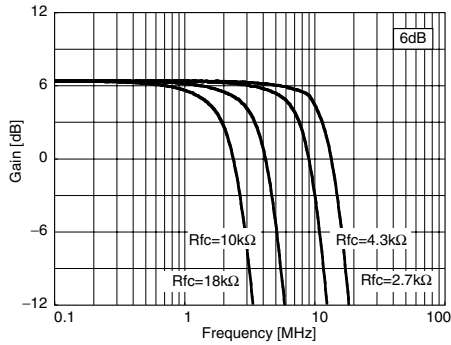

Figure 5. Gain vs Frequency (6dB)

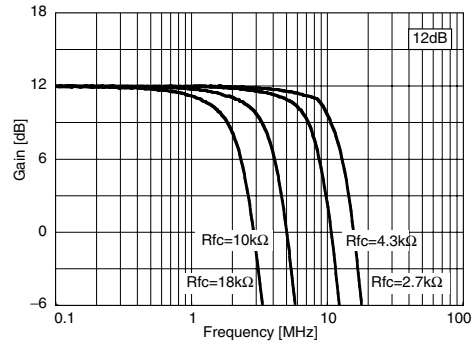

Figure 6. Gain vs Frequency (12dB)

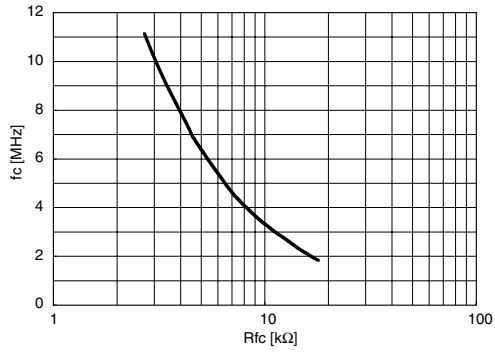

Figure 7. f_c vs R_{fc}

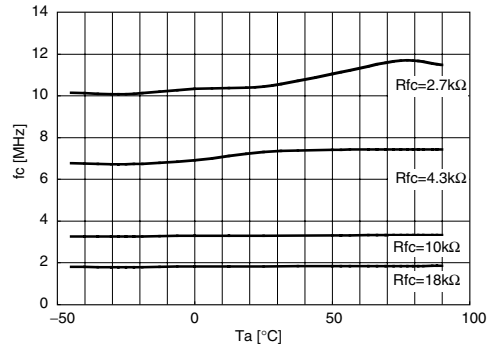

Figure 8. f_c vs T_a

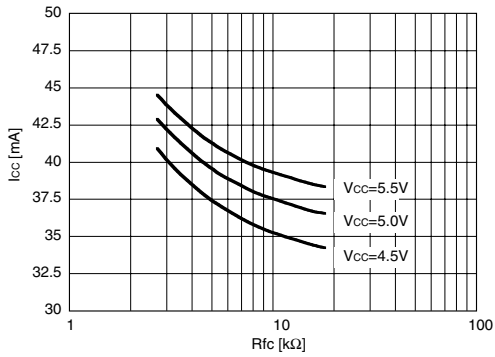

Figure 9. I_{CC} vs R_{fc}

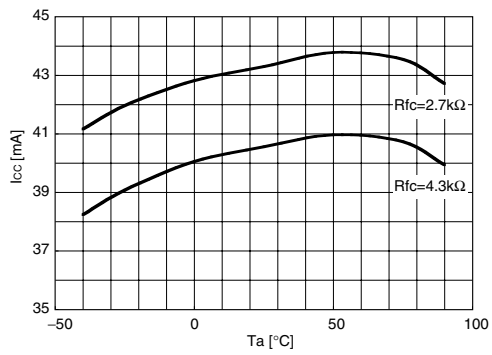

Figure 10. I_{CC} vs T_a

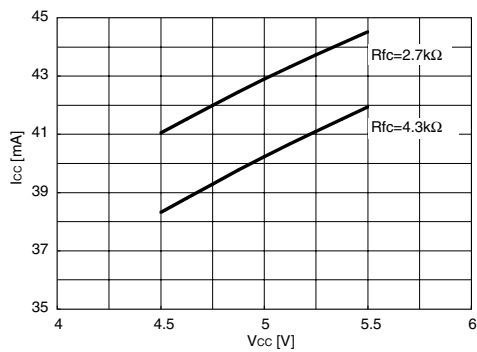

Figure 11. I_{CC} vs V_{CC}

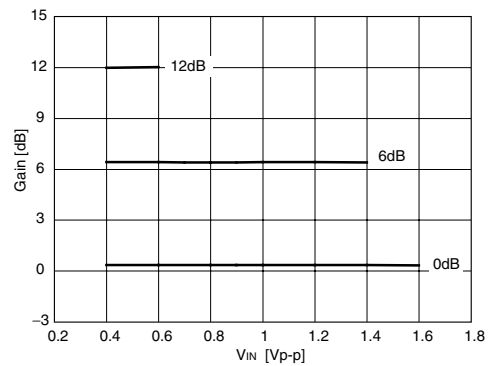

Figure 12. Gain vs V_{IN}

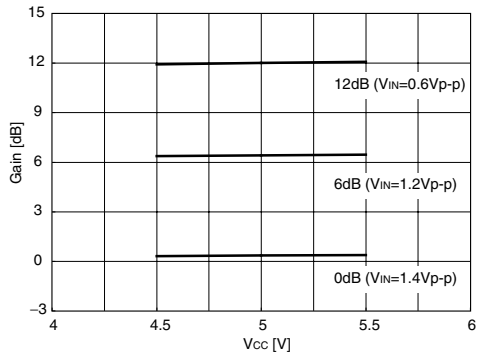

Figure 13. Gain vs V_{CC}

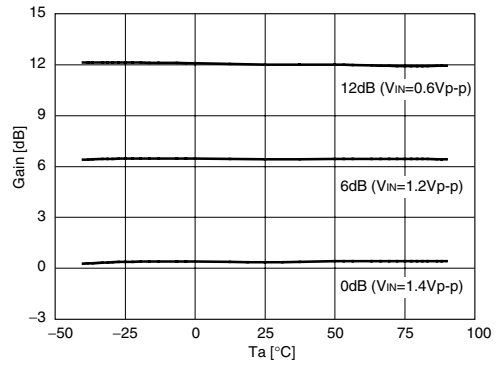

Figure 14. Gain vs Ta

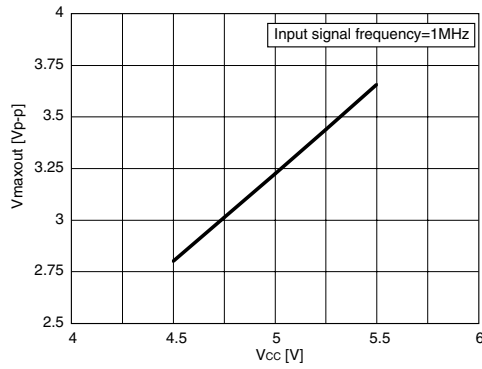
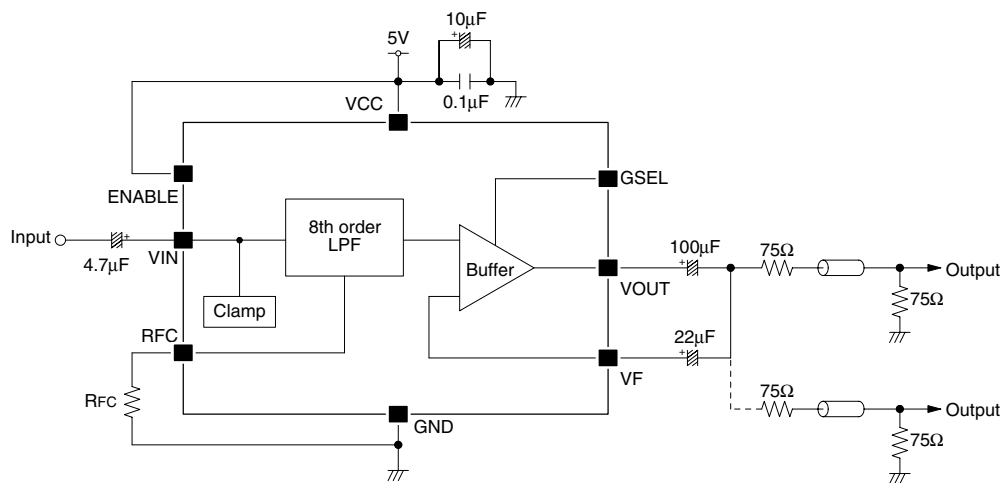

Figure 15. V_{maxout} vs V_{CC}

TYPICAL CONNECTION



NOTES ON USE

Capacitors Between Power Supply Pin

Please be sure to connect a capacitor between power supply pin (VCC, GND) for preventing the oscillation of an output and supplying a power supply stable. Electrolytic capacitor about $1\mu\text{F}$ to $10\mu\text{F}$ and ceramic capacitor about $0.01\mu\text{F}$ to $0.1\mu\text{F}$ are recommended. Please connect a ceramic capacitor to near between power supply pin, shown in a figure.

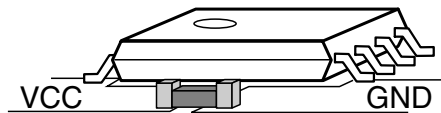

Range of Power Dissipation and Ambient Temperature

Operating condition range (power supply and ambient temperature) which is not exceeded package power dissipation and package junction temperature shown in the item of Absolute Maximum Rating are shown in a figure. However this range is calculated from the package thermal resistance under the mounting conditions which NPC specified, and when mounting conditions differ from this condition, it does not become such.

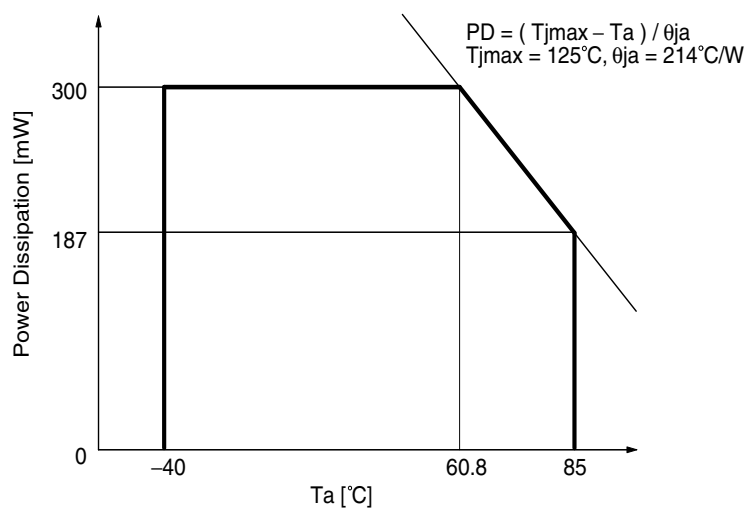

Mounting conditions

- glass epoxy board
- board size: $40\text{mm} \times 40\text{mm}$
- wiring density: 10%
- still air

The following method is effective, in order to lower thermal resistance and to prevent the rise of junction temperature.

- Wiring area connected to the pin of SM5304AV is made widely.
- To cool down, use the cooling fan etc.

Please pay your attention to the following points at time of using the products shown in this document.

The products shown in this document (hereinafter "Products") are not intended to be used for the apparatus that exerts harmful influence on human lives due to the defects, failure or malfunction of the Products. Customers are requested to obtain prior written agreement for such use from SEIKO NPC CORPORATION (hereinafter "NPC"). Customers shall be solely responsible for, and indemnify and hold NPC free and harmless from, any and all claims, damages, losses, expenses or lawsuits, due to such use without such agreement. NPC reserves the right to change the specifications of the Products in order to improve the characteristic or reliability thereof. NPC makes no claim or warranty that the contents described in this document dose not infringe any intellectual property right or other similar right owned by third parties. Therefore, NPC shall not be responsible for such problems, even if the use is in accordance with the descriptions provided in this document. Any descriptions including applications, circuits, and the parameters of the Products in this document are for reference to use the Products, and shall not be guaranteed free from defect, inapplicability to the design for the mass-production products without further testing or modification. Customers are requested not to export or re-export, directly or indirectly, the Products to any country or any entity not in compliance with or in violation of the national export administration laws, treaties, orders and regulations. Customers are requested appropriately take steps to obtain required permissions or approvals from appropriate government agencies.

The logo for NPC (Seiko NPC Corporation) consists of the letters 'NPC' in a bold, stylized, sans-serif font. The 'N' and 'P' are connected at the top, and the 'C' is a simple, rounded shape.

SEIKO NPC CORPORATION

15-6, Nihombashi-kabutocho, Chuo-ku,
Tokyo 103-0026, Japan
Telephone: +81-3-6667-6601
Facsimile: +81-3-6667-6611
<http://www.npc.co.jp/>
Email: sales@npc.co.jp

NC0118BE 2006.04