

## OVERVIEW

The SM5021 series are crystal oscillator module ICs fabricated in NPC's Molybdenum-gate CMOS, that incorporate high-frequency, low current consumption oscillator and output buffer circuits. Highly

accurate thin-film feedback resistors and high-frequency capacitors are built-in, eliminating the need for external components to make a stable 3rd-harmonic oscillator.

## FEATURES

- 3rd overtone oscillation
- Capacitors CG, CD built-in
- Inverter amplifier feedback resistor built-in (A×, B× series)
- TTL input level
- 4 mA ( $V_{DD} = 2.7$  V) drive capability  
8 mA ( $V_{DD} = 4.5$  V) drive capability
- Output three-state function
- 2.7 to 5.5 V supply voltage (A×, K× series)  
4.5 to 5.5 V supply voltage (B×, L× series)
- Oscillator frequency output
- 6-pin SOT (SM5021××H)
- Chip form (CF5021××)

## SERIES CONFIGURATION

Version <sup>1</sup>	Supply voltage		Recommended operating frequency range (MHz)		Built-in capacitance (pF)		gm ratio	Rf (kΩ)	Output frequency	Output level	Standby output state
	Chip	SOT	3V	5V	C <sub>G</sub>	C <sub>D</sub>					
SM5021AAH	4.5 to 5.5	4.5 to 5.5	×	22 to 30	8	15	1	6.0	fo	CMOS	High impedance
SM5021ABH	2.7 to 5.5	2.7 to 5.5	22 to 30	30 to 43	8	15	1	3.3	fo	CMOS	High impedance
SM5021ACH	2.7 to 5.5	2.7 to 5.5	30 to 40	43 to 55	8	15	2	3.9	fo	CMOS	High impedance
SM5021ADH	2.7 to 5.5	2.7 to 5.5	40 to 50	55 to 70	8	15	3	2.7	fo	CMOS	High impedance
SM5021AEH	2.7 to 3.6	×	50 to 70	×	8	12	4	2.7	fo	CMOS	High impedance
SM5021BAH	4.5 to 5.5	4.5 to 5.5	×	22 to 30	8	15	1	6.0	fo	TTL	High impedance
SM5021BBH	4.5 to 5.5	4.5 to 5.5	×	30 to 43	8	15	1	3.3	fo	TTL	High impedance
SM5021BCH	4.5 to 5.5	4.5 to 5.5	×	43 to 55	8	15	2	3.9	fo	TTL	High impedance
SM5021BDH	4.5 to 5.5	4.5 to 5.5	×	55 to 70	8	15	3	2.7	fo	TTL	High impedance
SM5021KDH	2.7 to 5.5	2.7 to 5.5	22 to 50	22 to 70	8	15	3	–	fo	CMOS	High impedance
SM5021KEH	2.7 to 3.6	2.7 to 3.6	50 to 70	×	8	12	4	–	fo	CMOS	High impedance
SM5021LDH	4.5 to 5.5	4.5 to 5.5	×	22 to 70	8	15	3	–	fo	TTL	High impedance

1. Chip form devices have designation CF5021××.

## ORDERING INFORMATION

Devicez	Package
SM5021××H	6-pin SOT
CF5021××-2	Chip form

**PACKAGE DIMENSIONS**

(UNIT : mm)

- 6-pin SOT

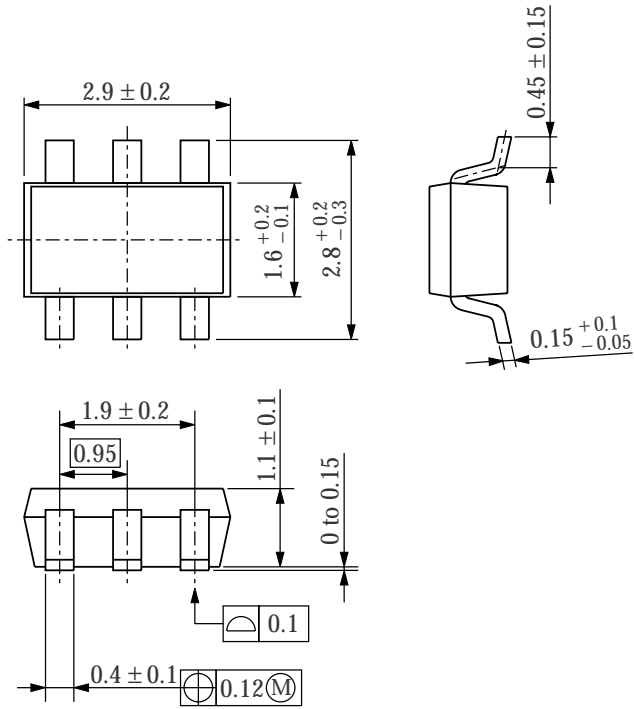

**PAD LAYOUT**

(Unit :  $\mu\text{m}$ )

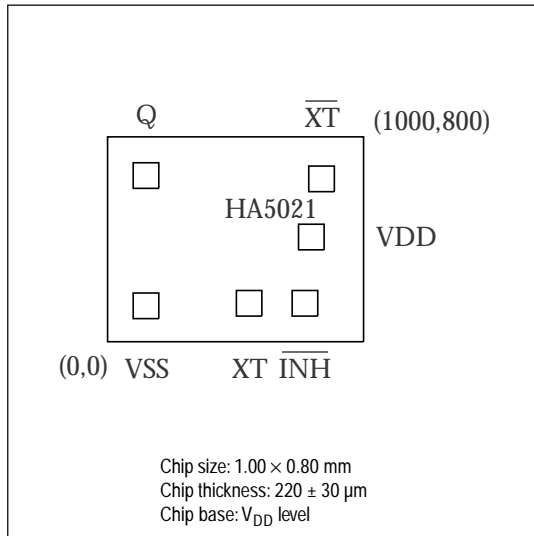

**PINOUT**

(Top View)

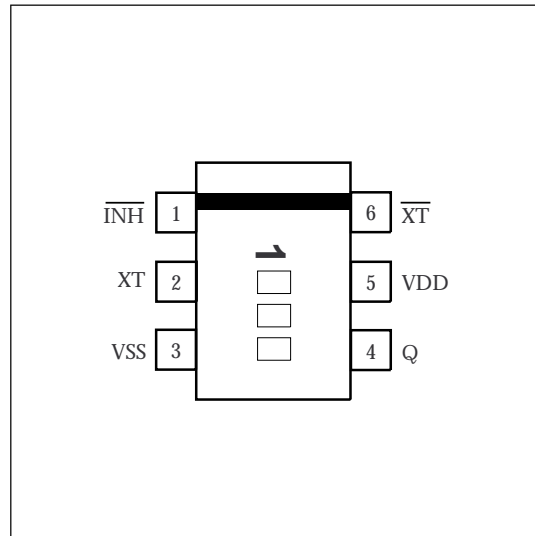

**PIN DESCRIPTION and PAD DIMENSIONS**

Number	Name	I/O	Description	Pad dimensions [ $\mu\text{m}$ ]	
				X	Y
1	$\overline{\text{INH}}$	I	Output state control input. High impedance when LOW. Pull-up resistor built in	771	150
2	XT	I	Amplifier input. Crystal oscillator connection pins. Crystal oscillator connected between XT and $\overline{\text{XT}}$	553	150
3	VSS	-	Ground	150	140
4	Q	O	Output. Output frequency ( $f_O$ )	150	649
5	VDD	-	Supply voltage	796	409
6	$\overline{\text{XT}}$	O	Amplifier output. Crystal oscillator connection pins. Crystal oscillator connected between XT and $\overline{\text{XT}}$	836	636

**BLOCK DIAGRAM**

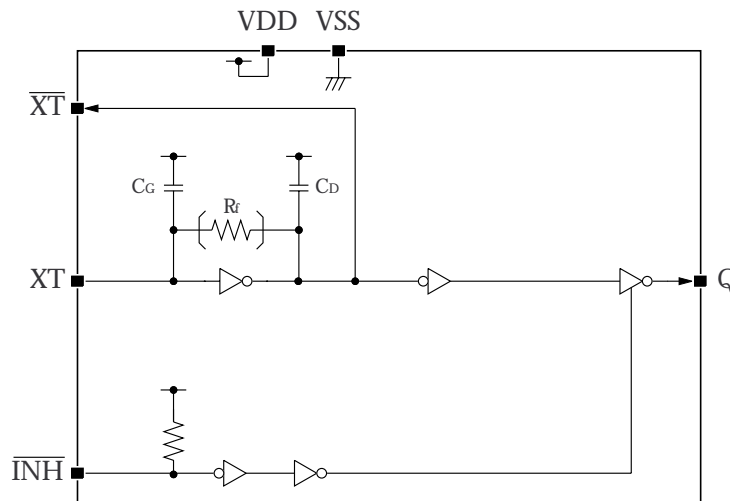

## SPECIFICATIONS

### Absolute Maximum Ratings

$V_{SS} = 0\text{ V}$

Parameter	Symbol	Condition	Rating	Unit
Supply voltage range	$V_{DD}$		-0.5 to 7.0	V
Input voltage range	$V_{IN}$		-0.5 to $V_{DD} + 0.5$	V
Output voltage range	$V_{OUT}$		-0.5 to $V_{DD} + 0.5$	V
Operating temperature range	$T_{opr}$		-40 to 85	°C
Storage temperature range	$T_{stg}$	Chip form	-65 to 150	°C
		6-pin SOT	-55 to 125	
Output current	$I_{OUT}$		13	mA
Power dissipation	$P_D$	6-pin SOT	250	mW

### Recommended Operating Conditions

$V_{SS} = 0\text{ V}$ ,  $f \leq 70\text{ MHz}$ ,  $C_L \leq 15\text{ pF}$

Parameter	Symbol	Condition	Rating			Unit
			min	typ	max	
Supply voltage	$V_{DD}$		2.7	-	5.5	V
Input voltage	$V_{IN}$		$V_{SS}$	-	$V_{DD}$	V
Operating temperature	$T_{OPR}$		-20	-	80	°C

Note: Recommended operating conditions will change in accordance with operating frequency, load capacitance, or power dissipation.

## Electrical Characteristics

3 V operation: AA, AB, AC, AD, AE series/ KD, KE series

$V_{DD} = 2.7$  to  $3.6$  V,  $V_{SS} = 0$  V,  $T_a = -20$  to  $80$  °C unless otherwise noted.

Parameter	Symbol	Condition	Rating			Unit	
			min	typ	max		
HIGH-level output voltage	$V_{OH}$	Q: Measurement cct 1, $V_{DD} = 2.7$ V, $I_{OH} = 4$ mA	2.1	2.4	-	V	
		Q: Measurement cct 1, $V_{DD} = 2.7$ V, $I_{OH} = 8$ mA					
LOW-level output voltage	$V_{OL}$	Q: Measurement cct 2, $V_{DD} = 2.7$ V, $I_{OL} = 4$ mA	-	0.3	0.4	V	
		Q: Measurement cct 2, $V_{DD} = 2.7$ V, $I_{OL} = 8$ mA					
Output leakage current	$I_Z$	Q: Measurement cct 2, $V_{DD} = 3.3$ V, $\overline{INH} = LOW$ , $V_{OH} = V_{DD}$	-	-	10	$\mu A$	
		Q: Measurement cct 2, $V_{DD} = 3.3$ V, $\overline{INH} = LOW$ , $V_{OL} = V_{SS}$	-	-	10		
HIGH-level input voltage	$V_{IH}$	$\overline{INH}$	2.0	-	-	V	
LOW-level input voltage	$V_{IL}$	$\overline{INH}$	-	-	0.5	V	
Current consumption	$I_{DD}$	$\overline{INH} = open$ , Measurement cct 3, load cct 1, $C_L = 15$ pF, 70 MHz crystal oscillator	-	13	25	mA	
$\overline{INH}$ pull-up resistance	$R_{UP}$	Measurement cct 4	25	100	250	k $\Omega$	
Feedback resistance (A $\times$ series only)	$R_f$	Measurement cct 5	SM5021 $\times$ AH, CF5021 $\times$ A	5.1	6.0	6.9	k $\Omega$
			SM5021 $\times$ BH, CF5021 $\times$ B	2.8	3.3	3.8	
			SM5021 $\times$ CH, CF5021 $\times$ C	3.3	3.9	4.5	
			SM5021 $\times$ DH, CF5021 $\times$ D SM5021 $\times$ EH, CF5021 $\times$ E	2.3	2.7	3.1	
Built-in capacitance	$C_G$	Design value, determined by the internal wafer pattern	7.44	8	8.56	pF	
	$C_D$	Design value, determined by the internal wafer pattern	13.95	15	16.05	pF	
		SM5021 $\times$ AH, CF5021 $\times$ A SM5021 $\times$ BH, CF5021 $\times$ B SM5021 $\times$ CH, CF5021 $\times$ C SM5021 $\times$ DH, CF5021 $\times$ D SM5021 $\times$ EH, CF5021 $\times$ E	11.16	12	12.84		

SM5021 series

5 V operation: AA, AB, AC, AD series/ BA, BB, BC, BD series/ KD series/ LD series

$V_{DD} = 4.5$  to  $5.5$  V,  $V_{SS} = 0$  V,  $T_a = -20$  to  $80$  °C unless otherwise noted.

Parameter	Symbol	Condition	Rating			Unit	
			min	typ	max		
HIGH-level output voltage	$V_{OH}$	Q: Measurement cct 1, $V_{DD} = 4.5$ V, $I_{OH} = 8$ mA	3.9	4.2	–	V	
LOW-level output voltage	$V_{OL}$	Q: Measurement cct 2, $V_{DD} = 4.5$ V, $I_{OL} = 8$ mA	–	0.3	0.4	V	
Output leakage current	$I_Z$	Q: Measurement cct 2, $V_{DD} = 5.5$ V, $\overline{INH} = LOW$ , $V_{OH} = V_{DD}$	–	–	10	$\mu$ A	
		Q: Measurement cct 2, $V_{DD} = 5.5$ V, $\overline{INH} = LOW$ , $V_{OL} = V_{SS}$	–	–	10		
HIGH-level input voltage	$V_{IH}$	$\overline{INH}$	2.0	–	–	V	
LOW-level input voltage	$V_{IL}$	$\overline{INH}$	–	–	0.8	V	
Current consumption	$I_{DD}$	$\overline{INH} = open$ , Measurement cct 3, load cct 1, $C_L = 15$ pF, 70 MHz crystal oscillator	–	18	35	mA	
		$\overline{INH} = open$ , Measurement cct 3, load cct 2, $C_L = 15$ pF, 70 MHz crystal oscillator	–	18	35		
$\overline{INH}$ pull-up resistance	$R_{UP}$	Measurement cct 4	25	100	250	k $\Omega$	
Feedback resistance (A $\times$ , B $\times$ series only)	$R_f$	Measurement cct 5	SM5021 $\times$ AH, CF5021 $\times$ A	5.1	6.0	6.9	k $\Omega$
			SM5021 $\times$ BH, CF5021 $\times$ B	2.8	3.3	3.8	
			SM5021 $\times$ CH, CF5021 $\times$ C	3.3	3.9	4.5	
			SM5021 $\times$ DH, CF5021 $\times$ D	2.3	2.7	3.1	
Built-in capacitance	$C_G$	Design value, determined by the internal wafer pattern	SM5021 $\times$ AH, CF5021 $\times$ A	7.44	8	8.56	pF
	$C_D$		SM5021 $\times$ BH, CF5021 $\times$ B SM5021 $\times$ CH, CF5021 $\times$ C SM5021 $\times$ DH, CF5021 $\times$ D	13.95	15	16.05	pF

## Switching Characteristics

### CMOS

3 V operation: AA, AB, AC, AD, AE series/ KD, KE series

$V_{DD} = 2.7$  to  $3.6$  V,  $V_{SS} = 0$  V,  $T_a = -20$  to  $80$  °C unless otherwise noted.

Parameter	Symbol	Condition	Rating			Unit	
			min	typ	max		
Output rise time	$t_{r1}$	Measurement cct 6, load cct 1, $0.1V_{DD}$ to $0.9V_{DD}$ , $C_L = 15$ pF	SM5021AAH, CF5021AA SM5021ABH, CF5021AB SM5021ACH, CF5021AC SM5021ADH, CF5021AD SM5021KDH, CF5021KD	–	5	10	ns
			SM5021AEH, CF5021AE SM5021KEH, CF5021KE	–	3.5	7	
	Measurement cct 6, load cct 1, $0.2V_{DD}$ to $0.8V_{DD}$ , $C_L = 15$ pF	SM5021AAH, CF5021AA SM5021ABH, CF5021AB SM5021ACH, CF5021AC SM5021ADH, CF5021AD SM5021KDH, CF5021KD	–	3.5	7		
Output fall time	$t_{f1}$	Measurement cct 6, load cct 1, $0.9V_{DD}$ to $0.1V_{DD}$ , $C_L = 15$ pF	SM5021AAH, CF5021AA SM5021ABH, CF5021AB SM5021ACH, CF5021AC SM5021ADH, CF5021AD SM5021KDH, CF5021KD	–	5	10	ns
			SM5021AEH, CF5021AE SM5021KEH, CF5021KE	–	3.5	7	
	Measurement cct 6, load cct 1, $0.8V_{DD}$ to $0.2V_{DD}$ , $C_L = 15$ pF	SM5021AAH, CF5021AA SM5021ABH, CF5021AB SM5021ACH, CF5021AC SM5021ADH, CF5021AD SM5021KDH, CF5021KD	–	3.5	7		
Output duty cycle <sup>1</sup>	Duty	Measurement cct 6, load cct 1, $T_a = 25$ °C, $V_{DD} = 3$ V, $C_L = 15$ pF, $f \leq 70$ MHz	45	–	55	%	
Output disable delay time	$t_{PLZ}$	Measurement cct 6, load cct 1, $T_a = 25$ °C, $V_{DD} = 3$ V, $C_L = 15$ pF	–	–	100	ns	
Output enable delay time	$t_{PZL}$		–	–	100	ns	

1. Determined by the lot monitor.

5 V operation: AA, AB, AC, AD series/ KD series

$V_{DD} = 4.5$  to  $5.5$  V,  $V_{SS} = 0$  V,  $T_a = -20$  to  $80$  °C unless otherwise noted.

Parameter	Symbol	Condition	Rating			Unit
			min	typ	max	
Output rise time	$t_{r1}$	Measurement cct 6, load cct 1, $0.1V_{DD}$ to $0.9V_{DD}$ , $C_L = 15$ pF	–	3.5	7	ns
Output fall time	$t_{f1}$	Measurement cct 6, load cct 1, $0.9V_{DD}$ to $0.1V_{DD}$ , $C_L = 15$ pF	–	3.5	7	ns
Output duty cycle <sup>1</sup>	Duty	Measurement cct 6, load cct 1, $T_a = 25$ °C, $V_{DD} = 5$ V, $C_L = 15$ pF, $f \leq 70$ MHz	45	–	55	%
Output disable delay time	$t_{PLZ}$	Measurement cct 6, load cct 1, $T_a = 25$ °C, $V_{DD} = 5$ V, $C_L = 15$ pF	–	–	100	ns
Output enable delay time	$t_{PZL}$		–	–	100	ns

1. Determined by the lot monitor.

**TTL**

5 V operation: BA, BB, BC, BD series/ LD series

$V_{DD} = 4.5$  to  $5.5$  V,  $V_{SS} = 0$  V,  $T_a = -20$  to  $80$  °C unless otherwise noted.

Parameter	Symbol	Condition	Rating			Unit
			min	typ	max	
Output rise time	$t_{r2}$	Measurement cct 6, load cct 2, 0.4V to 2.4V, $C_L = 15$ pF	-	2.5	7	ns
Output fall time	$t_{f2}$	Measurement cct 6, load cct 2, 2.4V to 0.4V, $C_L = 15$ pF	-	2.5	7	ns
Output duty cycle <sup>1</sup>	Duty	Measurement cct 6, load cct 2, $T_a = 25$ °C, $V_{DD} = 5$ V, $C_L = 15$ pF, $f \leq 70$ MHz	45	-	55	%
Output disable delay time	$t_{pLZ}$	Measurement cct 6, load cct 2, $T_a = 25$ °C, $V_{DD} = 5$ V, $C_L = 15$ pF	-	-	100	ns
Output enable delay time	$t_{pZL}$		-	-	100	ns

1. Determined by the lot monitor.

**Current consumption and Output waveform with NPC's standard crystal**

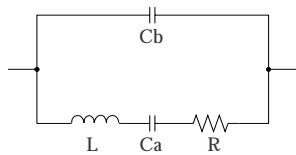

f (MHz)	R (Ω)	L (mH)	Ca (fF)	Cb (pF)
30	18.62	16.24	1.733	5.337
40	20.53	11.34	1.396	3.989
50	22.17	7.40	1.370	4.105
60	22.20	5.05	1.388	4.226
70	25.42	4.18	1.254	5.170

**FUNCTIONAL DESCRIPTION**

**Standby Function**

When  $\overline{INH}$  goes LOW, the oscillator output on Q goes high impedance.

$\overline{INH}$	Q	Oscillator
HIGH (or open)	$f_O$ output frequency	Normal operation
LOW	High impedance	Normal operation



## MEASUREMENT CIRCUITS

### Measurement cct 1

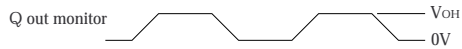
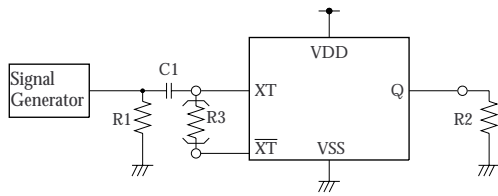

- 2.0V<sub>p-p</sub>, 10MHz sine wave input signal (3V operation)
- 3.5V<sub>p-p</sub>, 10MHz sine wave input signal (5V operation)
- C1 : 0.001μF
- R1 : 50Ω
- R2 : 525Ω (3V operation/ ×A, ×B, ×C, ×D series)  
263Ω (3V operation/ ×E series)
- 490Ω (5V operation)
- R3 : 100kΩ (K×, L× series)

### Measurement cct 4

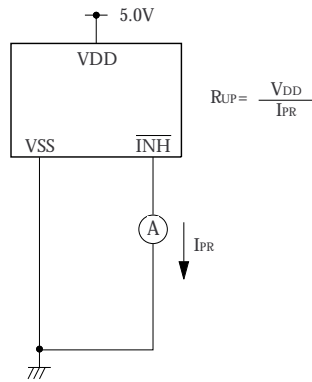

### Measurement cct 2

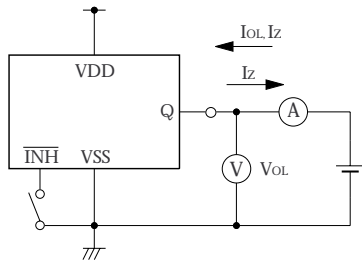

### Measurement cct 5

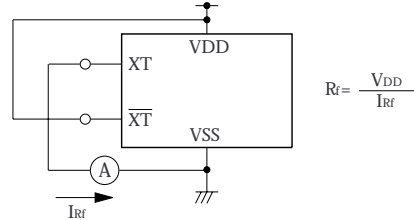

### Measurement cct 3

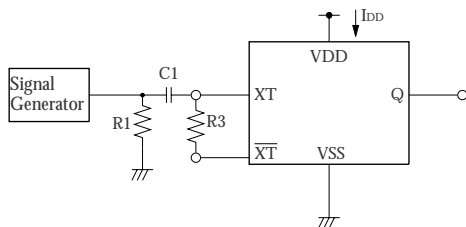

- 2.0V<sub>p-p</sub>, 70MHz sine wave input signal (3V operation)
- 3.5V<sub>p-p</sub>, 70MHz sine wave input signal (5V operation)
- C1 : 0.001μF
- R1 : 50Ω
- R3 : 100kΩ (K×, L× series)

### Measurement cct 6

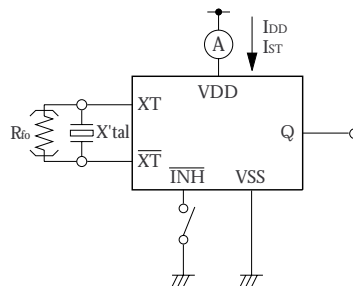

- R<sub>0</sub> : 2.7kΩ (K×, L× series)

**Load cct 1**

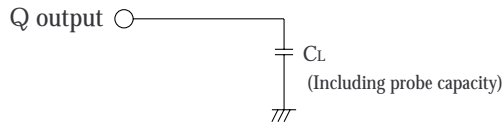

$C_L = 15\text{pF}; t_{r1}, t_{f1}$

**Load cct 2**

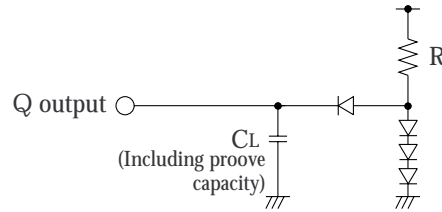

$C_L = 15\text{pF}; t_{r2}, t_{f2}$   
 $R = 800\Omega$

**Switching Time Measurement Waveform**

**Output duty level (CMOS)**

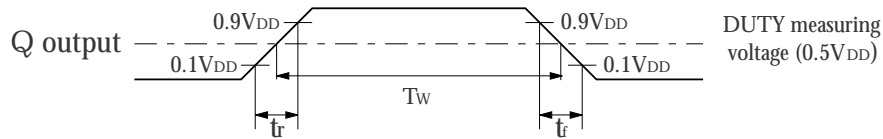

**Output duty level (TTL)**

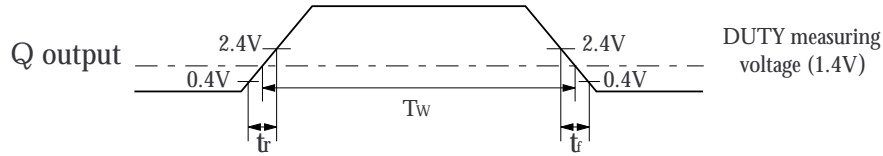

**Output duty cycle (CMOS)**

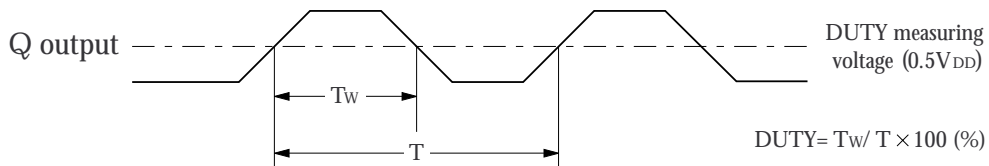

**Output duty cycle (TTL)**

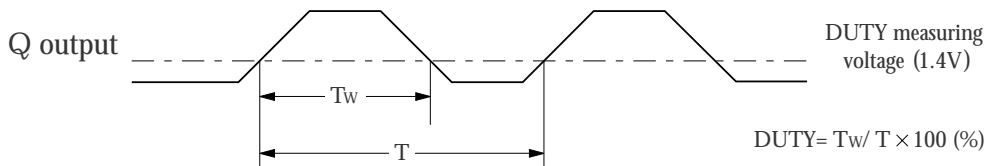

## Output Enable/Disable Delay

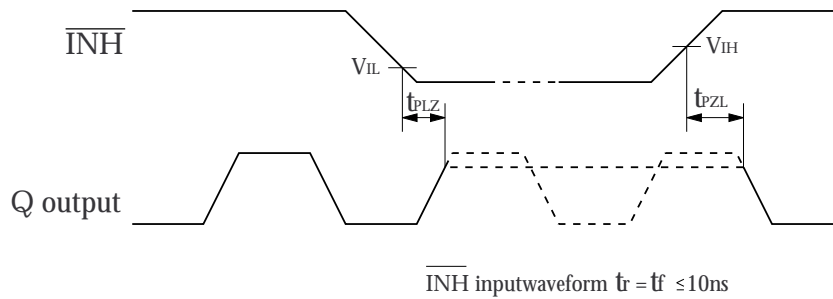

NIPPON PRECISION CIRCUITS INC. reserves the right to make changes to the products described in this data sheet in order to improve the design or performance and to supply the best possible products. Nippon Precision Circuits Inc. assumes no responsibility for the use of any circuits shown in this data sheet, conveys no license under any patent or other rights, and makes no claim that the circuits are free from patent infringement. Applications for any devices shown in this data sheet are for illustration only and Nippon Precision Circuits Inc. makes no claim or warranty that such applications will be suitable for the use specified without further testing or modification. The products described in this data sheet are not intended to use for the apparatus which influence human lives due to the failure or malfunction of the products. Customers are requested to comply with applicable laws and regulations in effect now and hereinafter, including compliance with export controls on the distribution or dissemination of the products. Customers shall not export, directly or indirectly, any products without first obtaining required licenses and approvals from appropriate government agencies.

**NPC**  
NIPPON PRECISION CIRCUITS INC.

NIPPON PRECISION CIRCUITS INC.

4-3, Fukuzumi 2-chome  
Koto-ku, Tokyo 135-8430, Japan  
Telephone: 03-3642-6661  
Facsimile: 03-3642-6698

NC9903AE 1999.11