

OVERVIEW

The SM5003 Series is quartz crystal oscillator ICs fabricated in NPC's Molybdenum-gate CMOS. They comprise low-voltage low-current consumption oscillator circuits

and output buffers. They incorporate built-in oscillation capacitance with superior frequency response to realize without any external components.

FEATURES

- Oscillation frequency up to 70MHz
- 3rd overtone oscillation
- 4.5 to 5.5 V supply voltage
- Inverter amplifier feedback resistance built-in (R_f)
- Oscillation capacitance built-in (C_G and C_D)
- Output drive capability : 8 mA ($V_{DD}=4.5V$)
- Output frequency : f_o (Oscillation frequency)
- Output duty level
SM5003A×H : CMOS
SM5003B×H : TTL
- Input level : TTL
- 3 state function
- Chip form (CF5003××)
- 6 pin SOT (SM5003××H)

DEVICE LIST

Device	Recommended frequency range (MHz)	gm (relative value)	Output duty level	Output (standby)	Internal capacitance		Rf (kΩ)
					C _G (pF)	C _D (pF)	
SM5003AAH	22 to 30	1.0	CMOS	Hi-Z	8	15	6.1
SM5003ABH	30 to 43	1.0	CMOS	Hi-Z	8	15	3.3
SM5003ACH	43 to 55	2.0	CMOS	Hi-Z	8	15	3.9
SM5003ADH	55 to 70	3.0	CMOS	Hi-Z	8	15	2.7
SM5003BAH	22 to 30	1.0	TTL	Hi-Z	8	15	6.1
SM5003BBH	30 to 43	1.0	TTL	Hi-Z	8	15	3.3
SM5003BCH	43 to 55	2.0	TTL	Hi-Z	8	15	3.9
SM5003BDH	55 to 70	3.0	TTL	Hi-Z	8	15	2.7

Notes :

CF5003×× is Chip form.

SM5003××H is 6 pin SOT.

SM5003 Series

PAD DIMENSIONS

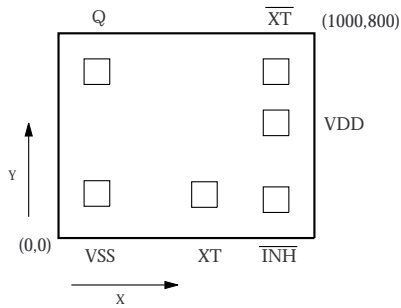

PAD COORDINATES

Name	Coordinates (μm)	
	X	Y
VSS	150	174
XT	570	170
$\overline{\text{INH}}$	850	150
VDD	850	450
$\overline{\text{XT}}$	850	650
Q	150	650

Chip size : 1.00x0.80mm
 Chip thickness : 250±30μm
 Chip reverse side : VDD level

PIN CONFIGURATION (Top View)

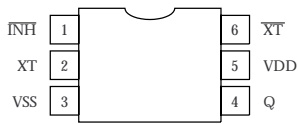

TERMINAL DESCRIPTIONS

Name	Descriptions
XT	Oscillator input pin
$\overline{\text{XT}}$	Oscillator output pin
$\overline{\text{INH}}$	Output state control input pin (with built-in pull-up resistance)
VDD	Supply voltage
VSS	Ground
Q	Output pin (fo:Oscillator frequency output XT pin)

SM5003 Series

PACKAGE DIMENSIONS (6 pin SOT)

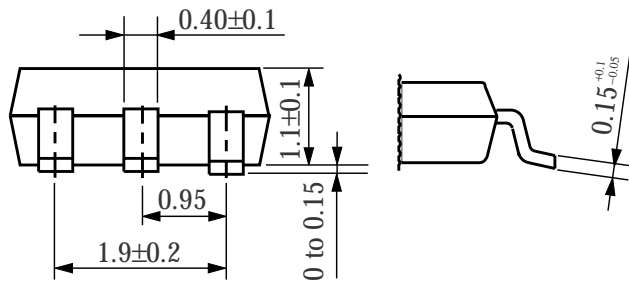
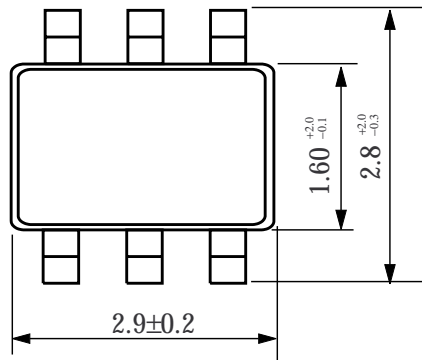

(Unit:mm)

BLOCK DIAGRAM

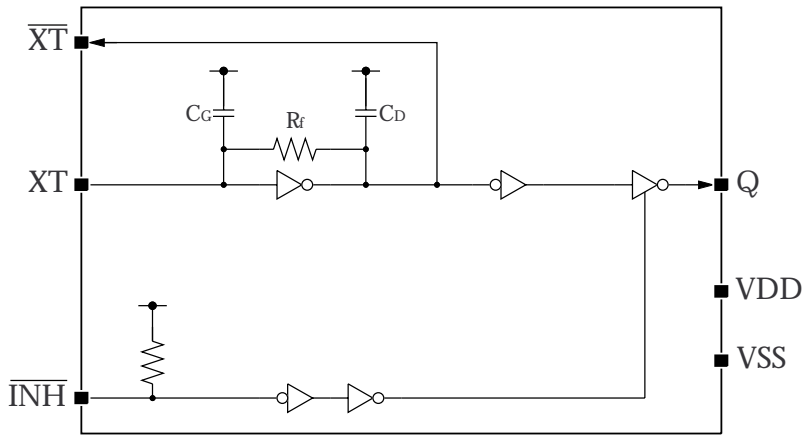

Current consumption and Output waveform with NPC's standard crystal.

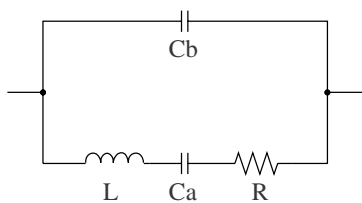

f (MHz)	R (Ω)	L (mH)	C_a (pF)	C_b (pF)
30	18.62	16.24	1.733	5.337
40	20.53	11.34	1.396	3.989
50	22.17	7.40	1.370	4.105
60	22.20	5.05	1.388	4.226
70	25.42	4.18	1.254	5.170

SM5003 Series

SPECIFICATIONS

Absolute Maximum Ratings

(V_{SS} = 0V unless otherwise noted)

Parameter	Symbol	Condition	Rating	Unit
Supply voltage range	V _{DD}		-0.5 to 7.0	V
Input voltage range	V _{IN}		-0.5 to V _{DD} + 0.5	V
Output voltage range	V _{OUT}		-0.5 to V _{DD} + 0.5	V
Storage temperature ranges	T _{STG}	Chip form	-65 to 150	°C
		6 pin SOT	-55 to 125	°C
Power dissipation	P _w	6 pin SOT	250	mW
Output current	I _{OUT}		13	mA
Soldering temperature	T _{SLD}	6 pin SOT	255	°C
Soldering time	t _{SLD}	6 pin SOT	10	sec

Recommended Operating Conditions

(V_{SS} = 0V unless otherwise noted)

Parameter	Symbol	Condition	Limit			Unit
			MIN	TYP	MAX	
Supply Voltage	V _{DD}		4.5		5.5	V
Input voltage	V _{IN}		V _{SS}		V _{DD}	V
Operating temperature	T _{OPR}		-20		+80	°C

Electrical Characteristics

(V_{DD} = 4.5 to 5.5V, V_{SS} = 0V, T_a = -20 to 80°C, unless otherwise noted)

Parameter	Symbol	Condition	Limit			Unit
			MIN	TYP	MAX	
HIGH-level output voltage	V _{OH}	Q pin, test circuit 1, V _{DD} = 4.5V, I _{OH} = 8mA	3.9	4.2		V
LOW-level output voltage	V _{OL}	Q pin, test circuit 2, V _{DD} = 4.5V, I _{OL} = 8mA		0.3	0.4	V
Output leakage current	I _Z	Q pin, test circuit 2, V _{OH} = V _{DD}			10	μA
		$\overline{\text{INH}}$ = Low, V _{DD} = 5.5V, V _{OL} = V _{SS}			10	μA
HIGH-level input voltage	V _{IH}	$\overline{\text{INH}}$ pin	2.0			V
LOW-level input voltage	V _{IL}	$\overline{\text{INH}}$ pin			0.8	V
Current consumption	I _{DD}	$\overline{\text{INH}}$ = OPEN, test circuit 3, C _L = 15pF, f = 70MHz		28	45	mA
		SM5003A×H load circuit 1 SM5003B×H load circuit 2		28	45	mA
Pull-up resistance	R _{UP}	$\overline{\text{INH}}$ pin, test circuit 4	25	100	250	kΩ
AC feedback resistance	R _f	test circuit 5				
		SM5003×AH	5.4	6.1	6.7	kΩ
		SM5003×BH	2.9	3.3	3.7	kΩ
		SM5003×CH	3.5	3.9	4.3	kΩ
Internal capacitance	C _G C _D	Design value, determined by the internal wafer pattern	7.2	8	8.8	pF
			13.5	15	16.5	pF

SM5003 Series

Switching Characteristics

Duty level CMOS (SM5003A×H)

(V_{DD} = 4.5 to 5.5V, V_{SS} = 0V, T_a = -20 to 80°C, unless otherwise noted)

Parameter	Symbol	Conditions	Limit			Unit
			MIN	TYP	MAX	
Output rise time	tr	Test circuit 6, load circuit 1, C_L = 15pF 0.1V _{DD} to 0.9V _{DD}		3.5	7	ns
Output fall time	tr	Test circuit 6, load circuit 1, C_L = 15pF 0.9V _{DD} to 0.1V _{DD}		3.5	7	ns
Output duty cycle	DUTY	Test circuit 6, T_a = 25°C, V_{DD} =5.0V load circuit 1, C_L = 15pF, f= 70MHz (*1)	45		55	%
Output disable delay time	tPLZ	Test circuit 6, T_a = 25°C, V_{DD} = 5.0V load circuit 1, C_L = 15pF			100	ns
Output enable delay time	tPZL				100	ns

Duty level TTL (SM5003B×H)

(V_{DD} = 4.5 to 5.5V, V_{SS} = 0V, T_a = -20 to 80°C, unless otherwise noted)

Parameter	Symbol	Condition	Limit			Unit
			MIN	TYP	MAX	
Output rise time	tr	Test circuit 6, load circuit 2, C_L = 15pF 0.4V _{DD} to 2.4V _{DD}		2.5	7	ns
Output fall time	tr	Test circuit 6, load circuit 2, C_L = 15pF 2.4V _{DD} to 0.4V _{DD}		2.5	7	ns
Output duty cycle	DUTY	Test circuit 6, T_a = 25°C, V_{DD} =5.0V load circuit 2, C_L = 15pF, f= 70MHz (*1)	45		55	%
Output disable delay time	tPLZ	Test circuit 6, T_a = 25°C, V_{DD} = 5.0V load circuit 2, C_L = 15pF			100	ns
Output enable delay time	tPZL				100	ns

Note:

(*1) Determined by the lot. monitor.

TEST CIRCUITS

Test Circuit 1

3.5 V_{P-P}, 10MHz sine wave input signal

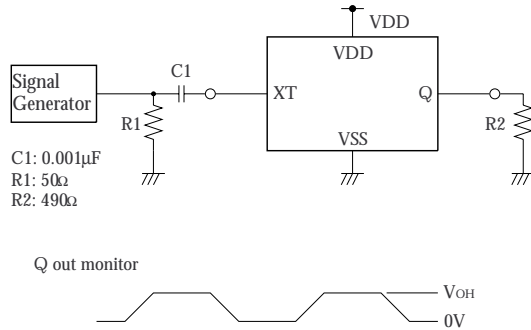

Test Circuit 2

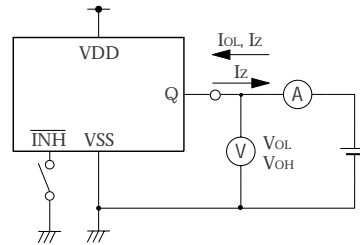

Test Circuit 3

3.5 V_{P-P}, 70MHz sine wave input signal

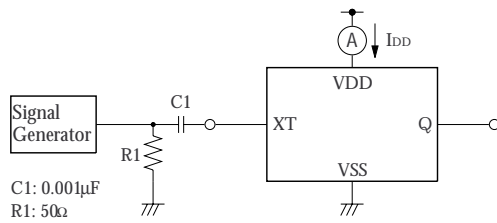

Test Circuit 4

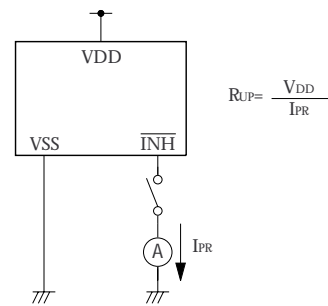

Test Circuit 5

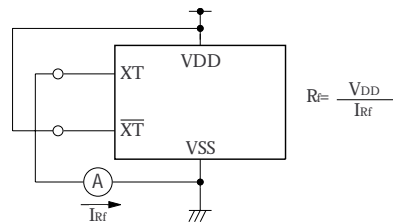

Test Circuit 6

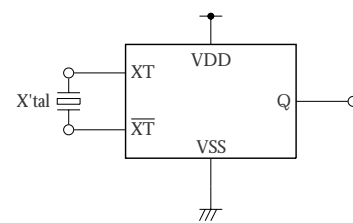

Load Circuit 1

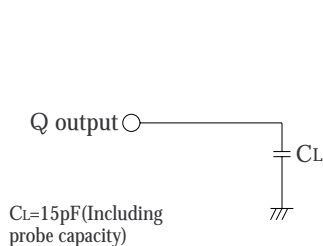

Load Circuit 2

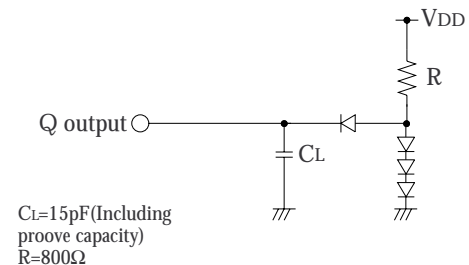

SM5003 Series

Switching Time Test Waveforms

Duty level CMOS (SM5003A×H)

tr,tf DUTY

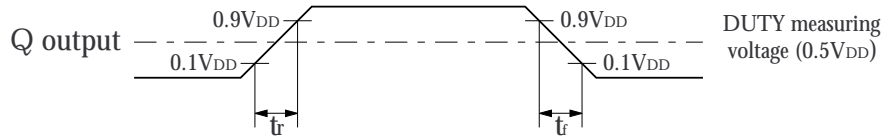

Output duty cycle time

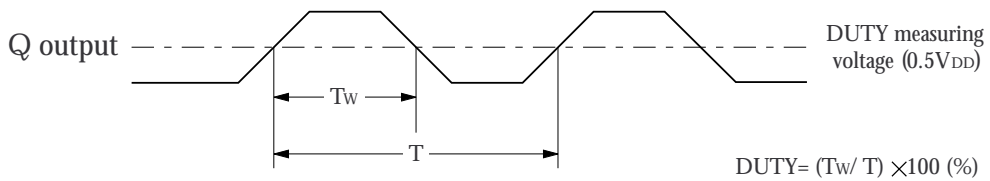

Duty level TTL (SM5003B×H)

tr,tf DUTY

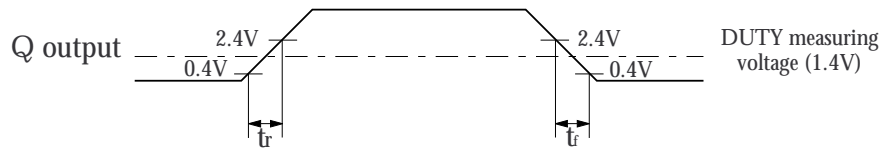

Output duty cycle time

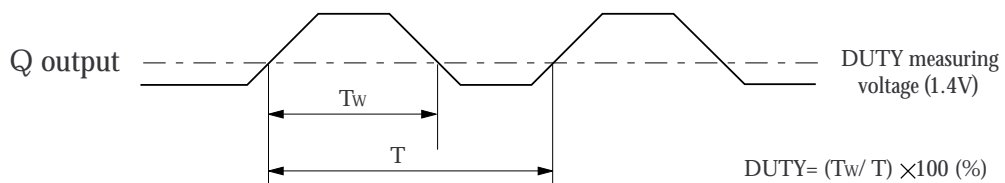

Output Disable/Enable Delay Times

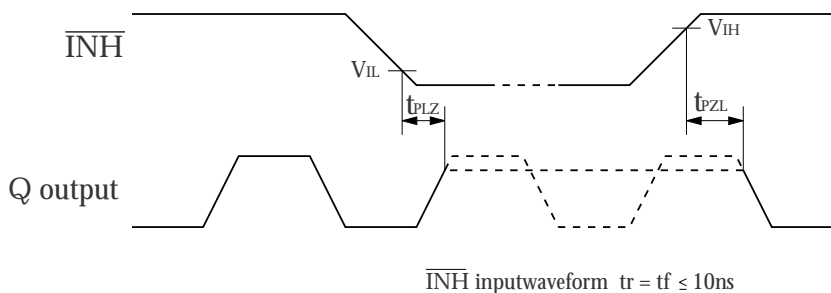

SM5003 Series

NIPPON PRECISION CIRCUITS INC. reserves the right to make changes to the products described in this data sheet in order to improve the design or performance and to supply the best possible products. Nippon Precision Circuits Inc. assumes no responsibility for the use of any circuits shown in this data sheet, conveys no license under any patent or other rights, and makes no claim that the circuits are free from patent infringement. Applications for any devices shown in this data sheet are for illustration only and Nippon Precision Circuits Inc. makes no claim or warranty that such applications will be suitable for the use specified without further testing or modification. The products described in this data sheet are not intended to use for the apparatus which influence human lives due to the failure or malfunction of the products. Customers are requested to comply with applicable laws and regulations in effect now and hereinafter, including compliance with export controls on the distribution or dissemination of the products. Customers shall not export, directly or indirectly, any products without first obtaining required licenses and approvals from appropriate government agencies.



NIPPON PRECISION CIRCUITS INC.

4-3, 2-chome Fukuzumi, Koto-ku
Tokyo, 135 -8430, JAPAN
Telephon: 03-3642-6661
Facsimile: 03-3642-6698

NC9511BE 1996 10

NIPPON PRECISION CIRCUITS-8