

Description

The SL5020 contains two variable gain circuits configured for compressing and expanding the dynamic range of an audio signal. One circuit is configured as an expander, while the other circuit can be configured as a compressor or expander. Each circuit has a full wave rectifier to provide average value information to a variable gain cell located in either the input stage or the feedback path.

An internal temperature stable bandgap reference provides the necessary precision voltages and currents required. It contains also compressor and expander mute circuit.

Features

- Low voltage operation $V_{opr} = 1.8 \sim 5.0V$
- Decreasing external components
- Built in compressor and expander mute circuit
- Unity gain level set a 100mVrms
- Response time adjustable

Ordering Information

Type NO.	Marking	Package Code
SL5020	SL5020	SOP14
SL5020P	SL5020	DIP14

Outline Dimensions

unit : mm

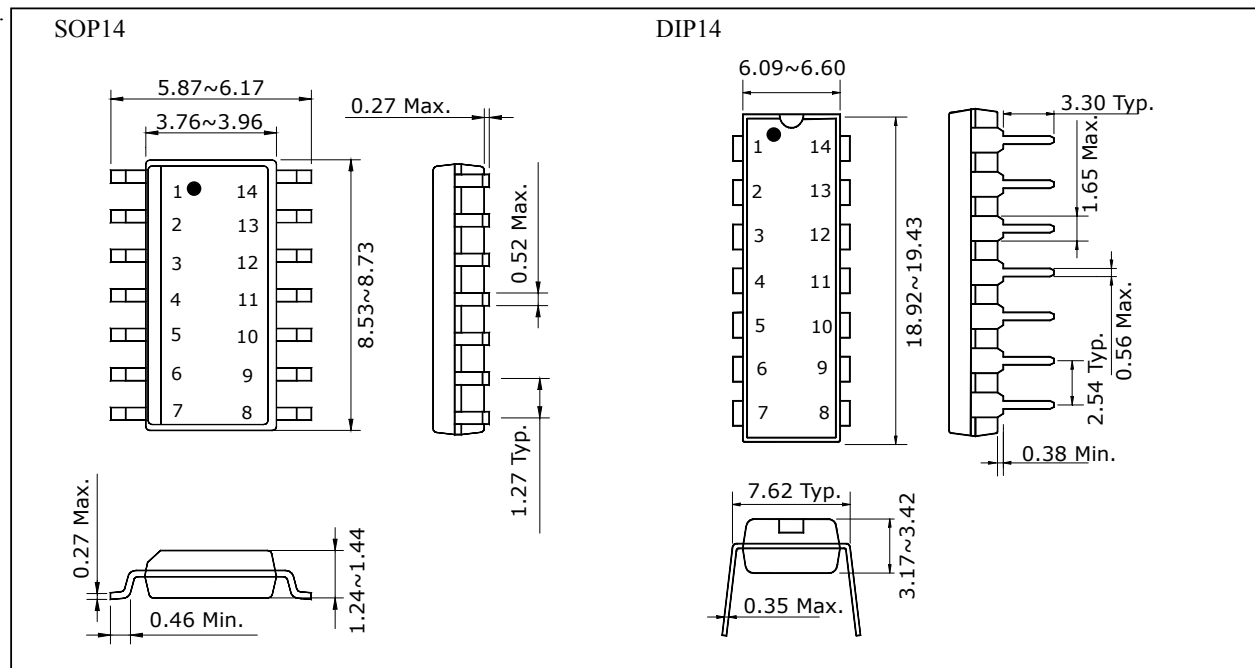

Maximum Ratings(Ta = 25°C)

Characteristics	Symbol	Rating	Unit
Supply Voltage	V _{CC}	10	V
Power Dissipation	P _D	410	mW
Storage Temperature Range	T _{stg}	-55 ~ 150	°C

Operating Conditions

- Operating Supply Voltage : 1.8 ~ 5.0V
- Operating Temperature Range : -20 ~ 70°C
- Input frequency Range : 100Hz ~ 20kHz
- Input Voltage : Compressor Input = 700mVrms
(V_{cc}=3V) Expander Input = 316mVrms

Block Diagram

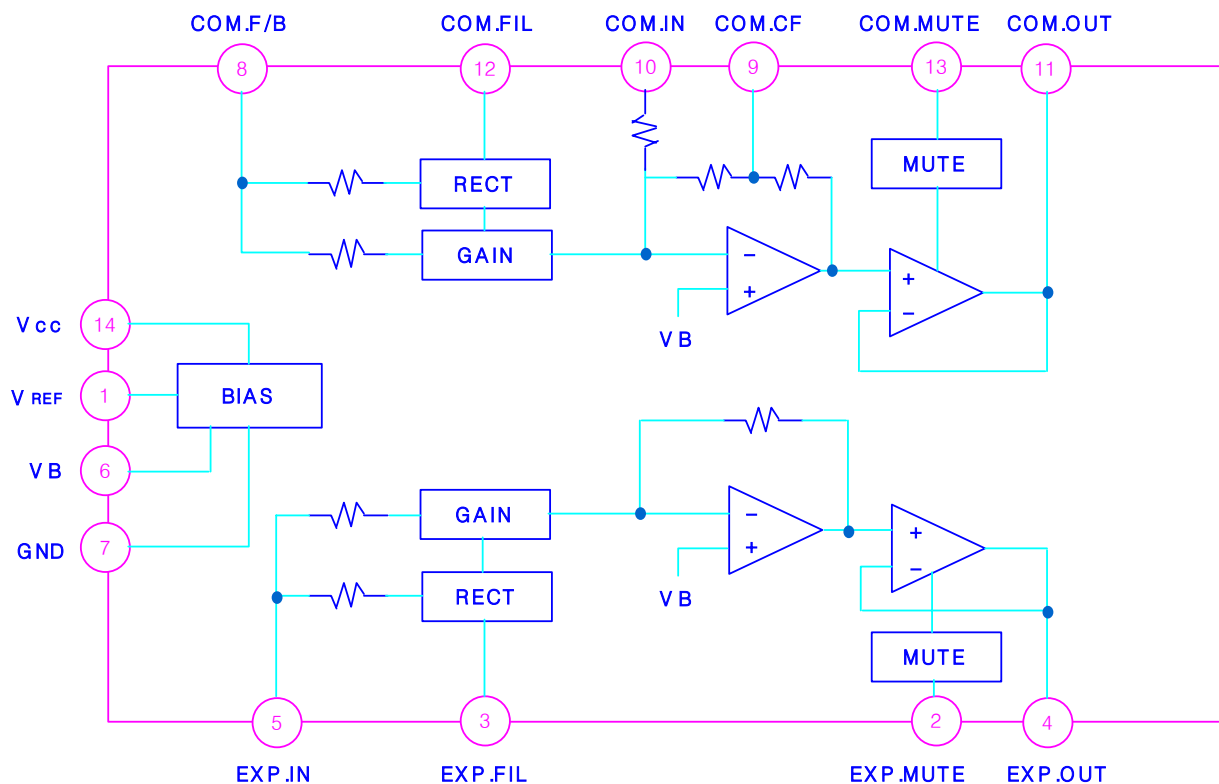

PIN Voltage and Description

Pin		Voltage (V)	Description
No	Name		
1	V _{REF}	1.3	Bandgap Voltage
2	EXP.MUTE	1.4	Expander mute adjust.
3	EXP.FILTER	0 ~ 0.6	Expander Filter. connect to an external capacitor to filter the full wave rectifier's output. This capacitor affects attack & delay times, as well as low frequency accuracy.
4	EXP.OUTPUT	1.5	Output of the expander amplifier
5	EXP.INPUT	1.5	Expander input. Nominally signal range is 3.16mVrms to 316mVrms. Must be capacitor coupled to the signal source
6	VB	2.2	An internal reference voltage. This is an AC ground, and must be well filtered to obtain high power supply rejection and low crosstalk.
7	GND	GND	Ground
8	COM.FEEDBACK	1.5	Input to the compressor Variable gain stage and rectifier.
9	COM.CF	1.5	Normally, this is connected to the compressor's output through filtered DC feedback path.
10	COM.INPUT	1.5	Compressor input, Normally. Signal range is 100uVrms to 1.0Vrms. Must be capacitor coupled to the signal source
11	COM.OUTPUT	1.5	Output of the compressor amplifier.
12	COM.FILTER	0~0.6	Compressor filter. Connect to an external capacitor to filter the full wave rectifier's output. This Capacitor affects attack & decay times, and low frequency accuracy
13	COM.MUTE	1.4	Compressor mute adjust.
14	Vcc	3	Power supply pin. Connect to power supply providing between 1.8 and 5.0 V

Electrical Characteristics

(Unless Otherwise Specified, Ta=25 °C , Vcc=3V, f=1kHz)

Characteristics	Symbol	Test Conditions	Min.	Typ.	Max.	Unit
Supply current	I _{cc}	No Signal	-	3.1	-	mA
Compressor Section						
0 dB Gain	G _{C0}	V _{inc} = 100mVrms, 0dB	-1.5	0	1.5	dB
Gain Error (Note 1)	G _{C1}	V _{inc} = 316mVrms, 10dB	-1	0	1	dB
	G _{C2}	V _{inc} = 10mVrms, -20dB	-1	0	1	dB
	G _{C3}	V _{inc} = 1mVrms, -40dB	-1	0	1	dB
	G _{C4}	V _{inc} = 100uVrms, -60dB	-1	0	1	dB
Distortion	THD _c	V _{inc} =100mVrms, f=1kHz		0.3	1.5	%
Noise Output	V _{noc}	R _g = 600Ω	-	0.8	5.0	mVrms
Ripple Rejection Ratio	RRC	V _{cc} = 1kHz, 3V(DC), 100mVrms	-	-25	-18	dB

Electrical Characteristics(continued)

(Unless Otherwise Specified, Ta=25 °C , Vcc=3V, f=1kHz)

Characteristics	Symbol	Test Conditions	Min.	Typ.	Max.	Unit
Crosstalk(C→E)	CTc	Vinc=100mVrms. Exp Output	-	-72	-50	dB
Muting Attenuation	Attc	Vinc=100mVrms. Vpin13=GND	-	-65	-50	dB
Input Impedance	Rinc	PIN 10	-	20	-	kΩ
Expander Section						
0 dB Gain	Ge0	Vine=100mVrms 0dB	-1.5	0	1.5	dB
Gain Error (Note 1)	Ge ₁	Vine=178mVrms 5dB	-1	0	1	dB
	Ge ₂	Vine=31.6mVrms -10dB	-1	0	1	dB
	Ge ₃	Vine=10mVrms -20dB	-1	0	1	dB
	Ge ₄	Vine=3.16mVrms -30dB	-1	0	1	dB
Distortion	THDe	Vine=100mVrms f=1kHz	-	0.4	1.5	%
Noise Output	Vnoe	Rg = 600Ω	-	0.06	5.0	mVrms
Ripple Rejection Ratio	RRe	Vcc=1kHz, 3V(DC), 100mVrms	-	-58	-38	dB
Crosstalk(E→C)	CTe	Vine=100mVrms, Com Output	-	-34	-24	dB
Muting Attenuation	Atte	Vine=316mVrms, Vpin2=GND	-	-70	-50	dB
Input Impedance	Rine	PIN4	-	4.3	-	kΩ

(Note 1) Gain Error=(V_{OUT} - 20dB) -V_{IN} x K

K : Compressor = 0.5

Expander = 2

Test Circuit

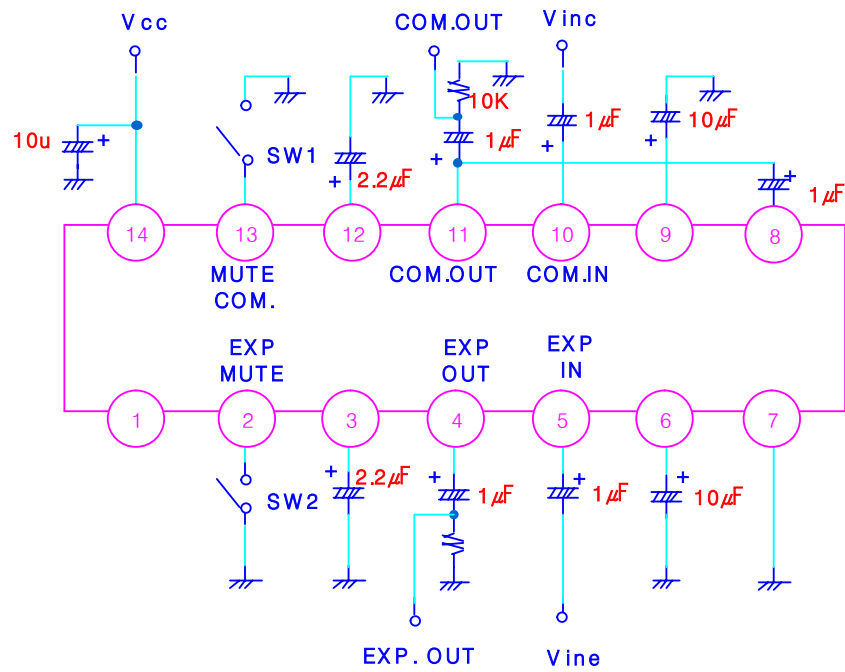

Application Circuit

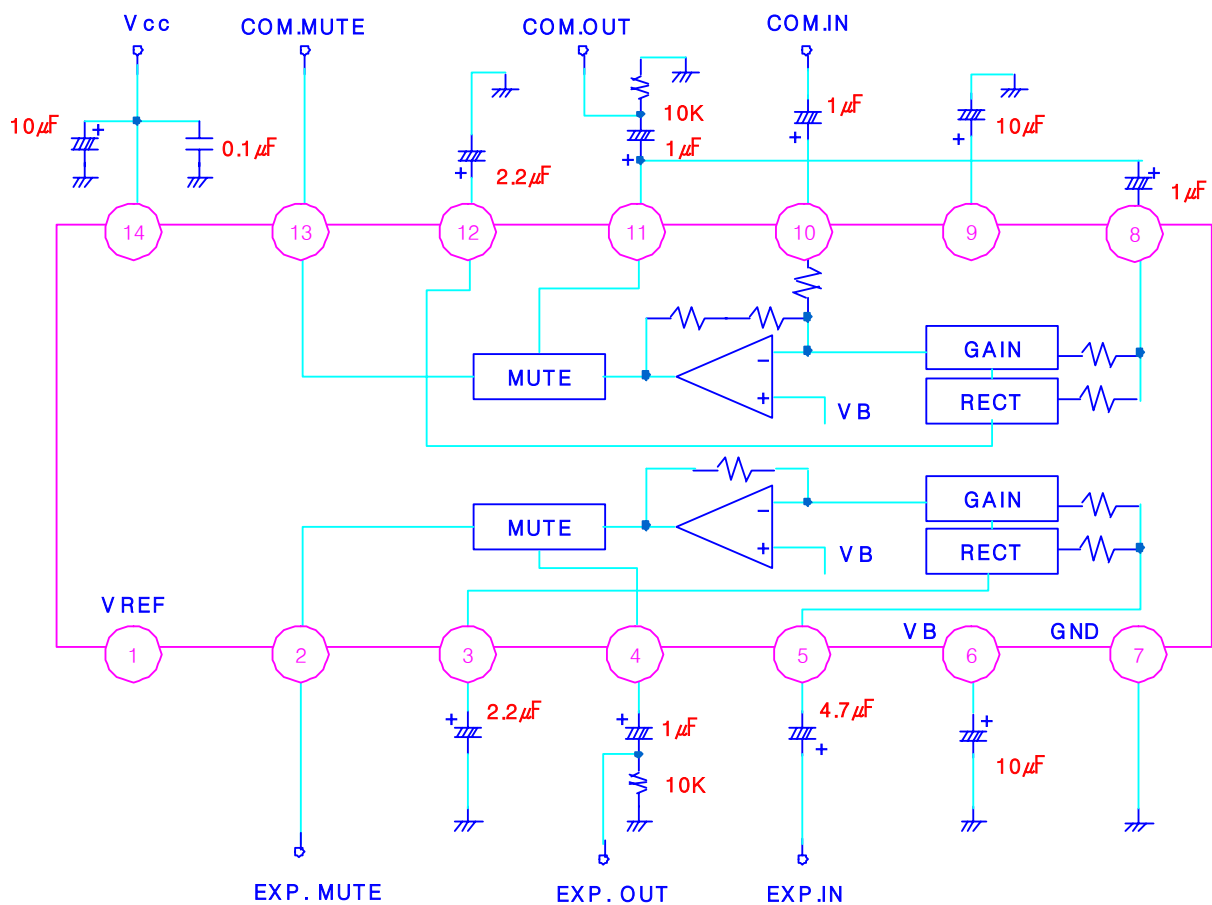

Typical Performance Characteristics

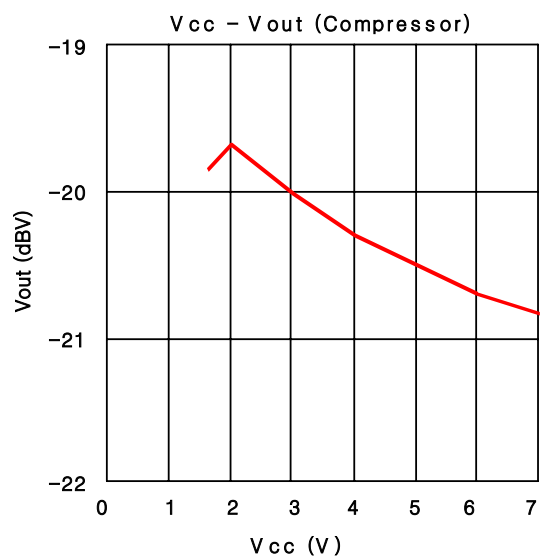
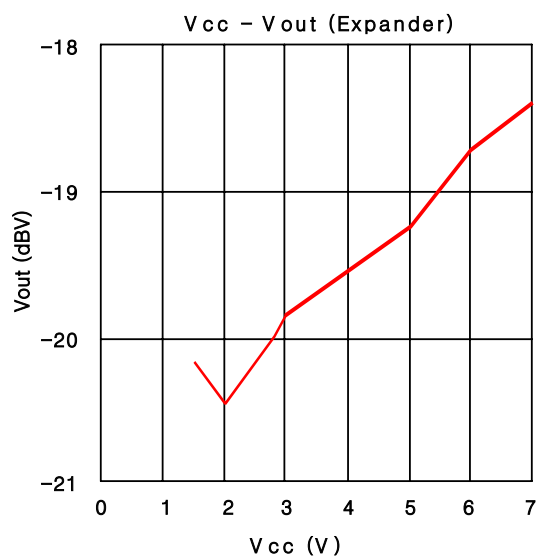
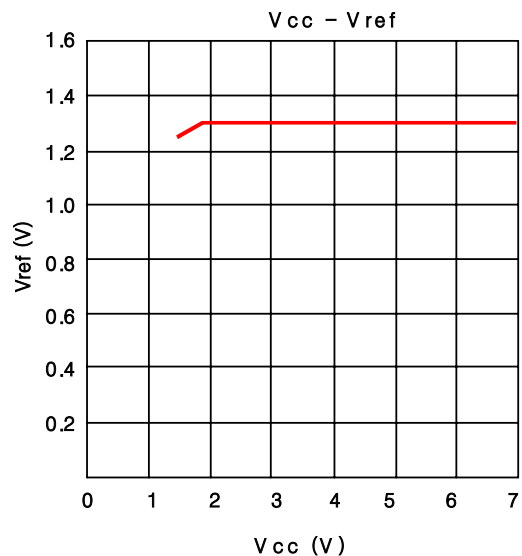
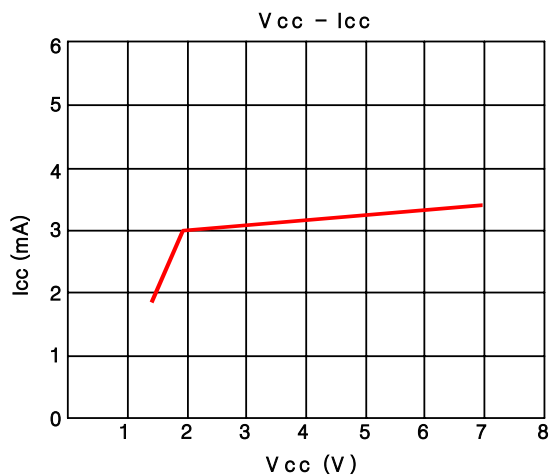

Typical Performance Characteristics(continued)

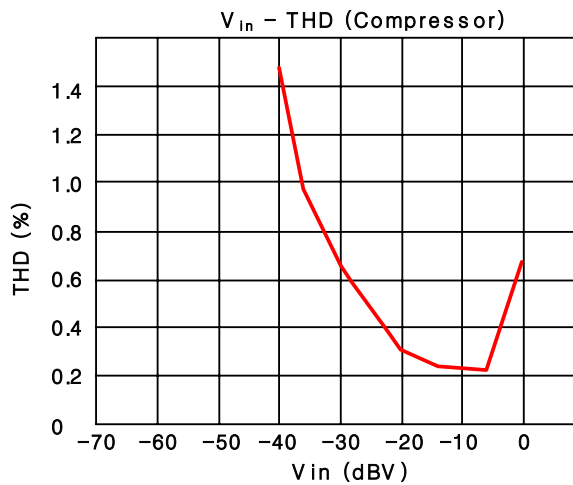
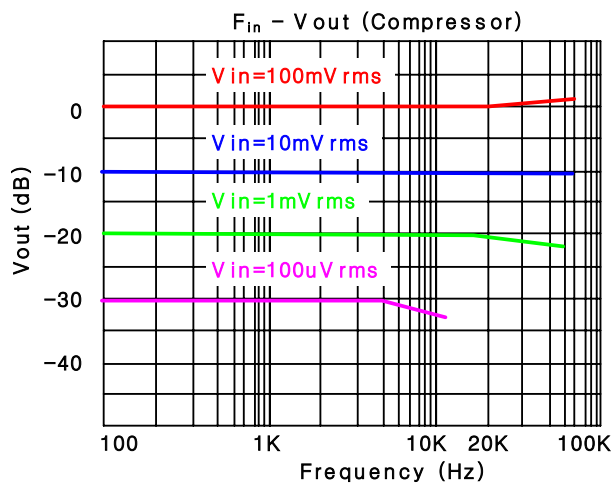
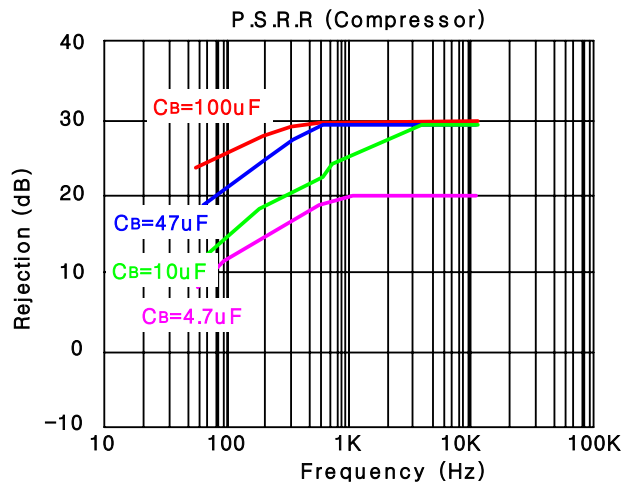
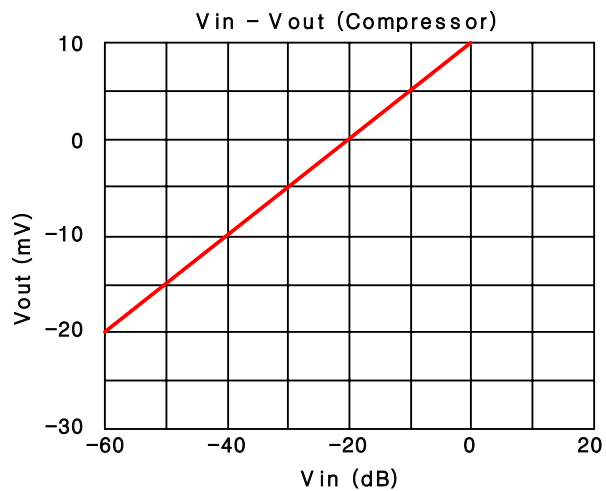

Typical Performance Characteristics(continued)

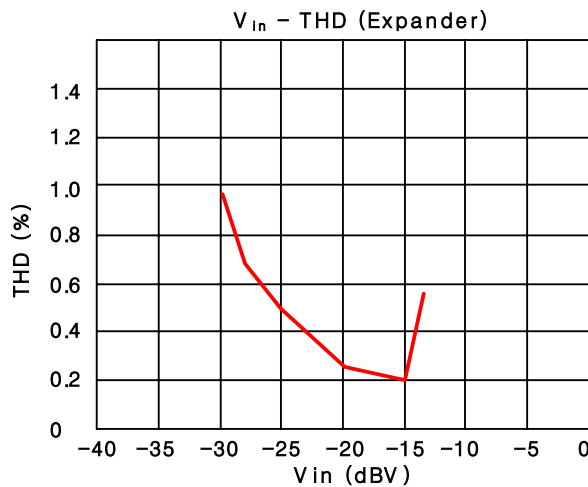
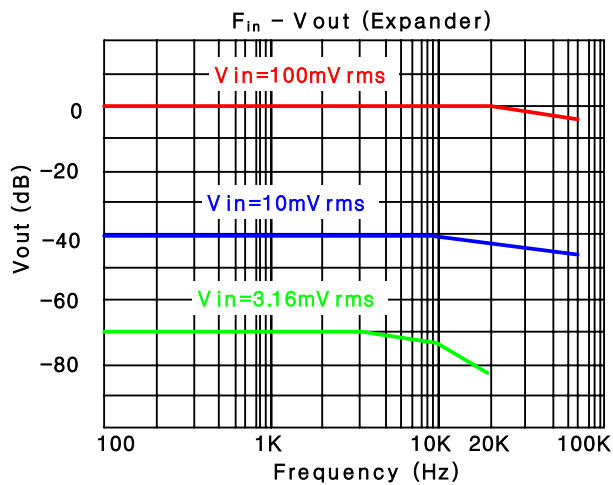
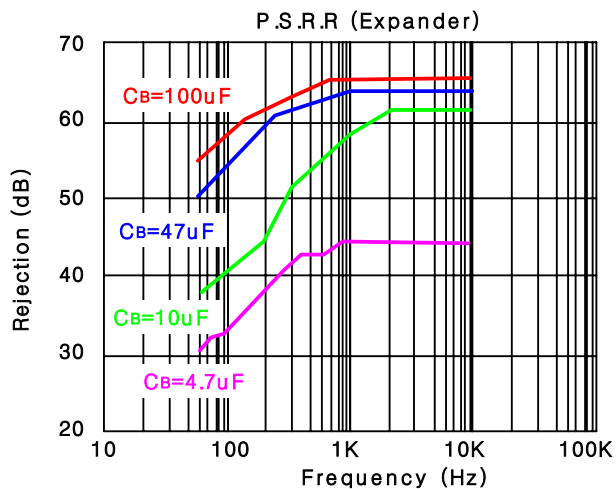
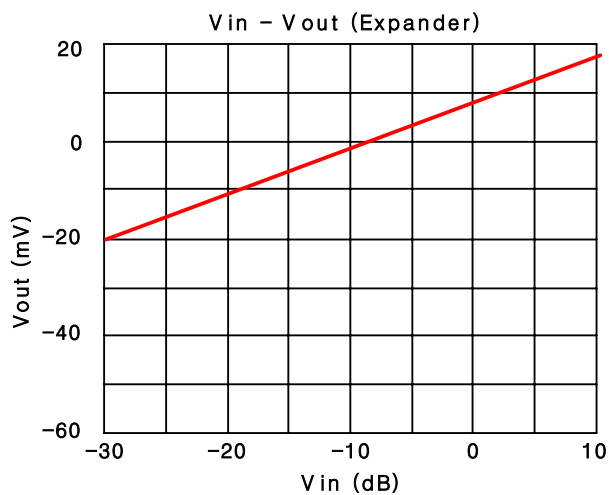

The AUK Corp. products are intended for the use as components in general electronic equipment (Office and communication equipment, measuring equipment, home appliance, etc.).

Please make sure that you consult with us before you use these AUK Corp. products in equipments which require high quality and / or reliability, and in equipments which could have major impact to the welfare of human life(atomic energy control, airplane, spaceship, transportation, combustion control, all types of safety device, etc.). AUK Corp. cannot accept liability to any damage which may occur in case these AUK Corp. products were used in the mentioned equipments without prior consultation with AUK Corp..

Specifications mentioned in this publication are subject to change without notice.