

## Description

The SL5021/P can fulfill the standards of other countries by changing the external component.

Dynamic or piezoelectric type can be used with receiver Each gain is controlled with AGC in accordance with the line current. The SL5021/P can be operated down to DC line 1.6V

## Features

- Independent adjustment of DC resistance and AC impedance.
- Voltage regulator with adjustable static resistance
- Symmetrical high-impedance inputs for dynamic magnetic or piezo-electric microphones
- Receiving amplifier for dynamic magnetic or piezo-electric earpieces
- DTMF signal interface
- Low DC line voltage : operated down to 1.6V
- Mute function
- DC line voltage adjustment facility

## Ordering Information

Type NO.	Marking	Package Code
SL5021	SL5021	SOP16
SL5021P	SL5021	DIP16

## Outline Dimensions

unit : mm

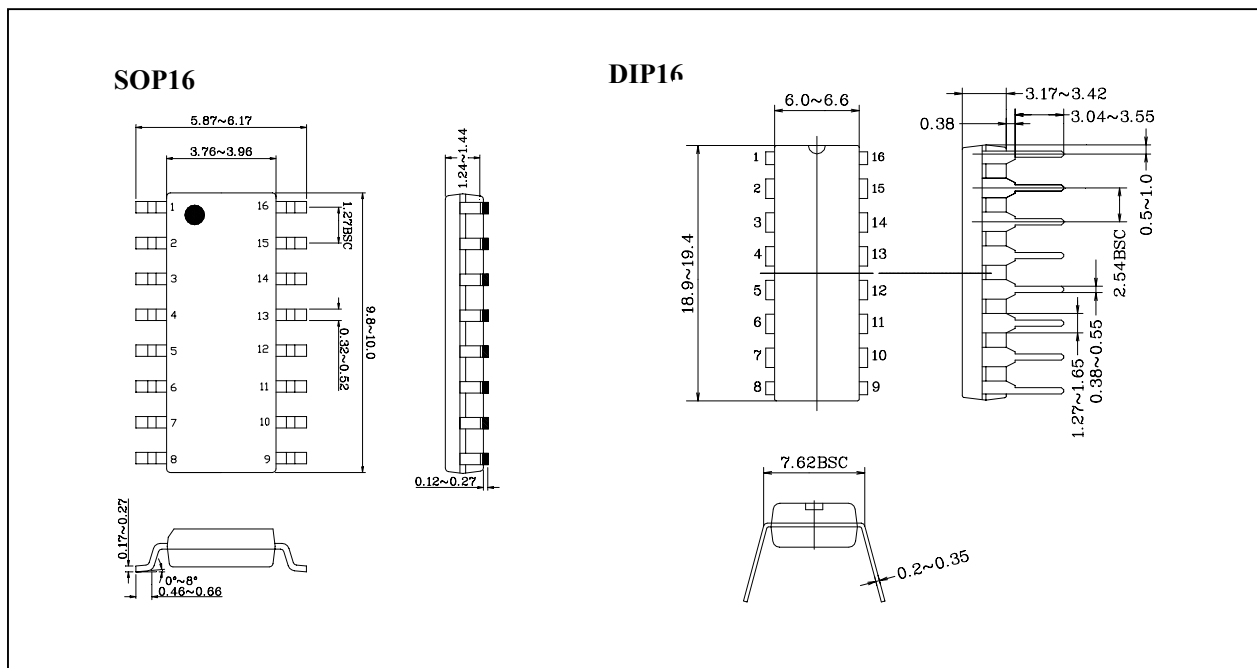

## Absolute Maximum Ratings

(Ta = 25°C)

Characteristic	Symbol	Rating	Unit
Line Voltage	$V_L$	12	V
Line Current	$I_L$	140	mA
Power Dissipation	$P_D$	666	mW
Operating Temperature	$T_{opr}$	-25 ~ +70	°C
Storage Temperature	$T_{stg}$	-40 ~ +125	°C

## Block Diagram

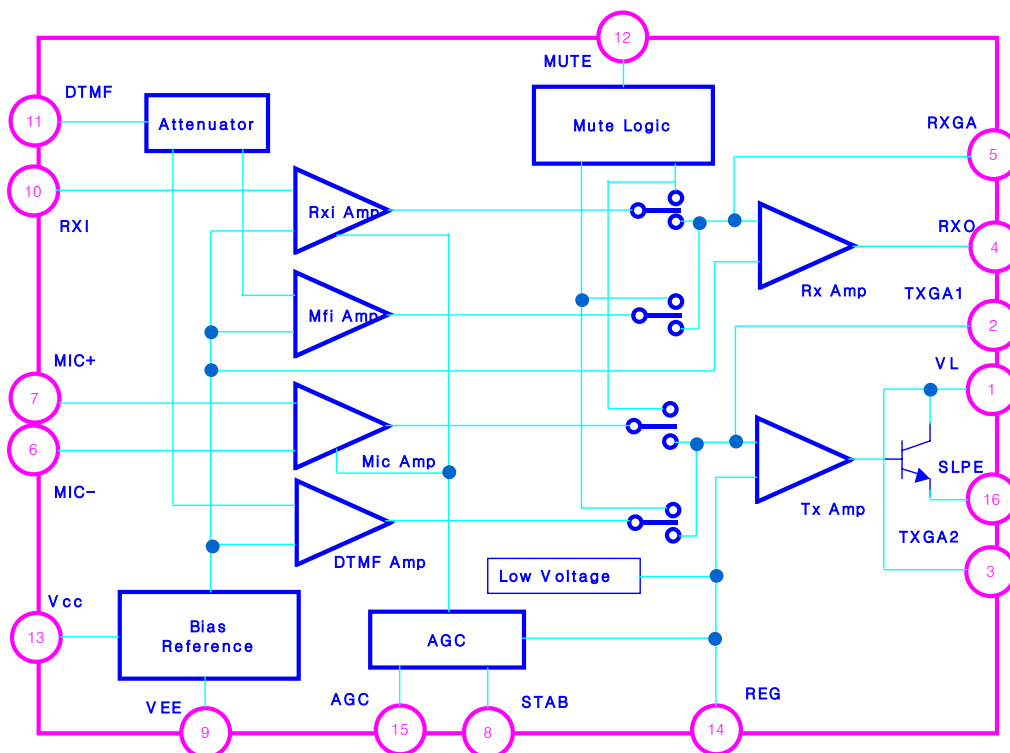

## PIN Description

Pin No.	Symbol	Description
1	$V_L$	Positive power line and TX Amp output
2	TXGA1	TX gain adjustment
3	TXGA2	TX gain adjustment
4	RXO	RX output
5	RXGA	RX gain adjustment
6	MIC <sup>-</sup>	Mic(-) input
7	MIC <sup>+</sup>	Mic(+) input

## PIN Description (continued)

Pin No.	Symbol	Description
8	SRAB	Current stabilizer
9	V <sub>EE</sub>	Ground
10	RXI	Rx input
11	DTMF	DTMF signal input
12	MUTE	'H' Mute input
13	V <sub>CC</sub>	Internal power supply pin
14	REG	Voltage regulator decoupling
15	AGC	Automation gain control input
16	SLPE	Slope(DC resistance) adjustment

## Electrical Characteristics

Characteristics	Symbol	Test Conditions	Min.	Typ.	Max.	Unit	
Line Voltage	V <sub>L</sub>	I <sub>Line</sub> = 1mA	-	1.6	-	V	
		I <sub>Line</sub> = 4mA	-	1.9	-		
		I <sub>Line</sub> = 15mA	3.55	4	4.25		
		I <sub>Line</sub> = 100mA	4.9	5.7	6.5		
		I <sub>Line</sub> = 140mA	-	-	7.5		
Variation with Temperature	$\Delta V_L / \Delta T$	I <sub>Line</sub> = 15mA	-	(-)0.3	-	mV/k	
Voltage drop over circuit between V <sub>L</sub> & V <sub>EE</sub> with external resistor R <sub>AV</sub>	R <sub>VA</sub>	I <sub>Line</sub> = 15mA R <sub>VA</sub> (R <sub>EG</sub> to S <sub>LPE</sub> ) = 39k	-	4.5	-	V	
		I <sub>Line</sub> = 15mA R <sub>VA</sub> (V <sub>L</sub> to R <sub>EG</sub> ) = 68k	-	3.5	-	V	
Supply Voltage	V <sub>CC</sub>	Mute=High	I <sub>p</sub> =1.2mA	2.2	2.7	-	V
			I <sub>p</sub> =0mA	-	3.4	-	
MIC input impedance	Z <sub>i</sub> (mic)	Between MIC- & MIC+	-	64	-	k $\Omega$	
		MIC- or MIC+ to V-	-	32	-		
Common mode Rejection Ratio	CMRR(T <sub>X</sub> )	-	-	82	-	dB	
TX Gain	G <sub>v</sub> (T <sub>X</sub> )	R7=68K, V <sub>in</sub> =3mV <sub>rms</sub>	50.5	52	53.5	dB	
TX Gain frequency Response	$\Delta G_{TXF}$	f=300 ~ 3400Hz	-	$\pm 0.2$	-	dB	
DTMF input impedance	Z <sub>I(MF)</sub>	-	-	20.7	-	k $\Omega$	

## Electrical Characteristics

Characteristics	Symbol	Test Conditions	Min.	Typ.	Max.	Unit	
DTMF Gain	$G_{V(MF)}$	R7=68k, DTMF mode	24	25.5	27	dB	
DTMF Gain Response	$\Delta G_{MF}$	R7=68k f=300~3400Hz	-	$\pm 0.2$	$\pm 5$	dB	
TX Gain Adjustment	$\Delta G_{vad(T_X)}$	R7 = 68k $\rightarrow$ 25k	(-)12	(-)8	(-)7	dB	
TX Dynamic output Voltage	$T_o(T_X)$	THD=10%	IL=4mA	-	0.8	-	Vrms
			IL=15mA	1.7	2.3	-	
TX noise output Voltage	$V_{no(T_X)}$	R7=68k Between pin6 & pin7=200 $\Omega$	-	(-)69	-	dBm	
RX input impedance	$Z_i(R_X)$	-	-	21	-	k $\Omega$	
RX output impedance	$Z_o(R_X)$	-	-	4	-	k $\Omega$	
RX Gain	$G_v(R_X)$	R4=100k, RL=300 $\Omega$	29.5	31	32.5	dB	
RX Gain Frequency Response	$\Delta G_{TXF}$	f=300 ~ 3400Hz	-	$\pm 0.2$	-	dB	
RX Dynamic output voltage	$V_o(R_X)$	THD=2% R4=100k	RL=150 $\Omega$	0.22	0.33	-	V
			RL=450 $\Omega$	0.3	0.48	-	
RX noise output voltage	$V_{no(R_X)}$	RL=300 $\Omega$ R4=100K IL= 15mA, Rxi=open	-	50	-	$\mu$ V	
RX Gain adjustment	$\Delta G_{v.adj}(R_X)$	R4=100k $\rightarrow$ 28K	(-)13	(-)11	(-)9	dB	
Mute input voltage	$V_{IH}(Mute)$	-	1.5	-	Vcc	V	
	$V_{IL}(Mute)$	-	-	-	0.3		
Mute input current	$I_{Mute}$	-	-	8	15	$\mu$ A	
Mute Attenuation	Matt(TX)	MIC+ or MIC- to V <sub>L</sub> (CCIT weighted)	-	70	-	dB	
DTMF Gain	$G_v(DTMF)$	voltage gain from DTMF to Rxo	-	70	-	dB	
TX Gain variation range By AGC	$\Delta G_{TXA}$	R6 = 110k IL=15mA ~ 70mA	-	(-)5.8	-	dB	
RX Gain variation range By AGC	$\Delta G_{RXA}$	R6=110k IL=15mA ~ 70mA	-	(-)5.5	-	dB	
Highest line current For maximum gain	$I_{HL(AGC)}$	R6=110k	17	23	26	mA	
Lowest line current For minimum gain	$I_{LL(AGC)}$	R6=110k	54	61	73	mA	



Typical Performance Characteristics

V<sub>LN</sub>, V<sub>CC</sub> V S LINE CURRENT

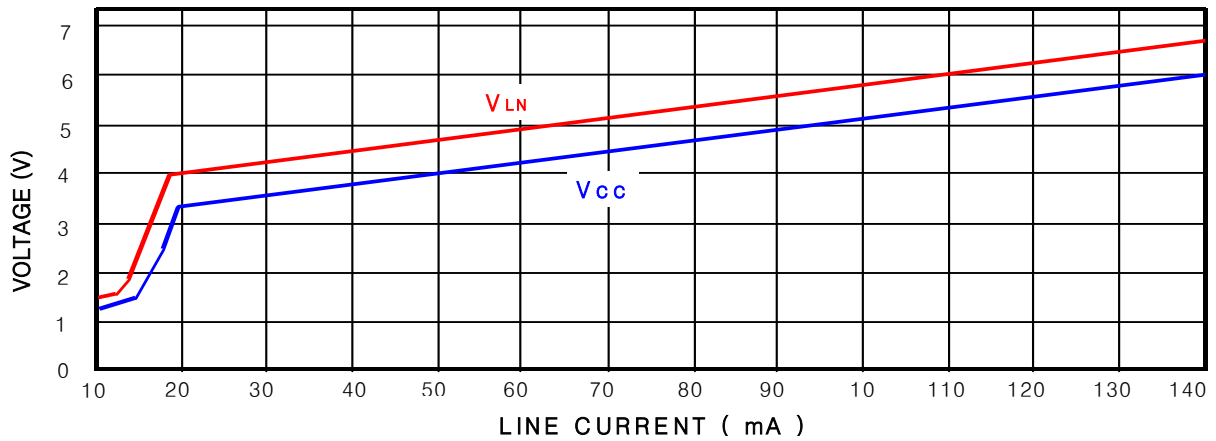

TRANSMIT GAIN V S LINE CURRENT

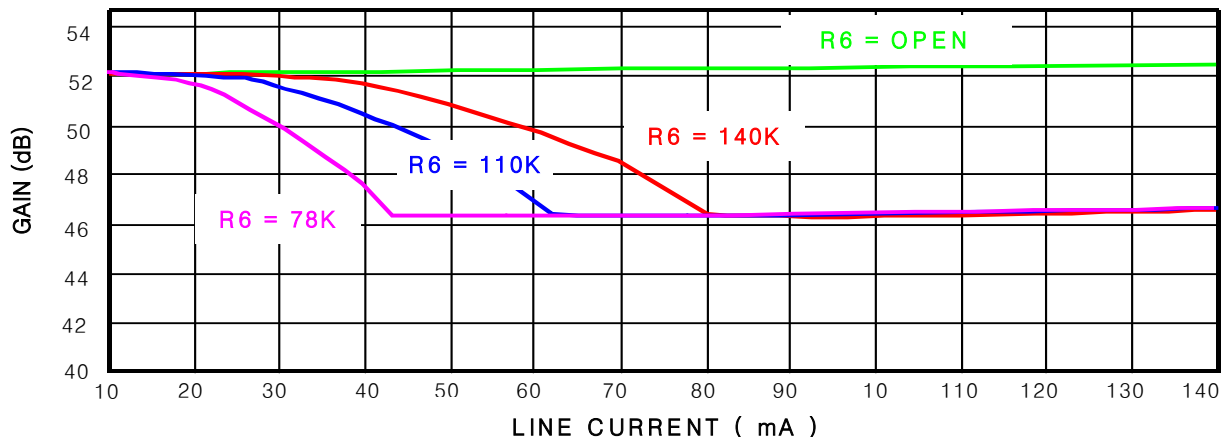

RECEIVE GAIN V S LINE CURRENT

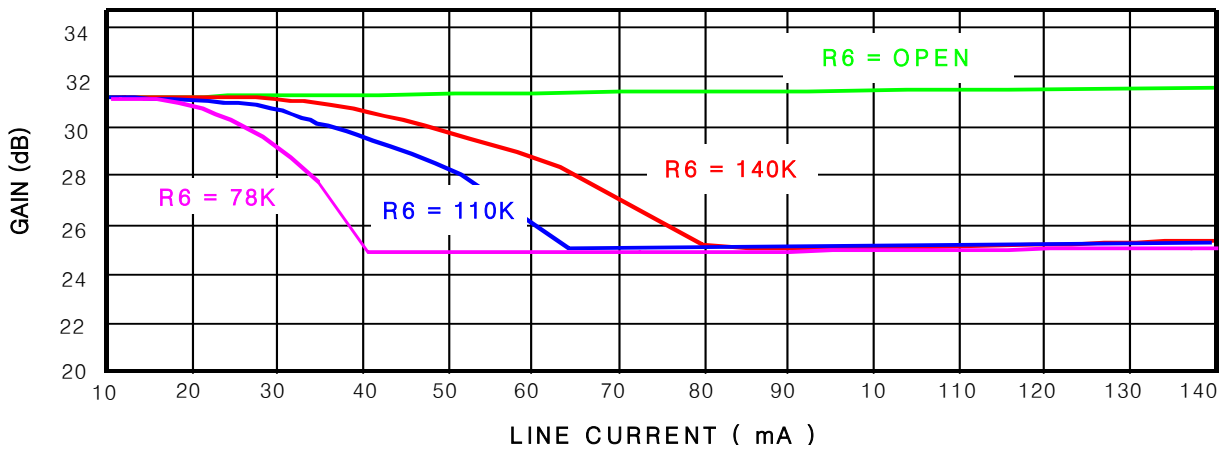

**These AUK products are intended for usage in general electronic equipments(Office and communication equipment, measuring equipment, domestic electrification, etc.).**

**Please make sure that you consult with us before you use these AUK products in equipments which require high quality and/or reliability, and in equipments which could have major impact to the welfare of human life(atomic energy control, airplane, spaceship, traffic signal, combustion central, all types of safety device, etc.).**

**AUK cannot accept liability to any damage which may occur in case these AUK products were used in the mentioned equipments without prior consultation with AUK.**