

1 2 3 4 5 6 7 8

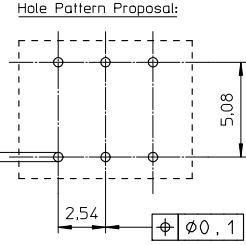

Coil former material: Sumikon PM9630 (PF), glass-reinforced.  
 UL file number: E41429 - UL94V-0.  
 Pin material: Copperclad steel, Sn plated.  
 Max. operating temp.: acc. to IEC 60 085 class H, 180°C.  
 Resistance to soldering heat: acc. to IEC 60 068-2-20 Part 2, Test Tb, method 1B, 350°C-3.5s.  
 Solderability: acc. to IEC 60 068-2-20 Part 2, Test Ta, method 1, 235°C-2s.  
 Min. winding area: 3.5 mm<sup>2</sup>  
 Mean length of turn: 18 mm.

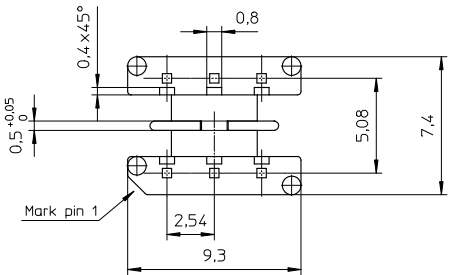
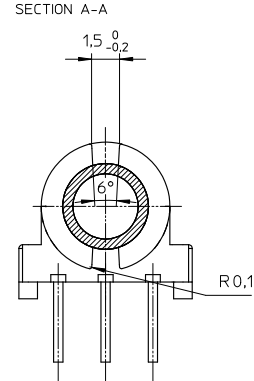
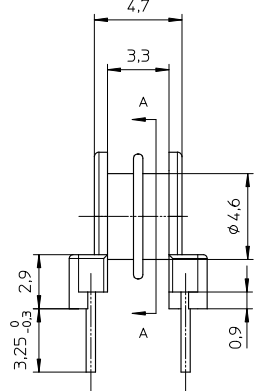
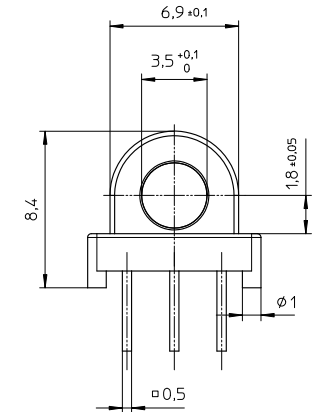

CLASSNO.		30-08-2006	
NAME		CSH-EP7-2S-6P-IZ	
PART NO.		4322 021 06571	
NAME	A. Wojtasz	SUPPL. NO.	1
CHECK	CONTR.	DATE	30-08-2006
PROPERTY	NO.	112 - 001	A3
© FERROXCUBE 2006			

1 2 3 4