

**1. Scope :**

This specification applies for the RM20 series of thick film chip resistors made by TA-I.

**2. Construction:**

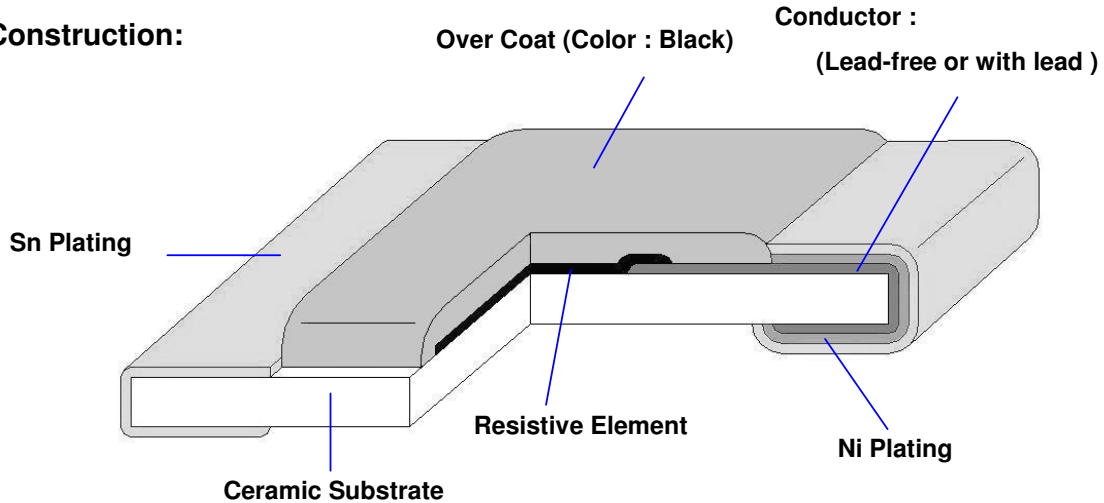

**3. Type Designation:**

**RM**

Product Code

**20**

Size

**J**

Tolerance

**EN**

Packaging

**103**

Nominal

RM : Chip Resistor

Power Rating

Resistance

20-2010(5025)	1/2W
---------------	------

J - $\pm 5\%$
G - $\pm 2\%$
F - $\pm 1\%$
D - $\pm 0.5\%$
B - $\pm 0.1\%$

E-Embossed Tape
+N: Lead-Free

3 digits, e.g.,:
(E-24) 103 = $10k\Omega$
0 = $0\Omega$
4 digits, e.g.,:
(E-96) 1540 = $154\Omega$
43R2 = $43.2\Omega$

4. Dimensions:

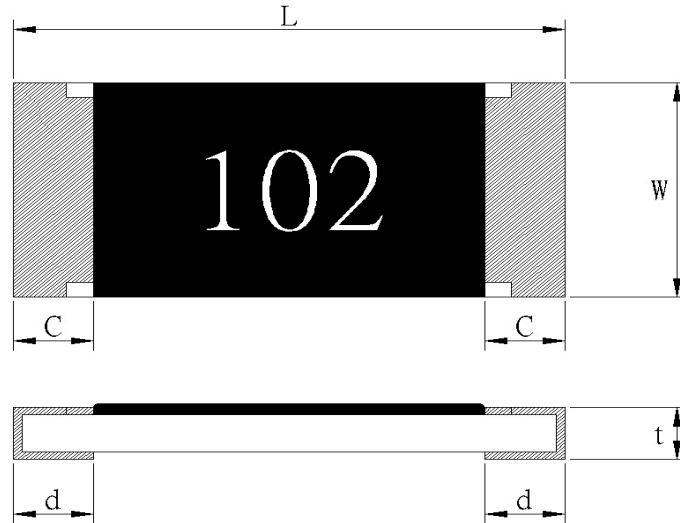

UNIT: mm

Type	L	W	C	d	t	Weight/pcs
RM20	5.00±0.15	2.50±0.15	0.60±0.30	0.50±0.25	0.60±0.10	23mg

5. Ratings & Characteristics :

Type	Power Rating at 70°C	Rated Voltage	Max. Working Voltage	Max. Over- Load Voltage	T.C.R (PPM/°C)	Resistance Range(Ω)				
						B(±0.1%) E-96	D(±0.5%) E-96	F(±1%) E-96	G(±2%) E-24	J(±5%) E-24
RM20	1/2W	Refer 5.2	200V	400V	±100	10Ω-560kΩ	10Ω-1MΩ	10Ω-1MΩ		
					±200			1M<R≤10MΩ	10Ω-10MΩ	10Ω-10MΩ
					±400			1Ω-9.1Ω	1Ω-9.1Ω	1Ω-9.1Ω 10M<R≤20MΩ
<b>0 Ω THICK FILM CHIP RESISTORS</b>										
Type	Rated Current		Max Overload Current		Resistance Range					
RM20	2A		5A		50mΩ MAX					
2. Operating Temp(°C): -55°C ~ +125°C										

**Note :** Except for the above standardized products, we also provide the customized products.

**5.1 Derating Curve :**

For resistors operated at ambient temperature over 70°C , power rating shall be derated in accordance with figure 1.

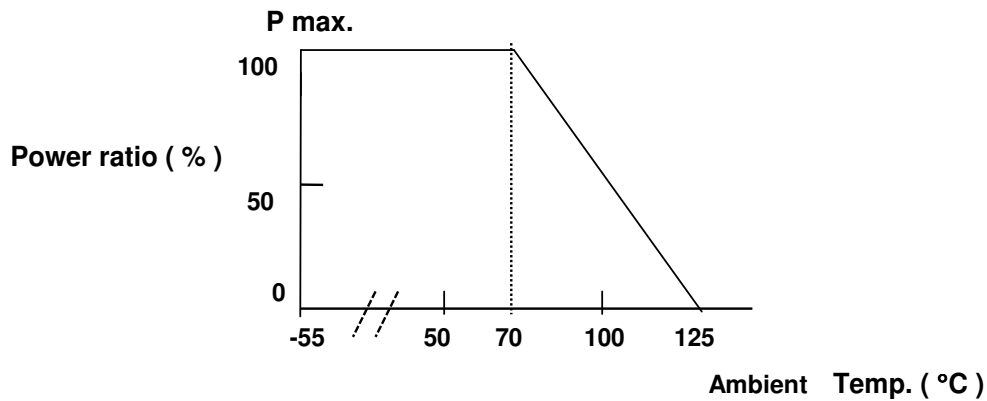

Figure 1

**5.2 Rated Voltage:**

The rated voltage is calculated by the following formula:

$$E = \sqrt{P * R}$$

$E$ =Rated Voltage(V)  
 $P$ =Rated Power(W)  
 $R$ =Resistance Value( $\Omega$ )

E.G. : What is RM20JTN102 the rated voltage ?

RM20JTN102 P:1/2W ; R:102 = 1K $\Omega$  = 1000 $\Omega$

$$E = \sqrt{0.5(W) * 1000(\Omega)} = 22.3 (V)$$

## 6. Reliability Tests: (As specified in JIS C 5202)

Test Items	Reference standard	Condition of Test	Test Limits
Temperature Coefficient of Resistance	JIS-C5202-5.2	-55~ +125 °C	Refer 5.0
Short Time Overload	JIS-C5202-5.5	2.5 X rated voltage for 5 sec	± (1% + 0.05 Ω ) 0 Ω : 50m Ω or less
Intermittent Overload	JIS-C5202-5.8	3.0 X rated voltage or Max Overloading voltage ,1sec "ON" , 25sec "OFF" , 10000 cycles	± (5.0% + 0.1 Ω ) 0 Ω : 50m Ω or less
Load Life	JIS-C5202-7.10	1000 hours at rated voltage , 70°C , 1.5hours "ON" , 0.5hour "OFF"	0.5%,1%:±(1.0%+0.05 Ω ) 2%,5%:±(3.0%+0.1 Ω ) 0 Ω : 100m Ω or less
Load Life with Humidity	JIS-C5202-7.9	1000 hours at rated voltage , 40±2°C , 90~95% RH 1.5hours "ON" , 0.5hour "OFF"	0.5%,1%:±(1.0%+0.05 Ω ) 2%, 5%:±(3.0%+0.1 Ω ) 0 Ω : 100m Ω or less Without mechanical damage
Rapid Change of Temperature	JIS-C5202-7.4	-55°C (30 min. ) / +155 °C (30 min. ) 5 cycles	0.5%,1% : ±(0.5%+0.05 Ω ) 2%, 5% : ±(1.0%+0.05 Ω ) 0 Ω : 50m Ω or less
Solderability	JIS-C5202-6.11	245±5°C solder, 2±0.5 sec dwell. Solder : Sn96.5 / Ag3.0 / Cu0.5	At least 95% of surface area of electrode shall be covered with new solder.
Robustness of Termination (Bending)	JIS-C5202—6.1	3mm deflection	0.5%,1%:±(0.5%+0.05 Ω ) 2%,5%:±(1.0%+0.05 Ω ) 0 Ω : 50m Ω or less
Dielectric Withstanding Voltage (Voltage Proof)	JIS-C5202-5.7	Applying voltage : 500V for a minute .	No abnormalities such as flashover, burning dielectric breakdown shall appear.
Insulation Resistance	JIS-C5202-5.6	Applying voltage 100V for 1 minute.	≥ 1G Ω
Resistance to Dry Heat	JIS-C5202-7.2	125±5°C for 96±4Hrs	0.5%,1% : ±(1.0%+0.05 Ω ) 2%,5% : ±(2.0%+0.1 Ω ) 0 Ω : 50m Ω or less
Resistance to Solder Heat	JIS-C5202-6.10	270 ±5°C solder , 10 ±1 sec dwell .	0.5%,1%:±(0.5%+0.05 Ω ) 2%, 5%:±(1.0%+0.05 Ω ) 0 Ω : 50m Ω or less

<b>TA-I</b>	<b>Thick Film Chip Resistors (Lead-Free for RM20 Series)</b>	No	TRM-200S008F
		page	5/10

Whisker	SONY SS-00254-8	<p>Component , Lead-Free Soldering part 8 : Solder Heat Resistance Test for SMD. Lead-Free Soldering "</p> <p>Temp. Cycles : -35 ± 5°C / 125 ± 5°C , Keep 7 min Testing duration : 500±4 hours</p> <p>Temp. Humidity Chambers: Temperature : 85°C Humidity : 85% RH Testing duration : 500±4 hours .</p>	Whisker formation : 50 um or less .
Resistance to Solder Heat	SONY SS-00254-5	<p>Component , Lead-Free Soldering part 5 : Solder Heat Resistance Test for SMD. Lead-Free Soldering "</p> <p>Flow Solder : Pre – heat : 100 to 105 °C 30±5 sec Temperature : 260±3°C 10 +1/- 0 sec The entire sample shall be dipped in solder. The specimen shall be stored at standard atmospheric conditions for 1 hour .</p> <p>Iron Solder : Bit temperature : 350 ±10°C Application time of soldering iron : 3 +1/- 0sec Apply the soldering iron to the electrode . The specimen shall be stored at standard atmospheric conditions for 1 hour , after which the measurements shall be made</p>	Electrical characteristics shall be Satisfied . Without distinct deformation in appearance

Note\* : RCWV : Rated continuous working voltage .

## 7. Marking :

### 7.1 ±2% & ±5%(E24)

Resistance value is expressed by 3 digits, the first two digits represent the significant figures of nominal resistance value in  $\Omega$ , and the third digit represents exponent for base of 10.

E.G. ; 472 =  $47 \times 10^2 = 4700 \Omega = 4.7K\Omega$

### 7.2 ±1% (E96)

Resistance value is expressed by 4 digits or 3 digits , the first three digits represent the significant figures of nominal resistance value in  $\Omega$ , and the fourth digit represents exponent for base of 10.

E.G. : 4701 =  $470 \times 10^1 = 4700 \Omega = 4.7K$

### 7.3 ±1%( E96/3digital )

The resistance value by 3 digits is requirement for customer.

8. Taping & Reel :

8.1 Taping Dimensions

8.1.1 4 mm pitch Emboss :

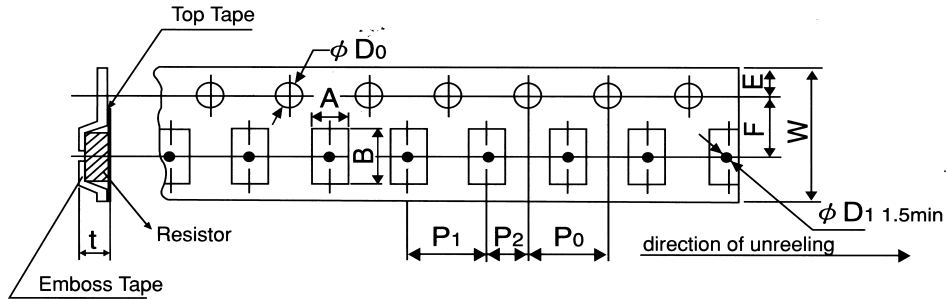

Packing Paper	Type	A	B	W	F	E	P <sub>1</sub>	P <sub>2</sub>	P <sub>0</sub>	D <sub>0</sub>	T
	RM20	2.8±0.2	5.3±0.2	12.0±0.2	5.5±0.05	1.75±0.1	4.0±0.1	2.0±0.05	4.0±0.05	φ 1.5 +0.1 -0	0.85±0.15

Type	Size	Package	Emboss Plastic Tape 4 mm pitch
RM	20		4000

8.2 Reel Specifications:

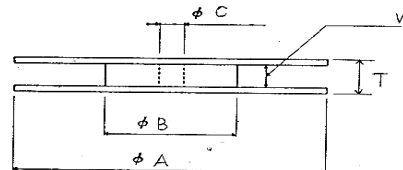
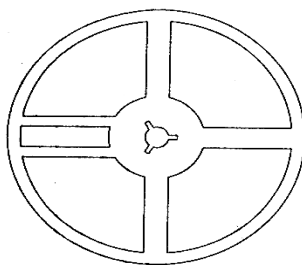

UNIT: mm

Type	φ A	φ B	φ C	W	T
RM20	178.0 ± 2.0	60.0 ± 1.0	13.0 ± 1.0	13.0 ± 1.0	15.5 ± 1.0

**8.3. Peel –off force :**

Peel –off force of paper and blister tape is in accordance with “JIS-C5202 ” that is , 0.1 to 0.7 N at a peel-off speed of 300 mm / minute.

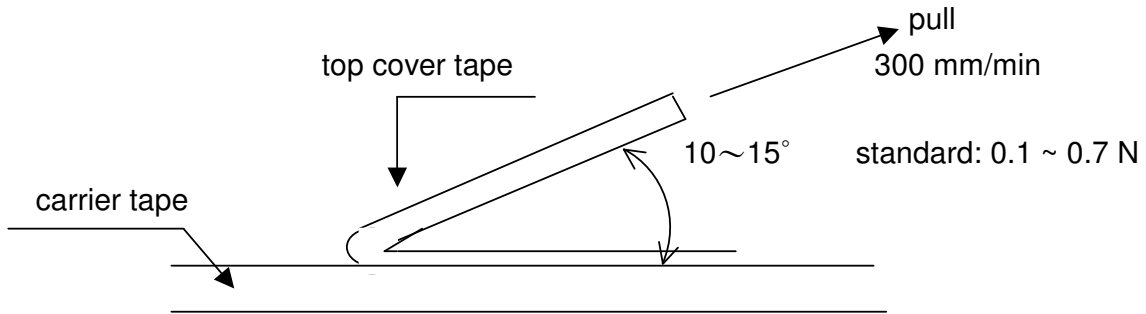

**9. Label :**

**9.1 Manufacture Label :**

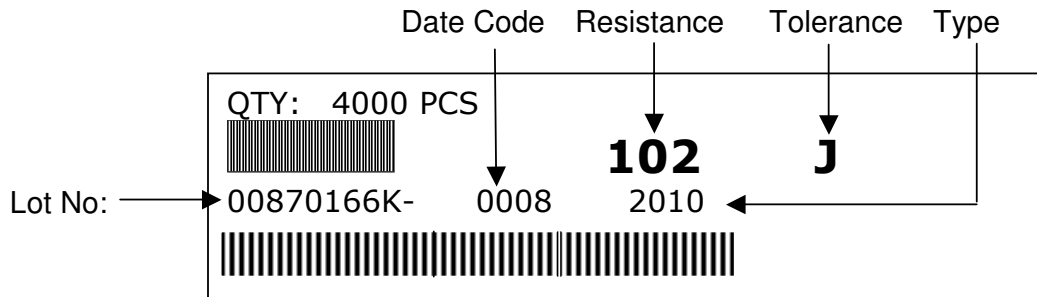

**9.2 Customer Label ( By customer request ):**

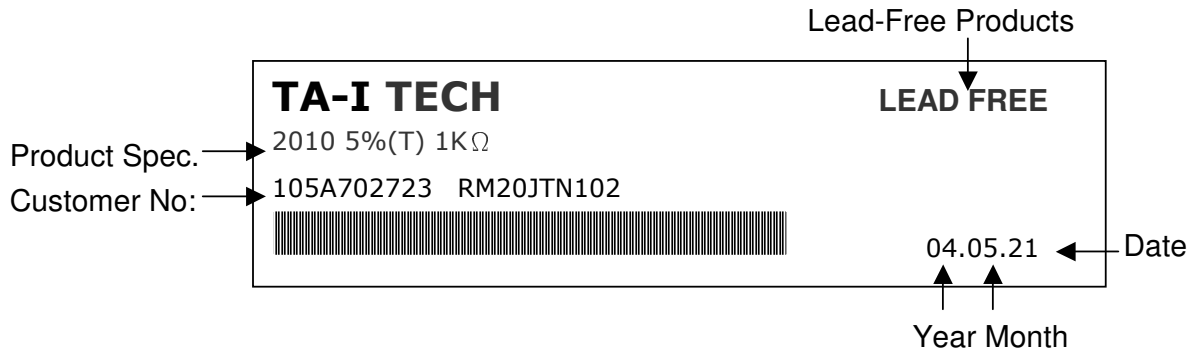

10. Recommended land patterns :

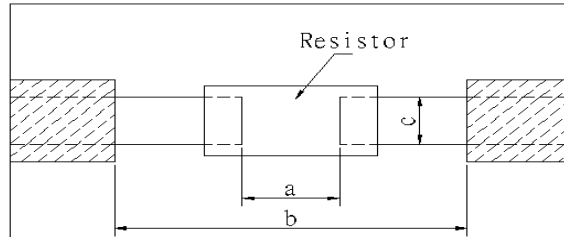

Land pattern		Dimension ( mm )		
Type	Size	a	b	c
RM	20 (2010 )	3.3~3.7	5.7~6.5	2.3~3.5

11. Recommend IR – Reflow profile : (solder : Sn96.5 / Ag3 / Cu0.5)

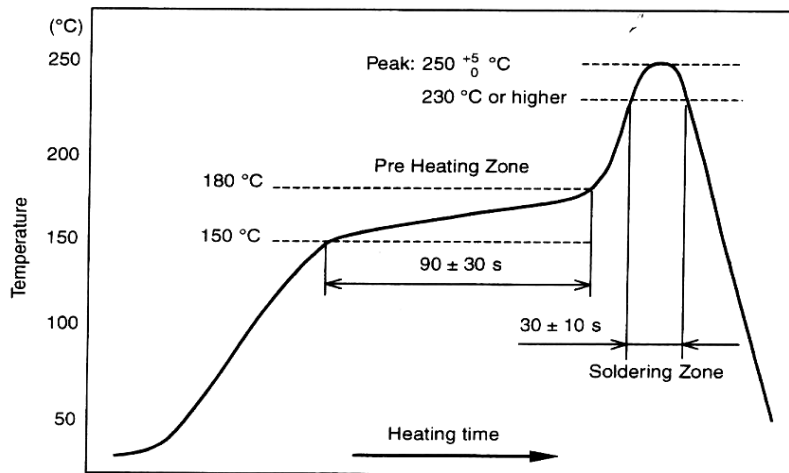

Peak :  $250 \begin{matrix} +5 \\ -0 \end{matrix} \text{ } ^\circ\text{C}$  , 5 sec

Pre – heat Zone : 150 to 180 °C , 90±30 sec

Soldering Zone : 230°C or higher , 30±10 sec



<b>TA-I</b>	<b>Thick Film Chip Resistors (Lead-Free for RM20 Series)</b>	<b>No</b>	TRM-200S008F
		<b>page</b>	9/10

**12. Storage Conditions:**

Temperature: 5°C~35°C, Humidity:40%~75%

**13. Shelf Life:**

2 years from manufacturing date.

**14. ECN :**

Engineering Change Notice: The customer will be informed with ECN if there is significant modification on the characteristics and materials described in Approval Sheet.

**15. Manufacturing Country & City :**

TA-I TECHNOLOGY CO., LTD. ( Taiwan– Tao Yuan )

Tel: 886-3-3246169 Fax : 886-3-3246167

**Associated companies :**

(1) FORTUNE TASK RESISTOR FACTORY ( China – Dongguan )

Tel : 86-769-8339-4790~3 Fax : 86-769-8339-4794

(2) TA-I TECHNOLOGY (DONGGUAN ) CO., LTD. ( China –Dongguan )

Tel : 86-769-8339-4790~3 Fax : 86-769-8339-4794

(3) TA-I TECHNOLOGY ( SU ZHOU ) CO., LTD. ( China – Su Zhou)

Tel :86- 512-63457879 Fax : 86-512-63457869

(4) TAI OHM ELECTRONICS ( M ) SDN. BHD. ( Malaysia – Pulaupinang )

Tel :604- 3900480 Fax : 604-3901481

(5) P.T.TAI ELECTRONICS Indonesia ( Indonesia – Jakarta )

Tel :002-62-21-44820254 Fax : 002-62-21-44820256

**TA-I TECHNOLOGY CO., LTD**

<b>TA-I</b>	<b>Thick Film Chip Resistors (Lead-Free for RM20 Series)</b>	<b>No</b>	TRM-200S008F
		<b>page</b>	10/10

**Revise record**

Date	Content	Owner
Nov.25.2005	4. Ratings & Characteristics : Adding Rating Voltage 5. Reliability Tests: Adding to Whisker & Resistance to soldering heat 7.3 Storage Conditions: Deleted to Storage Conditions 8.2 Customer Label Adding to Customer Label 10. Recommend IR – Reflow profile Adding to Recommend IR – Reflow profile 11. Storage Conditions: Adding to Storage Conditions: 12. Shelf Life Adding to Shelf Life :	Hank Liu
Jan.06.2006	4.Dimensions Adding weight/pcs	Henry Lu
Jul.10.2006	2. Conductor : Adding to (Lead-free or with lead) 3. Type Designation: 20-2010 changed 20-2010(5025) (E-24) 103 = $10^3\Omega$ = 10k $\Omega$ changed 103 = 10k $\Omega$ 5. Ratings & Characteristics : Resistance Range( $\Omega$ ) : B( $\pm 0.1\%$ ) E-96 (TCR $\pm 100$ ): 56 $\Omega$ -560k $\Omega$ changed 10 $\Omega$ -560K $\Omega$ D( $\pm 0.5\%$ )E-96(TCR $\pm 100$ ) : 56 $\Omega$ -560k $\Omega$ changed 10 $\Omega$ -1M $\Omega$ F( $\pm 1\%$ )E-96 (TCR $\pm 200$ ) : Adding To 1M<R $\leq$ 10M $\Omega$ J( $\pm 5\%$ )E-24 (TCR $\pm 400$ ) : : Adding To 10M<R $\leq$ 20M $\Omega$ 9.1 Manufacture label : Series number 3 codes changed to 4 codes 15. Manufacturing Country & City: Adding TA-I TECHNOLOGY (DONGGUAN ) CO., LTD	Vincent