



LA7975

PAL SIF Converter Circuit for TV and VCR Multi-system

Overview

The LA7975 is an IC that converts PAL SIF signals (5.5 MHz, 6 MHz, and 6.5 MHz) to 6 MHz. For the sake of high sound quality, this IC uses a unique mixer technique to suppress interference from NICAM signals.

Functions

- Mixer, amplifier, oscillator, oscillator mute

Features

- Resistant to interference by NICAM signals
- Small SIP-5 package
- Wide range of usage voltage (5 V to 12 V)

Package Dimensions

unit : mm

3042C-SIP5

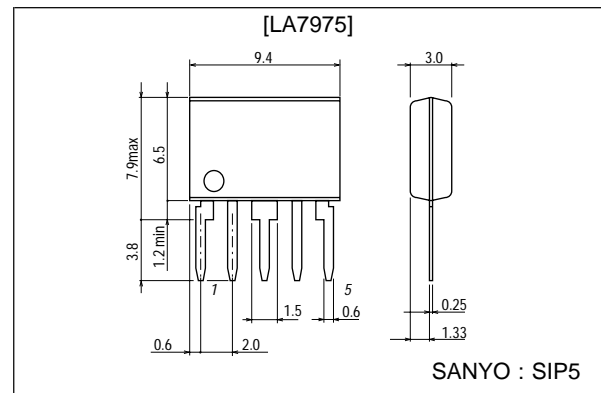

Specifications

Maximum Ratings at Ta = 25°C

Parameter	Symbol	Conditions	Ratings	Unit
Maximum supply voltage	V_{CC} max		13.2	V
Maximum feed current	I_5 max		3	mA
	I_4 max		1	mA
Allowable power dissipation	P_d max	$T_a \leq 70^\circ\text{C}$	200	mW
Operating temperature	T_{opr}		-20 to +70	°C
Storage temperature	T_{stg}		-40 to +150	°C

Operating Conditions at Ta = 25°C

Parameter	Symbol	Conditions	Ratings	Unit
Recommended supply voltage	V_{CC}		9	V
Operating voltage range	V_{CC} op		5 to 12	V

■ Any and all SANYO products described or contained herein do not have specifications that can handle applications that require extremely high levels of reliability, such as life-support systems, aircraft's control systems, or other applications whose failure can be reasonably expected to result in serious physical and/or material damage. Consult with your SANYO representative nearest you before using any SANYO products described or contained herein in such applications.

■ SANYO assumes no responsibility for equipment failures that result from using products at values that exceed, even momentarily, rated values (such as maximum ratings, operating condition ranges, or other parameters) listed in products specifications of any and all SANYO products described or contained herein.

SANYO Electric Co.,Ltd. Semiconductor Company

TOKYO OFFICE Tokyo Bldg., 1-10, 1 Chome, Ueno, Taito-ku, TOKYO, 110-8534 JAPAN

73096HA(II)/8282TS No.3994-1/6

LA7975

Operating Characteristics at $T_a = 25^\circ\text{C}$, $V_{CC} = 9\text{ V}$

Parameter	Symbol	Conditions	Test point	min	typ	max	Unit	
Current drain	I_{CC}		Pin 2	5	6.5	9	mA	
Conversion gain	5.5 MHz	G5.5	80 dB/ μV input	Pin 5	10	13.5	17	dB
	6.5 MHz	G6.5	80 dB/ μV input	Pin 5	10	13.5	17	dB
	6.0 MHz	G6.0	80 dB/ μV input, Pin 4 grounded with 10 k Ω	Pin 5	18.5	22	25.5	dB
Oscillation level	V_{OSC}		Pin 4	15	36	80	mVp-p	
Maximum output level	V_O max	5.5 MHz 100 dB/ μV input	Pin 5	109	112	115	dB/ μV	
Input impedance	R_i	5.5 MHz input			4.8		k Ω	
Pin voltages	V1		Pin 1	2.6	3	3.4	V	
	V4		Pin 4	7.6	8	8.4	V	
	V5		Pin 5	7.2	7.6	8	V	
500 kHz level difference relative to 6 MHz	OSC leak		Pin 5	30	44		dB	
Maximum input level	V_{IN} max			90			dB/ μV	
Oscillation stop current	I_4		Pin 4			300	μA	

Sample Application Circuit

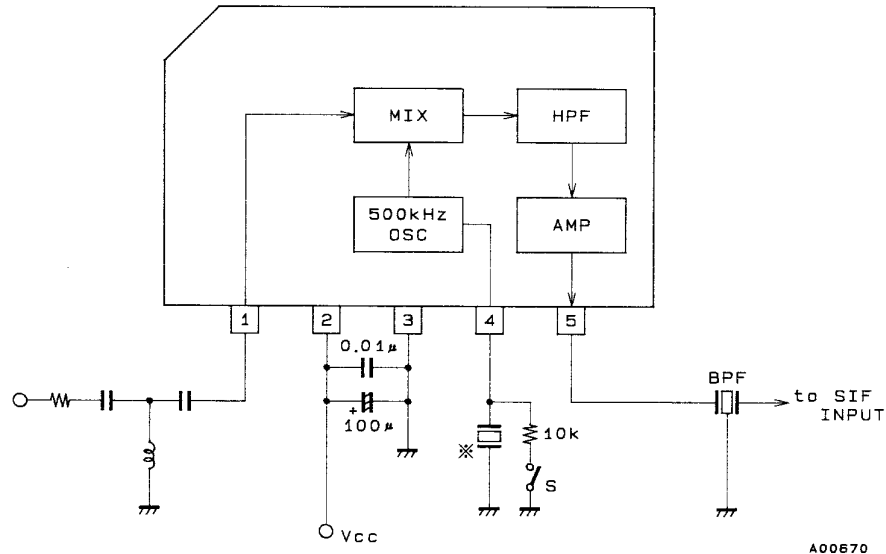

- ※ Oscillator
 500 kHz CSB503E5 Murata Industries, Ltd.
 1.5 MHz CSA1.500MK2 Murata Industries, Ltd.
 500 kHz EFOA500K04S Matsushita Electric, Ltd.

Unit (resistance: Ω , capacitance: F)

LA7975

Reference Example 1

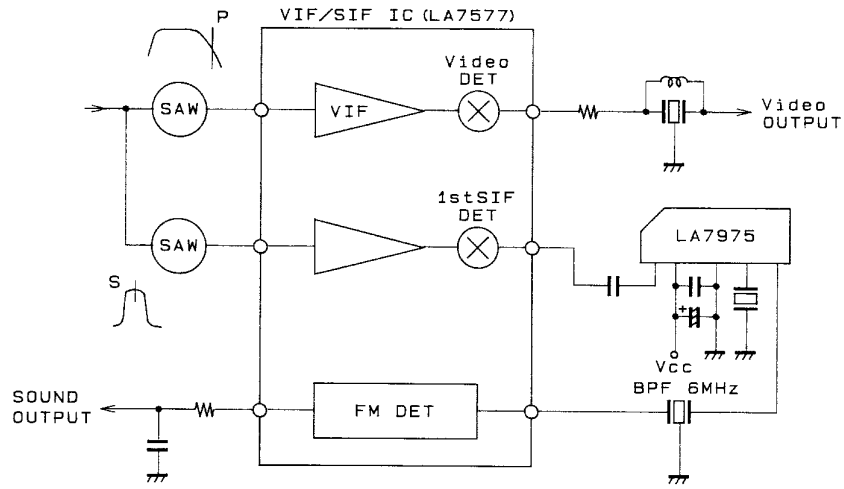

A00671

Reference Example 2

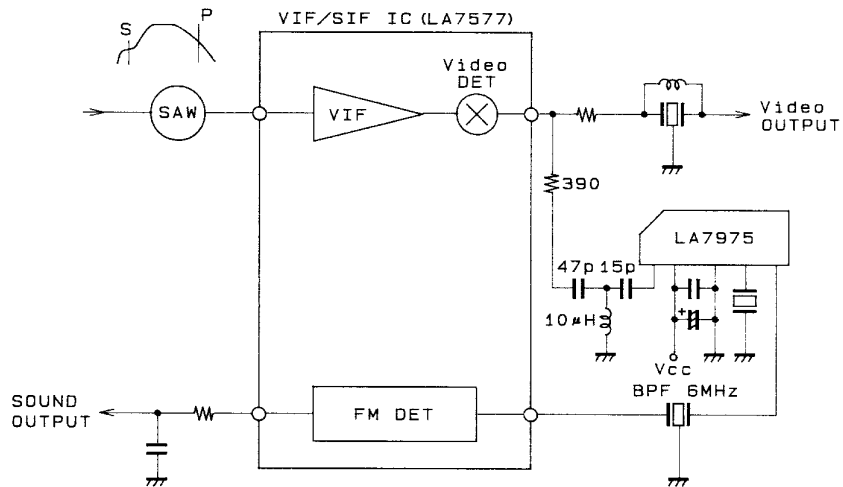

Unit (resistance: Ω , capacitance: F)

A00672

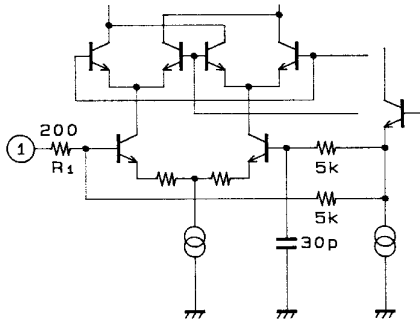

Figure 1 A00673

Unit (resistance: Ω, capacitance: F)

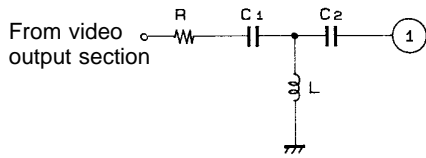

Figure 2

A00674

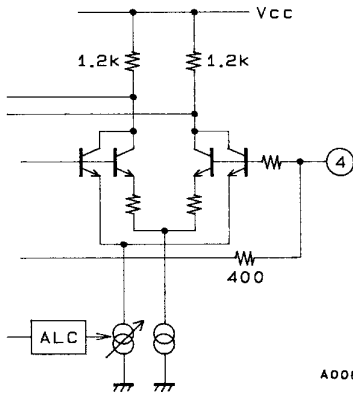

Figure 4 Unit (resistance: Ω)

A00676

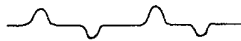

Figure 5

(Pin 4 oscillation waveform)

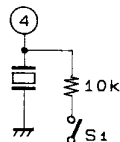

Figure 6

Unit (resistance: Ω)

A00677

- Pin 1 is the SIF input pin. The filter in Figure 2 can be connected to the input section to improve the buzz characteristic. Figure 3 shows the characteristics for the filter in Figure 2. If C1 is too small, the buzz characteristic improves for normal input, but the filter cuts into the sound carrier and the buzz characteristic deteriorates for the P/S (picture/sound carrier) ratio. Use $C1 \approx 20 \text{ pF}$ to 47 pF .

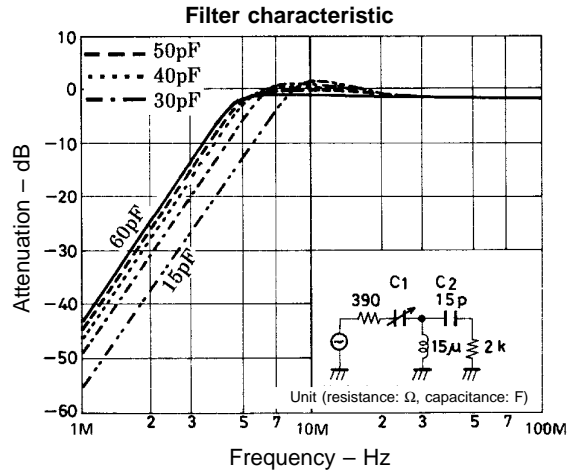

Figure 3

- Pin 4 is the ceramic oscillator pin. To make the oscillation waveform approach a sine wave, the oscillation level is controlled internally. Oscillation levels of 15 to 80 mVp-p at Pin 4 give the waveform shown in Figure 5. To stop oscillation, attach an external resistor as in Figure 6 and switch S1 on.

Here are the conditions for handling multiple systems.

Input frequency	Oscillator	Pin 5 output
5.5 MHz	500 kHz	6 MHz
6.0 MHz	Oscillation stop	6 MHz (pass through)
6.5 MHz	500 kHz	6 MHz
4.5 MHz	1.5 MHz	6 MHz

Figure 7

Figure 8 shows a proposed multi-system

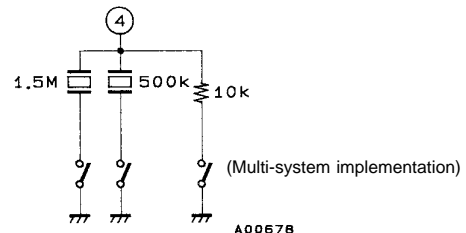

Figure 8 Unit (resistance: Ω)

A00678

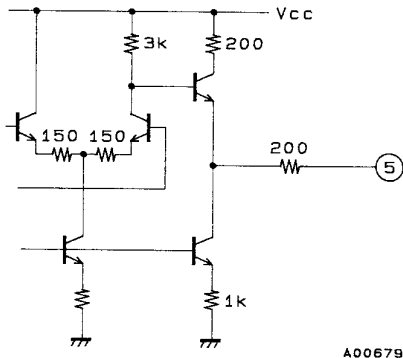

Figure 9 Unit (resistance: Ω)

• Pin 5 is the output pin. The output from Pin 5 is input to the SIF via a 6 MHz bandpass filter (BPF).
 When 5.5 MHz is input to Pin 1, the spectrum shown in Figure 10 is obtained at Pin 5. Even if there is a 5.85 MHz NICAM signal, the D/U (desirable/undesirable) ratio at Pin 5 increases and the buzz characteristic does not deteriorate.

When 6 MHz is input at Pin 1 and there is a 6.552 MHz NICAM signal, then 6.552 MHz is mixed with 500 kHz to make 6.052 MHz. This becomes an interference signal and is within the band for 6 MHz. Therefore, for 6 MHz input, Pin 4 is grounded with 10 kΩ to stop the oscillation and pass through the input signal 6 MHz as is.

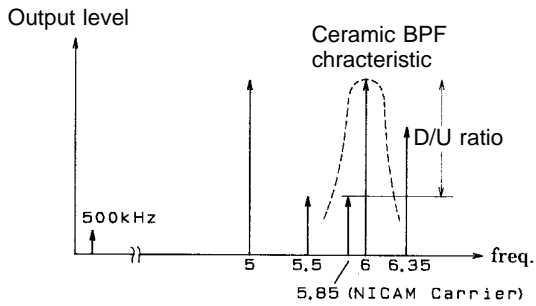

Figure 10 (5.5 MHz input)

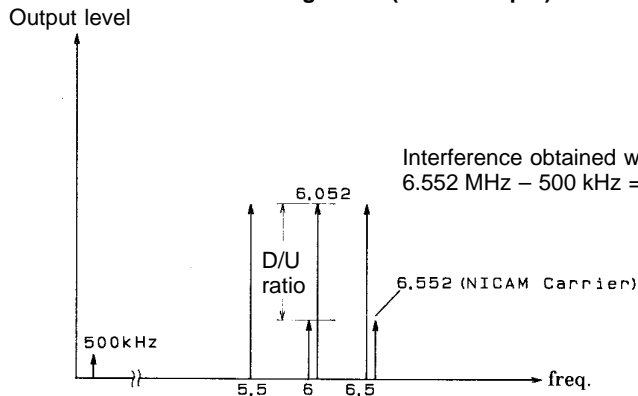
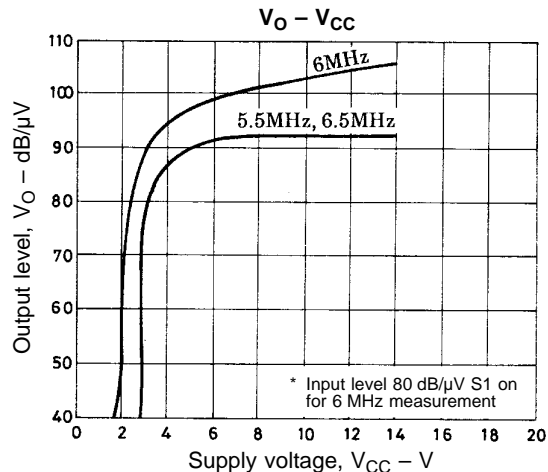
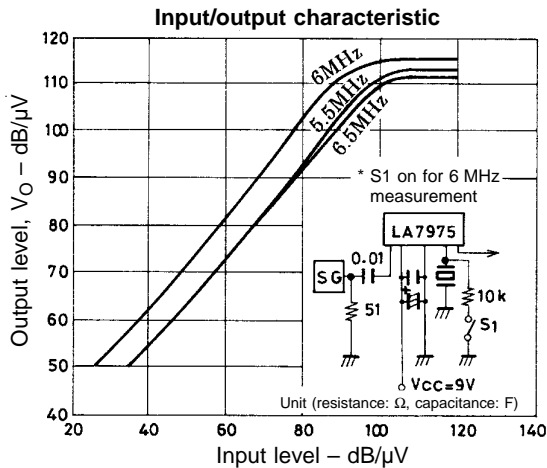
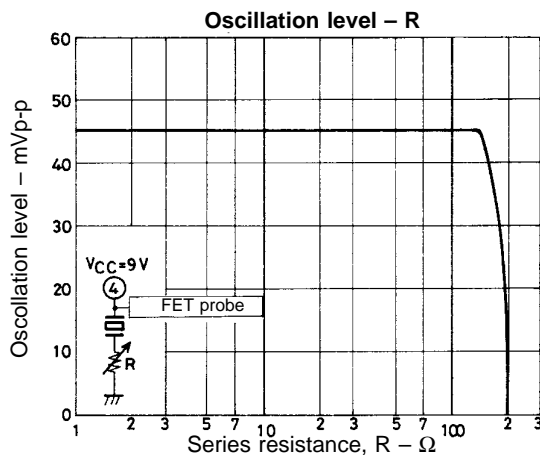
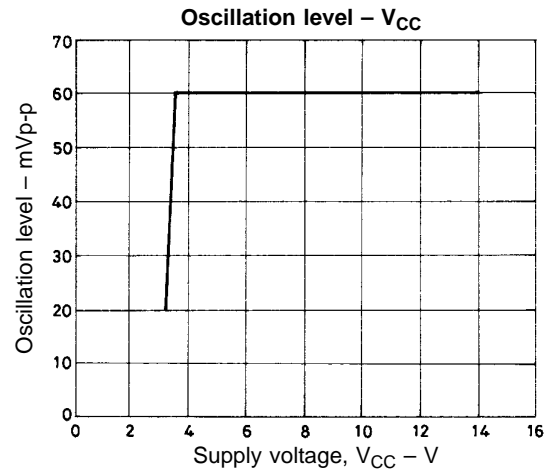
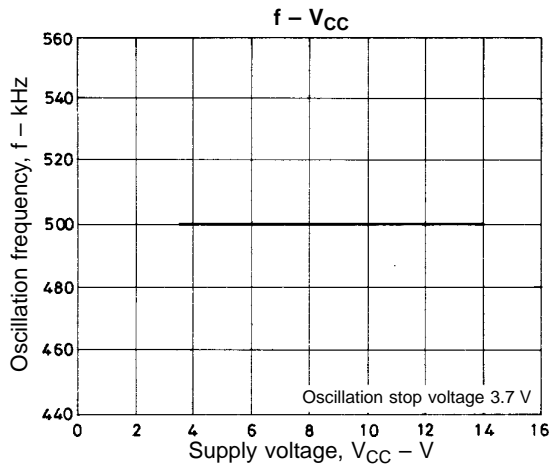

Figure 11 (6 MHz input)

Reference Characteristic Diagram





- Specifications of any and all SANYO products described or contained herein stipulate the performance, characteristics, and functions of the described products in the independent state, and are not guarantees of the performance, characteristics, and functions of the described products as mounted in the customer's products or equipment. To verify symptoms and states that cannot be evaluated in an independent device, the customer should always evaluate and test devices mounted in the customer's products or equipment.
- SANYO Electric Co., Ltd. strives to supply high-quality high-reliability products. However, any and all semiconductor products fail with some probability. It is possible that these probabilistic failures could give rise to accidents or events that could endanger human lives, that could give rise to smoke or fire, or that could cause damage to other property. When designing equipment, adopt safety measures so that these kinds of accidents or events cannot occur. Such measures include but are not limited to protective circuits and error prevention circuits for safe design, redundant design, and structural design.
- In the event that any or all SANYO products (including technical data, services) described or contained herein are controlled under any of applicable local export control laws and regulations, such products must not be exported without obtaining the export license from the authorities concerned in accordance with the above law.
- No part of this publication may be reproduced or transmitted in any form or by any means, electronic or mechanical, including photocopying and recording, or any information storage or retrieval system, or otherwise, without the prior written permission of SANYO Electric Co., Ltd.
- Any and all information described or contained herein are subject to change without notice due to product/technology improvement, etc. When designing equipment, refer to the "Delivery Specification" for the SANYO product that you intend to use.
- Information (including circuit diagrams and circuit parameters) herein is for example only; it is not guaranteed for volume production. SANYO believes information herein is accurate and reliable, but no guarantees are made or implied regarding its use or any infringements of intellectual property rights or other rights of third parties.

This catalog provides information as of July, 1996. Specifications and information herein are subject to change without notice.