



# LA2110 — Monolithic Linear IC FM Noise Canceller

## Overview

The LA2110 has the capability to effectively remove external noise (pulse noise) caused by engine, etc. and is used in conjunction with a PLL FM multiplex stereo demodulator (such as LA3375) with pilot signal canceller.

## Features

- Pilot signal compensation function.
- By using in conjunction with PLL FM multiplex stereo demodulator with pilot signal canceller, adverse effect caused by pilot signal can be compensated.
- Low distortion factor : THD = 0.02%, 300mV.
- Good space facator due to single end package.
- Variable input type noise AGC system. This system widens the noise detector's dynamic range, so that pulse noise can be satisfactorily detected even in a weak electric field, and pulse noise is removed without adversely affecting distortion factor.

## Specifications

### Absolute Maximum Ratings at Ta = 25°C

Parameter	Symbol	Conditions	Ratings	Unit
Maximum supply voltage	V <sub>CC</sub> max		16	V
Allowable power dissipation	Pd max	Ta ≤ 50°C	450	mW
Operating temperature	Topr		-20 to +75	°C
Storage temperature	Tstg		-40 to +125	°C

### Recommended Operating Conditions at Ta = 25°C

Parameter	Symbol	Conditions	Ratings	Unit
Recommended supply voltage	V <sub>CC</sub>		12	V
Operating voltage range	V <sub>CC</sub> op		8 to 15	V

■ Any and all SANYO Semiconductor Co.,Ltd. products described or contained herein are, with regard to "standard application", intended for the use as general electronics equipment (home appliances, AV equipment, communication device, office equipment, industrial equipment etc.). The products mentioned herein shall not be intended for use for any "special application" (medical equipment whose purpose is to sustain life, aerospace instrument, nuclear control device, burning appliances, transportation machine, traffic signal system, safety equipment etc.) that shall require extremely high level of reliability and can directly threaten human lives in case of failure or malfunction of the product or may cause harm to human bodies, nor shall they grant any guarantee thereof. If you should intend to use our products for applications outside the standard applications of our customer who is considering such use and/or outside the scope of our intended standard applications, please consult with us prior to the intended use. If there is no consultation or inquiry before the intended use, our customer shall be solely responsible for the use.

■ Specifications of any and all SANYO Semiconductor Co.,Ltd. products described or contained herein stipulate the performance, characteristics, and functions of the described products in the independent state, and are not guarantees of the performance, characteristics, and functions of the described products as mounted in the customer's products or equipment. To verify symptoms and states that cannot be evaluated in an independent device, the customer should always evaluate and test devices mounted in the customer's products or equipment.

# LA2110

**Electrical Characteristics** at  $T_a = 25^\circ\text{C}$ ,  $V_{CC} = 12\text{V}$ , See specified Tset Circuit

Parameter	Symbol	Conditions		Ratings			Unit
		(input pin)	(output pin)	min	typ	max	
Quiescent current	$I_{CCO}$				16	25	mA
Voltage gain	VG	V7 = 300mV, f = 1kHz	Output	-0.2	0.8	1.8	dB
Input signal dynamic range	$V_D$	V7, f = 1kHz	Output, THD = 1%	1.3			V
Input impedance	$Z_{IN}$	V7 = 300mV, f = 1kHz		36k	51k	67k	$\Omega$
Total harmonic distortion	THD	V7 = 300mV, f = 1kHz	Output		0.01	0.03	%
Low-pass amp gain	$V_{GL}$	V5 = 300mV, f = 1kHz	V4	1.0	1.1	1.2	times
High-pass amp gain	$V_{GH}$	V9 = 100mV, f = 200kHz	V10	1.2	1.4	1.65	times
Inverting amp distortion factor	THD <sub>I</sub>	V15 = 100mV, f = 19kHz	Output			0.1	%
Inverting amp distortion Range	$V_{DI}$	V15, f = 19kHz	Output, THD = 1%	300			mV
Inverting amp gain	$V_{GI}$	V15 = 100mV, f = 19kHz	Output	1.0	1.3	1.6	times
Output noise voltage	$V_{NO}$	V7, V15 shorted to GND	Output, 100kHz low-pass filter		30	60	$\mu\text{V}$
Gate time	$t_{\text{gate}}$	V7 = 100mVp-p, 1 $\mu\text{s}$ , f = 1kHz	Output	13	21	30	$\mu\text{s}$
Noise sensitivity	SN	V7, 1 $\mu\text{s}$ , f = 1kHz	Output			30	mVp-o

## Package Dimensions

unit : mm (typ)

3193A

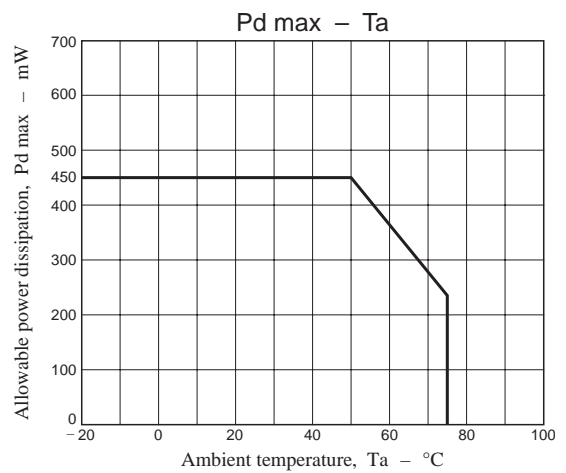
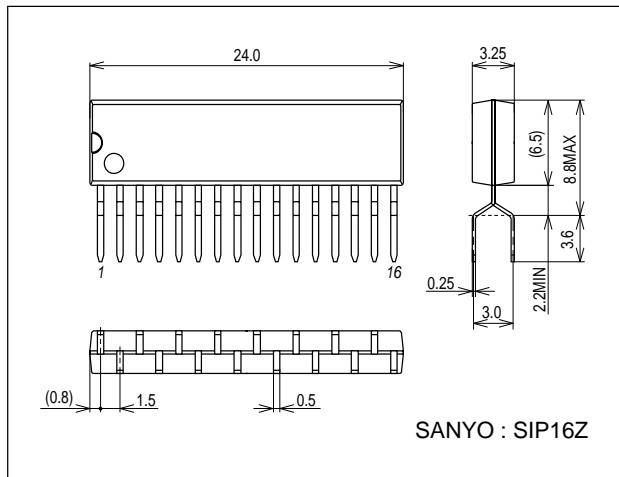

# LA2110

## Test Circuit

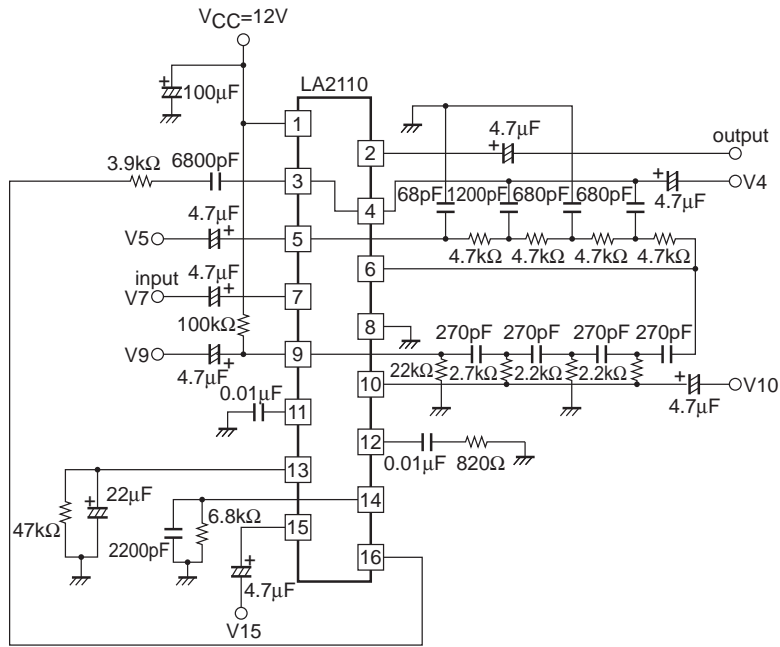

## Block Diagram

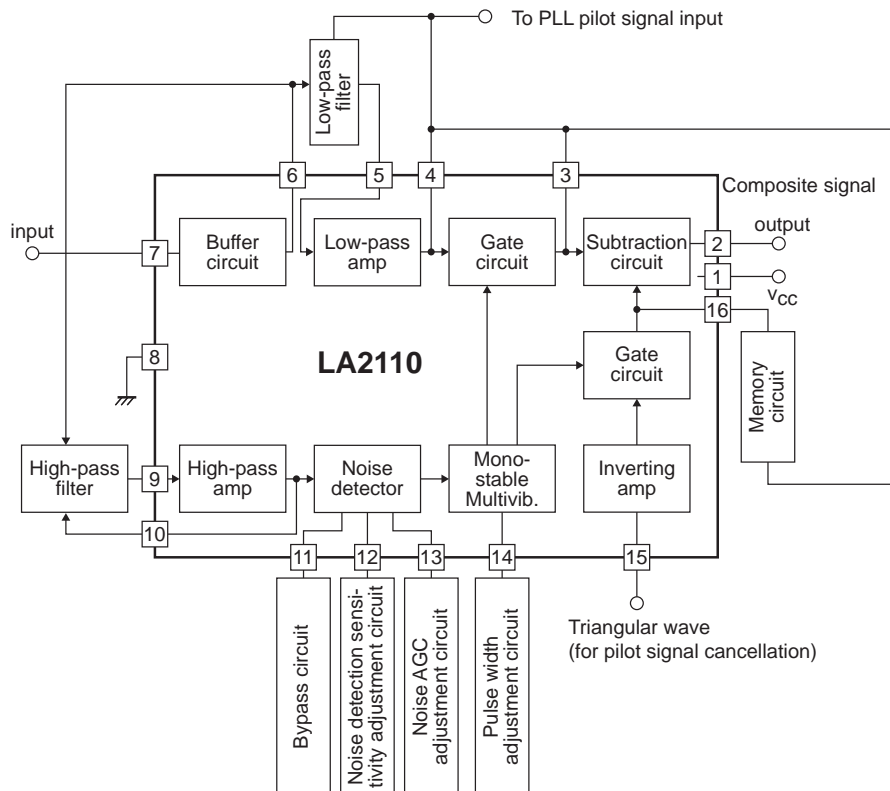

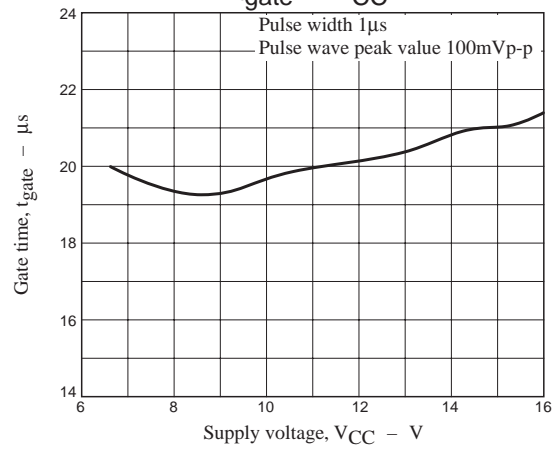
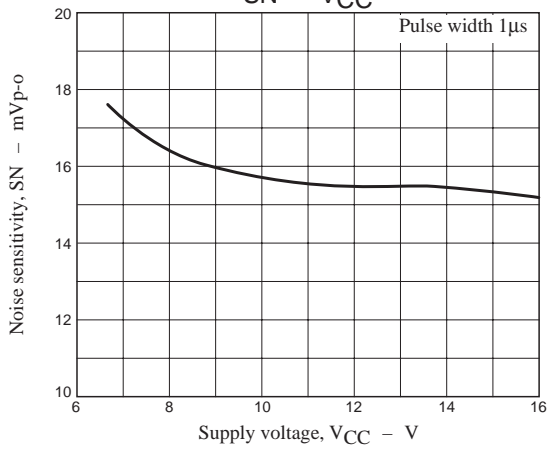
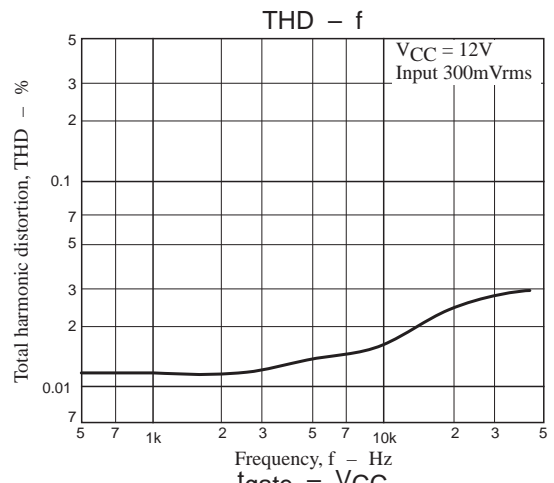
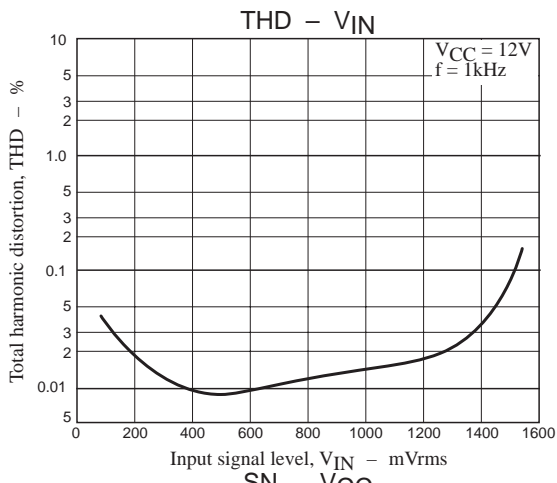

Theory of LA2110 Noise Canceller

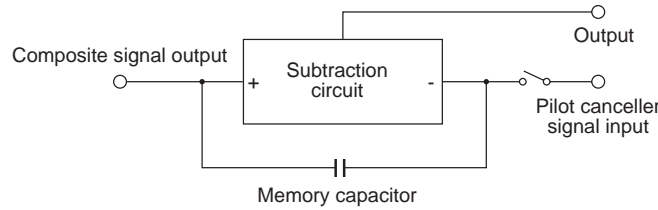

In order to simplify the operation theory, the composite signal component is given only as a low frequency signal and a pilot cancel signal has the same phase, same amplitude as the pilot signal in the composite signal.

Since the output voltage is the differential voltage of the plus and minus input of the subtraction circuit, it is equal to the voltage between the memory capacitor terminals. When the gate is closed, the composite signal is applied to the plus input terminal of the subtraction circuit, and the pilot cancel signal is applied to the minus input terminal. Thus the pilot signal is cancelled from the output and only the low frequency signal appears. In the same way, the voltage between the memory capacitor terminals is the differential voltage of the composite signal and the pilot cancel signal, so only the low frequency signal appears.

When pulse noise is generated and the gate opens, the plus input and minus input signal waveforms of the subtraction circuit become equal. This is because the input impedance of the subtraction circuit is extremely high, so the memory capacitor is considered AC-shorted. Thus, when pulse noise is generated in the composite signal, the same pulse noise appears in minus as well as plus input of the subtraction circuit. As a result, pulse noise does not appear in the output. The voltage in the output has a DC level difference of plus and minus input, and that is the voltage held by the memory capacitor. This voltage is that between the memory capacitor terminals just before the gate opens, so it is the low frequency signal voltage just before the gate opens. Because the subtraction circuit input impedance is high, no charge/discharge current flows in the memory capacitor while the gate is open, so the memory capacitor can hold the voltage between its terminals.

The voltage waveforms are illustrated below.

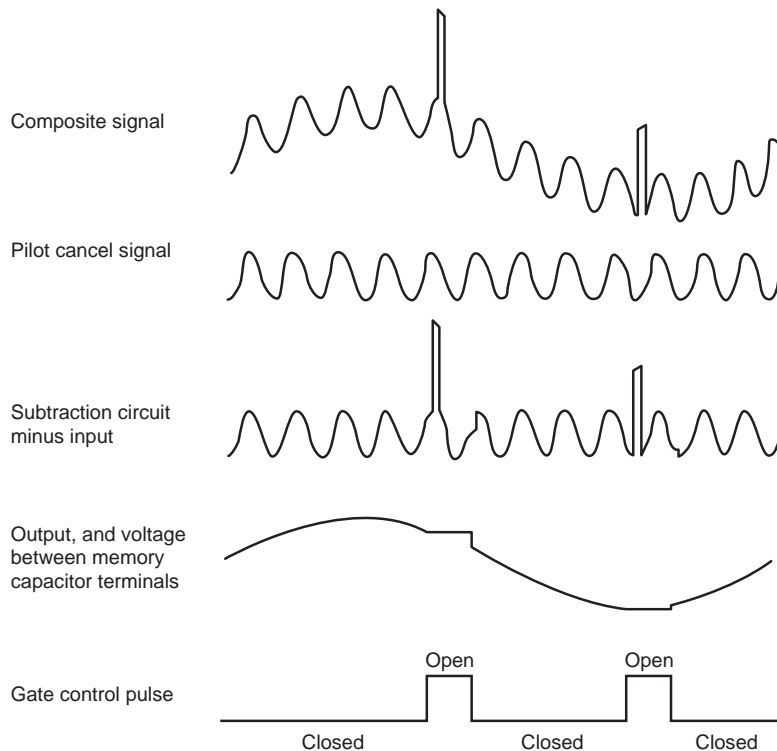

Note : The pilot cancel signal is given as sinusoidal in this explanation, but in the actual application circuit, pilot cancel is performed by a triangular wave.

Sample Application Circuit : LA2110 & LA3375

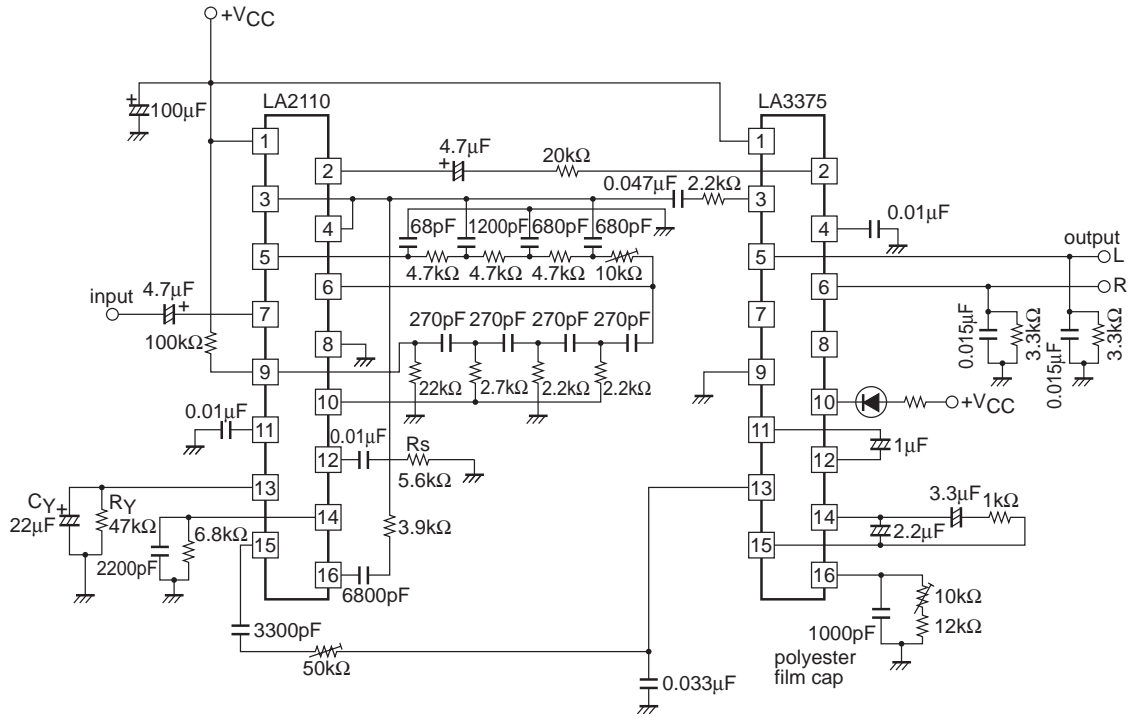

Note : When using the sample application circuit :

1. Separation adjustment is performed with 10kΩ variable resistance in low-pass filter.
2. Change noise detection sensitivity control  $R_s$  to an adequate value for strong or medium electric field.
3. Adjust noise AGC with  $C_Y$ ,  $R_Y$  for effective noise suppression in a medium or weak electric field.
4. Adjust pilot cancel degree with variable resistance of 50kΩ connected to LA2110 pin 15.
5. By changing the 1µF capacitor between LA3375 pin 11 and 12, pilot cancel follow-up response time can be changed. But if the value is decreased, distortion factor, etc. will be adversely affected.

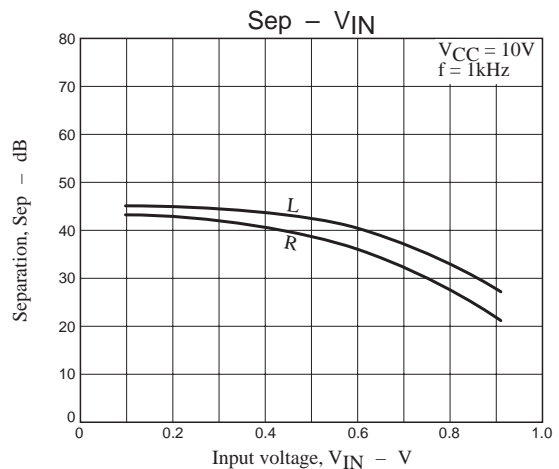
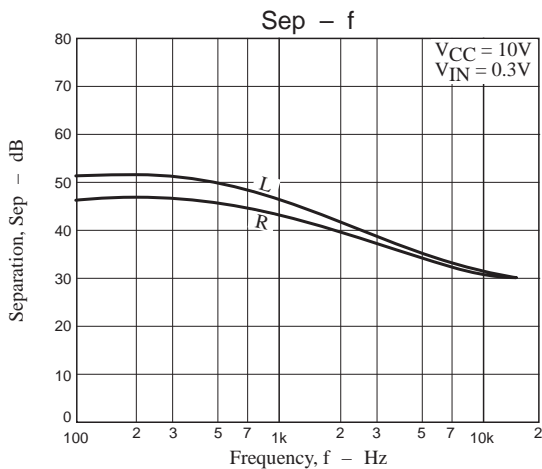

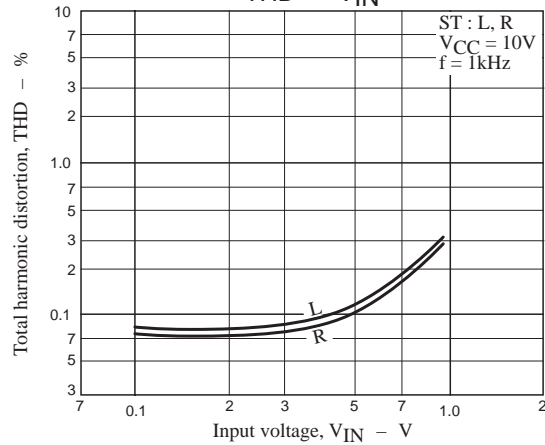
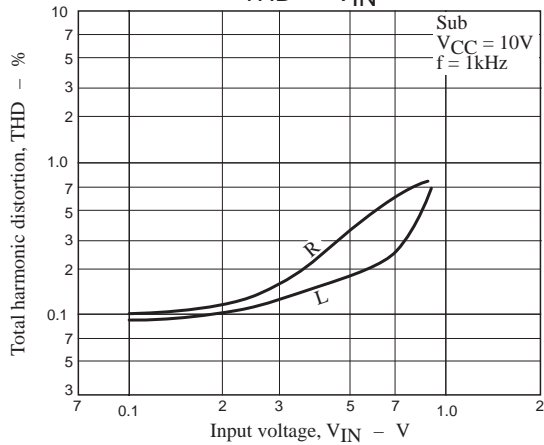
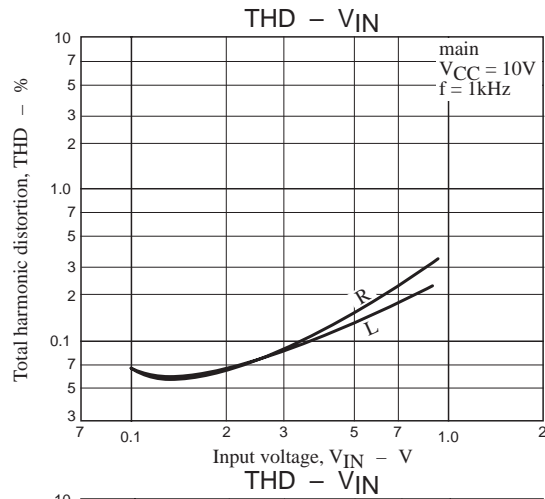
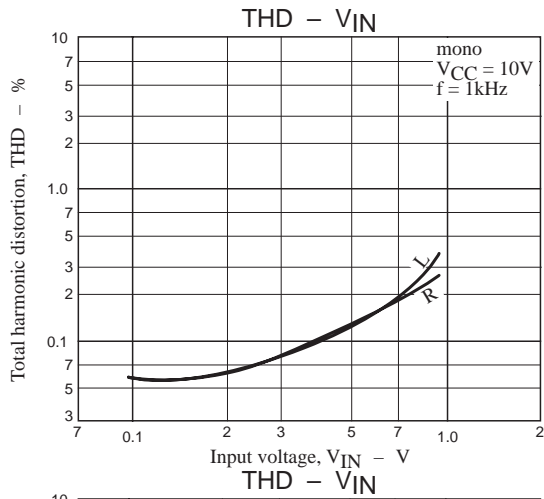

- SANYO Semiconductor Co.,Ltd. assumes no responsibility for equipment failures that result from using products at values that exceed, even momentarily, rated values (such as maximum ratings, operating condition ranges, or other parameters) listed in products specifications of any and all SANYO Semiconductor Co.,Ltd. products described or contained herein.
- SANYO Semiconductor Co.,Ltd. strives to supply high-quality high-reliability products, however, any and all semiconductor products fail or malfunction with some probability. It is possible that these probabilistic failures or malfunction could give rise to accidents or events that could endanger human lives, trouble that could give rise to smoke or fire, or accidents that could cause damage to other property. When designing equipment, adopt safety measures so that these kinds of accidents or events cannot occur. Such measures include but are not limited to protective circuits and error prevention circuits for safe design, redundant design, and structural design.
- In the event that any or all SANYO Semiconductor Co.,Ltd. products described or contained herein are controlled under any of applicable local export control laws and regulations, such products may require the export license from the authorities concerned in accordance with the above law.
- No part of this publication may be reproduced or transmitted in any form or by any means, electronic or mechanical, including photocopying and recording, or any information storage or retrieval system, or otherwise, without the prior written consent of SANYO Semiconductor Co.,Ltd.
- Any and all information described or contained herein are subject to change without notice due to product/technology improvement, etc. When designing equipment, refer to the "Delivery Specification" for the SANYO Semiconductor Co.,Ltd. product that you intend to use.
- Information (including circuit diagrams and circuit parameters) herein is for example only; it is not guaranteed for volume production.
- Upon using the technical information or products described herein, neither warranty nor license shall be granted with regard to intellectual property rights or any other rights of SANYO Semiconductor Co.,Ltd. or any third party. SANYO Semiconductor Co.,Ltd. shall not be liable for any claim or suits with regard to a third party's intellectual property rights which has resulted from the use of the technical information and products mentioned above.

This catalog provides information as of April, 2008. Specifications and information herein are subject to change without notice.