

**LA2806M****Signal Processor and Power Amplifier IC for Telephone Answering Machines****Overview**

The LA2806M is a one-chip voice signal processing IC for single-mechanism answering machines that incorporates the basic functions required for an answering machine as well as the microcontroller interface and analog switches that are needed in order to control those basic functions.

Functions

- Recording preamplifier (with ALC : LINE/MIC input)
- Playback equalizer amplifier
- Recording amplifier (DC bias)
- Analog switches
- Voice-operated switch (VOX) with filter
- Power amplifier ($P_O = 200 \text{ mW}$, $R_L = 8 \Omega$, $V_{CC} = 5 \text{ V}$)
- Line output buffer
- Microcontroller interface

Features

- One-chip voice signal processing for single-mechanism answering machines
- Because the LA2806M incorporates all of the basic functions required for an answering machine and can be controlled by a microcontroller, this IC makes it possible to design an original system
- Built-in power amplifier
- Allows conversation recording mode
- Recording bias and amplifier gain control current can be set separately using external resistors.
- Small package (MFP30S)

Specifications**Maximum Ratings at $T_a = 25^\circ\text{C}$**

Parameter	Symbol	Conditions	Ratings	Unit
Maximum supply voltage	$V_{CC \text{ max}}$, $P.V_{CC \text{ max}}$		9	V
Allowable power dissipation	$P_d \text{ max}$		800	mW
Operating temperature	T_{opr}		-20 to +70	$^\circ\text{C}$
Storage temperature	T_{stg}		-40 to +150	$^\circ\text{C}$

Package Dimensions

unit : mm

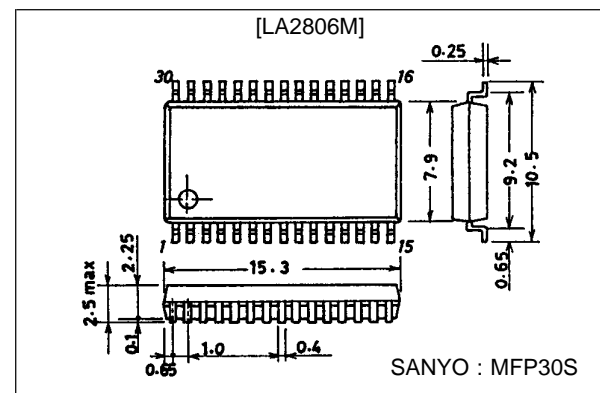
3073A-MFP30S

LA2806M

Operating Conditions at $T_a = 25^\circ\text{C}$

Parameter	Symbol	Conditions	Ratings	Unit
Recommended supply voltage	$V_{CC}, P.V_{CC}$		5	V
Operating supply voltage range	$V_{CC\text{ op}}, P.V_{CC\text{ op}}$		4.5 to 7.5	V
Recommended load resistance	R_L	Power amplifier	8	Ω
Preamplifier input voltage	V_{IN}		0 to 1.0	Vp-p

Operating Characteristics at $T_a = 25^\circ\text{C}, V_{CC} = 5\text{ V}, f = 1\text{ kHz}$

Parameter	Symbol	Conditions	min	typ	max	Unit
Quiescent current	I_{CC}			10	15	mA
[Preamplifier]						
Voltage gain	V_{GC}	-70 dBV input, measured between pins 5 and 8	57	59	61	dB
Total harmonic distortion	THD	-40 dBV input, measured between pins 5 and 8		0.5	1.0	%
ALC turnover input voltage	V_{ALC}	Measured between pins 5 and 8	-68	-64	-60	dBV
ALC output saturation voltage	V_{OS}	-40 dBV input, measured between pins 5 and 8	400	500	625	mVrms
Equivalent input noise voltage	V_{NI}	Input short circuited (internal 2.2 k Ω resistance)		1.5	5.0	μVrms
ALC range	ALC W	From ALC ON to THD = 1 %	40	45		dB
[Playback equalizer amplifier]						
Voltage gain	V_{GE}	-70 dBV input, measured between pins 2 and 8	57	59	61	dB
Total harmonic distortion	THD	-60 dBV input, measured between pins 2 and 8		0.5	1.5	%
Equivalent input noise voltage	V_{NI}	Input short circuited (internal 2.2 k Ω resistance), Flat		1.5	5.0	μVrms
[Recording amplifier]						
Voltage gain	V_{GR}	50 k Ω impedance connected to pin 1 Z_{AC} , measured between pins 10 and 2	-7.0	-4.0	-1.0	dB
Output bias voltage	V_B	100 k Ω resistance connected to pin 1 Z_{DC} , measured on pin 2	0.4	0.8	1.2	V
Total harmonic distortion	THD	-40 dBV preamplifier input		0.5	1.0	%
[LINE amplifier]: $R_L = 1\text{ k}\Omega$						
Voltage gain	V_{GL}	Measured between pins 10 and 22	-1	0	+1	dB
Maximum output voltage	$V_O\text{ max}$	Measured between pins 10 and 22, THD = 1 %	0.6			Vrms
Total harmonic distortion	THD	-40 dBV preamplifier input		0.5	1.0	%
[Power amplifier]: $R_L = 8\text{ k}\Omega$, input pin 20						
Voltage gain	V_{GP}	-30 dBV input, measured between pins 20 and 17	26	28	30	dB
Output voltage	P_O	THD = 10 %	0.2	0.25		W
Total harmonic distortion	THD	$P_O = 100\text{ mW}$		0.5	1.0	%
Input resistance	r_i		10	15	20	k Ω
Ripple rejection ratio	SVRR	$R_g = 0, f_r = 100\text{ Hz}, V_{CCf} = -20\text{ dBV}$	40	50		dB
Output noise voltage	V_{NO}	Input short circuited, Flat		0.1	0.5	mVrms
[Voice-operated switch] Pin 25, $R = 20\text{ k}\Omega$ applied 5 V.						
Sensitivity	V_{OXL}	-23 dBV input, $f = 800\text{ Hz}$			0.3	V
	V_{OXH}	-27 dBV input, $f = 800\text{ Hz}$	4.5	5.0		V
Output ON voltage	V_{sat}	2 V supplied to pin24			0.3	V
[Control pin voltage]						
Pin 26 to 30	V_H	Input high-level voltage		1.5 (or $V_{CC} + 0.3$)		V
	V_L	Input low-level voltage		0	0.8	V
Pin 24 (MUTE)	V_H	Input high-level voltage, supplied via diode	1.5		$V_{CC} - 0.7$	V
[VREF]						
Output voltage	V_{REF}		2.05	2.25	2.45	V

LA2806M

Mode Selection

Mode	REC ON/OFF	LINE ON/OFF	PWR ON/OFF	INPUT		MUTE	SW1/SW11 ICM REC	SW2 ICM PLAY	SW3 LINE	SW4 MIC	SW5 MUTE	SW6 PRE/OGM	SW7 MONI/OGM	SW8 LINE	SW9 PWR	SW10 PRE/EQ
				D1	D0											
MUTE	×	×	×	×	×	HIGH	×	×	×	×	0	×	×	×	×	×
ICM REC	HIGH	LOW	HIGH	HIGH	HIGH	LOW	1	0	1	0	1	1	1	0	1	0
2WAY REC	HIGH	LOW	LOW	HIGH	HIGH	LOW	1	0	1	0	1	1	1	0	0	0
DICT REC	HIGH	LOW	LOW	HIGH	LOW	LOW	1	0	0	1	1	1	1	0	0	0
2WAY BEEP	HIGH	HIGH	HIGH	LOW	HIGH	LOW	1	0	1	0	1	0	1	1	1	0
ICM OUT	LOW	HIGH	HIGH	LOW	LOW	LOW	0	1	0	0	1	1	1	1	1	1
ICM PLAY	LOW	LOW	HIGH	LOW	LOW	LOW	0	1	0	0	1	1	1	0	1	1
OGM REC	LOW	LOW	LOW	HIGH	LOW	LOW	0	0	0	1	1	1	1	0	0	0
OGM CHANGE	LOW	LOW	HIGH	HIGH	HIGH	LOW	0	0	1	0	1	1	1	0	1	0
OGM OUT	LOW	HIGH	HIGH	LOW	HIGH	LOW	0	0	1	0	1	0	1	1	1	0
OGM PLAY	LOW	LOW	HIGH	LOW	HIGH	LOW	0	0	1	0	1	0	1	0	1	0
ROOM MONI	LOW	HIGH	LOW	HIGH	LOW	LOW	0	0	0	1	1	1	1	1	0	0
ROOM OUT	LOW	LOW	HIGH	HIGH	HIGH	LOW	0	0	1	0	1	1	1	0	1	0
VOICE SELE	LOW	HIGH	HIGH	HIGH	HIGH	LOW	0	0	1	0	1	1	0	1	1	0
Conversation recording	HIGH	HIGH	HIGH	HIGH	HIGH	LOW	1	0	1	0	1	1	0	1	1	0

Notes

2WAY BEEP : LINE OUT -6 dB

1 = ON and 0 = OFF (SW1 to SW5, SW8, SW9 and SW11)

Pin Functions

Pin No.	Pin name	Functions
1	BIAS/GAIN	Bias. Recording amplifier gain and recording bias current controled by external resistor.
2	ICM	Incoming head input/output
3	PB NF	Playback amplifier feedback. Receives negative feedback input from PRE OUT (pin 8).
4	GND	Preamplifier ground
5	LINE	Line input
6	MIC	Microphone input
7	PRE NF	Preamplifier feedback. Receives negative feedback input from PRE OUT (pin 8).
8	PRE OUT	Preamplifier/playback amplifier output
9	ALC. CT	Automatic level control time constant adjust input
10	SIG IN	Preamplifier/playback amplifier output signal input
11	OGM/BEEP	Outgoing message/beep input
12	FIL NF	Filter amplifier negative feedback input
13	FIL OUT	Filter amplifier output
14	V. REF	Internal reference voltage output (Approx. 2.2 V)
15	V _{CC}	Preamplifier supply
16	P.GND	Power amplifier ground
17	PWR OUT	Power amplifier output
18	P.V _{CC}	Power amplifier supply
19	D.C	Power amplifier reference voltage output (Approx. 4/9 x P.V _{CC})
20	PWR IN	Power amplifier input
21	PWR MONI	Power amplifier monitor output
22	LINE OUT	Line amplifier output
23	TH	Voice-operated switch (VOX) threshold adjust input. VOX sensitivity can be adjusted by connecting this signal to the V _{REF} pin (pin 14) via a resistor.
24	VOX. C/MUTE	Voice-operated switch (VOX) detection and mute control
25	VOX	Voice-operated switch (VOX) open-collector output
26	D0	Incoming message, line, microphone and outgoing message/beep analog switch control inputs.
27	D1	
28	PWR ON/OFF	Power amplifier ON/OFF analog switch control input
29	LINE ON/OFF	Line amplifier ON/OFF analog switch control input
30	REC ON/OFF	Recording amplifier ON/OFF analog switch control input

IC Usage Notes

- 1) Control Inputs (pin 26 to 30)
Each control input is connected to V_{REF} through a 100 k Ω resistance. The control input threshold level is $V_{REF} \times 3/5$.
- 2) Automatic Level Control (ALC)
The automatic level control circuit operates when the input signal is in the range between -64 dBV to -20 dBV. The output saturation level is 500 mV rms.
- 3) Mute Circuit (pin 24)
The VOX. C/MUTE input controls the mute function.
When it goes HIGH, analog switch SW5 opens, switching off the power amplifier. The power amplifier output goes high impedance and VOX (pin 25) goes LOW.
- 4) V/I Conversion
V/I conversion is performed in order to extract the recording current for DC bias. The conversion gain and the bias current can be controlled by an external resistor connected to pin 1, and current that is equal to the pin 1 output current is output on pin 2.
- 5) Playback Amplifier and Preamplifier Feedback Resistance
As the playback amplifier and preamplifier employ a zero-bias method, the amplifier's output DC level (V_{ODC}) is determined by the feedback resistance (R_{NF}) and the NF pin sink current ($I_i = 15 \mu A$).

$$V_{ODC} = V_{BE} + R_{NF} \times I_i \quad V_{BE} \approx 0.7 V$$
A feedback resistance of 100 k Ω is recommended for both the playback amplifier and the preamplifier to provide an output DC level with sufficient output dynamic range.

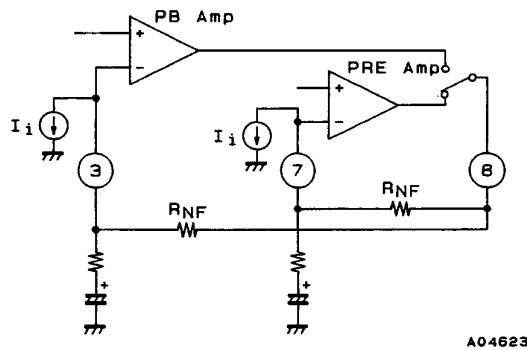

- 6) Filter amplifier
A bandwidth-limiting filter is provided to restrict the VOX circuit input frequency. It can also be used as an inverting amplifier. It has a center frequency of 800 Hz, a gain of 2 and a Q factor of 1.

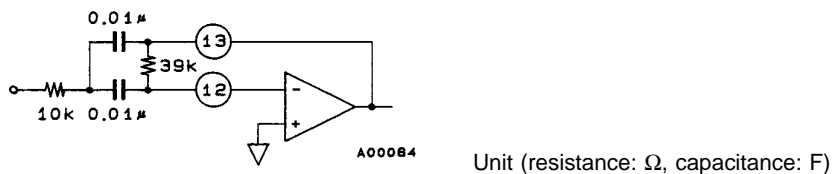

- 7) Voice-operated Switch (VOX)
This switch detects whether anyone is speaking or not by detecting the level of the signal (V13) on the filter amplifier output pin (pin 13).
 $V_{13} \leq -18 \text{ dBV} \dots$ Pin 25 low
The detection level is adjusted by inserting resistor R between TH (pin 23) and V_{REF} (pin 14).
Refer to the diagram below.

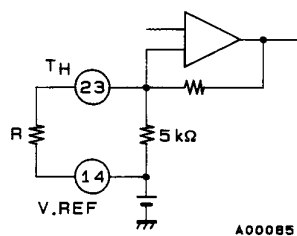

Sample Applications of Operating Modes

- 1) ICM REC (In coming message recording)
 - Recording incoming messages.
 - Memo recording from a remote location (remote control).
- 2) 2WAY REC (Two-way recording)
 - Simultaneously recording conversations.
 - Recording incoming messages.
- 3) DICT REC (Dictaphone)
 - Recording messages using the microphone input (Recording short messages to your family, etc.).
- 4) 2WAY BEEP (Two-way beep)
 - The alarm sound is output on the speaker and is recorded as an incoming message. At the same time, it is output on the line to the calling party.
 - Indicates that the incoming message is being recorded.
 - The line output tone is 6 dB lower than the output level in other modes.
- 5) ICM OUT (Incoming message output)
 - Playing back incoming messages locally.
 - Playing back incoming messages from a remote location.
 - Transferring incoming messages.
 - Playing back dictaphone recordings.
- 6) ICM PLAY (Incoming message playback)
 - Playing back incoming messages.
 - Playing back dictaphone messages.
- 7) OGM REC (Outgoing message recording)
 - Recording outgoing messages. Messages can be transferred under microcomputer control to integrated memory devices.
- 8) OGM CHANGE (Remote outgoing message recording)
 - Re-recording outgoing messages from a remote location.
- 9) OGM OUT (Outgoing message output)
 - Playing back outgoing messages locally.
 - Playing back outgoing messages from a remote location.
- 10) OGM PLAY (Outgoing message playback)
 - Playing back and confirming outgoing messages.
- 11) ROOM MONI (Remote microphone monitoring)
 - Monitoring microphone input from a remote location.
- 12) ROOM OUT (Remote speaker output)
 - Output messages through the loudspeaker from a remote location.
- 13) VOICE SELE (Voice monitoring)
 - Sending output messages, and at the same time monitoring the caller's voice through the loudspeaker.
- 14) Conversation REC (Conversation recording)
 - Simultaneously recording incoming messages and playing back the outgoing message.

IC Usage Notes

- 1) Printed Circuit Board
When designing a printed circuit board, the GND line connected to pin 4 should be thick and short. Common impedance may lead to additional distortion.
- 2) Power Amplifier
Polyester film capacitors should be used as the oscillation prevention capacitor between output pin 17 and GND, as they have better temperature and frequency characteristics than electrolytic capacitors. Aluminium electrolytic capacitors and ceramic capacitors may cause oscillation at low temperatures.
- 3) Switching Noise
Switching noise can be eliminated by applying a LOW-level pulse greater than 10 ms to PWR ON/OFF pin 28 while the preamplifier is being switched.

LA2806M

- 4) If the IC is used near the maximum ratings, even a slight variation in conditions may cause the maximum ratings to be exceeded, thereby leading to breakdown. Allow an ample margin of variation for supply voltage etc. and use the IC in the range where the maximum ratings are not exceeded.
- 5) Short Circuits Between Pins
The circuit board should be examined for short circuits between pins before initial power-up to prevent damage to the device when voltage is applied.
- 6) Short-circuit Load
Short circuiting the LA2806M output for an extended period while the power is on can damage the device.
- 7) Playback Amplifier and Preamp Feedback Resistance
As the playback amplifier and preamplifier employ a zero-bias method, the amplifier's output DC level (V_{ODC}) is determined by the feedback resistance (R_{NF}) and the NF pin sink current ($I_i = 15 \mu\text{A}$).
$$V_{ODC} = V_{BE} + R_{NF} \times I_i \quad V_{BE} \cong 0.7 \text{ V}$$
A feedback resistance of $100 \text{ k}\Omega$ is recommended for both the playback amplifier and the preamplifier to provide an output DC level with sufficient output dynamic range.

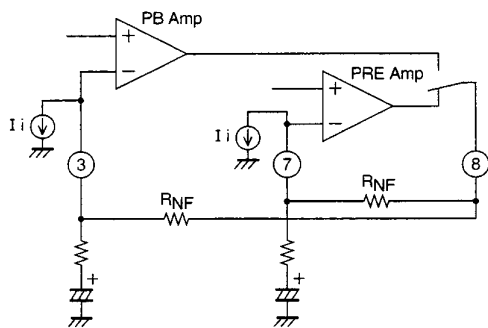

LA2806M

Sample Application Circuit

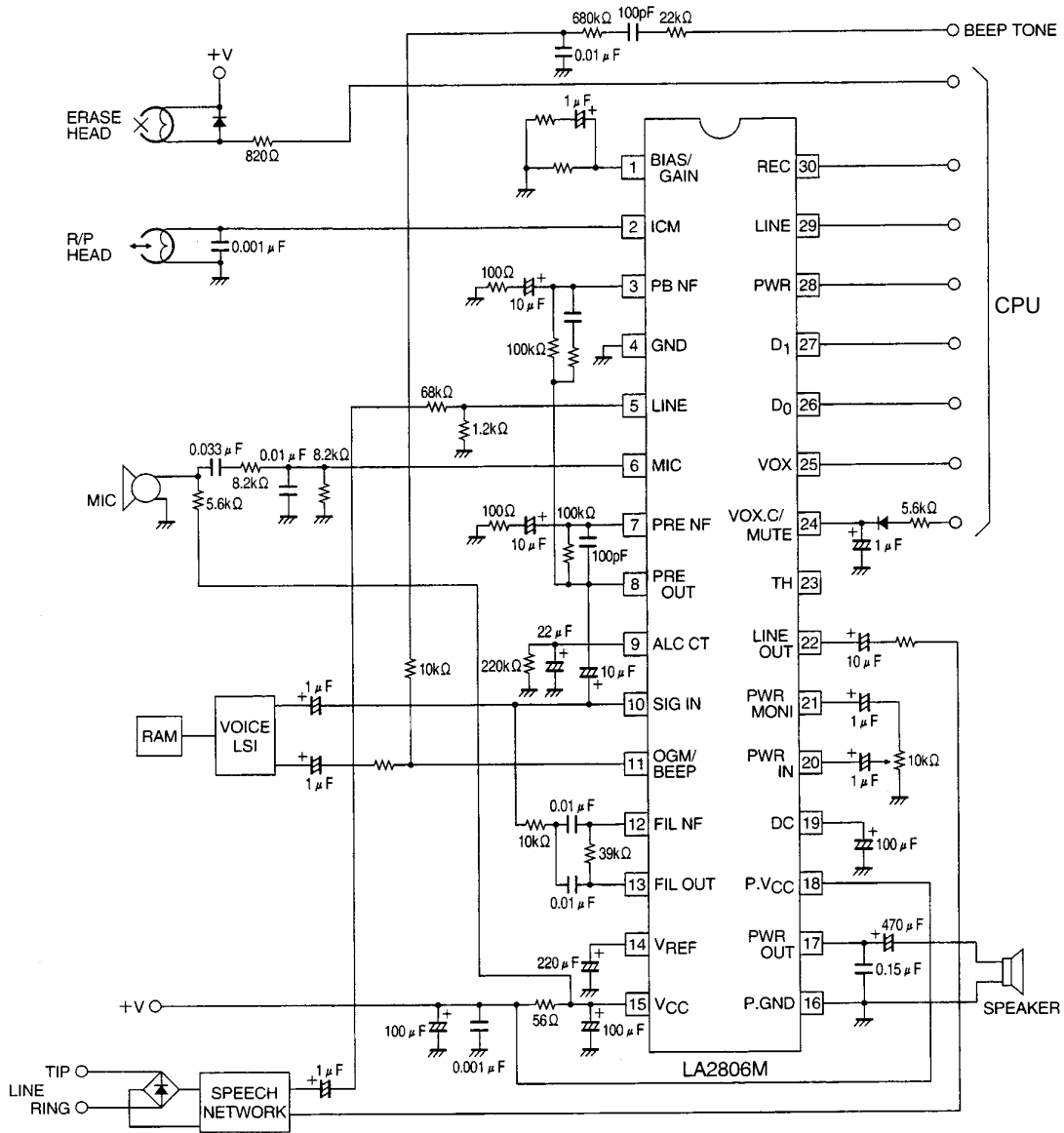

A09250

LA2806M

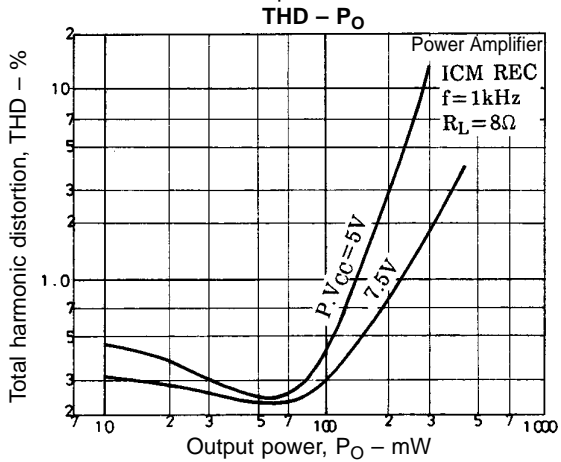
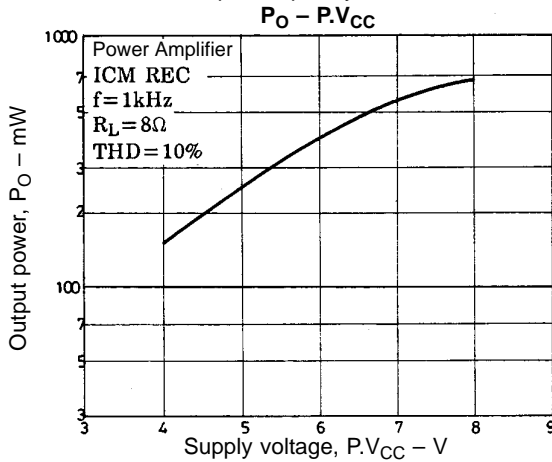
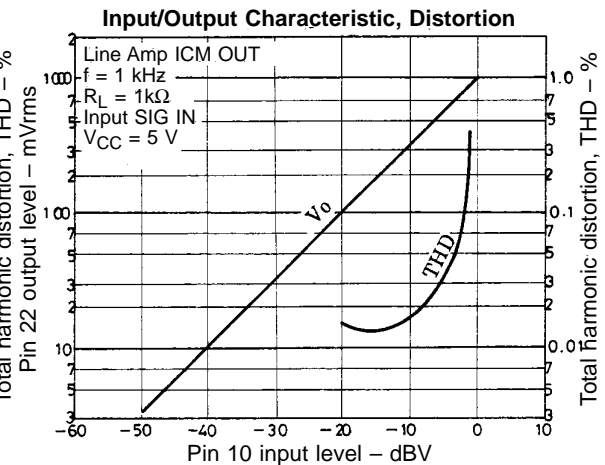
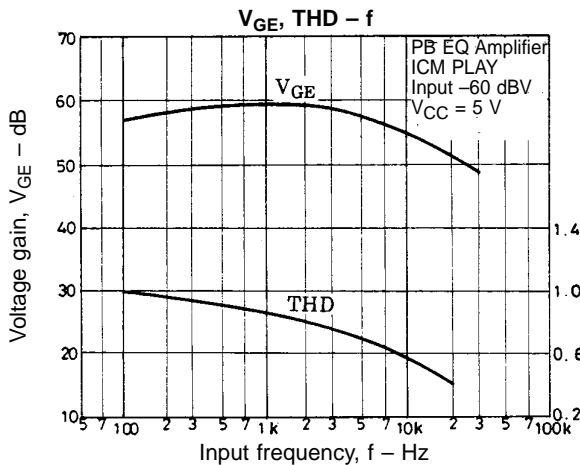
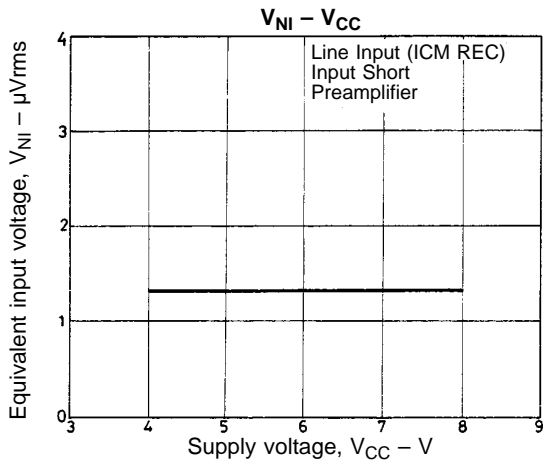
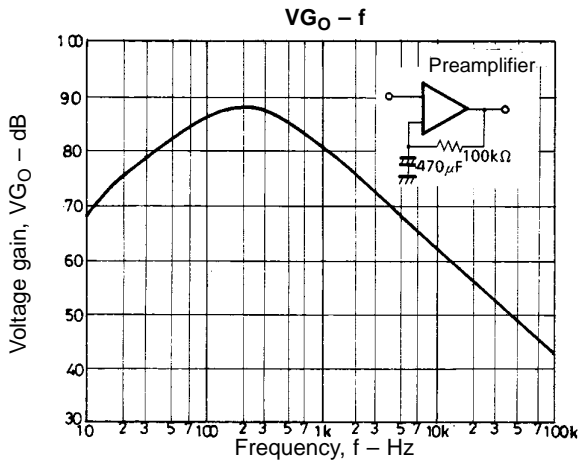
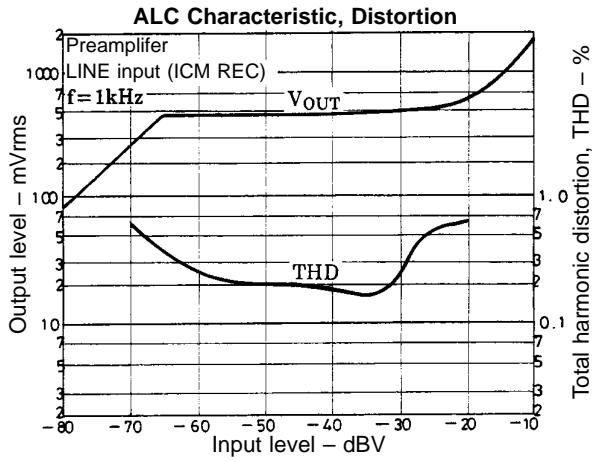
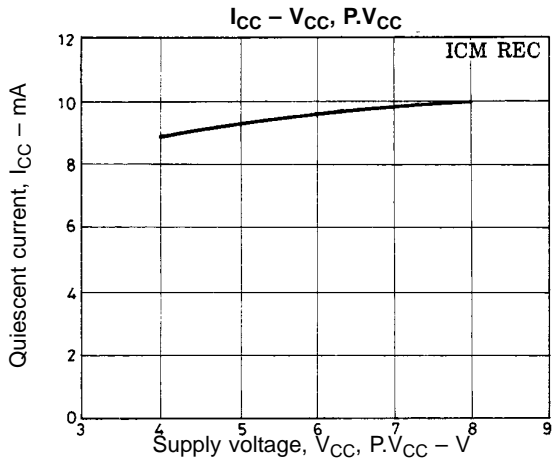

LA2806M

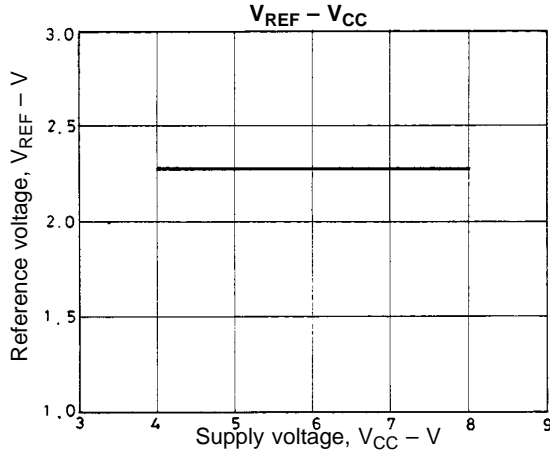
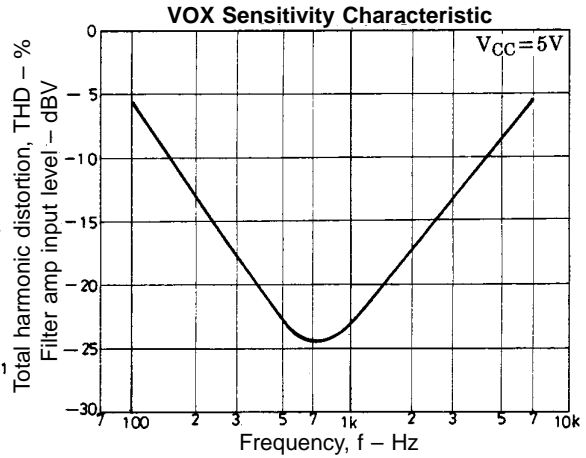
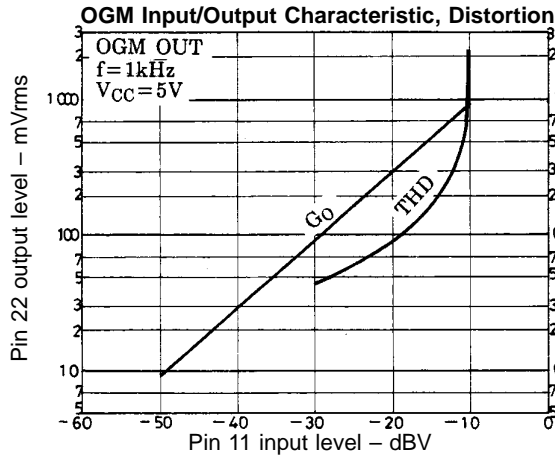
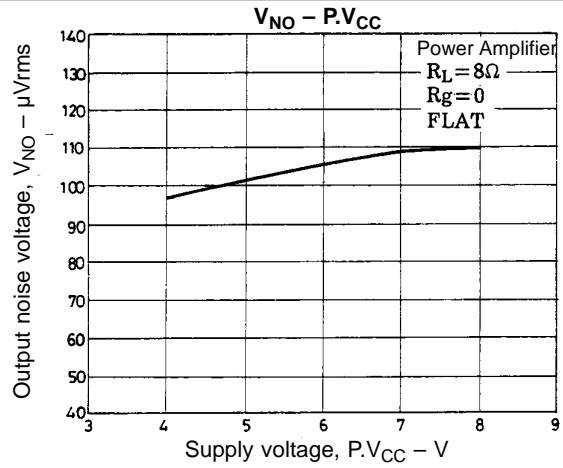
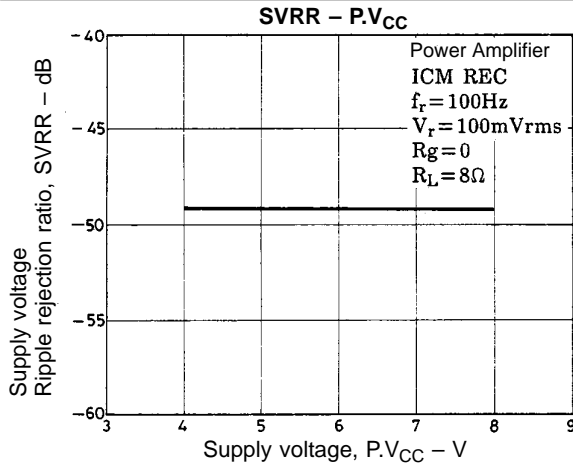

- No products described or contained herein are intended for use in surgical implants, life-support systems, aerospace equipment, nuclear power control systems, vehicles, disaster/crime-prevention equipment and the like, the failure of which may directly or indirectly cause injury, death or property loss.
- Anyone purchasing any products described or contained herein for an above-mentioned use shall:
 - ① Accept full responsibility and indemnify and defend SANYO ELECTRIC CO., LTD., its affiliates, subsidiaries and distributors and all their officers and employees, jointly and severally, against any and all claims and litigation and all damages, cost and expenses associated with such use:
 - ② Not impose any responsibility for any fault or negligence which may be cited in any such claim or litigation on SANYO ELECTRIC CO., LTD., its affiliates, subsidiaries and distributors or any of their officers and employees jointly or severally.
- Information (including circuit diagrams and circuit parameters) herein is for example only; it is not guaranteed for volume production. SANYO believes information herein is accurate and reliable, but no guarantees are made or implied regarding its use or any infringements of intellectual property rights or other rights of third parties.

This catalog provides information as of October, 1997. Specifications and information herein are subject to change without notice.