

SYNC SEPARATOR I

The KA2605 is a monolithic integrated circuit designed for all kinds of sync separation from composite video signals. Regardless of the input signal (C. Video Signal) variations, the KA2605 can generate fully stabilized sync pulses.

FUNCTIONS

- Phase Inverters.
- Horizontal Synchronization Separators.
- Vertical Synchronization Separators.
- Composite Synchronization Separators.
- Low Pass Filter Included.
- Open Collector Output.

FEATURES

- Requiring few external components.
- Wide supply voltage range: $V_{CC} = 8V - 15V$
- All kinds of sync separation in composite video signals.
- Usable for a basis signal in digital systems.
- Separated synchronization are accurate and stable.

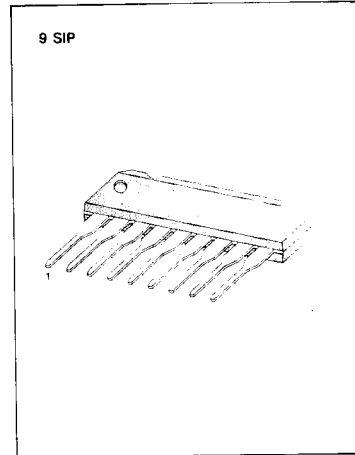

ORDERING INFORMATION

Device	Package	Operating Temperature
KA2605	9 SIP	- 20 ~ + 80°C

BLOCK DIAGRAM

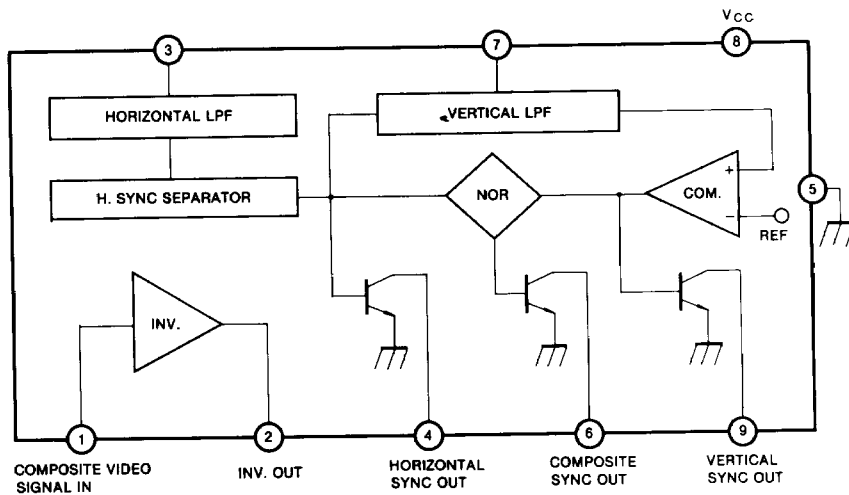

Fig. 1

ABSOLUTE MAXIMUM RATINGS (Ta = 25°C)

Characteristic	Symbol	Value	Unit
Supply Voltage	V _{CC}	15	V
Power Dissipation	P _d	500	mW
Operating Temperature	T _{opr}	-20 ~ +80	°C
Storage Temperature	T _{stg}	-65 ~ +150	°C

ELECTRICAL CHARACTERISTICS (Ta = 25°C, V_{CC} = 12V)

Characteristic	Symbol	Test Pin	Test Condition	Min	Typ	Max	Unit
Supply Current	I _{CC}	8	SW1, SW2: OFF	16	22	28	mA
Input Offset Voltage	V _{ofs}	1	V _{CC} = 12V SIG-1:2V _{p-p} C. VIDEO	2.5	4.5	8.5	V
Input Signal Voltage	V _{in}	1	V _{CC} = 12V V _{ofs} = 3.5V-8V	0.6	2.0	3.5	V _{p-p}
Horizontal Sync Delay	T _{HD}	4	SW1, SW2: ON SIG-1:2V _{p-p} C. VIDEO	0	0.4	0.5	μS
Horizontal Sync Width	D _H	4	SW1, SW2: ON SIG-1:2V _{p-p} C. VIDEO	4.4	4.6	4.9	μS
Vertical Sync Delay	T _{VD}	9	SW1, SW2: ON SIG-1:2V _{p-p} C. VIDEO	0	9	12	μS
Vertical Sync Width	D _V	9	SW1, SW2: ON SIG-1:2V _{p-p} C. VIDEO	185	190	195	μS
Horizontal Sync Delay in Composite Sync	T _{CHD}	6	SW1, SW2: ON SIG-1:2V _{p-p} C. VIDEO	0	0.4	0.5	μS
Horizontal Sync Width in Composite Sync	D _{CH}	6	SW1, SW2: ON SIG-1:2V _{p-p} C. VIDEO	4.4	4.6	4.9	μS
Vertical Sync Delay in Composite Sync	T _{CVD}	6	SW1, SW2: ON SIG-1:2V _{p-p} C. VIDEO	0	0.4	1.0	μS
Vertical Sync Width in Composite Sync	D _{CV}	6	SW1, SW2: ON SIG-1:2V _{p-p} C. VIDEO	195	200	205	μS

* This spec. is used 10:1 probe. Measure point is 2V of output.

NOTE (Ta = 25°C)

Supply Voltage (V _{CC})	Input Signal Voltage (V _{in})	Input Offset Voltage (V _{ofs})
8V	0.6V _{p-p}	2.0V – 5.0V
	2.0V _{p-p}	2.0 – 5.5V
	3.5V _{p-p}	3.0V – 5.5V
12V	0.6V _{p-p}	2.0V – 8.0V
	2.0V _{p-p}	2.5V – 8.5V
	3.5V _{p-p}	3.5V – 8.5V
15V	0.6V _{p-p}	2.5V – 9.0V
	2.0V _{p-p}	3.0V – 10.5V
	3.5V _{p-p}	4.0V – 10.5V

PIN ASSIGNMENT

Pin 1: Composite Video Signal In
 Pin 2: Inverter Out
 Pin 3: Horizontal Low Pass Filter Out
 Pin 4: Horizontal Synchronization Out (Open Collector)

Pin 5: Ground
 Pin 6: Composite Synchronization Out (Open Collector)
 Pin 7: Vertical Low Pass Filter
 Pin 8: V_{CC} (+ 12V)
 Pin 9: Vertical Synchronization Out (Open Collector)

TEST CIRCUIT

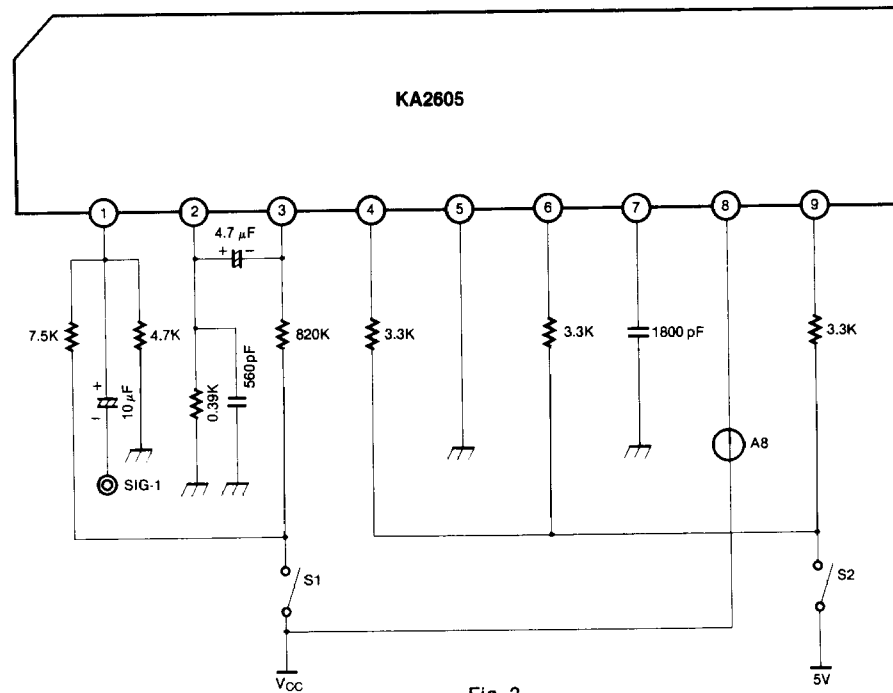

Fig. 2

NOTE

INPUT SIGNAL: Fig. 3
 V_{CC} : DC 12V

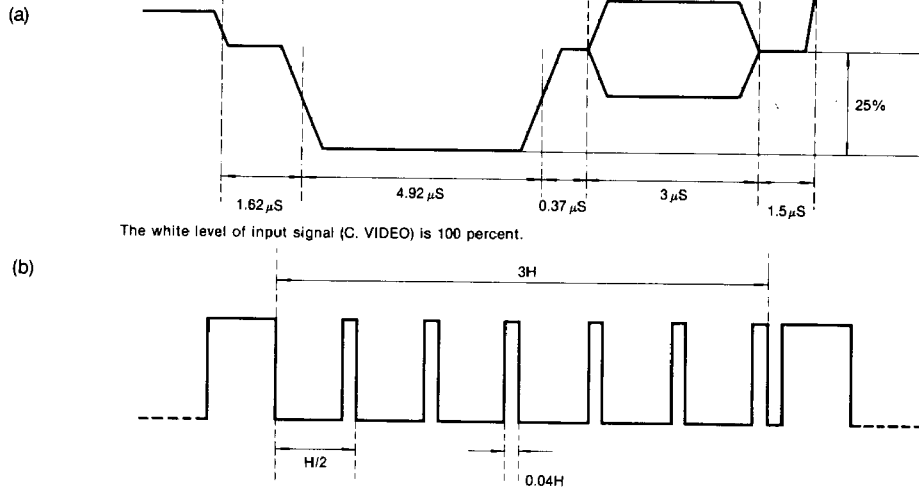

Fig. 3 $2V_{pp}$ Positive composite video signal
 (a) Horizontal sync pulse.
 (b) Vertical sync pulse. H equals $63.5 \mu S$.

TYPICAL APPLICATION CIRCUIT

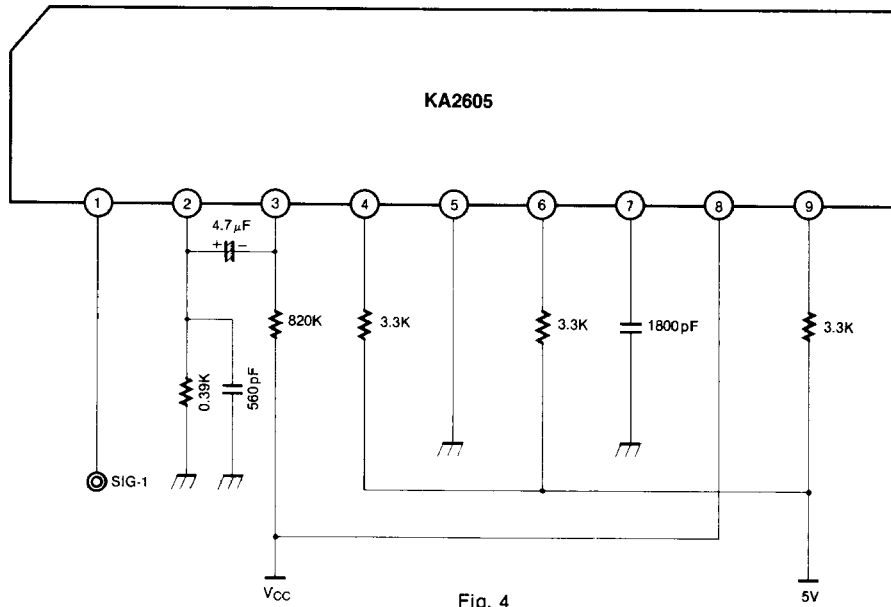

Fig. 4