

Features

- Single chip solution for satellite tuner LNA and AGC
- Provides for 30 dB minimum AGC
- Low DSB NF at maximum gain
- High signal handling at minimum gain
- Provides differential output drive
- ESD protection (Normal ESD handling procedures should be observed)

Applications

- Satellite receiver systems
- Data communications systems
- Master Antennae Distribution Systems

Ordering Information

SL1914A/KG/MP1S
SL1914A/KG/MP1T

Description

The SL1914 is a wideband LNA with AGC designed primarily for application in satellite tuner front ends, offering high signal handling capability with low noise figure compatible with most common tuner input requirements.

The SL1914 is optimised to complement the SL1925, ZIF quadrature downconverter, integrating all the active RF circuitry within the tuner, in a highly compact, efficient solution, and offering a full 1-45 MS/s tuner capability.

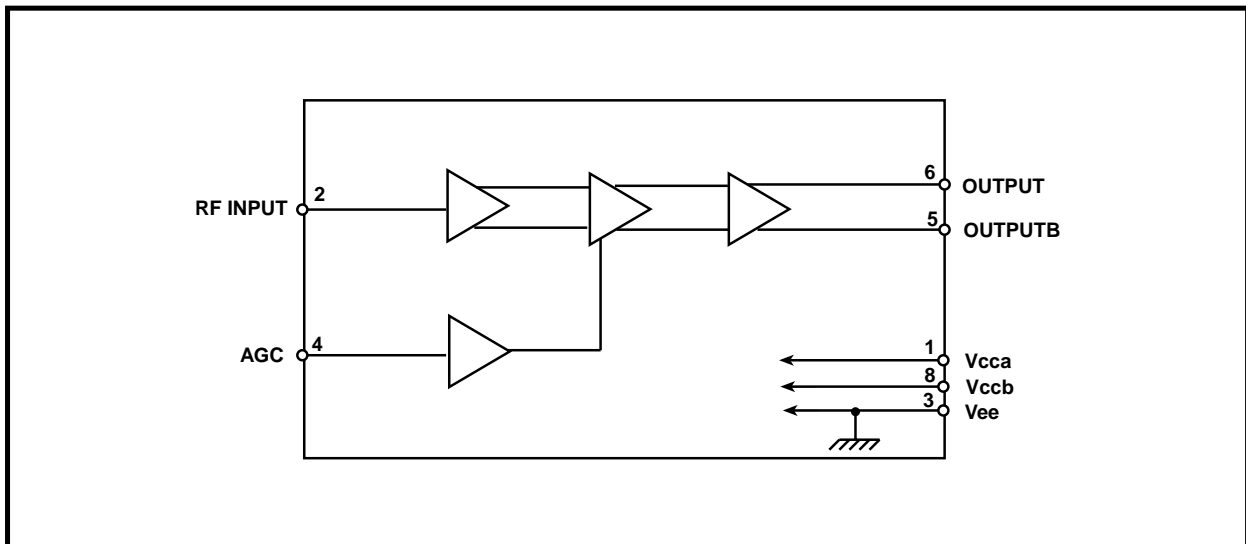

Figure 1 Block Diagram

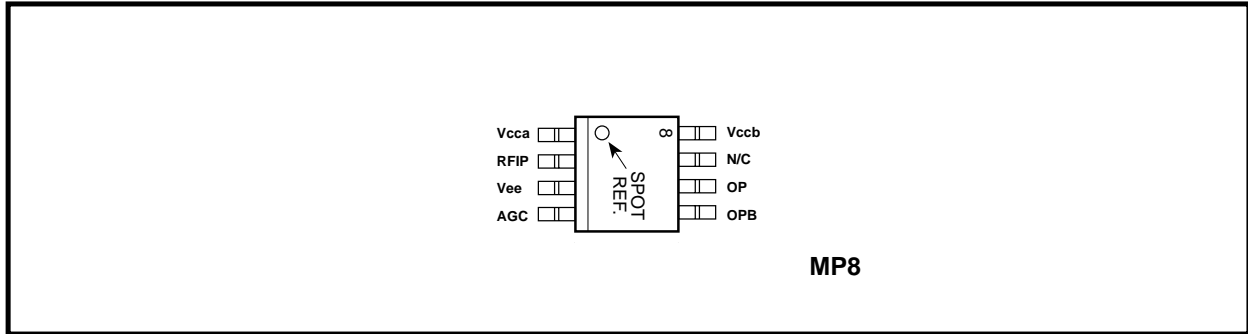

Figure 2 Pin Connections

Quick Reference Data

Characteristic		Units
Operating frequency	950 - 2150	MHz
Input DSB NF at max gain	9	dB
Maximum conversion gain	20	dB
Minimum conversion gain	-10	dB
IIP3 _{2T}	117	dBμV
IIP2 _{2T}	127	dBμV

Table 1

Functional Description

The SL1914 is a bipolar, low noise AGC amplifier designed primarily for application in satellite tuner front ends. It contains a low noise input amplifier, an AGC stage with a minimum of 30dB of gain control and a 75 Ohm output drive. It replaces all active circuitry in conventional architectures.

The typical key performance numbers under nominal load ambient and supply conditions are contained in table headed Quick Reference Data.

Electrical Characteristics

$T_{amb} = -20^{\circ}\text{C}$ to $+70^{\circ}\text{C}$, $V_{ee} = 0\text{V}$, $V_{cc} = 5\text{V} \pm 5\%$, These characteristics are guaranteed by either production test or design. They apply within the specified ambient temperature and supply voltage unless otherwise stated.

Characteristic	Pin	Value			Units	Conditions
		Min	Typ	Max		
Supply current	1, 8		110	150	mA	AGC = 4V
Operating range		950		2150	MHz	
Input impedance	2		75		Ω	
IF input return loss	2	8			dB	
Input DSB NF	2		9	11	dB	Maximum gain, AGC = 0.75V
Variation in NF with gain setting				-1	dB/dB	
Conversion gain minimum				-10	dB	Differential power gain into 75Ω $V_{agc} = 4\text{V}$ See note 1.
Conversion gain maximum		21			dB	$V_{agc} = 0.75\text{V}$
Gain variation within channel				+0.5	dB	AGC monotonic from Vee to Vcc Maximum channel bandwidth of 54MHz, within range 950 - 2150MHz
Input referred 1 dB gain compression	2	107			dB μV	Minimum specified gain setting
Input referred IP3	2	117			dB μV	Minimum specified gain setting, two tones at 99dB μV
Input referred IP2	2	125			dB μV	Minimum specified gain setting, two tones at 99dB μV
Variation in second and third order intermodulation intercept points with gain setting				-1	dB/dB	
AGC control slope variation	4			4:1		
AGC control input current	4			± 350	μA	
Output impedance	5, 6		75		Ω	
Output return loss	5, 6	6			dB	

Note 1: The AGC voltage should not exceed 4V.

Absolute Maximum Ratings

All voltages referred to Vee at 0V.

Characteristics	Min	Max	Unit	Conditions
Supply voltage	-0.3	7	V	Transient condition only Except AGC (pin 4)
IFIN and IFINB input voltage		117	dB μ V	
All I/O port DC offset	-0.3	VCC+0.3	V	
AGC input DC offset	-0.3	4	V	
Storage temperature	-55	150	$^{\circ}$ C	
Junction temperature		150	$^{\circ}$ C	
Package thermal resistance, chip to case		39.8	$^{\circ}$ C/W	
Package thermal resistance, chip to ambient		120	$^{\circ}$ C/W	
Power consumption at 5.25V		790	mW	
ESD protection	2		kV	
				Mil std-883 latest revision method 3015 class 1

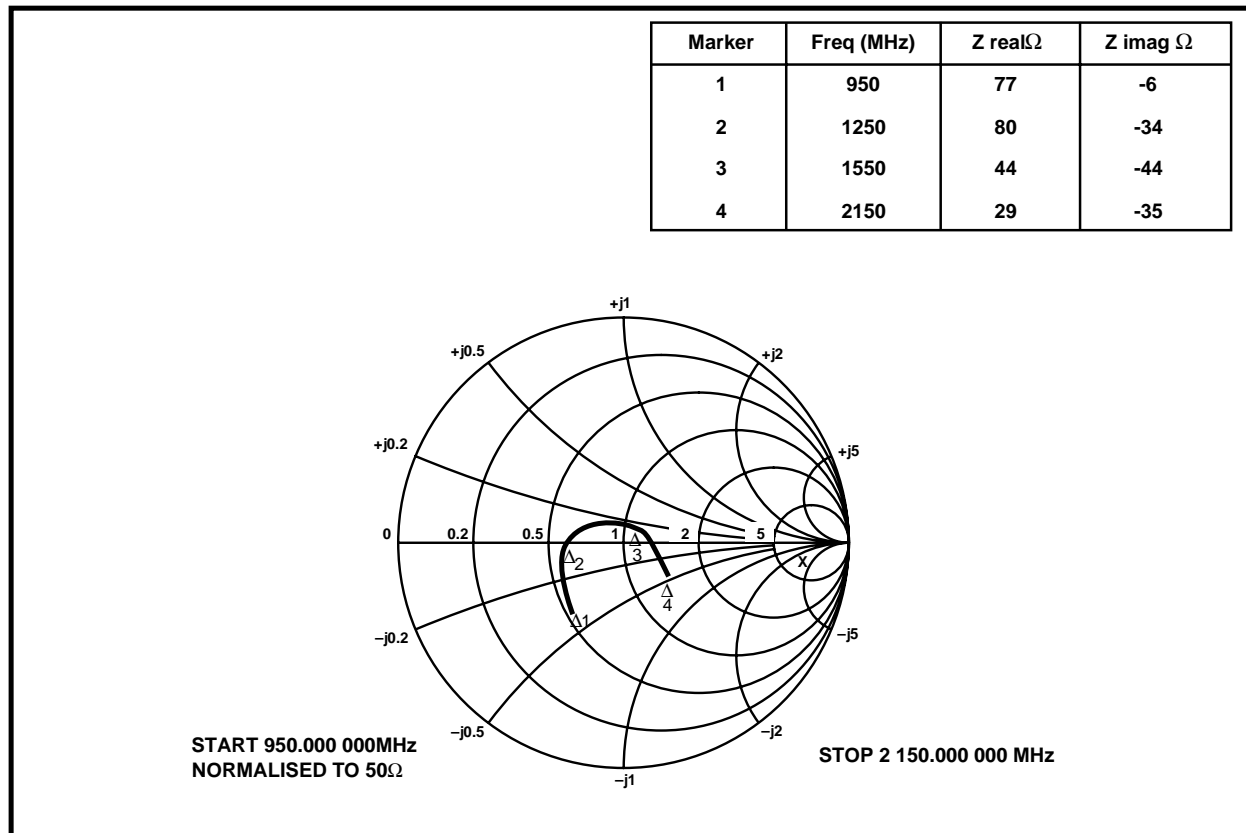

Figure 3 Input impedance (typical)

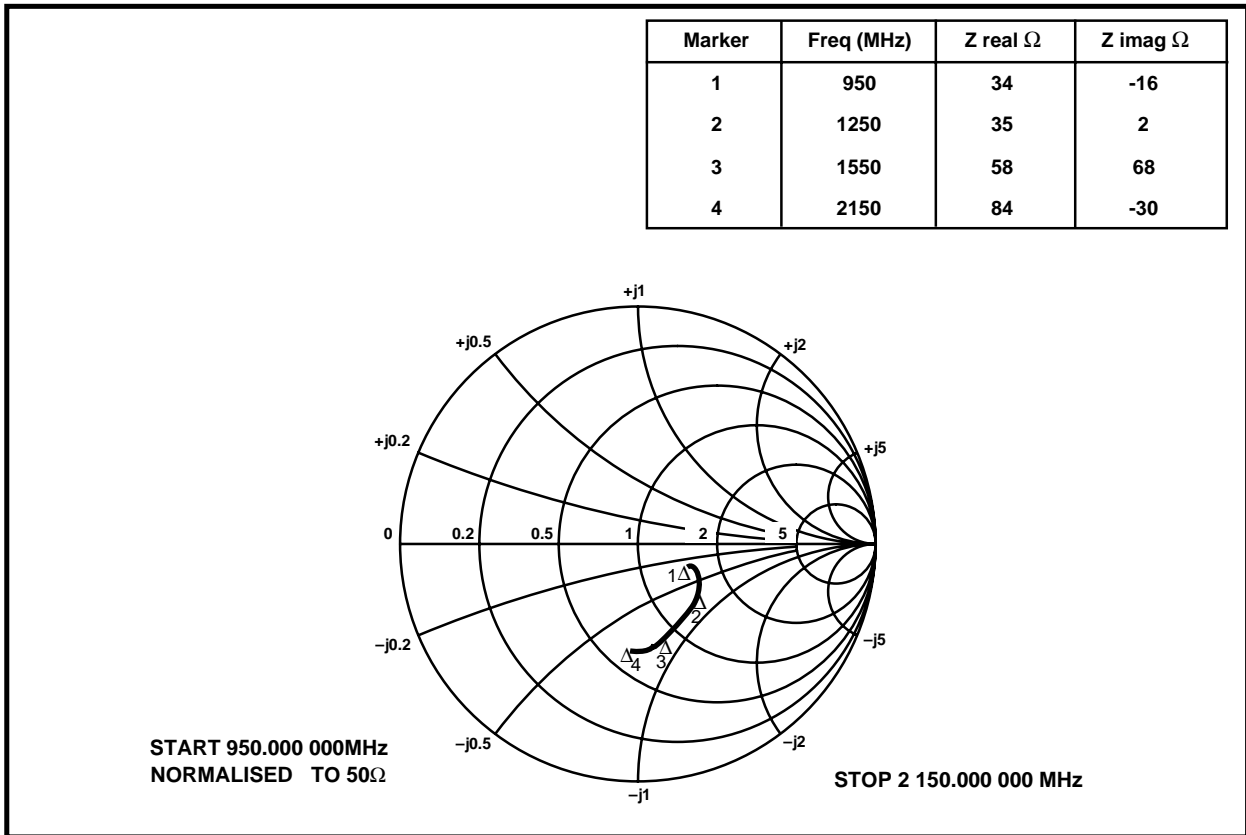

Figure 4 Output impedance (typical)

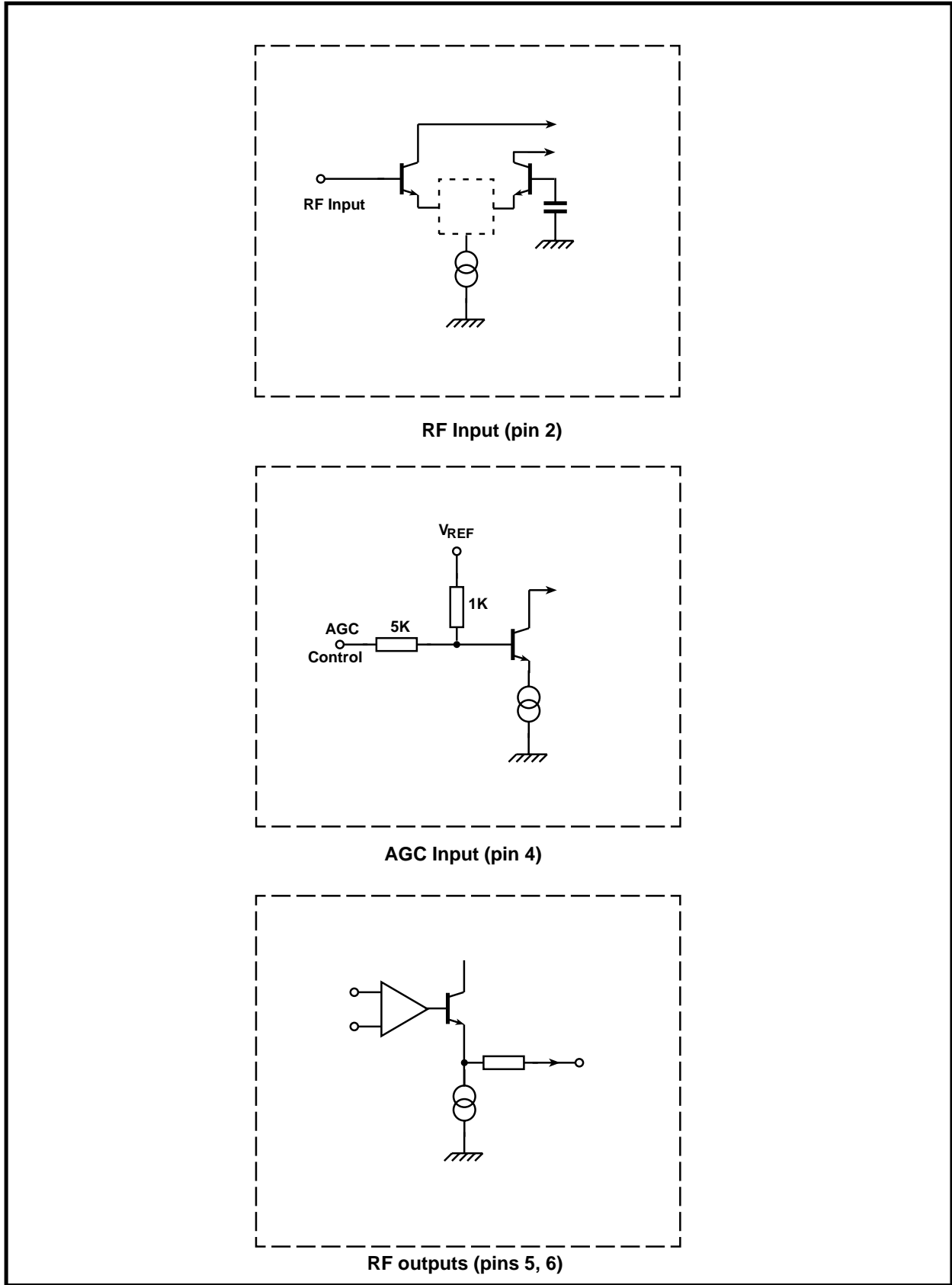

Figure 6 Input/Output interface circuit

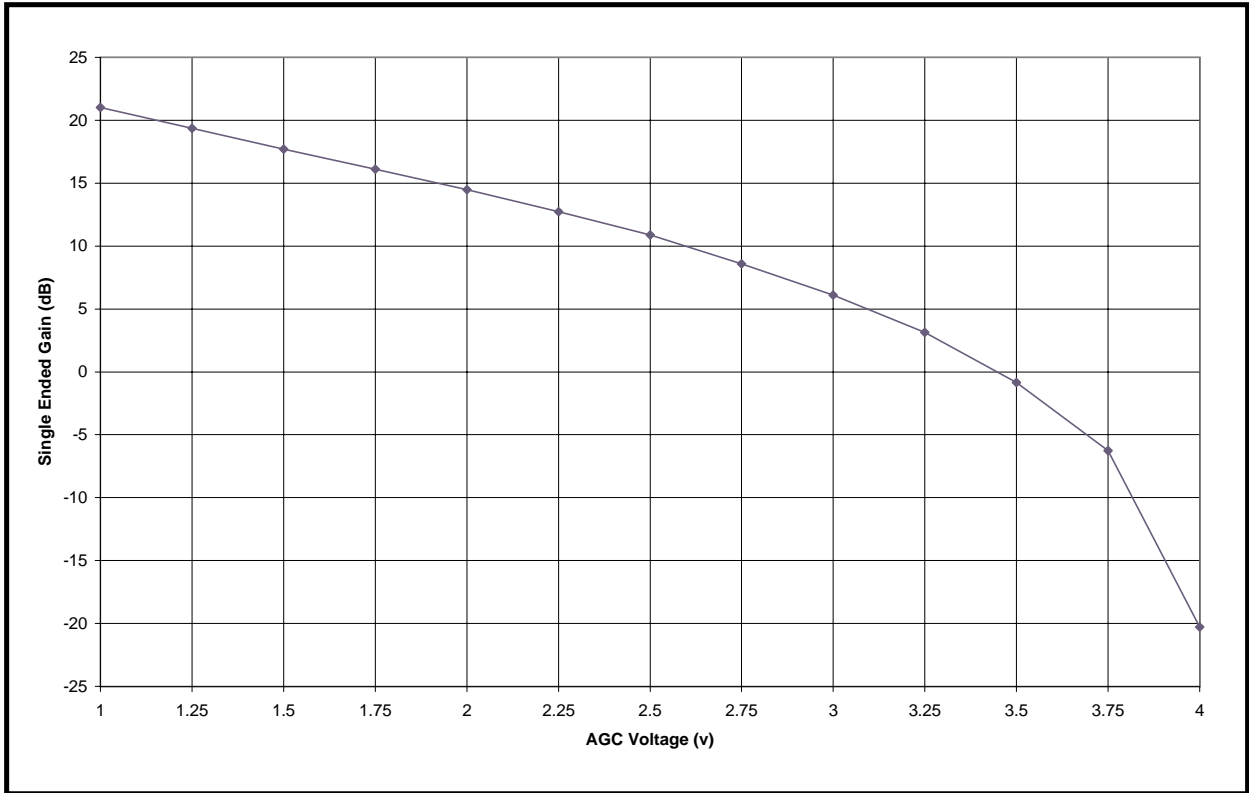
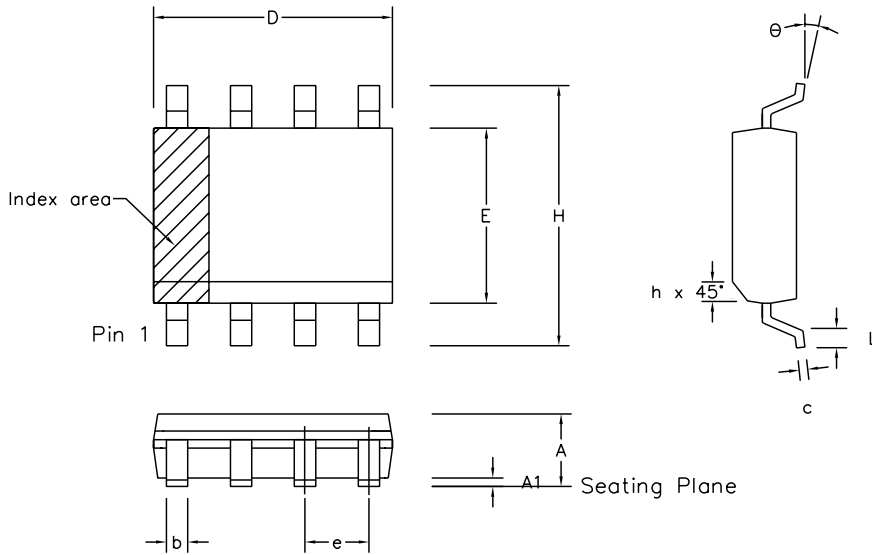



Figure 5 gain variation with AGC voltage (typical)



	Min mm	Max mm	Min inch	Max inch
A	1.35	1.75	0.053	0.069
A1	0.10	0.25	0.004	0.010
D	4.80	5.00	0.189	0.197
H	5.80	6.20	0.228	0.244
E	3.80	4.00	0.150	0.157
L	0.40	1.27	0.016	0.050
e	1.27 BSC		0.050 BSC	
b	0.33	0.51	0.013	0.020
c	0.19	0.25	0.008	0.010
Ø	0°	8°	0°	8°
h	0.25	0.50	0.010	0.020
Pin Features				
N	8		8	
Conforms to JEDEC MS-012AA Iss. C				

Notes:

1. The chamfer on the body is optional. If not present, a visual index feature, e.g. a dot, must be located within the cross-hatched area.
2. Controlling dimensions are in inches.
3. Dimension D do not include mould flash, protusion or gate burrs. These shall not exceed 0.006" per side.
4. Dimension E1 do not include inter-lead flash or protusion. These shall not exceed 0.010" per side.
5. Dimension b does not include dambar protusion / intrusion. Allowable dambar protusion shall be 0.004" total in excess of b dimension.

© Zarlink Semiconductor 2002 All rights reserved.							Package Code	DC
ISSUE	1	2	3	4	5		Previous package codes	Package Outline for 8 lead SOIC (0.150" Body width)
ACN	6745	201936	202595	203705	212424		MP / S	
DATE	5Apr95	27Feb97	12Jun97	9Dec97	22Mar02			
APPRD.								GPD00010



**For more information about all Zarlink products
visit our Web Site at
www.zarlink.com**

Information relating to products and services furnished herein by Zarlink Semiconductor Inc. trading as Zarlink Semiconductor or its subsidiaries (collectively "Zarlink") is believed to be reliable. However, Zarlink assumes no liability for errors that may appear in this publication, or for liability otherwise arising from the application or use of any such information, product or service or for any infringement of patents or other intellectual property rights owned by third parties which may result from such application or use. Neither the supply of such information or purchase of product or service conveys any license, either express or implied, under patents or other intellectual property rights owned by Zarlink or licensed from third parties by Zarlink, whatsoever. Purchasers of products are also hereby notified that the use of product in certain ways or in combination with Zarlink, or non-Zarlink furnished goods or services may infringe patents or other intellectual property rights owned by Zarlink.

This publication is issued to provide information only and (unless agreed by Zarlink in writing) may not be used, applied or reproduced for any purpose nor form part of any order or contract nor to be regarded as a representation relating to the products or services concerned. The products, their specifications, services and other information appearing in this publication are subject to change by Zarlink without notice. No warranty or guarantee express or implied is made regarding the capability, performance or suitability of any product or service. Information concerning possible methods of use is provided as a guide only and does not constitute any guarantee that such methods of use will be satisfactory in a specific piece of equipment. It is the user's responsibility to fully determine the performance and suitability of any equipment using such information and to ensure that any publication or data used is up to date and has not been superseded. Manufacturing does not necessarily include testing of all functions or parameters. These products are not suitable for use in any medical products whose failure to perform may result in significant injury or death to the user. All products and materials are sold and services provided subject to Zarlink's conditions of sale which are available on request.

Purchase of Zarlink's I²C components conveys a licence under the Philips I²C Patent rights to use these components in an I²C System, provided that the system conforms to the I²C Standard Specification as defined by Philips.

Zarlink, ZL and the Zarlink Semiconductor logo are trademarks of Zarlink Semiconductor Inc.

Copyright 2003, Zarlink Semiconductor Inc. All Rights Reserved.

TECHNICAL DOCUMENTATION - NOT FOR RESALE