

\*Customer:

# SPECIFICATION

<b>ITEM</b>	<b>TOP LED DEVICE</b>
<b>MODEL</b>	<b>SSC-HYT722</b>

[Contents]

1. Features -----	2
2. Application -----	2
3. Absolute Maximum Ratings -----	2
4. Electro-optical Characteristics -----	3
5. Rank of HYT722 -----	4
6. Soldering Profile -----	5
7. Outline Dimension And Material -----	6
8. Packing -----	7
9. Reel Packing Structure -----	8
10. Lot Number -----	9
11. Precaution for Use -----	10
12. Characteristic Diagram -----	11

**CUSTOMER**

Checked by	Approved by

**SUPPLIER**

Drawn by	Checked by	Approved by

## 1. Features

- Pb-free Reflow Soldering application
- RoHS Compliant
- Material : AlInGaP
- Suitable for all SMT assembly methods ; Suitable for all soldering methods
- White colored SMT package and colorless clear window
- Encapsulating Resin : Epoxy Resin

## 2. Application

- Indoor and outdoor displays
- LCD Backlights etc.
- Yellow – displays
- Automotive
- Signage and Channel letter
- Indicator

## 3. Absolute Maximum Ratings <sup>\*1</sup>

( $T_a=25^{\circ}\text{C}$ )

Parameter	Symbol	Value	Unit
Power Dissipation	$P_d$	252	mW
Forward Current	$I_F$	90	mA
Forward Peak Surge Current (per die)	$I_{FM}^{*2}$	100	mA
Reverse Voltage (per die)	$V_R$	5	V
Operating Temperature	$T_{opr}$	-30 ~ +85	°C
Storage Temperature	$T_{stg}$	-40 ~ +100	°C

\*1 Care is to be taken that power dissipation does not exceed the absolute maximum rating of the product.

\*2  $I_{FM}$  was measured at  $T_W \leq 1\text{msec}$  of pulse width and  $D \leq 1/10$  of duty ratio.

#### 4. Electro-Optical Characteristics

( $T_a=25^{\circ}\text{C}$ )

Parameter	Symbol	Condition	Min	Typ	Max	Unit
Forward Voltage (per die)	$V_F$	$I_F=20\text{ mA}$	1.6	2.2	2.8	V
Reverse Current (per die)	$I_R$	$V_R=5\text{V}$	-	-	10	$\mu\text{A}$
Luminance Intensity *1	$I_V$	$I_F=60\text{ mA}$	950	1400	1700	mcd
Luminance Flux	$\Phi_V$	$I_F=60\text{ mA}$	-	4	-	lm
Dominant Wavelength	$\lambda_d$	$I_F=60\text{ mA}$	582	590	598	nm
Peak Wavelength	$\lambda_p$	$I_F=60\text{ mA}$	-	593	-	nm
Spectral Bandwidth	$\Delta\lambda$	$I_F=60\text{ mA}$	-	18	-	nm
Viewing Angle *2	$2\theta_{1/2}$	$I_F=60\text{ mA}$	-	120	-	deg
Optical Efficiency	$\eta_{opt}$	$I_F=60\text{ mA}$	-	30	-	lm/W

\*1 The luminous intensity  $I_V$  was measured at the peak of the spatial pattern which may not be aligned with the mechanical axis of the LED package. Luminous Intensity Measurement allowance is  $\pm 10\%$ .

\*2  $2\theta_{1/2}$  is the off-axis where the luminous intensity is 1/2 of the peak intensity.  
[Note] All measurements were made under the standardized environment of SSC.

## 5. Rank of HYT722

### ■ Rank Name Table

$X_1$	$X_2$	$X_3$
Iv	$\lambda d$	Vf

### ■ Luminous Intensity [Iv]

Rank Name	Iv (mcd)	
	MIN	MAX
N	950	1150
O	1150	1400
P	1400	1700

### ■ Dominant Wavelength [ $\lambda d$ ]

Rank Name	$\lambda d$ (nm)	
	MIN	MAX
A	582	586
B	586	594
C	594	598

### ■ Forward Voltage

Rank Name	Vf (V)	
	MIN	MAX
1	1.6	2.0
2	2.0	2.4
3	2.4	2.8

## 6.Soldering Profile

### (1) Reflow Soldering Conditions / Profile (Lead Free Solder)

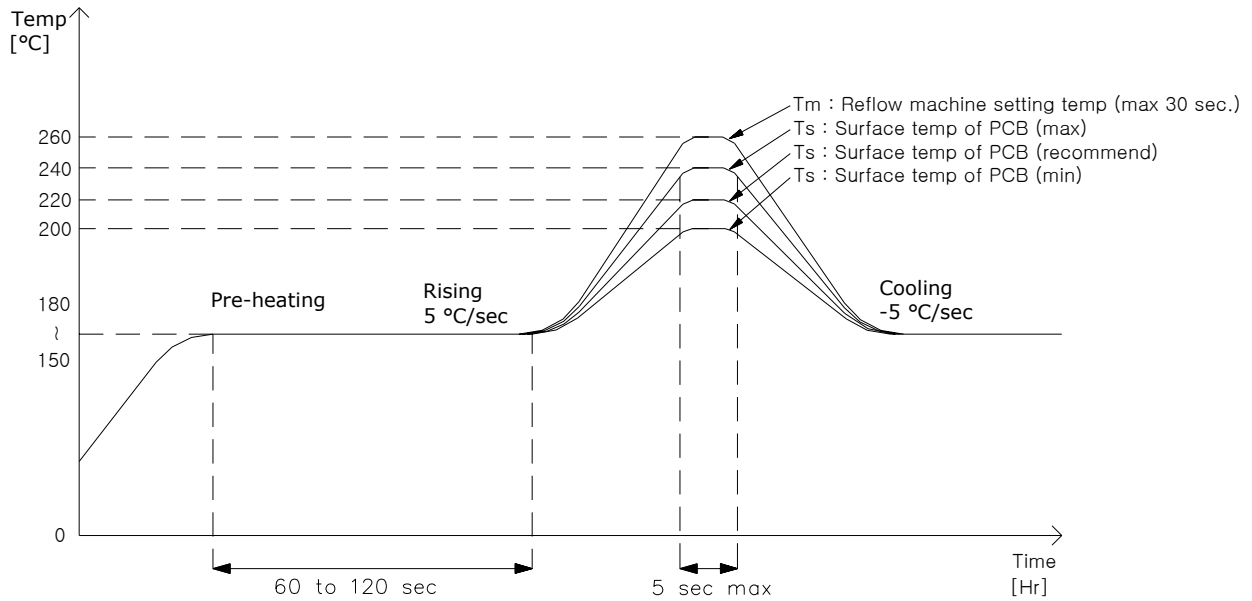

### (2) Hand Soldering conditions

Do not exceed 4 seconds at maximum 315°C under soldering iron.

Note : In case that the soldered products are reused in soldering process, we don't guarantee the products.

## 7. Outline Dimension And Material

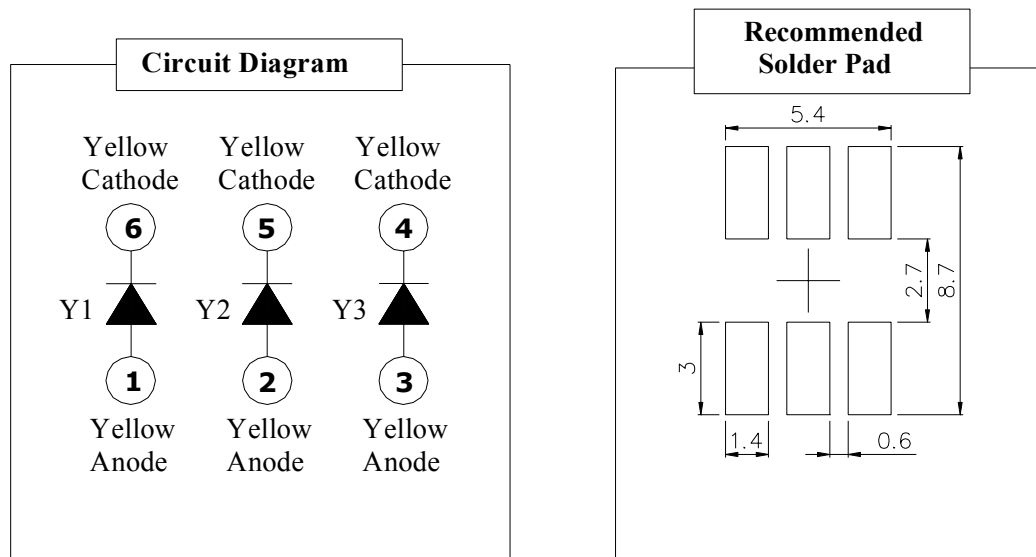
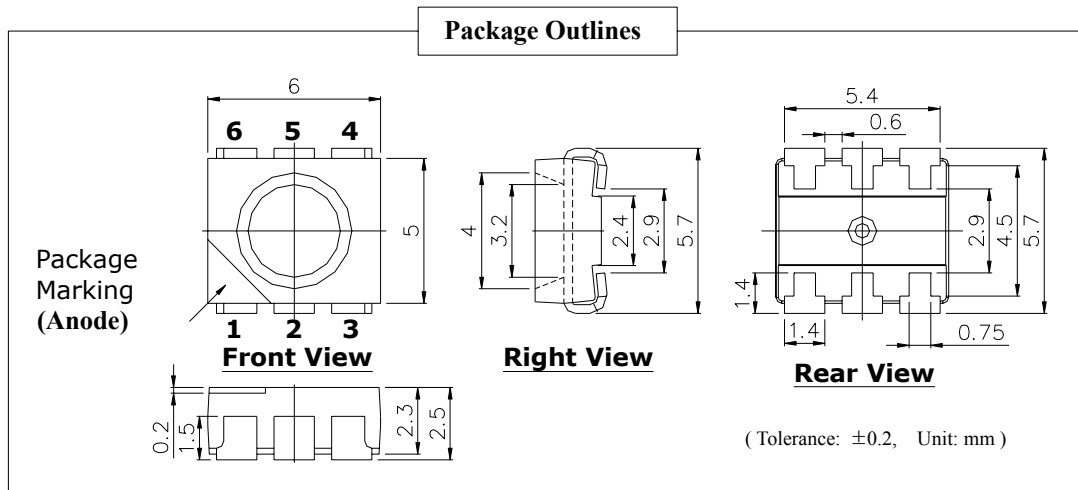

### \* MATERIALS

PARTS	MATERIALS
Package	Heat-Resistant Polymer
Encapsulating Resin	Epoxy Resin
Electrodes	Ag Plating Copper Alloy

## 8. Packing

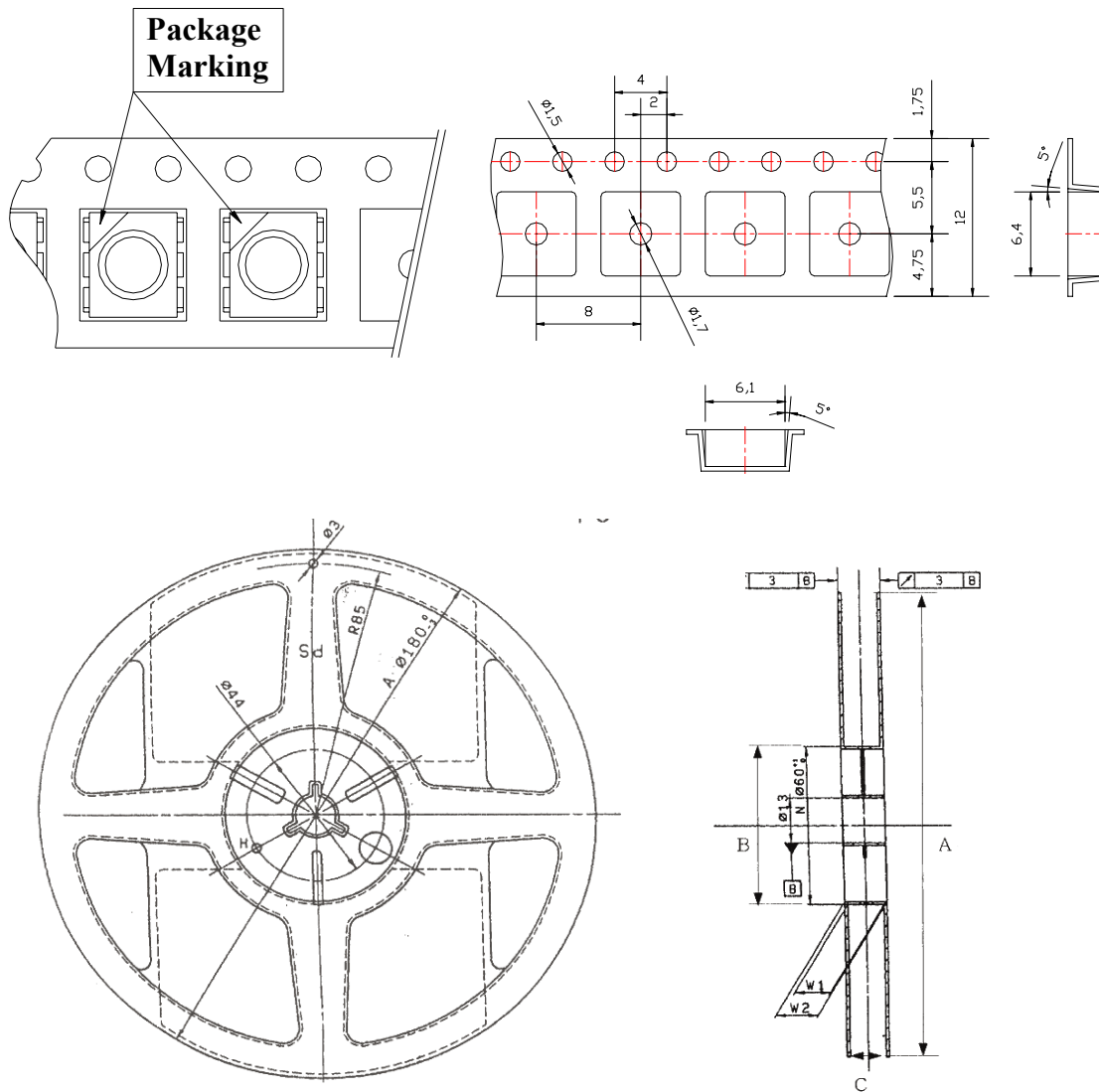

(Tolerance:  $\pm 0.2$ , Unit: mm)

- (1) Quantity : 700pcs/Reel
- (2) Cumulative Tolerance : Cumulative Tolerance/10 pitches to be  $\pm 0.2$ mm
- (3) Adhesion Strength of Cover Tape : Adhesion strength to be 0.1-0.7N when the cover tape is turned off from the carrier tape at the angle of  $10^\circ$  to the carrier tape
- (4) Package : P/N, Manufacturing data Code No. and quantity to be indicated on a damp proof Package

SSC-QP-7-03-08(REV.00)

SEOUL SEMICONDUCTOR CO., LTD.  
148-29 Kasan-Dong, Keumchun-Gu, Seoul, 153-023, Korea  
Phone : 82-2-2106-7305-6

SSC-HYT722

## 9. Reel Packing Structure

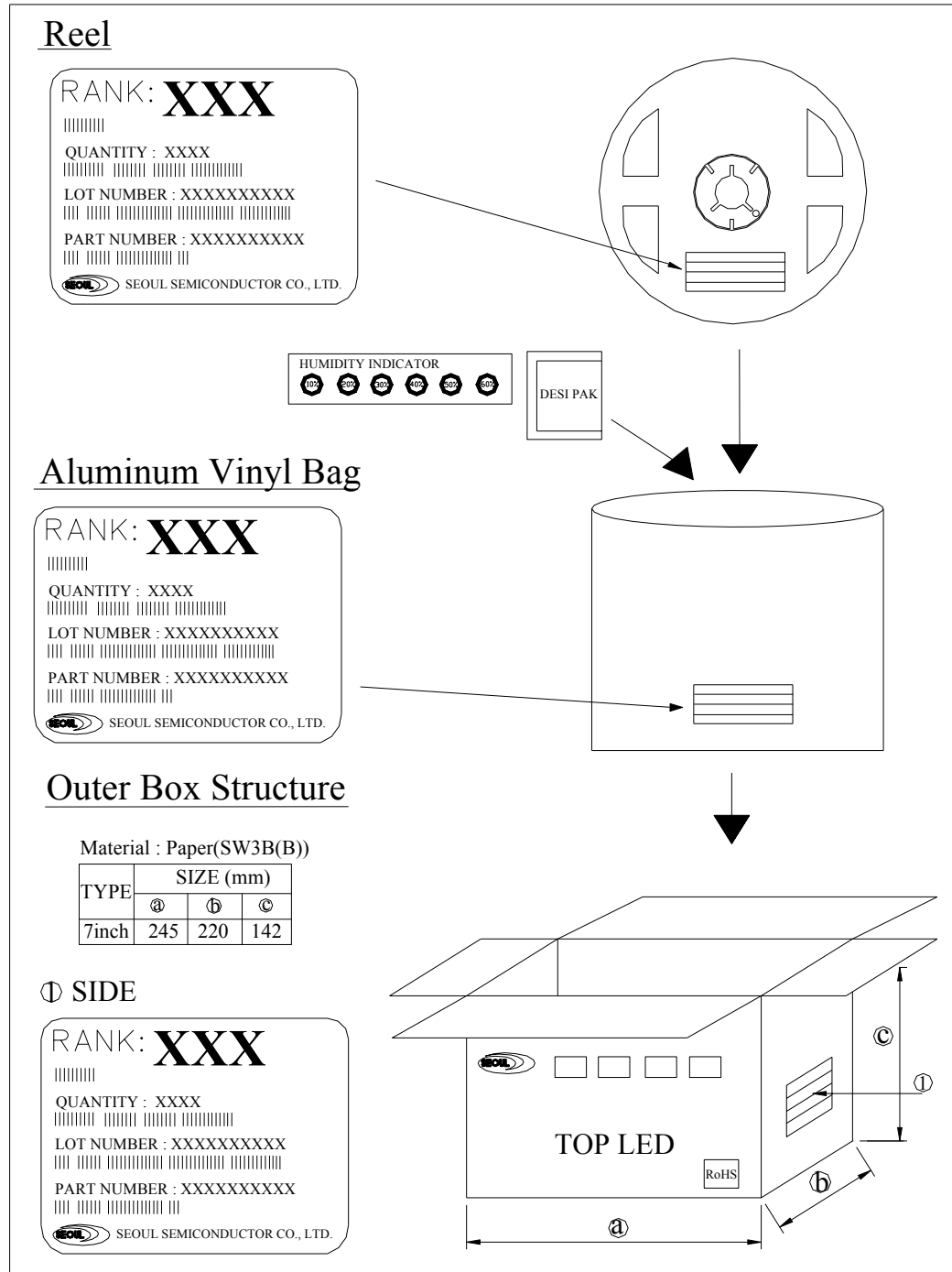



**10. Lot Number**

The lot number is composed of the following characters;

**HYT**○□□◎◎ #~#

**HYT** First Part Name

○ Year (6 for 2006, 7 for 2007, 8 for 2008 )

□□ Month ( 01 for Jan., 02 for Feb., ······11 for Nov., 12 for Dec.)

◎◎ Day ( 01, 02, 03, 04, ··········28, 29, 30, 31.)

#~# The number of the internal quality control

RANK: **XXX**

|||||

QUANTITY : 700

||||| ||||| ||||| |||||

LOT NUMBER : HYT70426 01 512

|||| ||||| ||||| ||||| ||||| |||||

PART NUMBER : HYT722

|||| ||||| ||||| |||||

 **SEOUL SEMICONDUCTOR CO., LTD.**

Downloaded from [Elcodis.com](http://Elcodis.com) electronic components distributor

## 11. Precaution for use

### (1) Storage

In order to avoid the absorption of moisture, it is recommended to store in a dry box (or a desiccator) with a desiccant. Otherwise, to store them in the following environment is recommended.

Temperature : 5°C ~30°C Humidity : maximum 70%RH

### (2) Attention after open.

LED is correspond to SMD, when LED be soldered dip, interfacial separation may affect the light transmission efficiency, causing the light intensity to drop. Attention in followed;

Keeping of a fraction

Temperature : 5 ~ 40°C Humidity : less than 10%

(3) In the case of more than 1 week passed after opening or change color of indicator on desiccant, components shall be dried 10-12hr. at 60±5°C.

(4) Any mechanical force or any excess vibration shall not be accepted to apply during cooling process to normal temperature after soldering.

(5) Quick cooling shall be avoided.

(6) Components shall not be mounted on warped direction of PCB.

(7) Anti radioactive ray design is not considered for the products.

(8) This device should not be used in any type of fluid such as water, oil, organic solvent etc. When washing is required, IPA should be used.

(9) When the LEDs are illuminating, operating current should be decided after considering the ambient maximum temperature.

(10) The LEDs must be soldered within seven days after opening the moisture-proof packing.

(11) Repack unused products with anti-moisture packing, fold to close any opening and then store in a dry place.

(12) The appearance and specifications of the product may be modified for improvement without notice.

## 12. Characteristic Diagram

Forward Current vs Forward Voltage  
(per die)

( $T_a=25^\circ\text{C}$ )

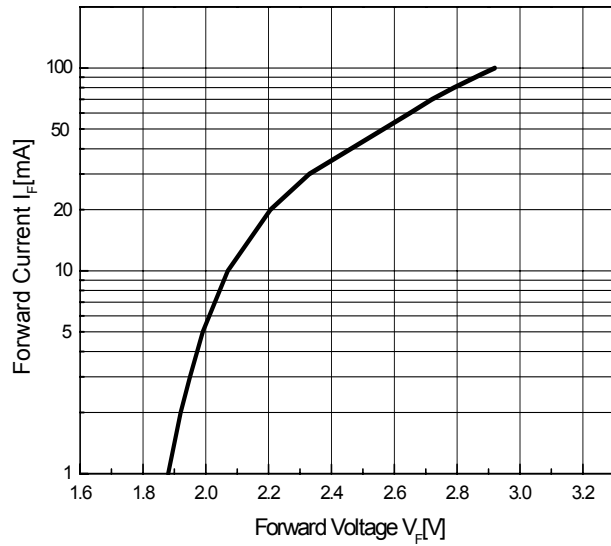

Relative Luminous Intensity vs Forward Current

(Total)

( $T_a=25^\circ\text{C}$ )

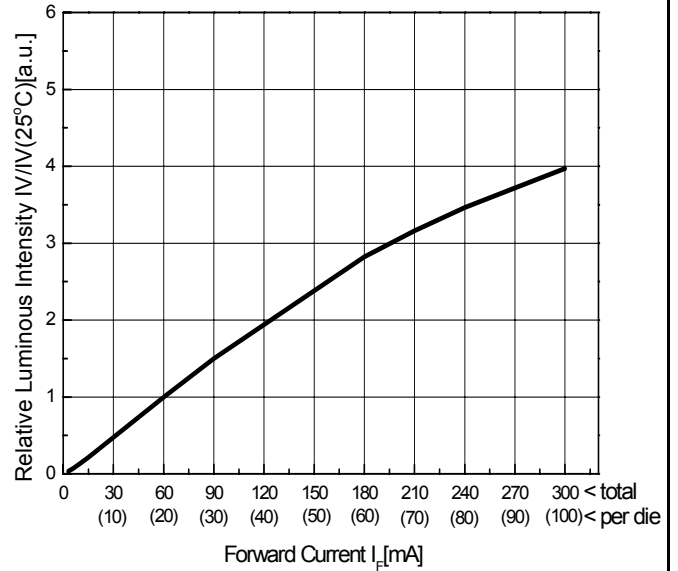

Forward Current Derating Curve

(per die)

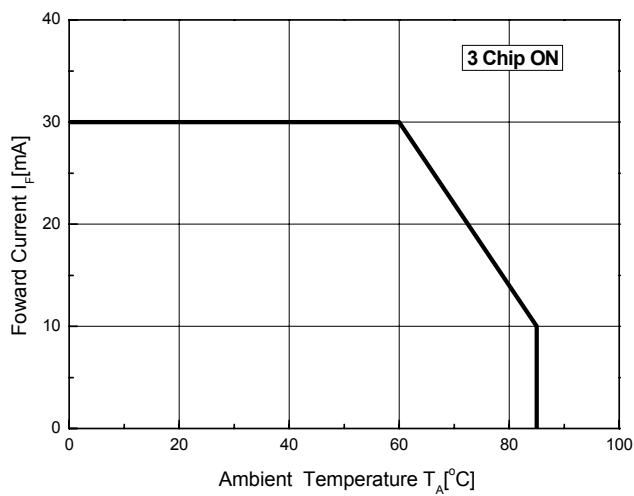

Radiation Diagram

( $T_a=25^\circ\text{C}$ )

