HM51W16165 Series

HM51W18165 Series

16 M EDO DRAM (1-Mword \times 16-bit)
4 k Refresh/1 k Refresh

ELPIDA

E0153H10 (Ver. 1.0)
(Previous ADE-203-650D (Z))
Jul. 6, 2001 (K)

Description

The HM51W16165 Series, HM51W18165 Series are CMOS dynamic RAMs organized as 1,048,576-word \times 16-bit. They employ the most advanced CMOS technology for high performance and low power. HM51W16165 Series, HM51W18165 Series offer Extended Data Out (EDO) Page Mode as a high speed access mode. They have package variations of standard 400-mil 42-pin plastic SOJ and 400-mil 50-pin plastic TSOP.

Features

- Single 3.3 V (± 0.3 V)
- Access time: 50 ns/60 ns/70 ns (max)
- Power dissipation
 - Active mode : 396 mW/360mW/324 mW (max) (HM51W16165 Series)
: 684 mW /612 mW /540 mW (max) (HM51W18165 Series)
 - Standby mode : 7.2 mW (max)
: 0.54 mW (max) (L-version)
- EDO page mode capability
- Refresh cycles
 - 4096 refresh cycles : 64 ms (HM51W16165 Series)
: 128 ms (L-version)
 - 1024 refresh cycles : 16 ms (HM51W18165 Series)
: 128 ms (L-version)
- 4 variations of refresh
 - $\overline{\text{RAS}}$ -only refresh
 - $\overline{\text{CAS}}$ -before- $\overline{\text{RAS}}$ refresh
 - Hidden refresh
 - Self refresh (L-version)
- 2CAS-byte control

Elpida Memory, Inc. is a joint venture DRAM company of NEC Corporation and Hitachi, Ltd.

HM51W16165 Series, HM51W18165 Series

- Battery backup operation (L-version)

Ordering Information

Type No.	Access time	Package
HM51W16165J-5	50 ns	400-mil 42-pin plastic SOJ (CP-42D)
HM51W16165J-6	60 ns	
HM51W16165J-7	70 ns	
HM51W16165LJ-5	50 ns	
HM51W16165LJ-6	60 ns	
HM51W16165LJ-7	70 ns	
HM51W18165J-5	50 ns	
HM51W18165J-6	60 ns	
HM51W18165J-7	70 ns	
HM51W18165LJ-5	50 ns	
HM51W18165LJ-6	60 ns	
HM51W18165LJ-7	70 ns	
HM51W16165TT-5	50 ns	400-mil 50-pin plastic TSOP II (TTP-50/44DC)
HM51W16165TT-6	60 ns	
HM51W16165TT-7	70 ns	
HM51W16165LTT-5	50 ns	
HM51W16165LTT-6	60 ns	
HM51W16165LTT-7	70 ns	
HM51W18165TT-5	50 ns	
HM51W18165TT-6	60 ns	
HM51W18165TT-7	70 ns	
HM51W18165LTT-5	50 ns	
HM51W18165LTT-6	60 ns	
HM51W18165LTT-7	70 ns	

HM51W16165 Series, HM51W18165 Series

Pin Arrangement

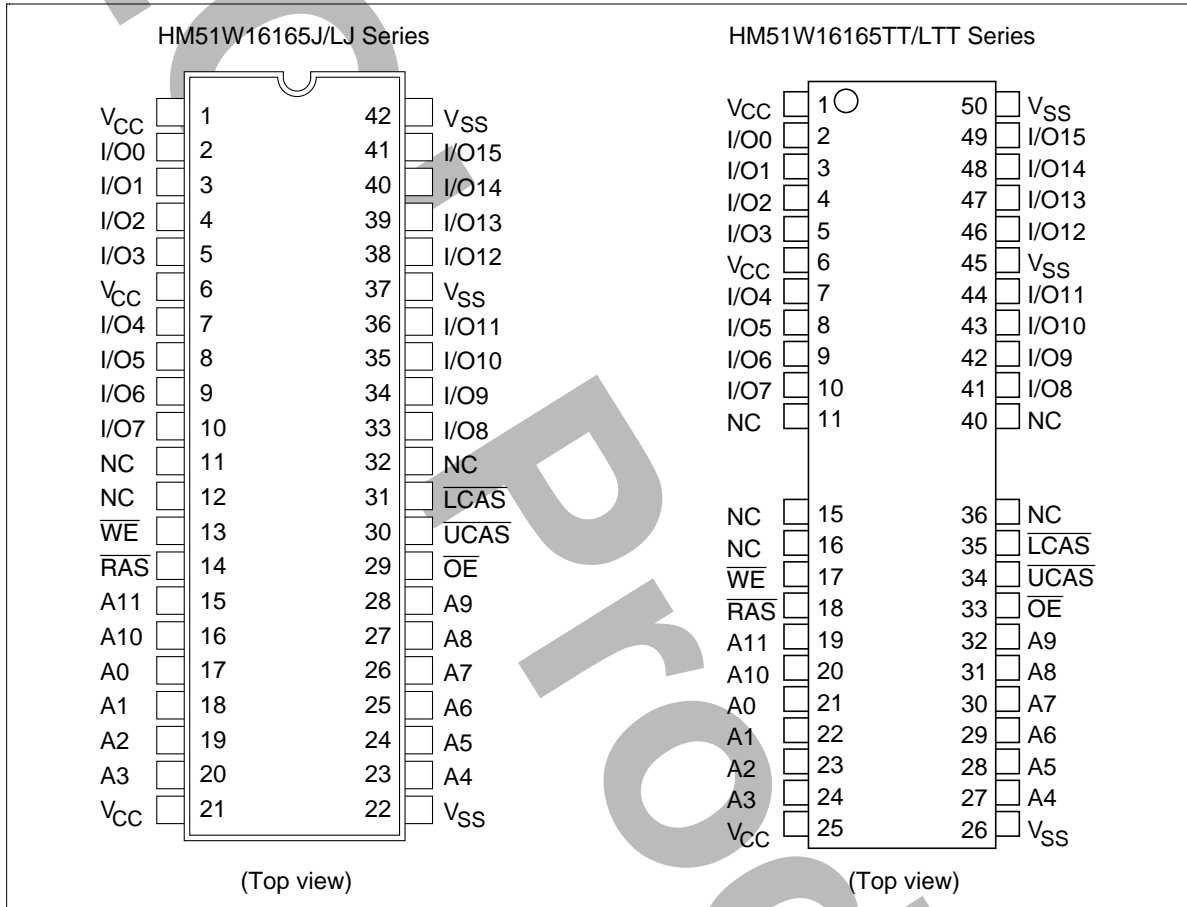

Pin Description

Pin name	Function
A0 to A11	Address input — Row/Refresh address A0 to A11 — Column address A0 to A7
I/O0 to I/O15	Data input/Data output
RAS	Row address strobe
UCAS, LCAS	Column address strobe
WE	Read/Write enable
OE	Output enable
V _{CC}	Power supply
V _{SS}	Ground
NC	No connection

HM51W16165 Series, HM51W18165 Series

Pin Arrangement

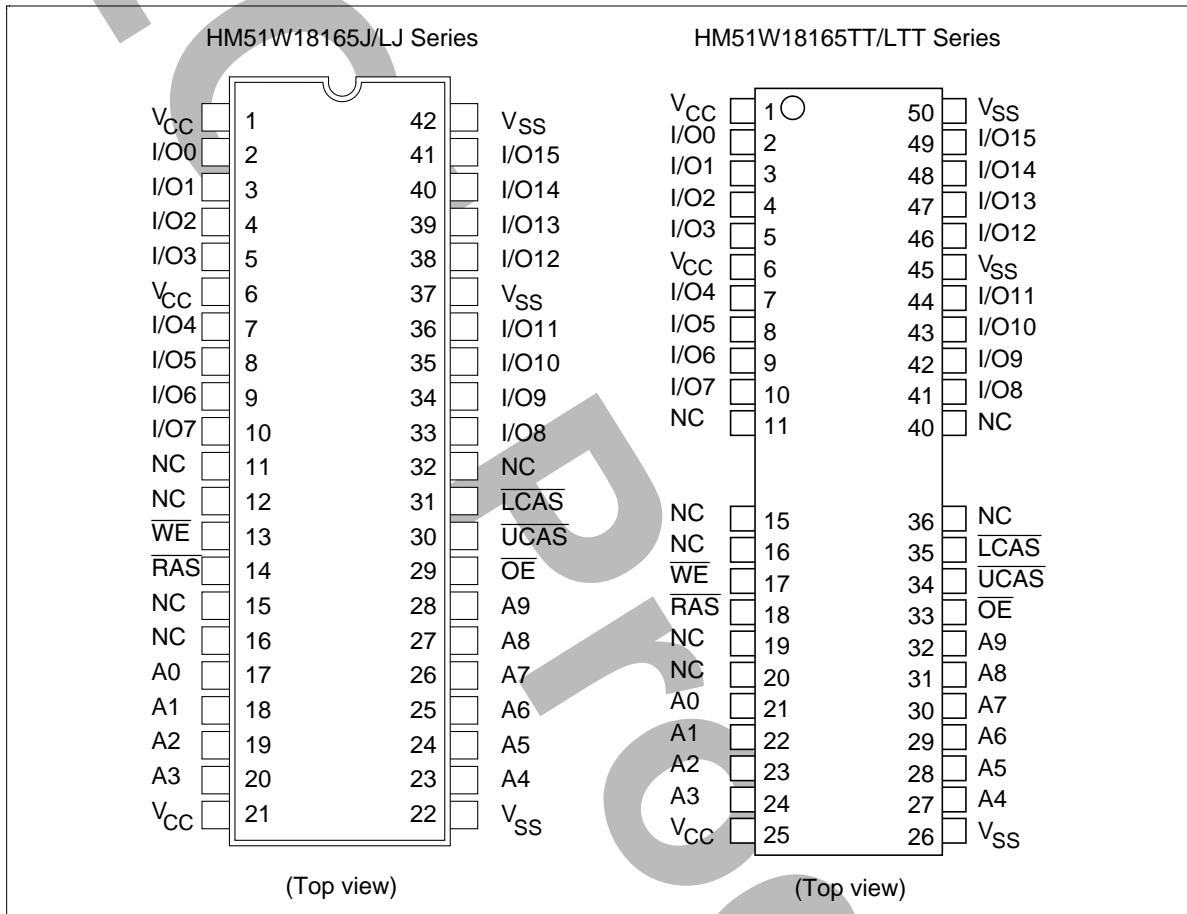

Pin Description

Pin name	Function
A0 to A9	Address input — Row/Refresh address A0 to A9 — Column address A0 to A9
I/O0 to I/O15	Data input/Data output
RAS	Row address strobe
UCAS, LCAS	Column address strobe
WE	Read/Write enable
OE	Output enable
V _{CC}	Power supply
V _{SS}	Ground
NC	No connection

HM51W16165 Series, HM51W18165 Series

Block Diagram (HM51W16165 Series)

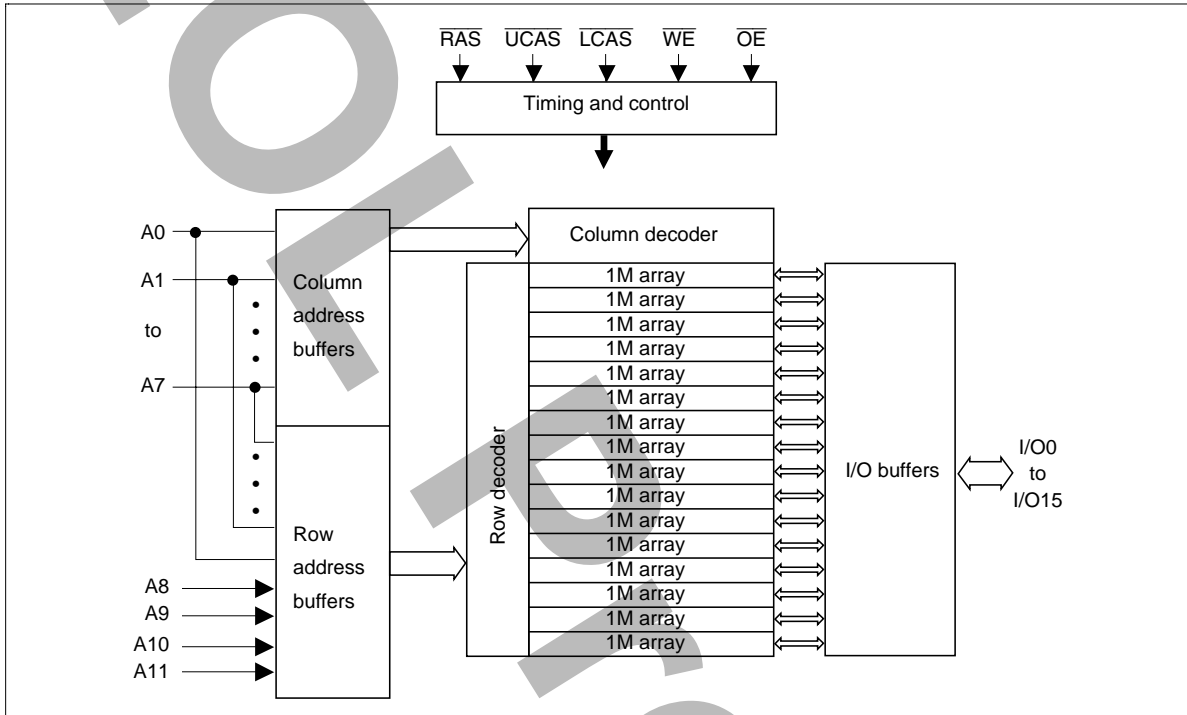

Block Diagram (HM51W18165 Series)

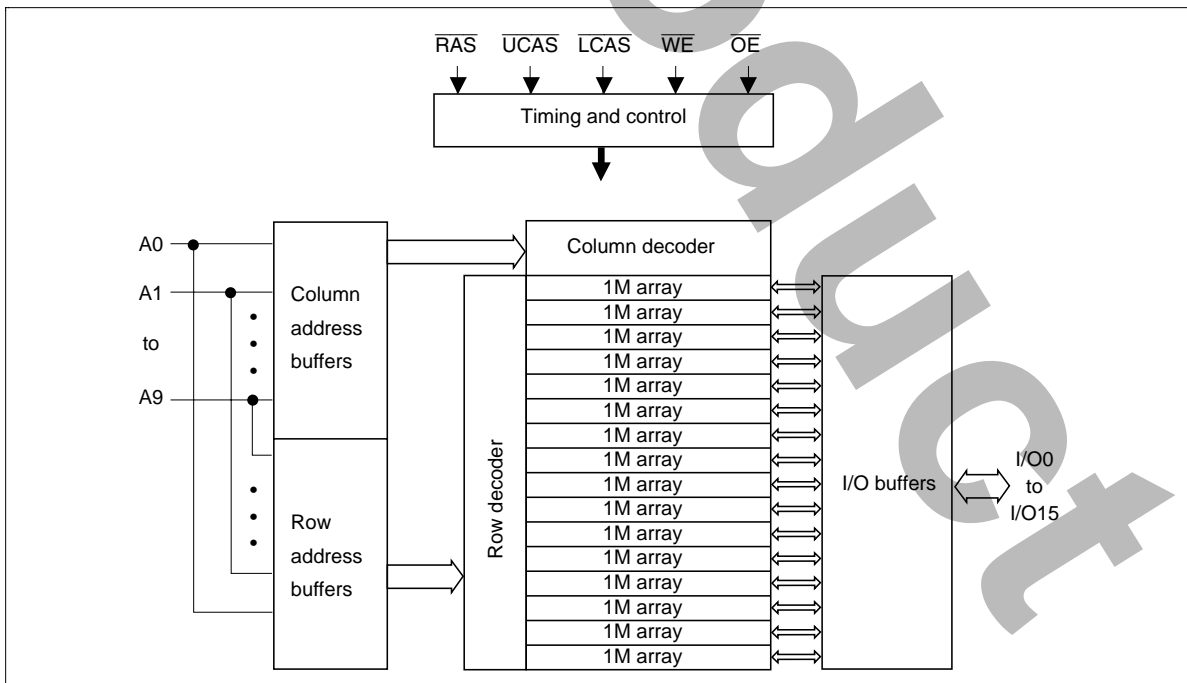

HM51W16165 Series, HM51W18165 Series

Truth Table

$\overline{\text{RAS}}$	$\overline{\text{LCAS}}$	$\overline{\text{UCAS}}$	$\overline{\text{WE}}$	$\overline{\text{OE}}$	Output		Operation
H	D	D	D	D	Open		Standby
L	L	H	H	L	Valid	Lower byte	Read cycle
L	H	L	H	L	Valid	Upper byte	
L	L	L	H	L	Valid	Word	
L	L	H	L* ²	D	Open	Lower byte	Early write cycle
L	H	L	L* ²	D	Open	Upper byte	
L	L	L	L* ²	D	Open	Word	
L	L	H	L* ²	H	Undefined	Lower byte	Delayed write cycle
L	H	L	L* ²	H	Undefined	Upper byte	
L	L	L	L* ²	H	Undefined	Word	
L	L	H	H to L	L to H	Valid	Lower byte	Read-modify-write cycle
L	H	L	H to L	L to H	Valid	Upper byte	
L	L	L	H to L	L to H	Valid	Word	
L	H	H	D	D	Open	Word	$\overline{\text{RAS}}$ -only refresh cycle
H to L	H	L	D	D	Open	Word	$\overline{\text{CAS}}$ -before- $\overline{\text{RAS}}$ refresh cycle or
H to L	L	H	D	D	Open	Word	Self refresh cycle (L-version)
H to L	L	L	D	D	Open	Word	
L	L	L	H	H	Open		Read cycle (Output disabled)

- Notes: 1. H: High (inactive) L: Low (active) D: H or L
2. $t_{\text{WCS}} \geq 0$ ns Early write cycle
 $t_{\text{WCS}} < 0$ ns Delayed write cycle
3. Mode is determined by the OR function of the $\overline{\text{UCAS}}$ and $\overline{\text{LCAS}}$. (Mode is set by the earliest of $\overline{\text{UCAS}}$ and $\overline{\text{LCAS}}$ active edge and reset by the latest of $\overline{\text{UCAS}}$ and $\overline{\text{LCAS}}$ inactive edge.)
 However write OPERATION and output HIZ control are done independently by each $\overline{\text{UCAS}}$, $\overline{\text{LCAS}}$.
 ex. if $\overline{\text{RAS}} = \text{H to L}$, $\overline{\text{UCAS}} = \text{H}$, $\overline{\text{LCAS}} = \text{L}$, then $\overline{\text{CAS}}$ -before- $\overline{\text{RAS}}$ refresh cycle is selected.

HM51W16165 Series, HM51W18165 Series

Absolute Maximum Ratings

Parameter	Symbol	Value	Unit
Voltage on any pin relative to V_{SS}	V_T	-0.5 to $V_{CC} + 0.5$ ($\leq +4.6$ V (max))	V
Supply voltage relative to V_{SS}	V_{CC}	-0.5 to +4.6	V
Short circuit output current	I_{out}	50	mA
Power dissipation	P_T	1.0	W
Operating temperature	T_{opr}	0 to +70	°C
Storage temperature	T_{stg}	-55 to +125	°C

Recommended DC Operating Conditions ($T_a = 0$ to +70°C)

Parameter	Symbol	Min	Typ	Max	Unit	Notes
Supply voltage	V_{CC}	3.0	3.3	3.6	V	1, 2
Input high voltage	V_{IH}	2.0	—	$V_{CC} + 0.3$	V	1
Input low voltage	V_{IL}	-0.3	—	0.8	V	1

Notes: 1. All voltage referred to V_{SS} .

2. The supply voltage with all V_{CC} pins must be on the same level. The supply voltage with all V_{SS} pins must be on the same level.

HM51W16165 Series, HM51W18165 Series

DC Characteristics

($T_a = 0$ to $+70^\circ\text{C}$, $V_{CC} = 3.3 \text{ V} \pm 0.3 \text{ V}$, $V_{SS} = 0 \text{ V}$) (HM51W16165 Series)

Parameter	Symbol	HM51W16165						Unit	Test conditions
		-5		-6		-7			
		Min	Max	Min	Max	Min	Max		
Operating current ^{*1, *2}	I_{CC1}	—	110	—	100	—	90	mA	$t_{RC} = \text{min}$
Standby current	I_{CC2}	—	2	—	2	—	2	mA	TTL interface $\overline{\text{RAS}}, \overline{\text{UCAS}}, \overline{\text{LCAS}} = V_{IH}$ Dout = High-Z
		—	1	—	1	—	1	mA	CMOS interface RAS, UCAS, $\text{LCAS} \geq V_{CC} - 0.2 \text{ V}$ Dout = High-Z
Standby current (L-version)	I_{CC2}	—	150	—	150	—	150	μA	CMOS interface RAS, UCAS, $\text{LCAS} \geq V_{CC} - 0.2 \text{ V}$ Dout = High-Z
RAS-only refresh current ^{*2}	I_{CC3}	—	110	—	100	—	90	mA	$t_{RC} = \text{min}$
Standby current ^{*1}	I_{CC5}	—	5	—	5	—	5	mA	$\overline{\text{RAS}} = V_{IH}$ $\overline{\text{UCAS}}, \overline{\text{LCAS}} = V_{IL}$ Dout = enable
CAS-before-RAS refresh current	I_{CC6}	—	110	—	100	—	90	mA	$t_{RC} = \text{min}$
EDO page mode current ^{*1, *3}	I_{CC7}	—	105	—	95	—	85	mA	$t_{HPC} = \text{min}$
Battery backup current ^{*4} (Standby with CBR refresh) (L-version)	I_{CC10}	—	400	—	400	—	400	μA	CMOS interface Dout = High-Z CBR refresh: $t_{RC} = 31.3 \mu\text{s}$ $t_{RAS} \leq 0.3 \mu\text{s}$
Self refresh mode current (L-version)	I_{CC11}	—	250	—	250	—	250	μA	CMOS interface RAS, UCAS, $\text{LCAS} \leq 0.2 \text{ V}$ Dout = High-Z
Input leakage current	I_{LI}	-10	10	-10	10	-10	10	μA	$0 \text{ V} \leq V_{in} \leq 4.6 \text{ V}$
Output leakage current	I_{LO}	-10	10	-10	10	-10	10	μA	$0 \text{ V} \leq V_{out} \leq 4.6 \text{ V}$ Dout = disable
Output high voltage	V_{OH}	2.4	V_{CC}	2.4	V_{CC}	2.4	V_{CC}	V	High Iout = -2 mA
Output low voltage	V_{OL}	0	0.4	0	0.4	0	0.4	V	Low Iout = 2 mA

- Notes:
- I_{CC} depends on output load condition when the device is selected. I_{CC} max is specified at the output open condition.
 - Address can be changed once or less while $\overline{\text{RAS}} = V_{IL}$.
 - Address can be changed once or less while $\overline{\text{UCAS}}$ and $\overline{\text{LCAS}} = V_{IH}$.
 - $V_{IH} \geq V_{CC} - 0.2 \text{ V}$, $0 \text{ V} \leq V_{IL} \leq 0.2 \text{ V}$.

HM51W16165 Series, HM51W18165 Series

DC Characteristics

($T_a = 0$ to $+70^\circ\text{C}$, $V_{CC} = 3.3 \text{ V} \pm 0.3 \text{ V}$, $V_{SS} = 0 \text{ V}$) (HM51W18165 Series)

Parameter	Symbol	HM51W18165						Unit	Test conditions
		-5		-6		-7			
		Min	Max	Min	Max	Min	Max		
Operating current ^{+*1, *2}	I_{CC1}	—	190	—	170	—	150	mA	$t_{RC} = \text{min}$
Standby current	I_{CC2}	—	2	—	2	—	2	mA	TTL interface $\overline{\text{RAS}}, \overline{\text{UCAS}}, \overline{\text{LCAS}} = V_{IH}$ Dout = High-Z
		—	1	—	1	—	1	mA	CMOS interface RAS, UCAS, $\text{LCAS} \geq V_{CC} - 0.2 \text{ V}$ Dout = High-Z
Standby current (L-version)	I_{CC2}	—	150	—	150	—	150	μA	CMOS interface RAS, UCAS, $\text{LCAS} \geq V_{CC} - 0.2 \text{ V}$ Dout = High-Z
$\overline{\text{RAS}}$ -only refresh current ^{+*2}	I_{CC3}	—	190	—	170	—	150	mA	$t_{RC} = \text{min}$
Standby current ^{*1}	I_{CC5}	—	5	—	5	—	5	mA	$\overline{\text{RAS}} = V_{IH}$ $\overline{\text{UCAS}}, \overline{\text{LCAS}} = V_{IL}$ Dout = enable
$\overline{\text{CAS}}$ -before- $\overline{\text{RAS}}$ refresh current	I_{CC6}	—	190	—	170	—	150	mA	$t_{RC} = \text{min}$
EDO page mode current ^{*1, *3}	I_{CC7}	—	185	—	165	—	145	mA	$t_{HPC} = \text{min}$
Battery backup current ^{*4} (Standby with CBR refresh) (L-version)	I_{CC10}	—	400	—	400	—	400	μA	CMOS interface Dout = High-Z CBR refresh: $t_{RC} = 125 \mu\text{s}$ $t_{RAS} \leq 0.3 \mu\text{s}$
Self refresh mode current (L-version)	I_{CC11}	—	250	—	250	—	250	μA	CMOS interface $\overline{\text{RAS}}, \overline{\text{UCAS}},$ $\overline{\text{LCAS}} \leq 0.2 \text{ V}$ Dout = High-Z
Input leakage current	I_{LI}	-10	10	-10	10	-10	10	μA	$0 \text{ V} \leq V_{in} \leq 4.6 \text{ V}$
Output leakage current	I_{LO}	-10	10	-10	10	-10	10	μA	$0 \text{ V} \leq V_{out} \leq 4.6 \text{ V}$ Dout = disable
Output high voltage	V_{OH}	2.4	V_{CC}	2.4	V_{CC}	2.4	V_{CC}	V	High Iout = -2 mA
Output low voltage	V_{OL}	0	0.4	0	0.4	0	0.4	V	Low Iout = 2 mA

Notes: 1. I_{CC} depends on output load condition when the device is selected. I_{CC} max is specified at the output open condition.

2. Address can be changed once or less while $\overline{\text{RAS}} = V_{IL}$.

3. Address can be changed once or less while $\overline{\text{UCAS}}$ and $\overline{\text{LCAS}} = V_{IH}$.

4. $V_{IH} \geq V_{CC} - 0.2 \text{ V}$, $0 \text{ V} \leq V_{IL} \leq 0.2 \text{ V}$.

HM51W16165 Series, HM51W18165 Series

Capacitance ($T_a = 25^\circ\text{C}$, $V_{CC} = 3.3\text{ V} \pm 0.3\text{ V}$)

Parameter	Symbol	Typ	Max	Unit	Notes
Input capacitance (Address)	C_{11}	—	5	pF	1
Input capacitance (Clocks)	C_{12}	—	7	pF	1
Output capacitance (Data-in, Data-out)	$C_{I/O}$	—	7	pF	1, 2

Notes : 1. Capacitance measured with Boonton Meter or effective capacitance measuring method.
2. $\overline{\text{RAS}}$, $\overline{\text{UCAS}}$ and $\overline{\text{LCAS}} = V_{IH}$ to disable Dout.

HM51W16165 Series, HM51W18165 Series

AC Characteristics ($T_a = 0$ to $+70^\circ\text{C}$, $V_{CC} = 3.3\text{ V} \pm 0.3\text{ V}$, $V_{SS} = 0\text{ V}$)^{*1, *2, *18, *19, *20}

Test Conditions

- Input rise and fall time: 2 ns
- Input levels: 0 V, 3.0 V
- Input timing reference levels: 0.8 V, 2.0 V
- Output timing reference levels: 0.8 V, 2.0 V
- Output load: 1 TTL gate + C_L (100 pF) (Including scope and jig)

Read, Write, Read-Modify-Write and Refresh Cycles (Common parameters)

		HM51W16165/HM51W18165							
		-5		-6		-7			
Parameter	Symbol	Min	Max	Min	Max	Min	Max	Unit	Notes
Random read or write cycle time	t_{RC}	84	—	104	—	124	—	ns	
$\overline{\text{RAS}}$ precharge time	t_{RP}	30	—	40	—	50	—	ns	
$\overline{\text{CAS}}$ precharge time	t_{CP}	8	—	10	—	13	—	ns	
$\overline{\text{RAS}}$ pulse width	t_{RAS}	50	10000	60	10000	70	10000	ns	
$\overline{\text{CAS}}$ pulse width	t_{CAS}	8	10000	10	10000	13	10000	ns	
Row address setup time	t_{ASR}	0	—	0	—	0	—	ns	
Row address hold time	t_{RAH}	8	—	10	—	10	—	ns	
Column address setup time	t_{ASC}	0	—	0	—	0	—	ns	21
Column address hold time	t_{CAH}	8	—	10	—	13	—	ns	21
$\overline{\text{RAS}}$ to $\overline{\text{CAS}}$ delay time	t_{RCD}	12	37	14	45	14	52	ns	3
$\overline{\text{RAS}}$ to column address delay time	t_{RAD}	10	25	12	30	12	35	ns	4
$\overline{\text{RAS}}$ hold time	t_{RSH}	10	—	13	—	13	—	ns	
$\overline{\text{CAS}}$ hold time	t_{CSH}	35	—	40	—	45	—	ns	23
$\overline{\text{CAS}}$ to $\overline{\text{RAS}}$ precharge time	t_{CRP}	5	—	5	—	5	—	ns	22
$\overline{\text{OE}}$ to Din delay time	t_{OED}	13	—	15	—	18	—	ns	5
$\overline{\text{OE}}$ delay time from Din	t_{DZO}	0	—	0	—	0	—	ns	6
$\overline{\text{CAS}}$ delay time from Din	t_{DZC}	0	—	0	—	0	—	ns	6
Transition time (rise and fall)	t_T	2	50	2	50	2	50	ns	7

HM51W16165 Series, HM51W18165 Series

Read Cycle

Parameter	Symbol	HM51W16165/HM51W18165						Unit	Notes
		-5		-6		-7			
		Min	Max	Min	Max	Min	Max		
Access time from $\overline{\text{RAS}}$	t_{RAC}	—	50	—	60	—	70	ns	8, 9
Access time from $\overline{\text{CAS}}$	t_{CAC}	—	13	—	15	—	18	ns	9, 10, 17
Access time from address	t_{AA}	—	25	—	30	—	35	ns	9, 11, 17
Access time from $\overline{\text{OE}}$	t_{OEA}	—	13	—	15	—	18	ns	9
Read command setup time	t_{RCS}	0	—	0	—	0	—	ns	21
Read command hold time to $\overline{\text{CAS}}$	t_{RCH}	0	—	0	—	0	—	ns	12, 22
Read command hold time from $\overline{\text{RAS}}$	t_{RCHR}	50	—	60	—	70	—	ns	
Read command hold time to $\overline{\text{RAS}}$	t_{RRH}	0	—	0	—	0	—	ns	12
Column address to $\overline{\text{RAS}}$ lead time	t_{RAL}	25	—	30	—	35	—	ns	
Column address to $\overline{\text{CAS}}$ lead time	t_{CAL}	15	—	18	—	23	—	ns	
$\overline{\text{CAS}}$ to output in low-Z	t_{CLZ}	0	—	0	—	0	—	ns	
Output data hold time	t_{OH}	3	—	3	—	3	—	ns	27
Output data hold time from $\overline{\text{OE}}$	t_{OHO}	3	—	3	—	3	—	ns	
Output buffer turn-off time	t_{OFF}	—	13	—	15	—	15	ns	13, 27
Output buffer turn-off to $\overline{\text{OE}}$	t_{OEZ}	—	13	—	15	—	15	ns	13
$\overline{\text{CAS}}$ to Din delay time	t_{CDD}	13	—	15	—	18	—	ns	5
Output data hold time from $\overline{\text{RAS}}$	t_{OHR}	3	—	3	—	3	—	ns	27
Output buffer turn-off to $\overline{\text{RAS}}$	t_{OFR}	—	13	—	15	—	15	ns	27
Output buffer turn-off to $\overline{\text{WE}}$	t_{WEZ}	—	13	—	15	—	15	ns	
$\overline{\text{WE}}$ to Din delay time	t_{WED}	13	—	15	—	18	—	ns	
$\overline{\text{RAS}}$ to Din delay time	t_{RDD}	13	—	15	—	18	—	ns	
$\overline{\text{RAS}}$ next $\overline{\text{CAS}}$ delay time	t_{RNCD}	50	—	60	—	70	—	ns	

HM51W16165 Series, HM51W18165 Series

Write Cycle

		HM51W16165/HM51W18165							
		-5		-6		-7			
Parameter	Symbol	Min	Max	Min	Max	Min	Max	Unit	Notes
Write command setup time	t_{WCS}	0	—	0	—	0	—	ns	14, 21
Write command hold time	t_{WCH}	8	—	10	—	13	—	ns	21
Write command pulse width	t_{WP}	8	—	10	—	10	—	ns	
Write command to \overline{RAS} lead time	t_{RWL}	8	—	10	—	13	—	ns	
Write command to \overline{CAS} lead time	t_{CWL}	8	—	10	—	13	—	ns	23
Data-in setup time	t_{DS}	0	—	0	—	0	—	ns	15, 23
Data-in hold time	t_{DH}	8	—	10	—	13	—	ns	15, 23

Read-Modify-Write Cycle

		HM51W16165/HM51W18165							
		-5		-6		-7			
Parameter	Symbol	Min	Max	Min	Max	Min	Max	Unit	Notes
Read-modify-write cycle time	t_{RWC}	111	—	135	—	161	—	ns	
\overline{RAS} to \overline{WE} delay time	t_{RWD}	67	—	79	—	92	—	ns	14
\overline{CAS} to \overline{WE} delay time	t_{CWD}	30	—	34	—	40	—	ns	14
Column address to \overline{WE} delay time	t_{AWD}	42	—	49	—	57	—	ns	14
\overline{OE} hold time from \overline{WE}	t_{OEH}	13	—	15	—	18	—	ns	

Refresh Cycle

		HM51W16165/HM51W18165							
		-5		-6		-7			
Parameter	Symbol	Min	Max	Min	Max	Min	Max	Unit	Notes
\overline{CAS} setup time (CBR refresh cycle)	t_{CSR}	5	—	5	—	5	—	ns	21
\overline{CAS} hold time (CBR refresh cycle)	t_{CHR}	8	—	10	—	10	—	ns	22
\overline{RAS} precharge to \overline{CAS} hold time	t_{RPC}	5	—	5	—	5	—	ns	21

HM51W16165 Series, HM51W18165 Series

EDO Page Mode Cycle

Parameter	Symbol	HM51W16165/HM51W18165						Unit	Notes
		-5		-6		-7			
		Min	Max	Min	Max	Min	Max		
EDO page mode cycle time	t_{HPC}	20	—	25	—	30	—	ns	25
EDO page mode RAS pulse width	t_{RASP}	—	100000	—	100000	—	100000	ns	16
Access time from \overline{CAS} precharge	t_{CPA}	—	30	—	35	—	40	ns	9, 17, 22
\overline{RAS} hold time from \overline{CAS} precharge	t_{CPRH}	30	—	35	—	40	—	ns	
Output data hold time from \overline{CAS} low	t_{DOH}	3	—	3	—	3	—	ns	9
\overline{CAS} hold time referred OE	t_{COL}	8	—	10	—	13	—	ns	
\overline{CAS} to \overline{OE} setup time	t_{COP}	5	—	5	—	5	—	ns	
Read command hold time from \overline{CAS} precharge	t_{RCHC}	30	—	35	—	40	—	ns	

EDO Page Mode Read-Modify-Write Cycle

Parameter	Symbol	HM51W16165/HM51W18165						Unit	Notes
		-5		-6		-7			
		Min	Max	Min	Max	Min	Max		
EDO page mode read-modify-write cycle time	t_{HPRWC}	57	—	68	—	79	—	ns	
\overline{WE} delay time from \overline{CAS} precharge	t_{CPW}	45	—	54	—	62	—	ns	14, 22

Refresh (HM51W16165 Series)

Parameter	Symbol	Max	Unit	Note
Refresh period	t_{REF}	64	ms	4096 cycles
Refresh period (L-version)	t_{REF}	128	ms	4096 cycles

Refresh (HM51W18165 Series)

Parameter	Symbol	Max	Unit	Note
Refresh period	t_{REF}	16	ms	1024 cycles
Refresh period (L-version)	t_{REF}	128	ms	1024 cycles

HM51W16165 Series, HM51W18165 Series

Self Refresh Mode (L-version)

Parameter	Symbol	HM51W16165L/HM51W18165L						Unit	Notes
		-5		-6		-7			
		Min	Max	Min	Max	Min	Max		
RAS pulse width (self refresh)	t_{RASS}	100	—	100	—	100	—	μ s	28, 29, 30, 31
RAS precharge time (self refresh)	t_{RPS}	90	—	110	—	130	—	ns	
CAS hold time (self refresh)	t_{CHS}	-50	—	-50	—	-50	—	ns	

- Notes:
- AC measurements assume $t_r = 2$ ns.
 - An initial pause of 200 μ s is required after power up followed by a minimum of eight initialization cycles (any combination of cycles containing \overline{RAS} -only refresh or \overline{CAS} -before- \overline{RAS} refresh).
 - Operation with the t_{RCD} (max) limit insures that t_{RAC} (max) can be met, t_{RCD} (max) is specified as a reference point only; if $t_{RCD} \geq t_{RAD}(\text{max}) + t_{AA}(\text{max}) - t_{CAC}(\text{max})$, then access time is controlled exclusively by t_{CAC} .
 - Operation with the t_{RAD} (max) limit insures that t_{RAC} (max) can be met, t_{RAD} (max) is specified as a reference point only; if t_{RAD} is greater than the specified t_{RAD} (max) limit, then access time is controlled exclusively by t_{AA} .
 - Either t_{OED} or t_{CDD} must be satisfied.
 - Either t_{DZO} or t_{DZC} must be satisfied.
 - V_{IH} (min) and V_{IL} (max) are reference levels for measuring timing of input signals. Also, transition times are measured between V_{IH} (min) and V_{IL} (max).
 - Assumes that $t_{RCD} \leq t_{RCD}(\text{max})$ and $t_{RAD} \leq t_{RAD}(\text{max})$. If t_{RCD} or t_{RAD} is greater than the maximum recommended value shown in this table, t_{RAC} exceeds the value shown.
 - Measured with a load circuit equivalent to 1 TTL loads and 100 pF.
 - Assumes that $t_{RCD} \geq t_{RCD}(\text{max})$ and $t_{RCD} + t_{CAC}(\text{max}) \geq t_{RAD} + t_{AA}(\text{max})$.
 - Assumes that $t_{RAD} \geq t_{RAD}(\text{max})$ and $t_{RCD} + t_{CAC}(\text{max}) \leq t_{RAD} + t_{AA}(\text{max})$.
 - Either t_{RCH} or t_{RRH} must be satisfied for a read cycles.
 - $t_{OFF}(\text{max})$ and $t_{OEZ}(\text{max})$ define the time at which the outputs achieve the open circuit condition and are not referred to output voltage levels.
 - t_{WCS} , t_{RWD} , t_{CWD} , t_{AWD} and t_{CPW} are not restrictive operating parameters. They are included in the data sheet as electrical characteristics only; if $t_{WCS} \geq t_{WCS}(\text{min})$, the cycle is an early write cycle and the data out pin will remain open circuit (high impedance) throughout the entire cycle; if $t_{RWD} \geq t_{RWD}(\text{min})$, $t_{CWD} \geq t_{CWD}(\text{min})$, and $t_{AWD} \geq t_{AWD}(\text{min})$, or $t_{CWD} \geq t_{CWD}(\text{min})$, $t_{AWD} \geq t_{AWD}(\text{min})$ and $t_{CPW} \geq t_{CPW}(\text{min})$, the cycle is a read-modify-write and the data output will contain data read from the selected cell; if neither of the above sets of conditions is satisfied, the condition of the data out (at access time) is indeterminate.
 - These parameters are referred to \overline{UCAS} and \overline{LCAS} leading edge in early write cycles and to \overline{WE} leading edge in delayed write or read-modify-write cycles.
 - t_{RASP} defines \overline{RAS} pulse width in EDO page mode cycles.
 - Access time is determined by the longest among t_{AA} , t_{CAC} and t_{CPA} .
 - In delayed write or read-modify-write cycles, \overline{OE} must disable output buffer prior to applying data to the device
 - When both \overline{UCAS} and \overline{LCAS} go low at the same time, all 16-bit data are written into the device. \overline{UCAS} and \overline{LCAS} cannot be staggered within the same write/read cycles.
 - All the V_{CC} and V_{SS} pins shall be supplied with the same voltages.

HM51W16165 Series, HM51W18165 Series

21. t_{ASC} , t_{CAH} , t_{RCS} , t_{WCS} , t_{WCH} , t_{CSR} and t_{RPC} are determined by the earlier falling edge of \overline{UCAS} or \overline{LCAS} .
22. t_{CRP} , t_{CHR} , t_{RCH} , t_{CPA} and t_{CPW} are determined by the later rising edge of \overline{UCAS} or \overline{LCAS} .
23. t_{CWL} , t_{DH} , t_{DS} and t_{CHS} should be satisfied by both \overline{UCAS} and \overline{LCAS} .
24. t_{CP} is determined by the time that both \overline{UCAS} and \overline{LCAS} are high.
25. t_{HPC} (min) can be achieved during a series of EDO page mode write cycles or EDO page mode read cycles. If both write and read operation are mixed in a EDO page mode RAS cycle (EDO page mode mix cycle (1), (2)), minimum value of \overline{CAS} cycle ($t_{CAS} + t_{CP} + 2t_r$) becomes greater than the specified t_{HPC} (min) value. The value of \overline{CAS} cycle time of mixed EDO page mode is shown in EDO page mode mix cycle (1) and (2).
26. When output buffers are enabled once, sustain the low impedance state until valid data is obtained. When output buffer is turned on and off within a very short time, generally it causes large V_{CC}/V_{SS} line noise, which causes to degrade $V_{IH\ min}/V_{IL\ max}$ level.
27. Data output turns off and becomes high impedance from later rising edge of \overline{RAS} and \overline{CAS} . Hold time and turn off time are specified by the timing specifications of later rising edge of \overline{RAS} and \overline{CAS} between t_{OHR} and t_{OH} , and between t_{OFR} and t_{OFF} .
28. Please do not use t_{RASS} timing, $10\ \mu s \leq t_{RASS} \leq 100\ \mu s$. During this period, the device is in transition state from normal operation mode to self refresh mode. If $t_{RASS} \geq 100\ \mu s$, then RAS precharge time should use t_{RPS} instead of t_{RP} .
29. If you use distributed CBR refresh mode with $15.6\ \mu s$ interval in normal read/write cycle, CBR refresh should be executed within $15.6\ \mu s$ immediately after exiting from and before entering into self refresh mode.
30. If you use \overline{RAS} only refresh or CBR burst refresh mode in normal read/write cycle, 4096 or 1024 cycles (4096 cycles: HM51W16165 Series, 1024 cycles: HM51W18165 Series) of distributed CBR refresh with $15.6\ \mu s$ interval should be executed within 64 or 16 ms (64 ms: HM51W16165, 16 ms: HM51W18165) immediately after exiting from and before entering into the self refresh mode.
31. Repetitive self refresh mode without refreshing all memory is not allowed. Once you exit from self refresh mode, all memory cells need to be refreshed before re-entering the self refresh mode again.
32. XXX: H or L (H: $V_{IH\ (min)} \leq V_{IN} \leq V_{IH\ (max)}$, L: $V_{IL\ (min)} \leq V_{IN} \leq V_{IL\ (max)}$)
/////: Invalid Dout
When the address, clock and input pins are not described on timing waveforms, their pins must be applied V_{IH} or V_{IL} .

HM51W16165 Series, HM51W18165 Series

Notes concerning $\overline{2CAS}$ control

Please do not separate the $\overline{UCAS}/\overline{LCAS}$ operation timing intentionally. However skew between $\overline{UCAS}/\overline{LCAS}$ are allowed under the following conditions.

1. Each of the $\overline{UCAS}/\overline{LCAS}$ should satisfy the timing specifications individually.
2. Different operation mode for upper/lower byte is not allowed; such as following.

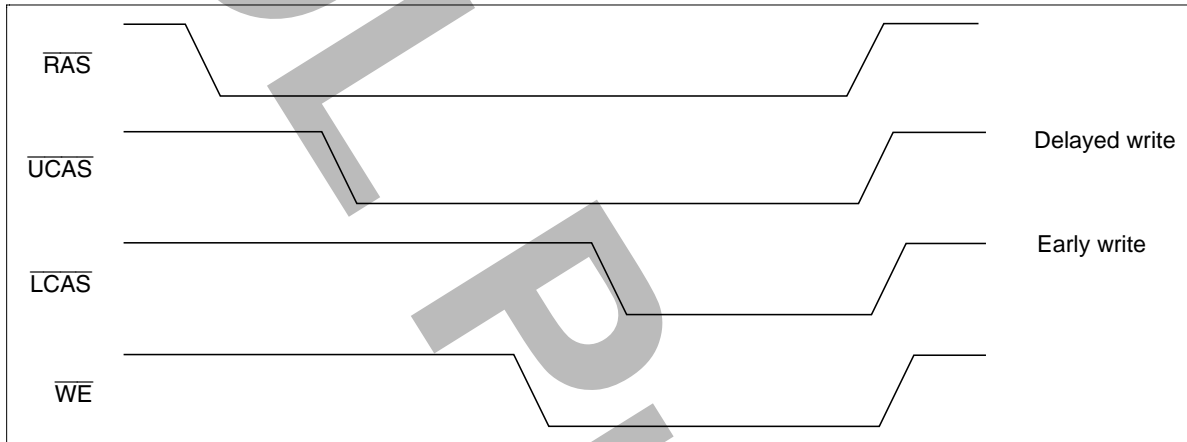

3. Closely separated upper/lower byte control is not allowed. However when the condition ($t_{CP} \leq t_{UL}$) is satisfied, EDO page mode can be performed.

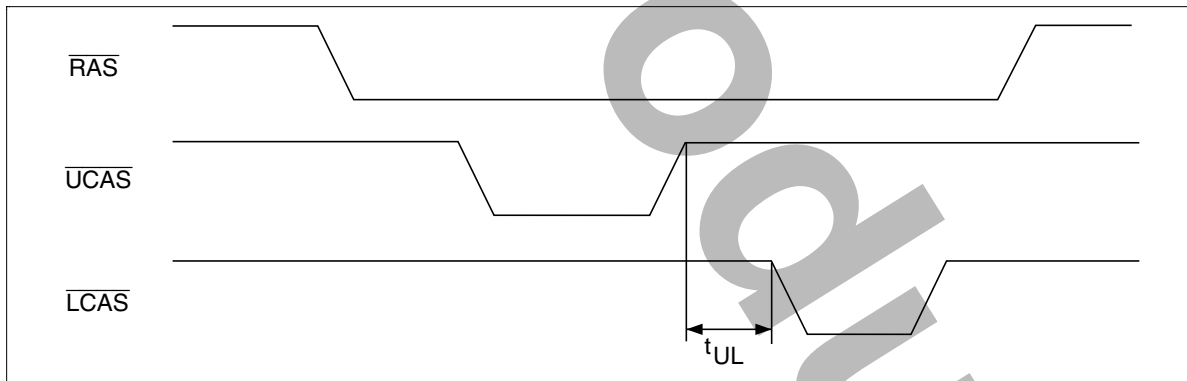

4. Byte control operation by remaining \overline{UCAS} or \overline{LCAS} high is guaranteed.

HM51W16165 Series, HM51W18165 Series

Timing Waveforms*32

Read Cycle

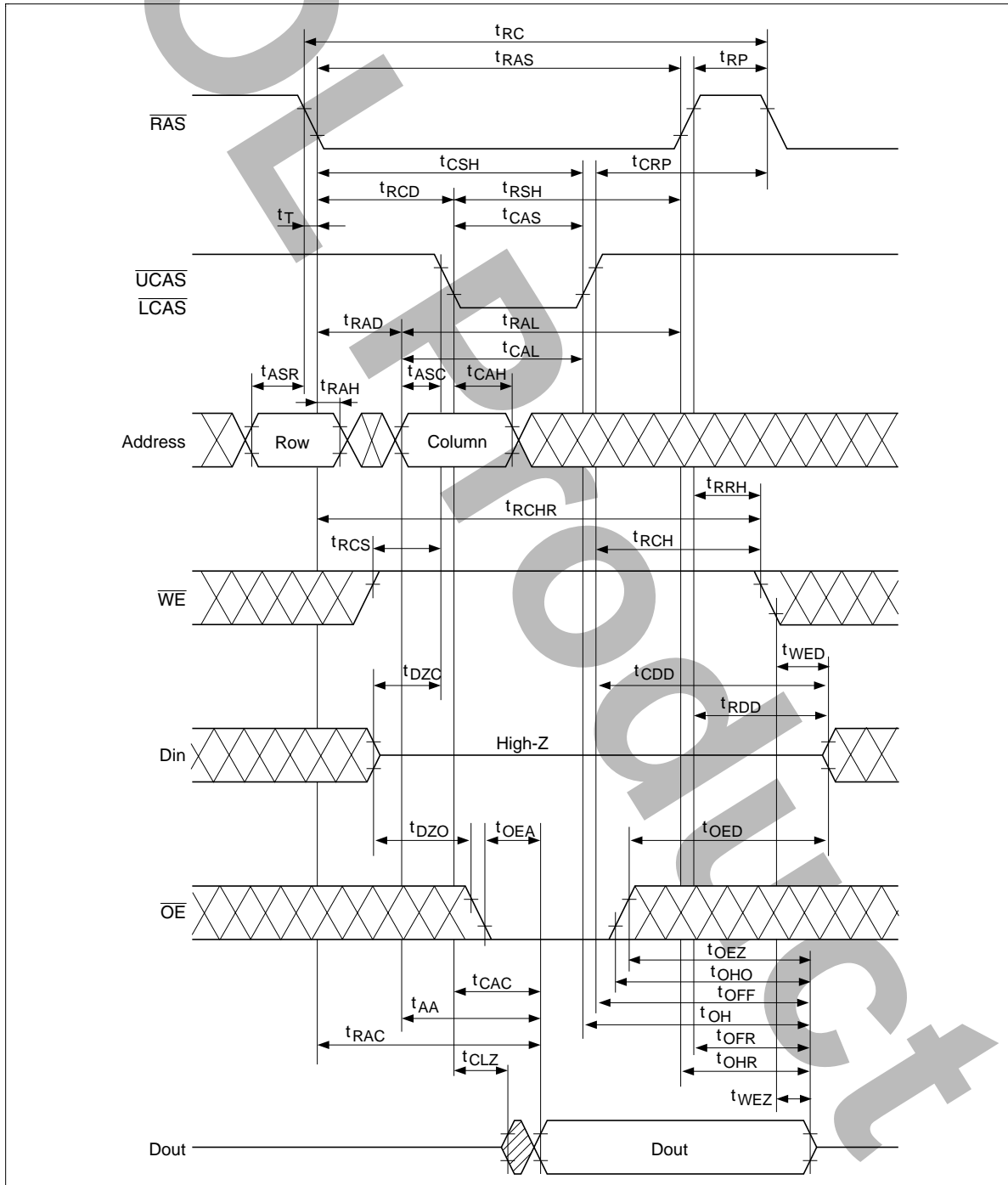

HM51W16165 Series, HM51W18165 Series

Early Write Cycle

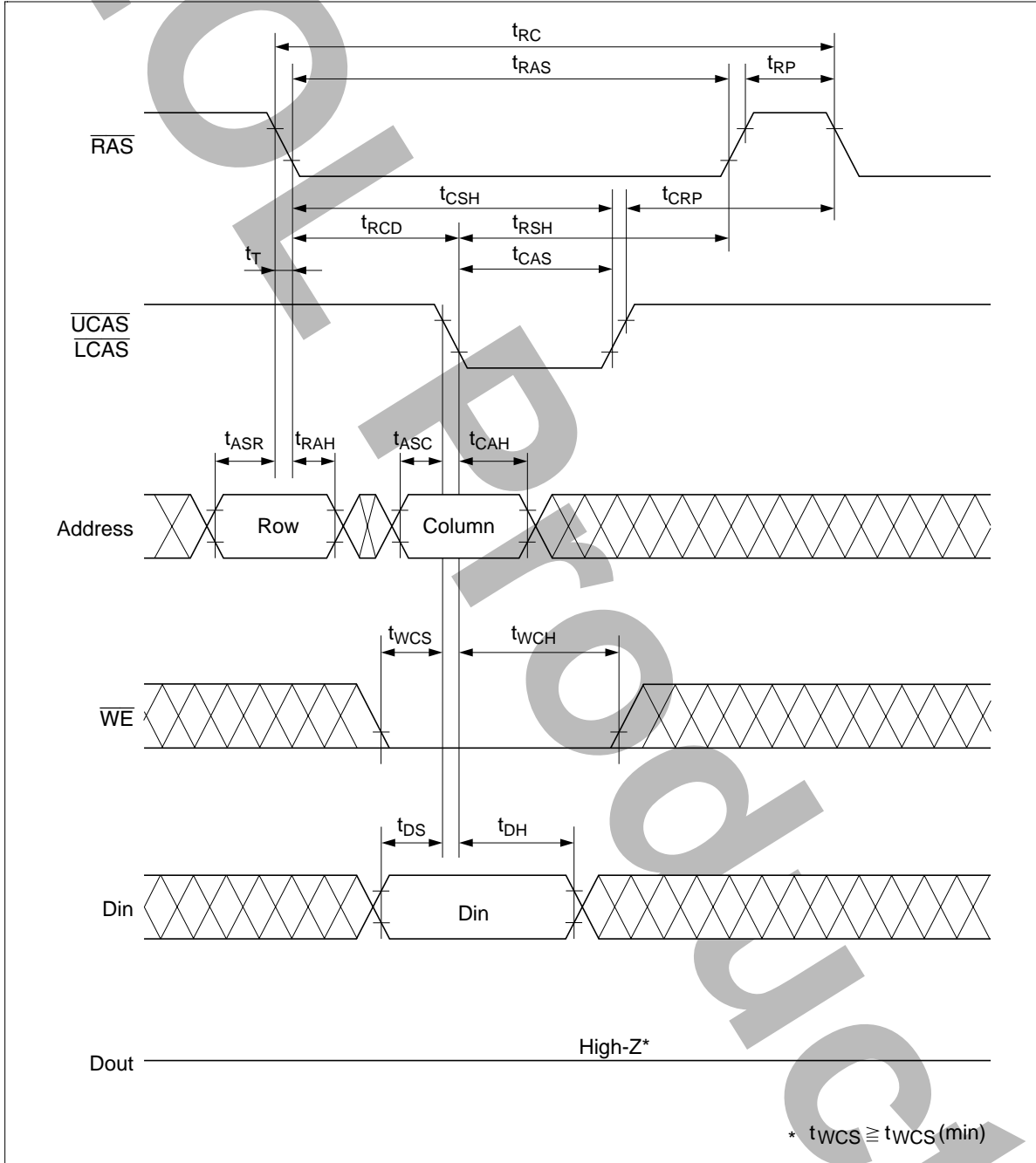

HM51W16165 Series, HM51W18165 Series

Delayed Write Cycle^{*18}

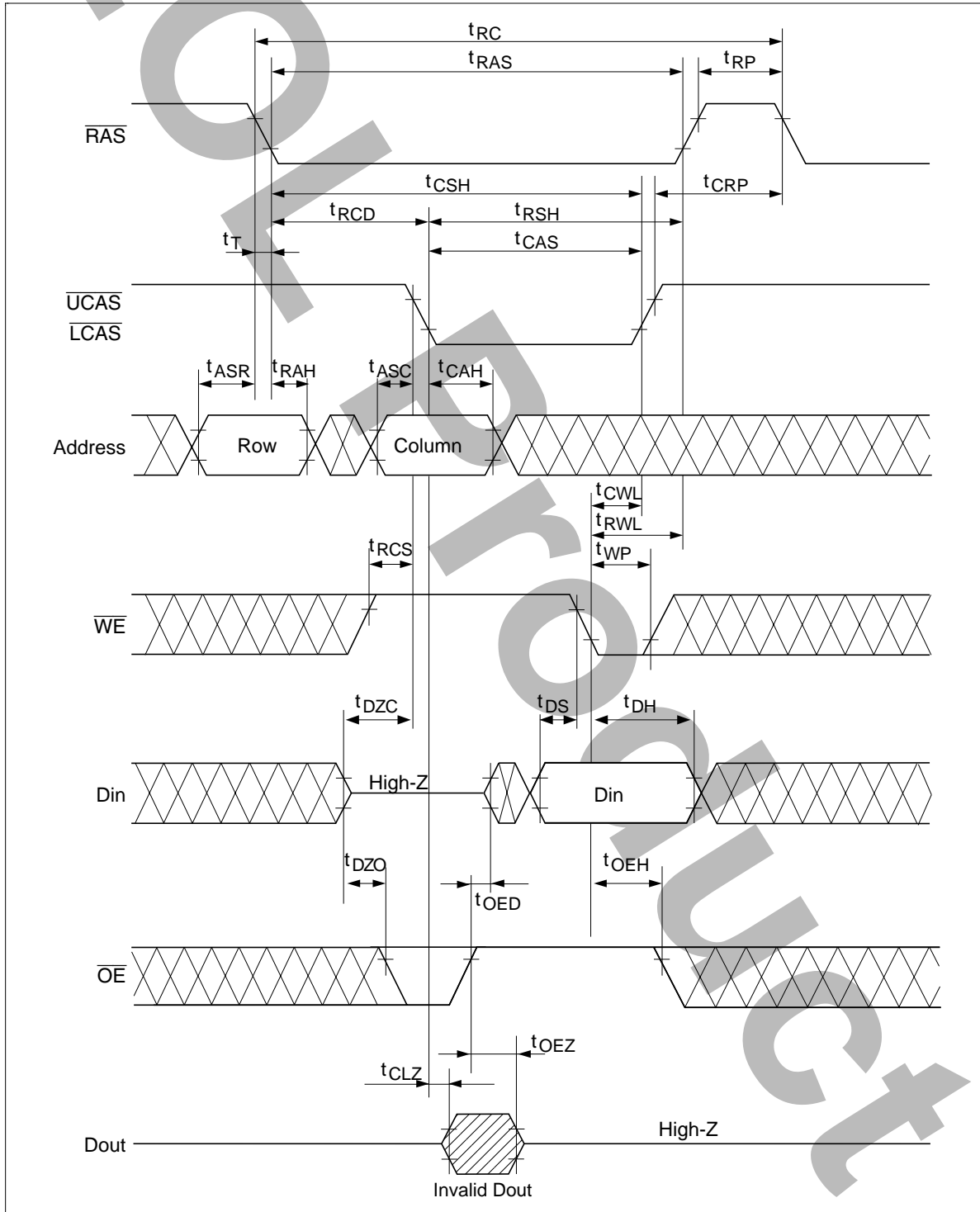

HM51W16165 Series, HM51W18165 Series

Read-Modify-Write Cycle*18

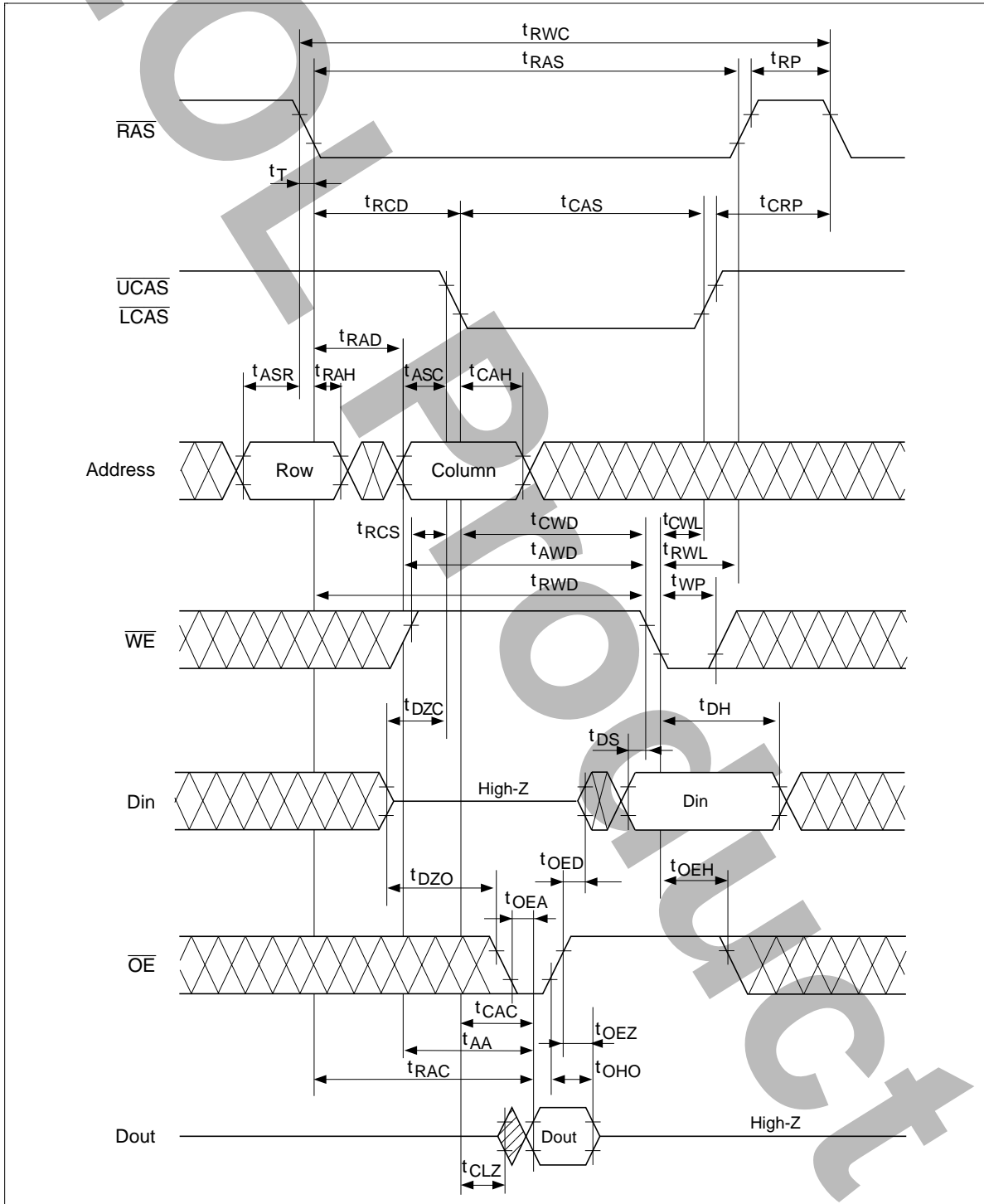

HM51W16165 Series, HM51W18165 Series

$\overline{\text{RAS}}$ -Only Refresh Cycle

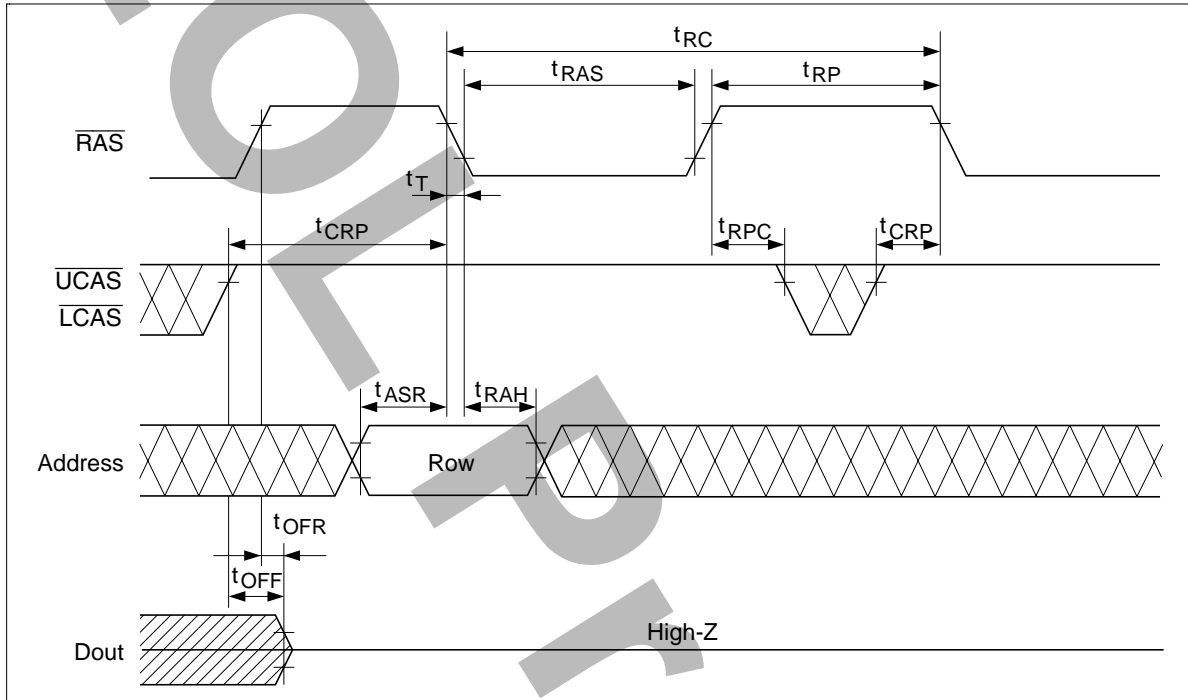

HM51W16165 Series, HM51W18165 Series

CAS-Before-RAS Refresh Cycle

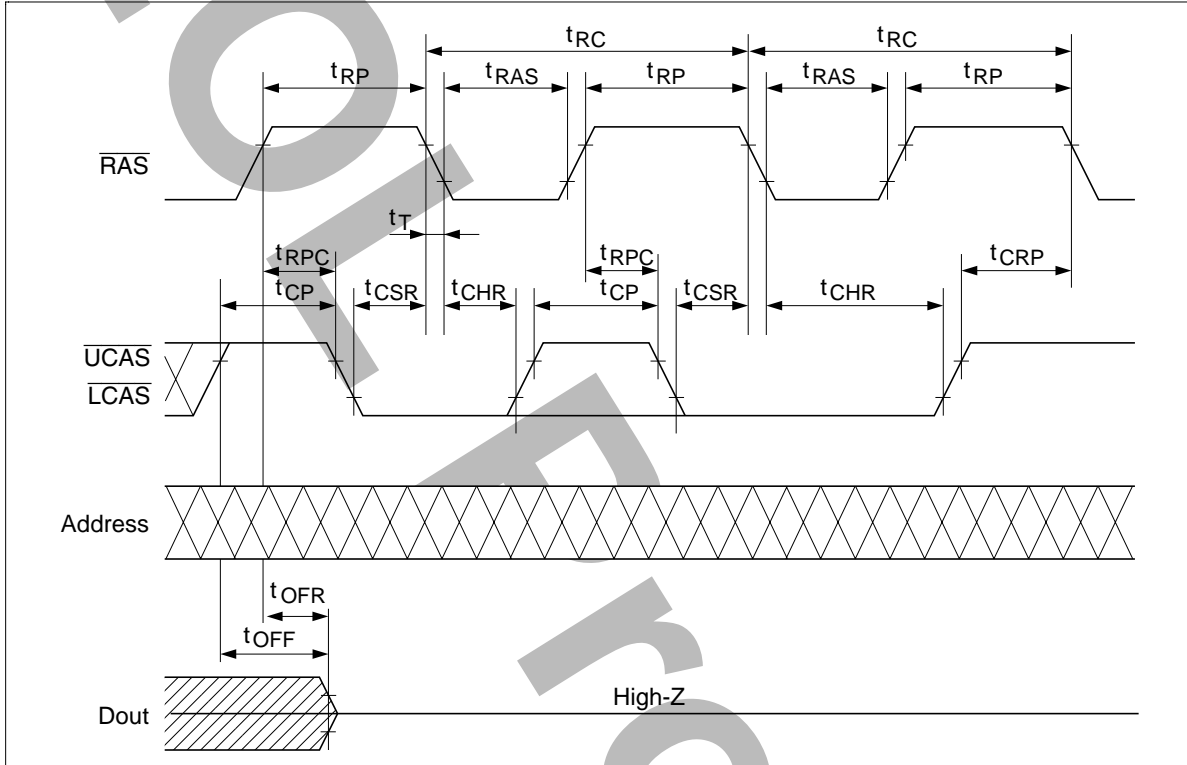

HM51W16165 Series, HM51W18165 Series

Hidden Refresh Cycle

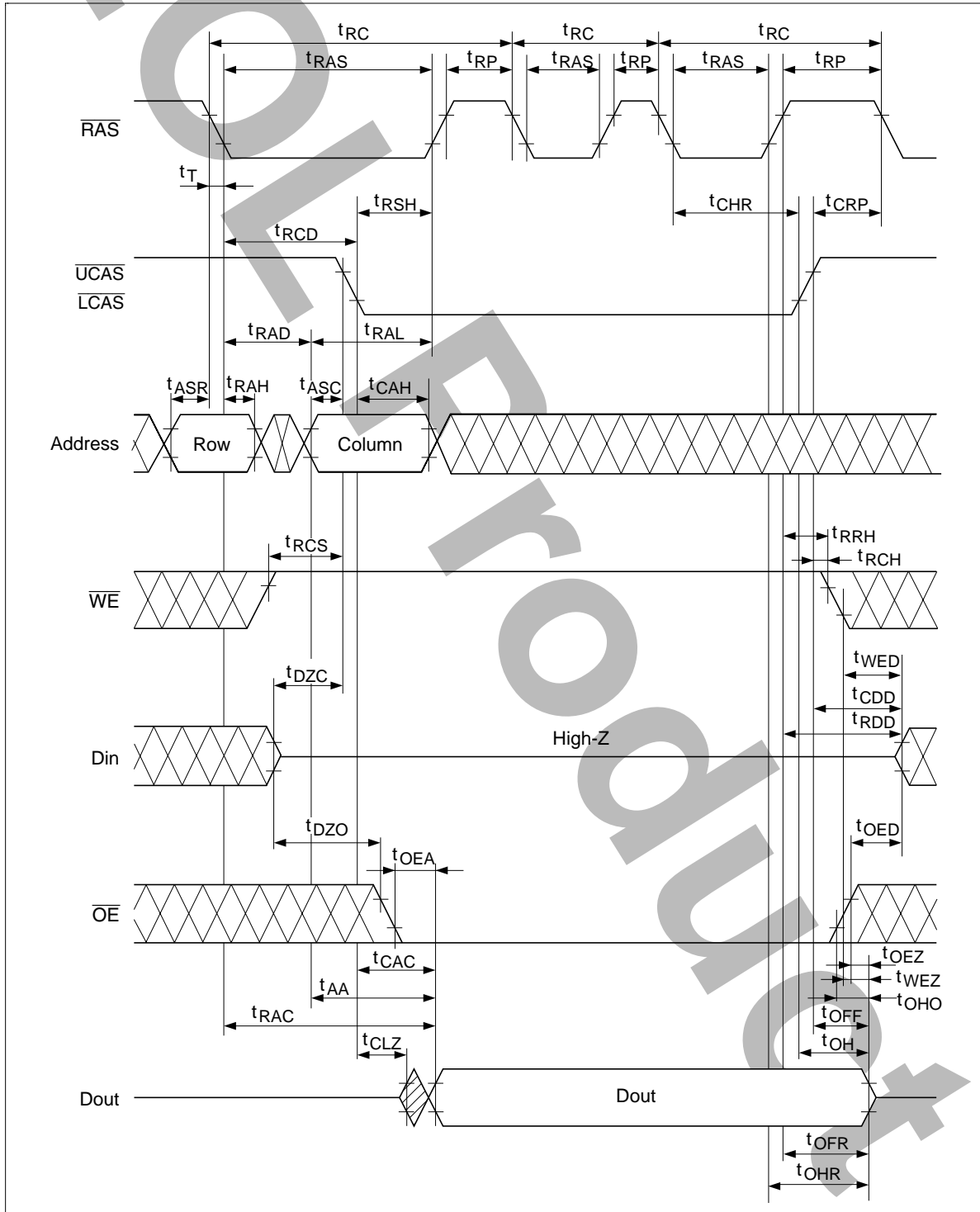

HM51W16165 Series, HM51W18165 Series

EDO Page Mode Read Cycle ($\overline{2CAS}$ control)

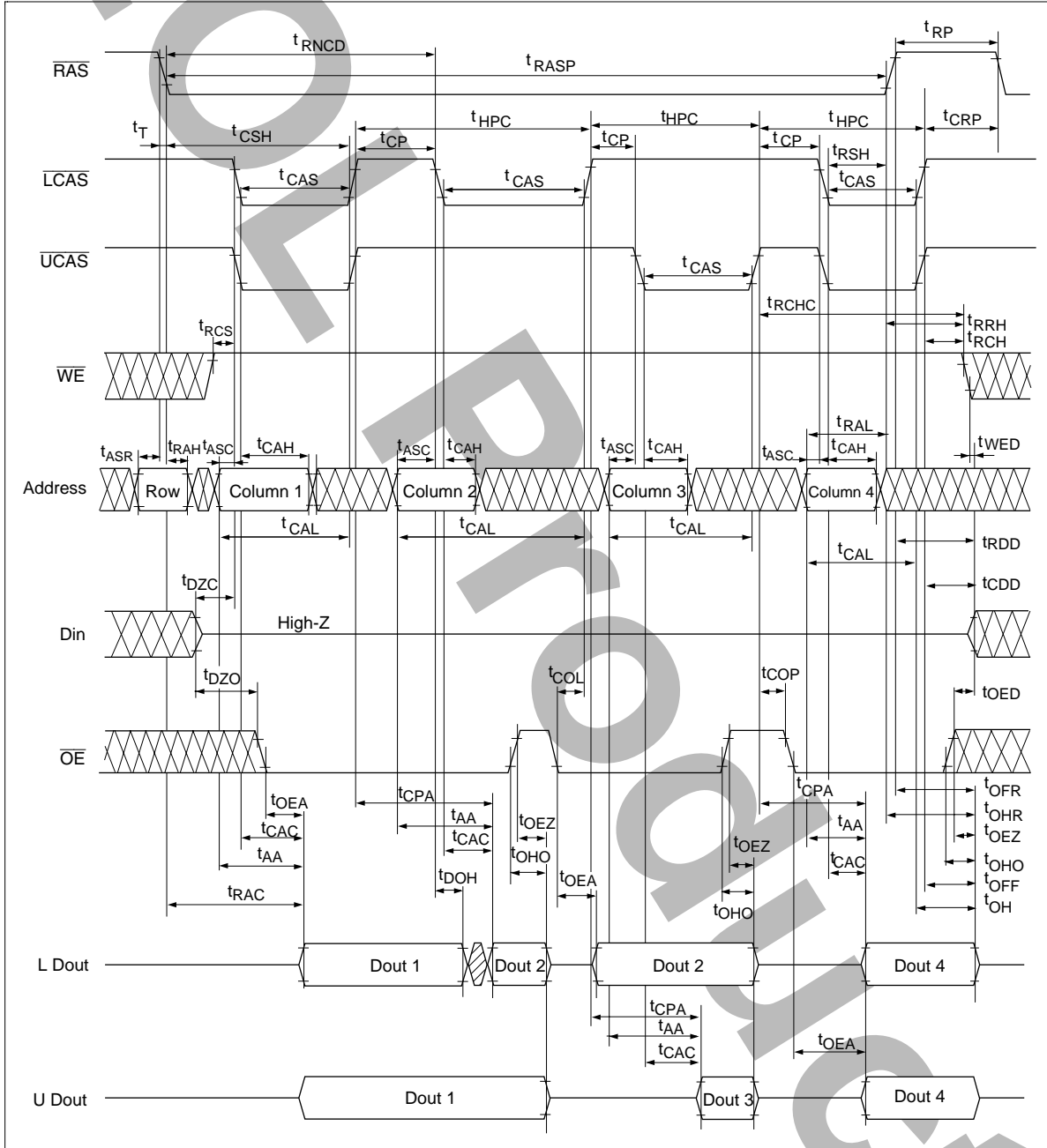

HM51W16165 Series, HM51W18165 Series

EDO Page Mode Early Write Cycle

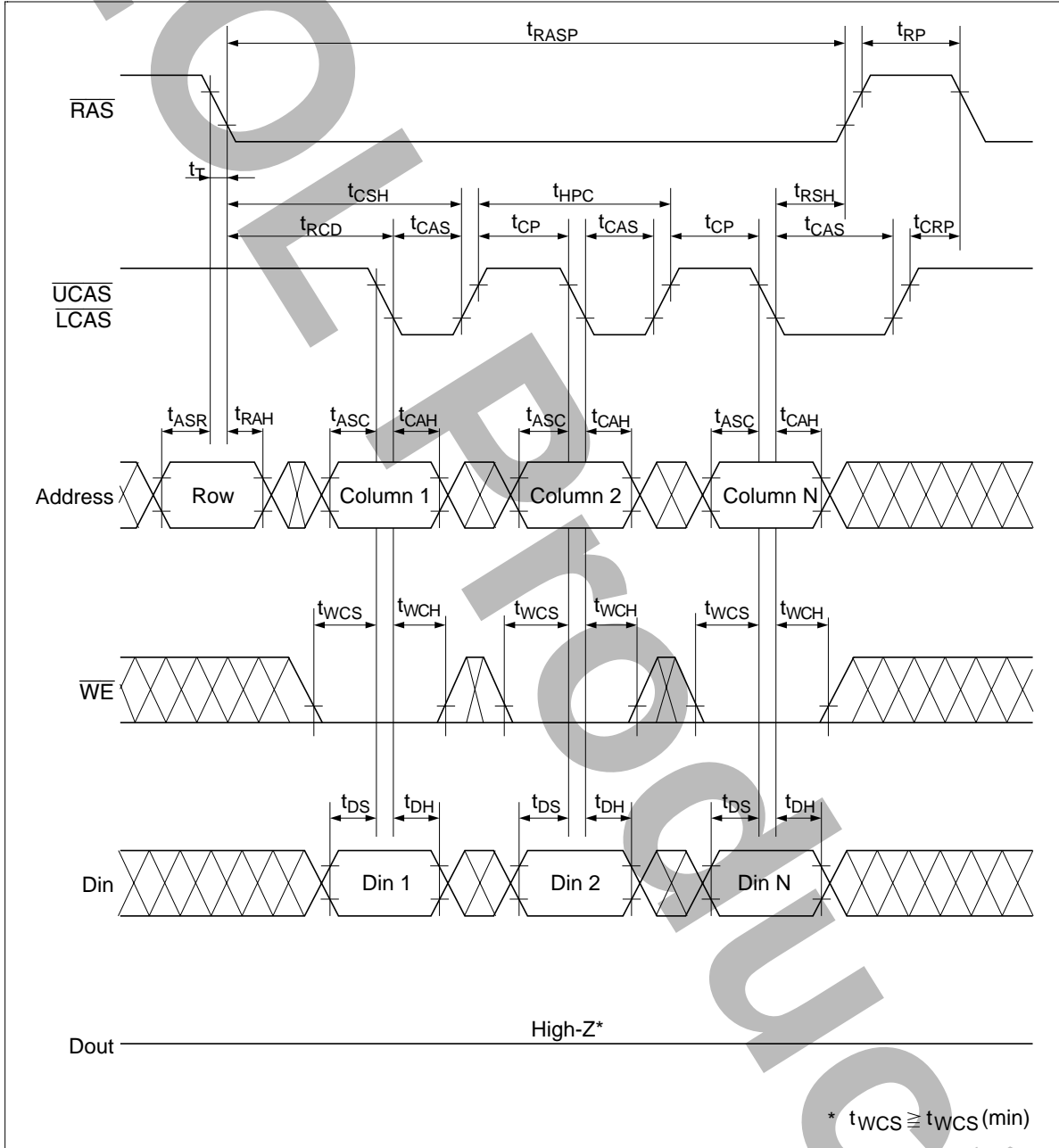

HM51W16165 Series, HM51W18165 Series

EDO Page Mode Read-Modify-Write Cycle*18

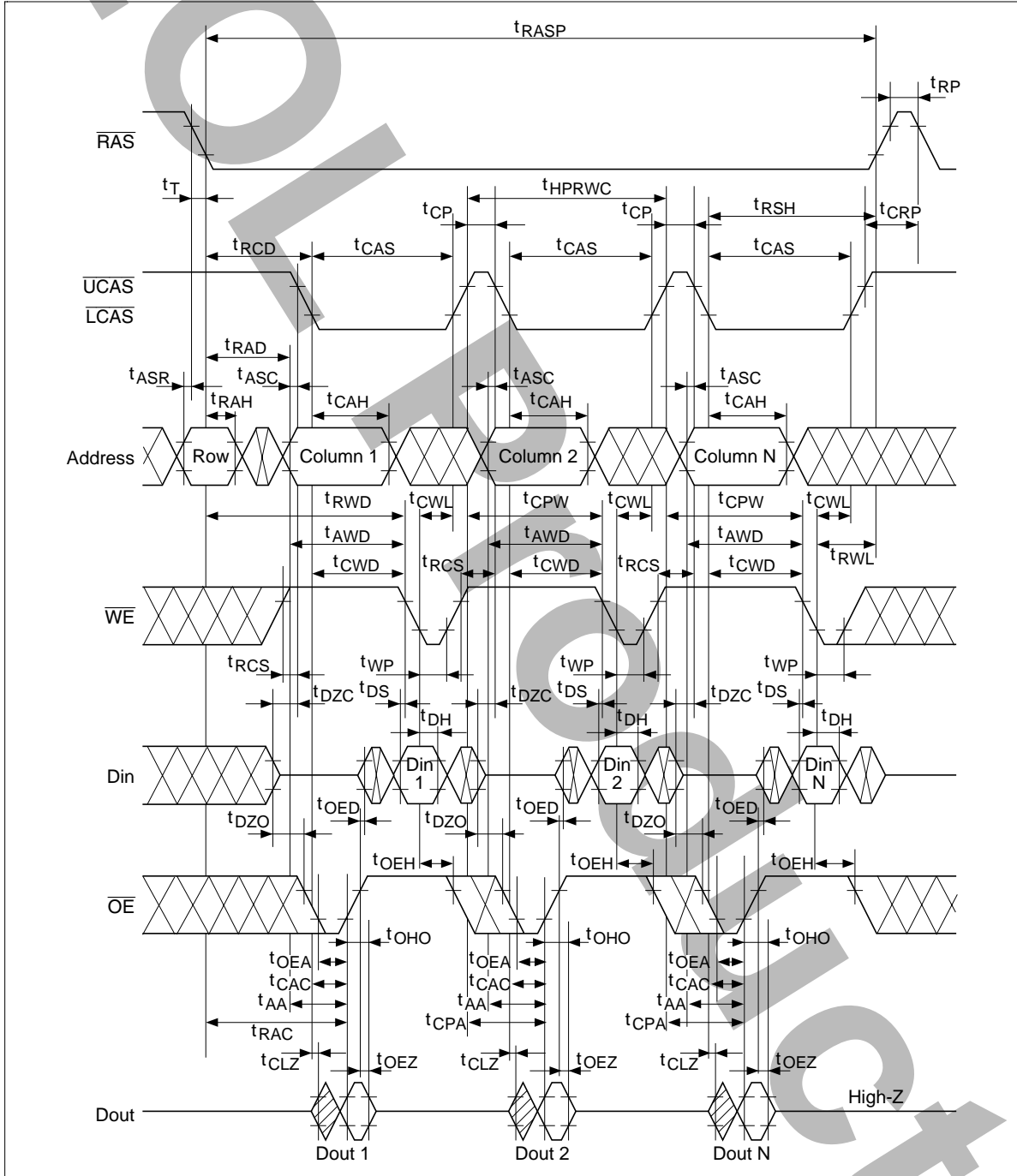

HM51W16165 Series, HM51W18165 Series

Self Refresh Cycle (L-version)*28, *29, *30, *31

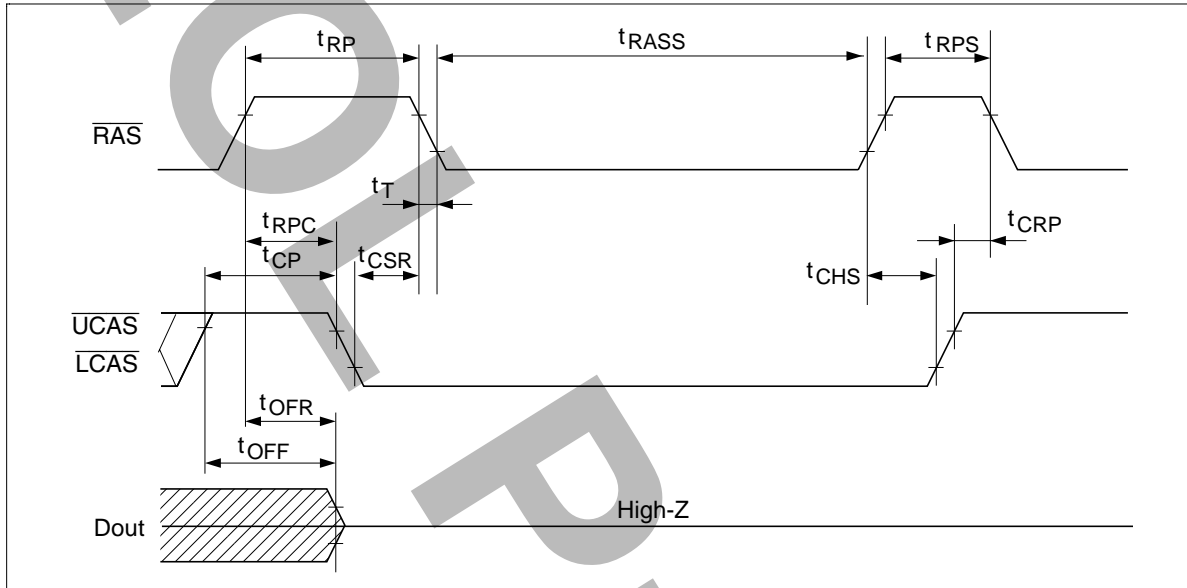

HM51W16165 Series, HM51W18165 Series

Package Dimensions

HM51W16165J/LJ Series

HM51W18165J/LJ Series (CP-42D)

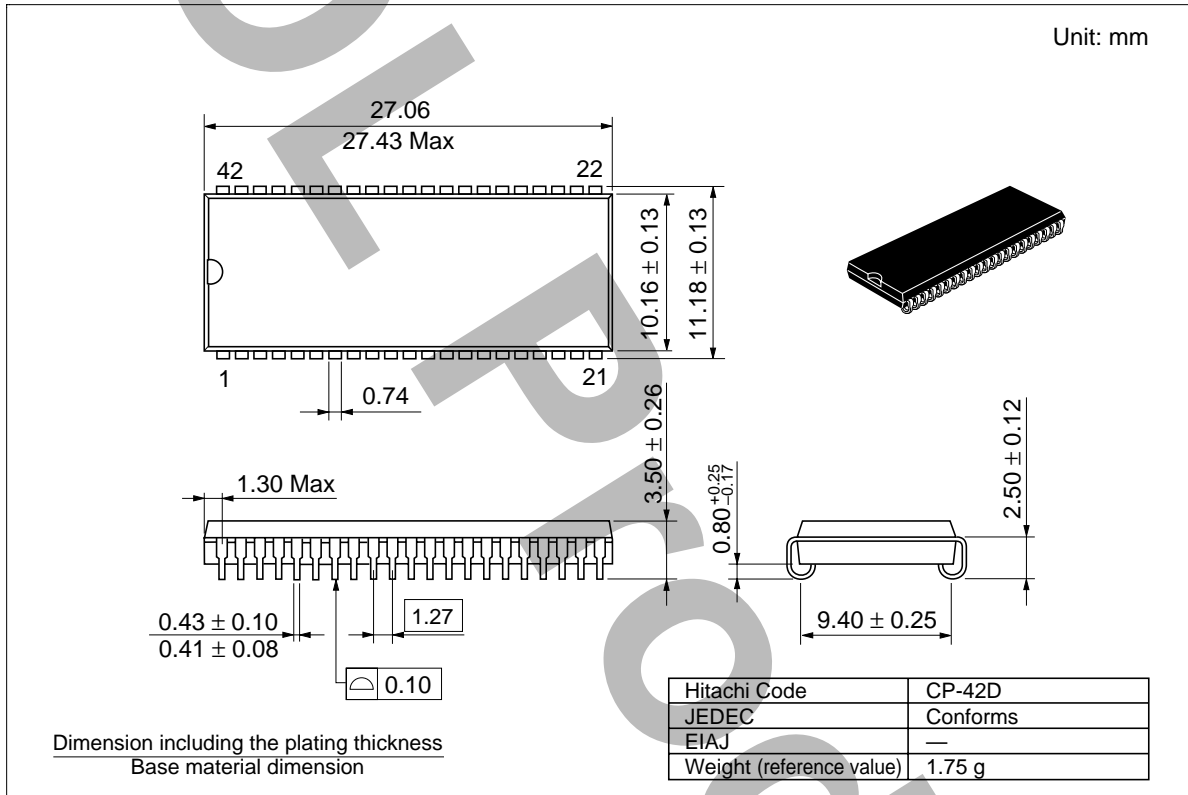

HM51W16165 Series, HM51W18165 Series

HM51W16165TT/LTT Series

HM51W18165TT/LTT Series (TTP-50/44DC)

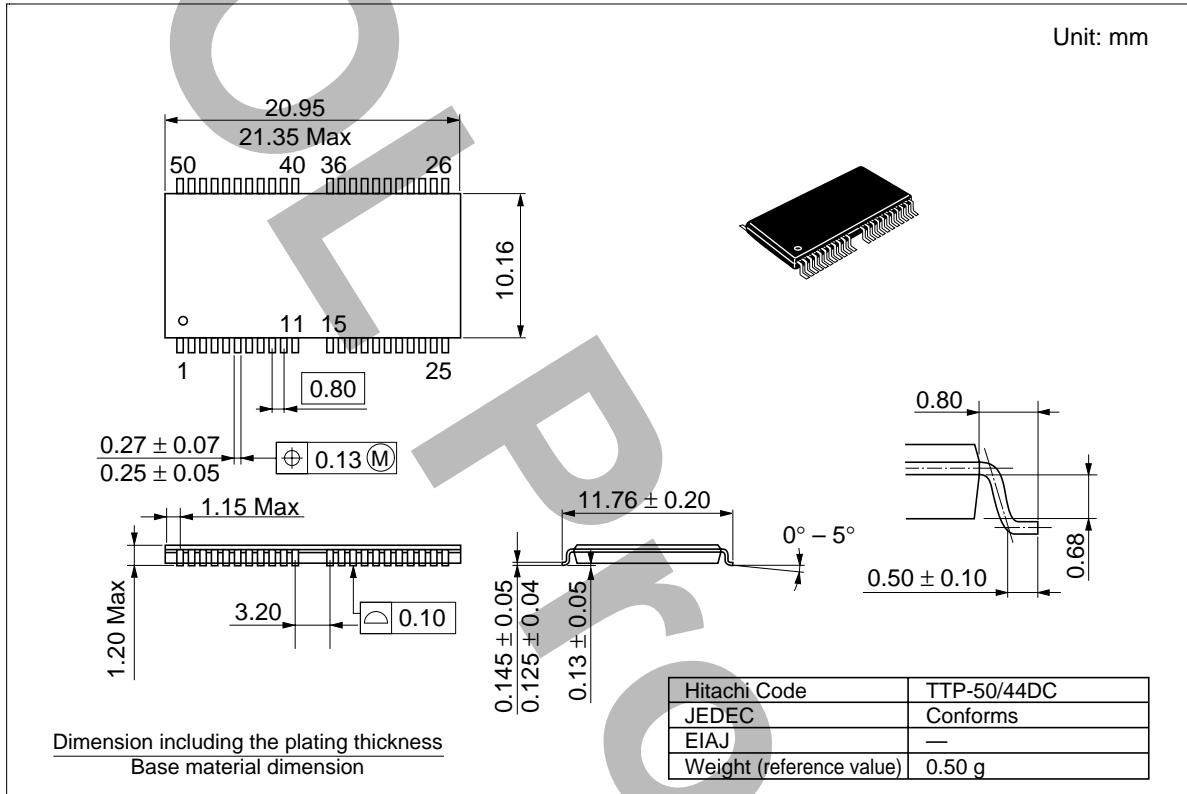

HM51W16165 Series, HM51W18165 Series

Cautions

1. Elpida Memory, Inc. neither warrants nor grants licenses of any rights of Elpida Memory, Inc.'s or any third party's patent, copyright, trademark, or other intellectual property rights for information contained in this document. Elpida Memory, Inc. bears no responsibility for problems that may arise with third party's rights, including intellectual property rights, in connection with use of the information contained in this document.
2. Products and product specifications may be subject to change without notice. Confirm that you have received the latest product standards or specifications before final design, purchase or use.
3. Elpida Memory, Inc. makes every attempt to ensure that its products are of high quality and reliability. However, contact Elpida Memory, Inc. before using the product in an application that demands especially high quality and reliability or where its failure or malfunction may directly threaten human life or cause risk of bodily injury, such as aerospace, aeronautics, nuclear power, combustion control, transportation, traffic, safety equipment or medical equipment for life support.
4. Design your application so that the product is used within the ranges guaranteed by Elpida Memory, Inc. particularly for maximum rating, operating supply voltage range, heat radiation characteristics, installation conditions and other characteristics. Elpida Memory, Inc. bears no responsibility for failure or damage when used beyond the guaranteed ranges. Even within the guaranteed ranges, consider normally foreseeable failure rates or failure modes in semiconductor devices and employ systemic measures such as fail-safes, so that the equipment incorporating Elpida Memory, Inc. product does not cause bodily injury, fire or other consequential damage due to operation of the Elpida Memory, Inc. product.
5. This product is not designed to be radiation resistant.
6. No one is permitted to reproduce or duplicate, in any form, the whole or part of this document without written approval from Elpida Memory, Inc..
7. Contact Elpida Memory, Inc. for any questions regarding this document or Elpida Memory, Inc. semiconductor products.

© Elpida Memory, Inc. 2001