

RB520S-30

$I_o = 200 \text{ mA}$

$V_R = 30 \text{ Volts}$

RoHS Device

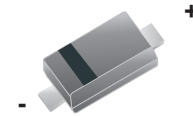

Features

- Low reverse current.
- Designed for mounting on small surface.
- Extremely thin package.
- Majority carrier conduction.

Mechanical data

- Case: SOD-523 standard package, molded plastic.
- Terminals: solderable per MIL-STD-750, method 2026.
- Marking code: cathode band & B
- Mounting position: Any
- Weight: 0.0012 gram(approx.).

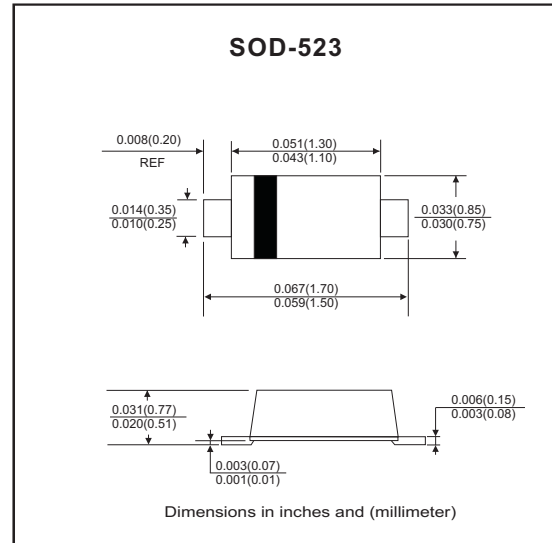

Circuit Diagram



Maximum Ratings (at $T_A=25^\circ\text{C}$ unless otherwise noted)

Parameter	Conditions	Symbol	Min	Typ	Max	Unit
DC Reverse voltage		V_R			30	V
Mean rectifying current		I_o			200	mA
Peak forward surge current	8.3ms single half sine-wave superimposed on rate load(JEDEC method)	I_{FSM}			1	A
Storage temperature		T_{STG}	-40		+125	$^\circ\text{C}$
Junction temperature		T_j			+125	$^\circ\text{C}$

Electrical Characteristics (At $T_a=25^\circ\text{C}$, unless otherwise noted)

Parameter	Conditions	Symbol	Min	Typ	Max	Unit
Forward voltage	$I_F = 200 \text{ mA}$	V_F			0.6	V
Reverse current	$V_R = 10 \text{ V}$	I_R			1	μA

RATING AND CHARACTERISTIC CURVES (RB520S-30)

Fig.1 Forward Characteristics

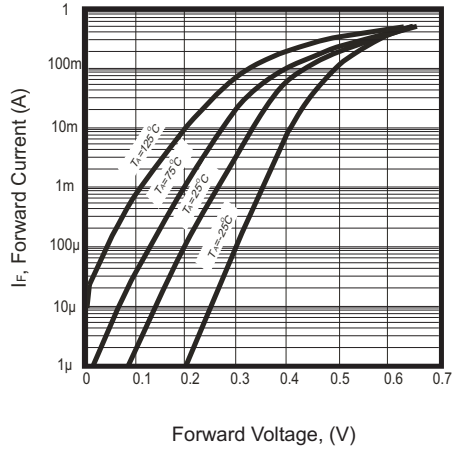

Fig. 2 - Reverse characteristics

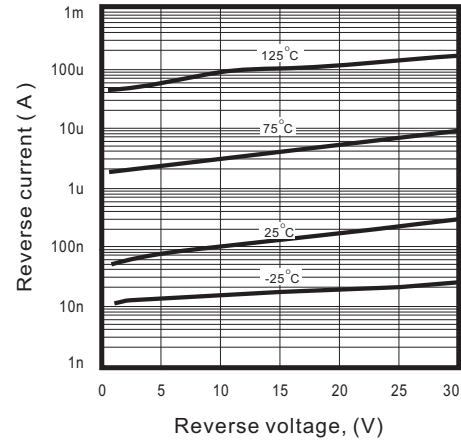

Fig. 3 - Capacitance between terminals characteristics

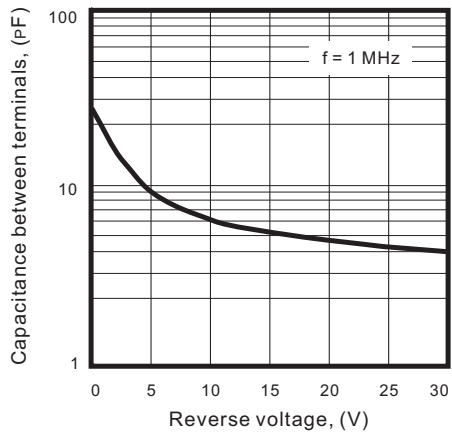
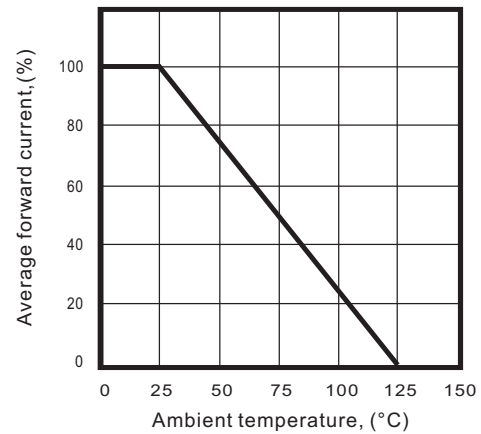
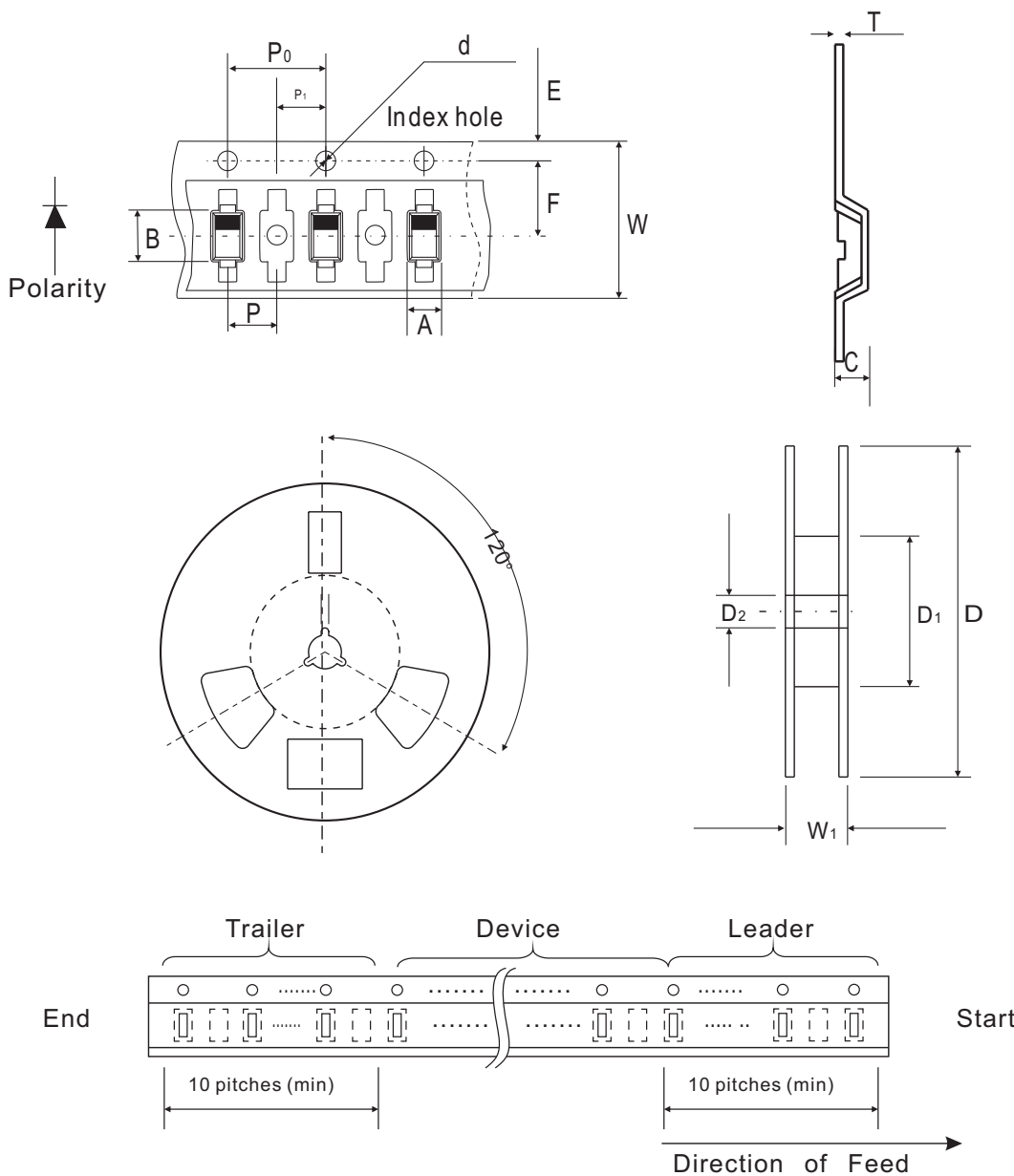

Fig.4 - Derating curve
(Mounting on glass epoxy PCBs)



Reel Taping Specification



SOD-523	SYMBOL	A	B	C	d	D	D1	D2
	(mm)	0.90 ± 0.10	1.94 ± 0.10	0.73 ± 0.10	1.50 ± 0.10	178 ± 1.00	54.40 ± 0.40	13.00 ± 0.20
	(inch)	0.035 ± 0.004	0.076 ± 0.004	0.029 ± 0.004	0.059 ± 0.004	7.008 ± 0.039	2.142 ± 0.016	0.512 ± 0.008

SOD-523	SYMBOL	E	F	P	P0	P1	W	W1
	(mm)	1.75 ± 0.10	3.50 ± 0.05	2.00 ± 0.10	4.00 ± 0.10	2.00 ± 0.10	8.00 ± 0.30 / - 0.10	9.50 ± 1.00
	(inch)	0.069 ± 0.004	0.138 ± 0.002	0.079 ± 0.004	0.158 ± 0.004	0.079 ± 0.004	0.315 ± 0.012 / - 0.004	0.374 ± 0.039

Marking Code

Part Number	Marking Code
RB520S-30	B



Suggested PAD Layout

SIZE	SOD-523	
	(mm)	(inch)
A	1.40	0.055
B	0.60	0.024
C	0.70	0.028
D	2.00	0.079
E	0.80	0.031

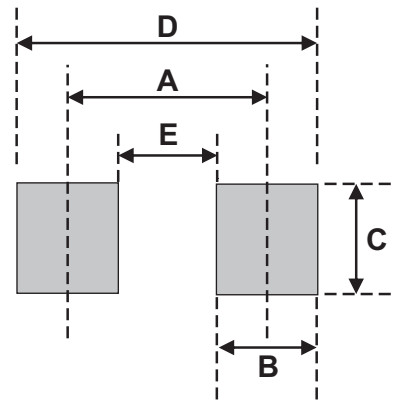

Standard Packaging

Case Type	REEL PACK	
	REEL (pcs)	Reel Size (inch)
SOD-523	3,000	7