

64M-BIT (8M x 8 / 4M x 16) Mask ROM with Page Mode

FEATURES

- Bit organization
 - 8M x 8 (byte mode)
 - 4M x 16 (word mode)
- Fast access time
 - Random access: 100ns (max.)
 - Page access: 30ns (max.)
- Page Size
 - 8 words per page
- Current
 - Operating: 50mA
 - Standby: 15uA (max.)
- Supply voltage
 - 2.7V~3.6V
- Package
 - 44 pin SOP (500 mil)
 - 48 pin TSOP (12mm x 20mm)

PIN CONFIGURATION

44 SOP

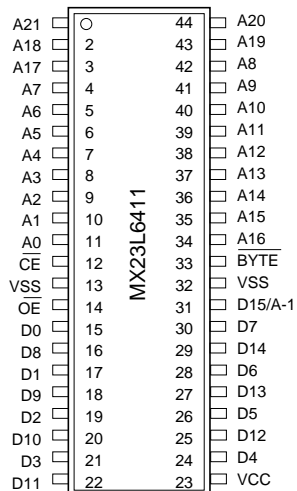

ORDER INFORMATION

Part No.	Access Time	Page Access Time	Package
MX23L6411MC-12	120ns	50ns	44 pin SOP
MX23L6411TC-12	120ns	50ns	48 pin TSOP
MX23L6411RC-12	120ns	50ns	48 pin TSOP (Reverse type)
MX23L6411MC-10	100ns	30ns	44 pin SOP
MX23L6411TC-10	100ns	30ns	48 pin TSOP
MX23L6411RC-10	100ns	30ns	48 pin TSOP (Reverse type)

PIN DESCRIPTION

Symbol	Pin Function
A0~A21	Address Inputs
D0~D14	Data Outputs
D15/A-1	D15 (Word Mode) / LSB Address (Byte Mode)
CE	Chip Enable Input
OE	Output Enable Input
Byte	Word / Byte Mode Selection
VCC	Power Supply Pin
VSS	Ground Pin
NC	No Connection

MODE SELECTION

CE	OE	Byte	D15/A-1	D0~D7	D8~D15	Mode	Power
H	X	X	X	High Z	High Z	-	Stand-by
L	H	X	X	High Z	High Z	-	Active
L	L	H	Output	D0~D7	D8~D15	Word	Active
L	L	L	Input	D0~D7	High Z	Byte	Active

48 TSOP (NORMAL TYPE)

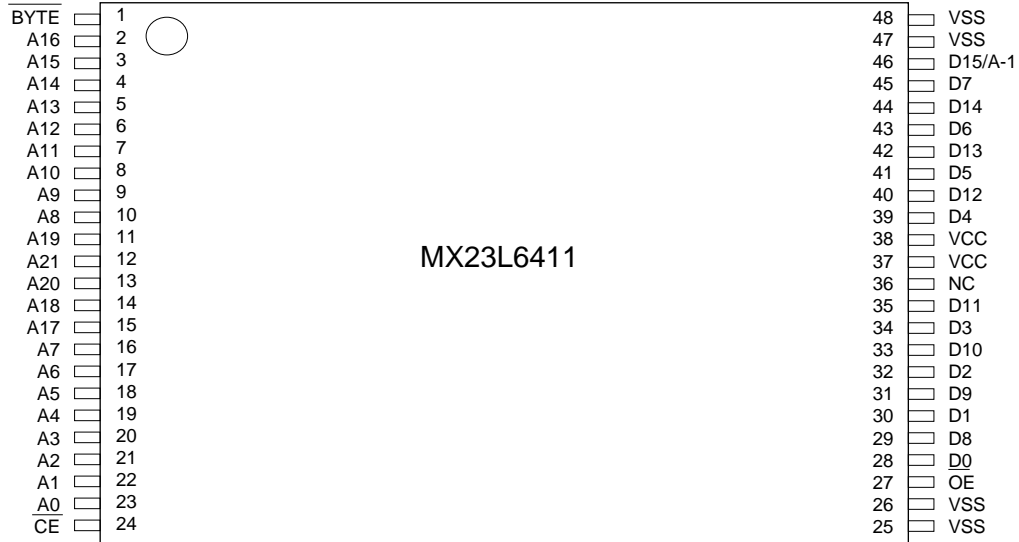

48 TSOP (REVERSE TYPE)

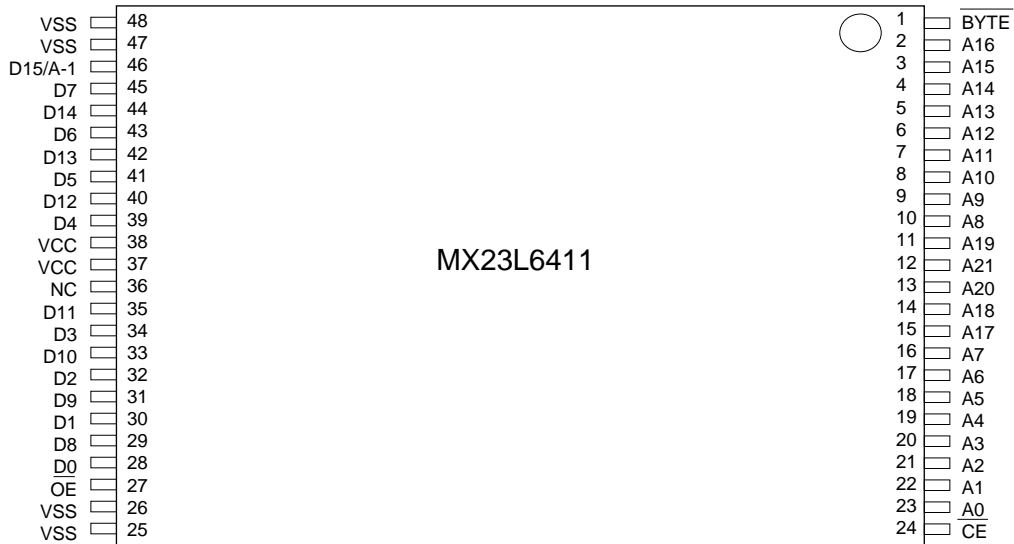

BLOCK DIAGRAM

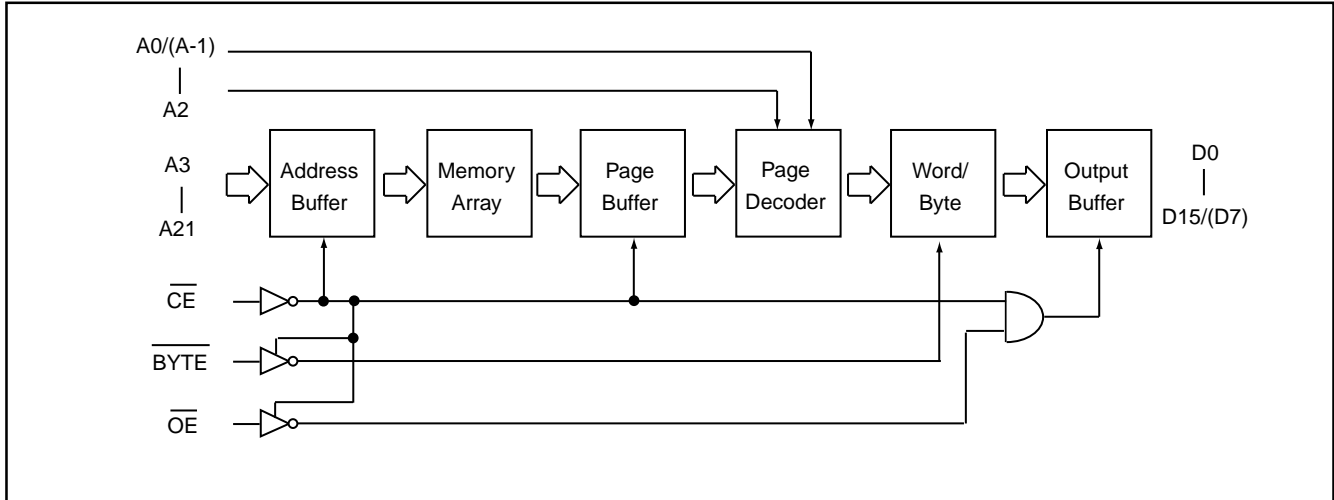

ABSOLUTE MAXIMUM RATINGS

Item	Symbol	Ratings
Supply Voltage Relative to VSS	VCC	-0.3V to 4.3V
Voltage on any Pin Relative to VSS	VIN	-0.5V to VCC + 2V
Ambient Operating Temperature	T _{opr}	0°C to 70°C
Storage Temperature	T _{stg}	-65°C to 125°C

DC CHARACTERISTICS (Ta = 0°C ~ 70°C, VCC = 2.7V~3.6V)

Item	Symbol	MIN.	MAX.	Conditions
Output High Voltage	VOH	2.4V	-	IOH = -0.4mA
Output Low Voltage	VOL	-	0.4V	IOL = 1.6mA
Input High Voltage	VIH	2.2V	VCC+0.3V	
Input Low Voltage	VIL	-0.3V	0.8V	
Input Leakage Current	ILI	-	5uA	0V, VCC
Output Leakage Current	ILO	-	5uA	0V, VCC
Operating Current	ICC1	-	50mA	f=5MHz, all output open
Standby Current (TTL)	ISTB1	-	1mA	$\overline{CE} = V_{IH}$
Standby Current (CMOS)	ISTB2	-	15uA	$\overline{CE} > V_{CC} - 0.2V$
Input Capacitance	CIN	-	10pF	Ta = 25°C, f = 1MHZ
Output Capacitance	COUT	-	10pF	Ta = 25°C, f = 1MHZ

AC CHARACTERISTICS (Ta = 0°C ~ 70°C, VCC = 2.7V~3.6V)

Item	Symbol	23L6411-10		23L6411-12	
		MIN.	MAX.	MIN.	MAX.
Read Cycle Time	tRC	100ns	-	120ns	-
Address Access Time	tAA	-	100ns	-	120ns
Chip Enable Access Time	tACE	-	100ns	-	120ns
Page Mode Access Time	tPA	-	30ns	-	50ns
Output Enable Time	tOE	-	30ns	-	50ns
Output Hold After Address	tOH	0ns	-	0ns	-
Output High Z Delay	tHZ	-	20ns	-	20ns

Note: Output high-impedance delay (tHZ) is measured from \overline{OE} or \overline{CE} going high, and this parameter guaranteed by design over the full voltage and temperature operating range - not tested.

AC Test Conditions

Input Pulse Levels	0.4V~ 2.4V
Input Rise and Fall Times	10ns
Input Timing Level	1.4V
Output Timing Level	1.4V
Output Load	See Figure

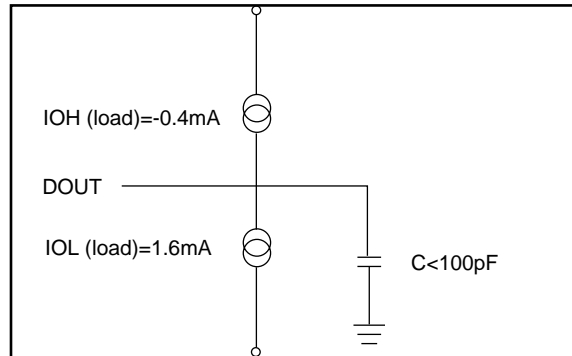

Note: No output loading is present in tester load board.

Active loading is used and under software programming control.

Output loading capacitance includes load board's and all stray capacitance.

TIMING DIAGRAM

RANDOM READ

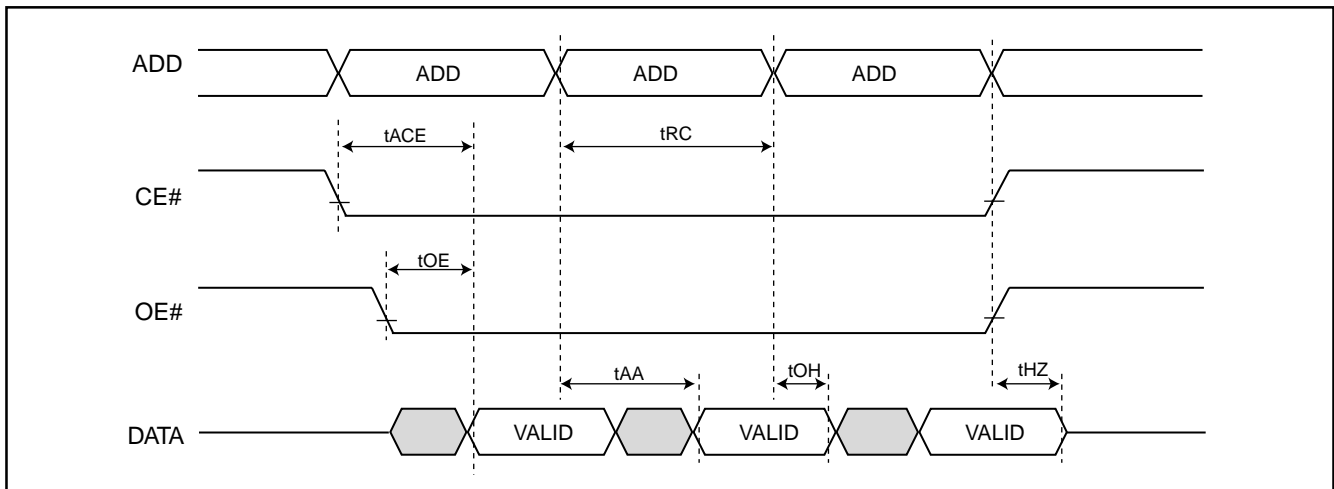

PAGE READ

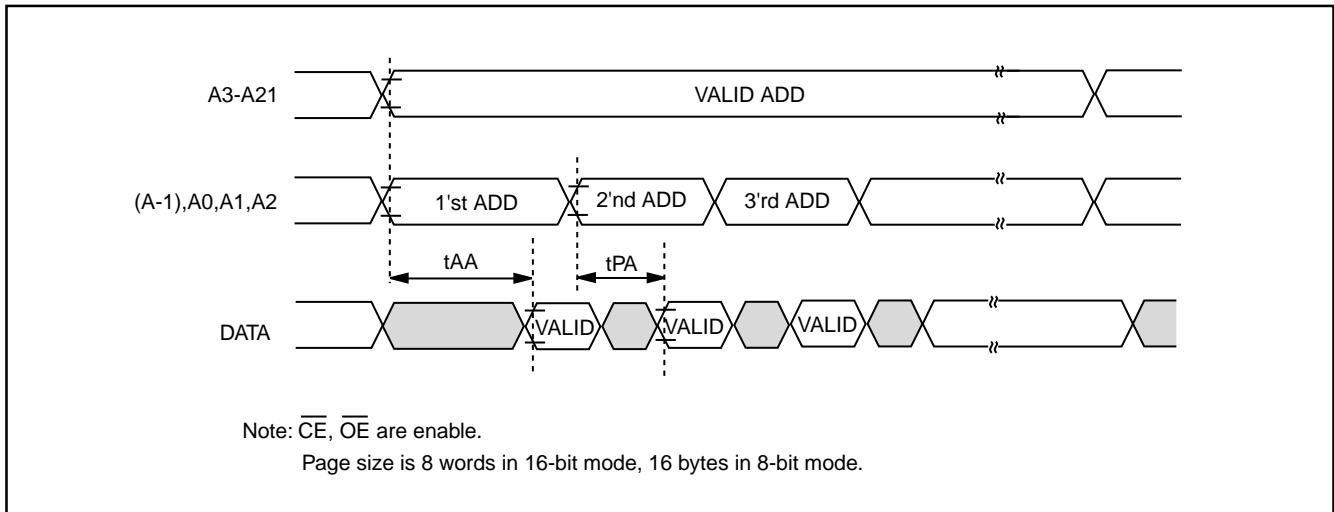

PACKAGE INFORMATION

Title: Package Outline for SOP 44L (500MIL)

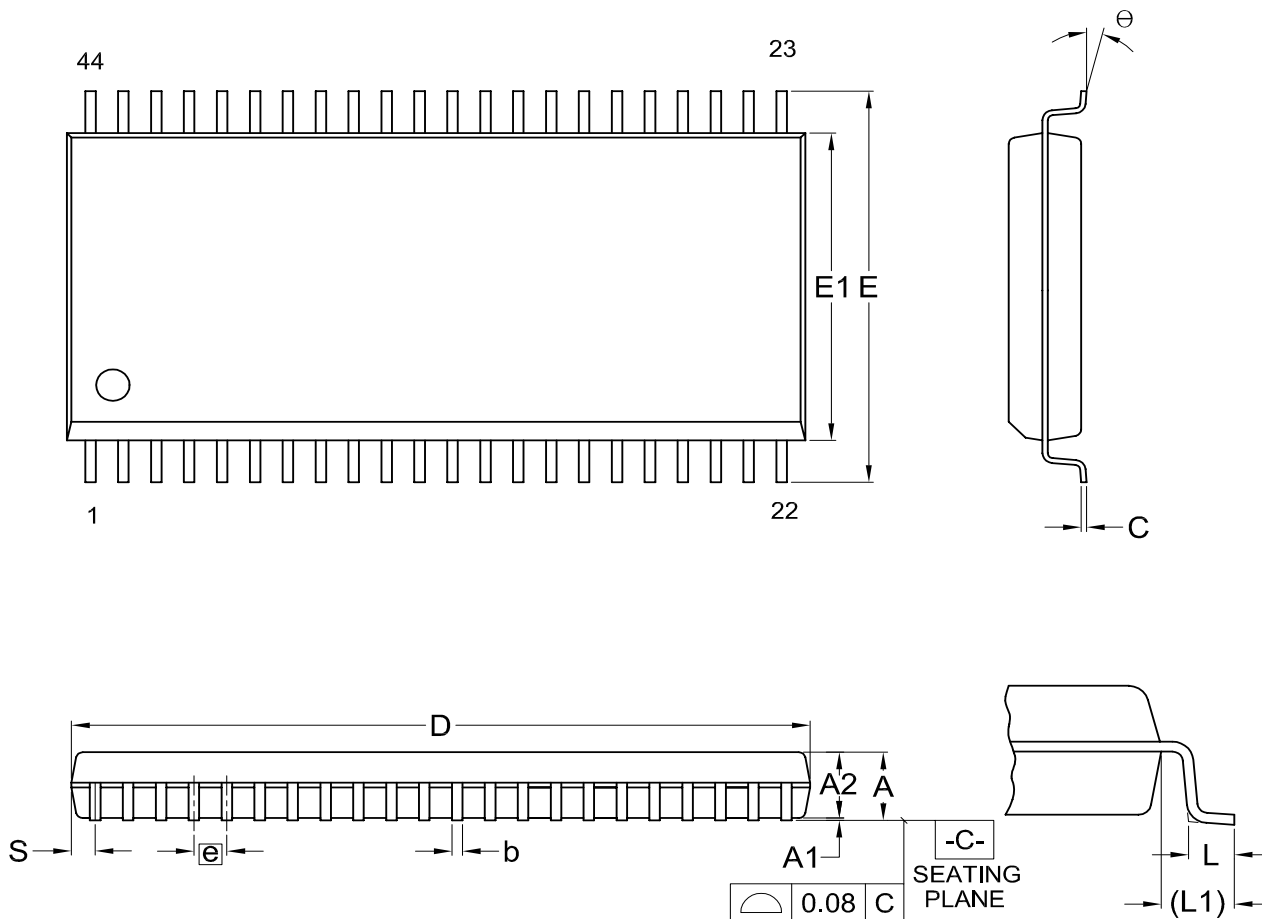

Dimensions (inch dimensions are derived from the original mm dimensions)

SYMBOL		A	A1	A2	b	C	D	E	E1	e	L	L1	S	θ
UNIT														
mm	Min.	---	0.10	2.59	0.36	0.15	28.37	15.83	12.47		0.56	1.51	0.78	0
	Nom.	---	0.15	2.69	0.41	0.20	28.50	16.03	12.60	1.27	0.76	1.71	0.91	5
	Max.	3.00	0.20	2.80	0.51	0.25	28.63	16.23	12.73		0.96	1.91	1.04	10
Inch	Min.	---	0.004	0.102	0.014	0.006	1.117	0.623	0.491		0.022	0.059	0.031	0
	Nom.	---	0.006	0.106	0.016	0.008	1.122	0.631	0.496	0.050	0.030	0.067	0.036	5
	Max.	0.118	0.008	0.110	0.020	0.010	1.127	0.639	0.501		0.038	0.075	0.041	10

DWG.NO.	REVISION	REFERENCE			ISSUE DATE
		JEDEC	EIAJ		
6110-1405	6	MO-175			11-26-'03

Title: Package Outline for TSOP(I) 48L (12X20mm)NORMAL FORM

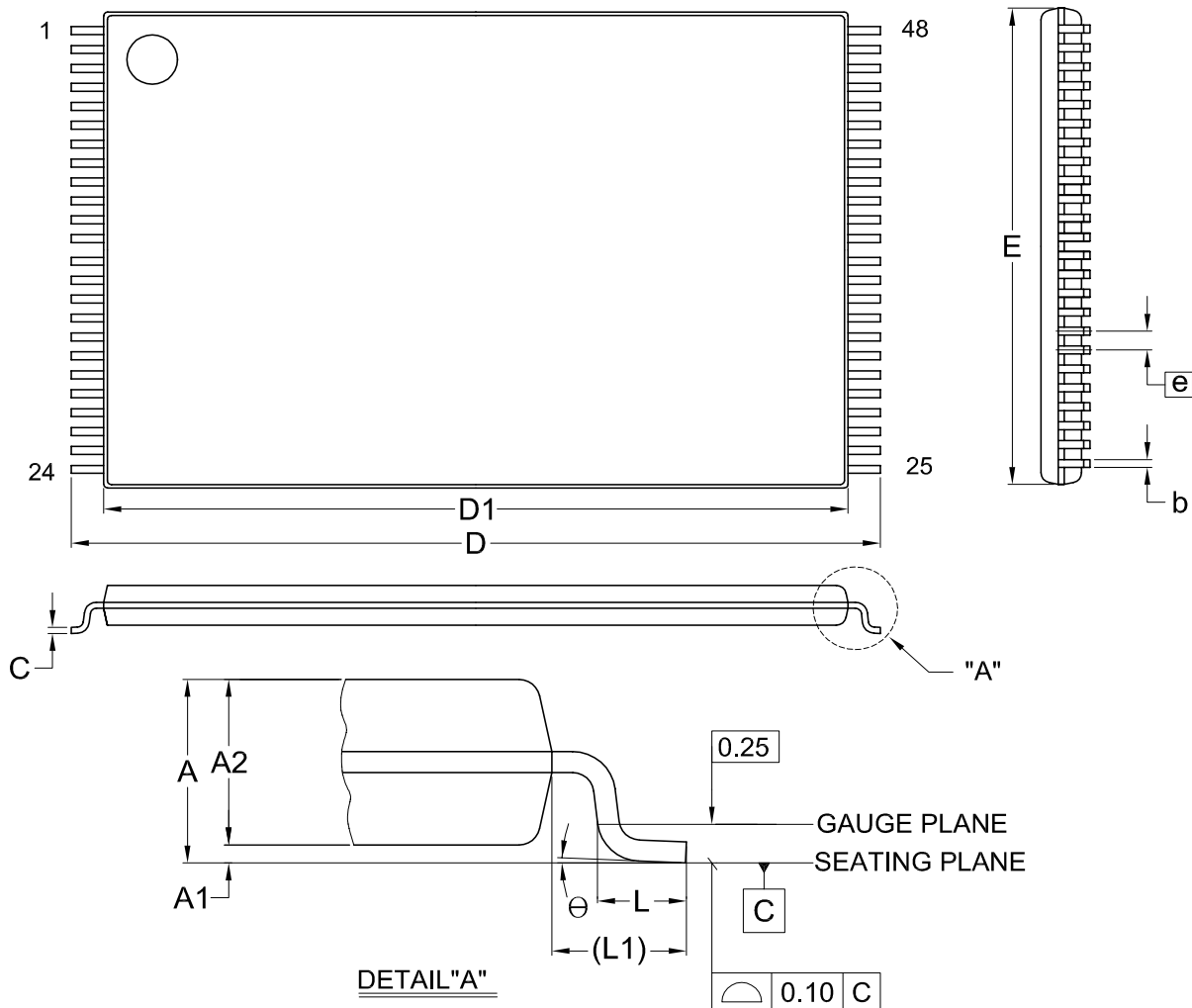

Dimensions (inch dimensions are derived from the original mm dimensions)

SYMBOL		A	A1	A2	b	C	D	D1	E	e	L	L1	θ
UNIT													
mm	Min.	---	0.05	0.95	0.17	0.10	19.80	18.30	11.90	---	0.50	0.70	0
	Nom.	---	0.10	1.00	0.20	0.13	20.00	18.40	12.00	0.50	0.60	0.80	5
	Max.	1.20	0.15	1.05	0.27	0.21	20.20	18.50	12.10	---	0.70	0.90	8
Inch	Min.	---	0.002	0.037	0.007	0.004	0.780	0.720	0.469	---	0.020	0.028	0
	Nom.	---	0.004	0.039	0.008	0.005	0.787	0.724	0.472	0.020	0.024	0.031	5
	Max.	0.047	0.006	0.041	0.011	0.008	0.795	0.728	0.476	---	0.028	0.035	8

DWG.NO.	REVISION	REFERENCE			ISSUE DATE
		JEDEC	EIAJ		
6110-1607	8	MO-142			2007/08/03

Title: Package Outline for TSOP(I) 48L (12X20mm)REVERSE FORM

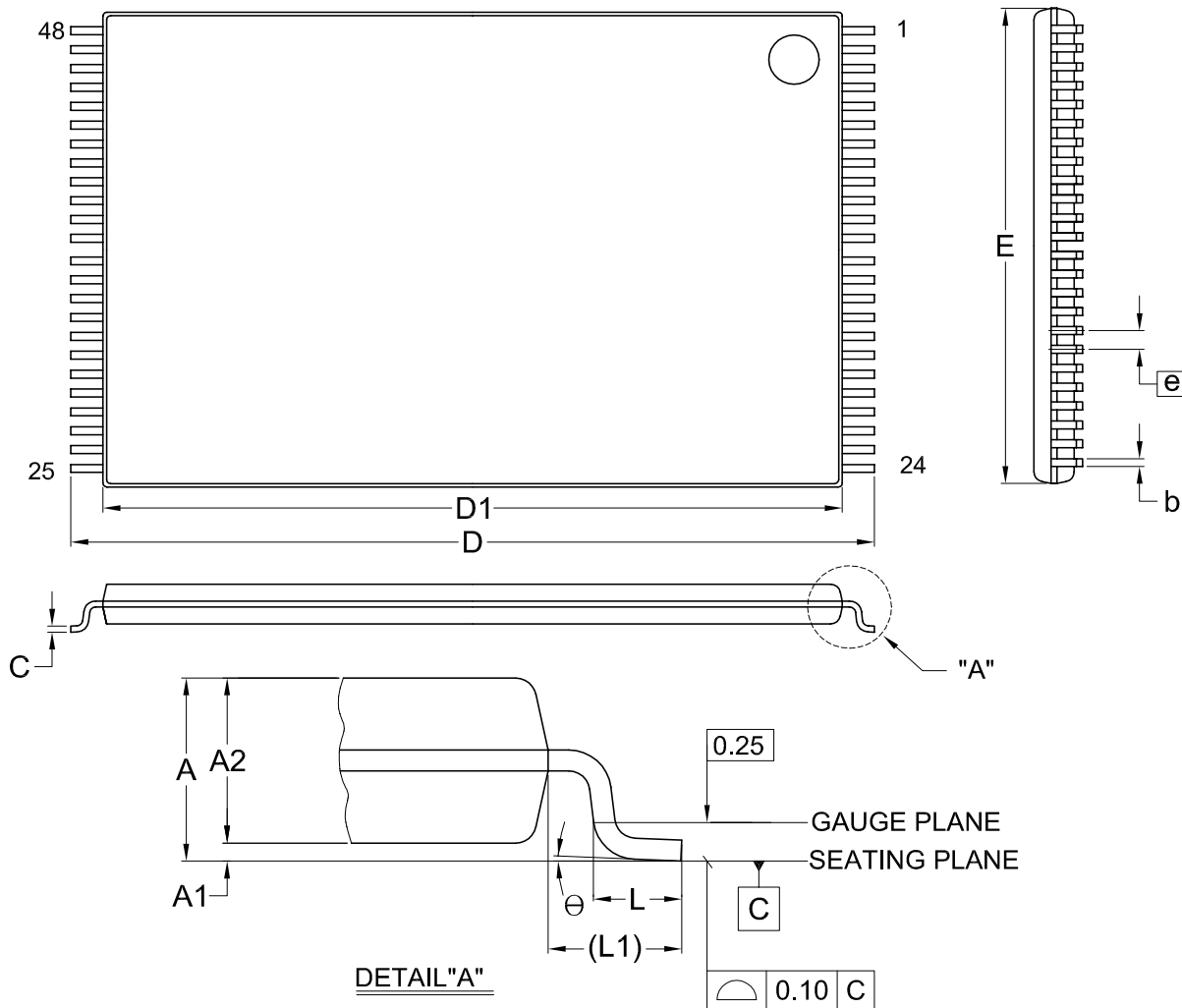

Dimensions (inch dimensions are derived from the original mm dimensions)

SYMBOL		A	A1	A2	b	C	D	D1	E	e	L	L1	θ
UNIT													
mm	Min.	---	0.05	0.95	0.17	0.10	19.80	18.30	11.90	---	0.50	0.70	0
	Nom.	---	0.10	1.00	0.20	0.13	20.00	18.40	12.00	0.50	0.60	0.80	5
	Max.	1.20	0.15	1.05	0.27	0.21	20.20	18.50	12.10	---	0.70	0.90	8
Inch	Min.	---	0.002	0.037	0.007	0.004	0.780	0.720	0.469	---	0.020	0.028	0
	Nom.	---	0.004	0.039	0.008	0.005	0.787	0.724	0.472	0.020	0.024	0.031	5
	Max.	0.047	0.006	0.041	0.011	0.008	0.795	0.728	0.476	---	0.028	0.035	8

DWG.NO.	REVISION	REFERENCE			ISSUE DATE
		JEDEC	EIAJ		
6110-1607.1	9	MO-142			2007/08/07

REVISION HISTORY

REVISION	DESCRIPTION	PAGE	DATE
2.1	AC CHARACTERISTICS tOH 10ns-->0ns	P4	JAN/29/1999
2.2	DC CHARACTERISTICS ISTB2 5uA-->15uA	P4	SEP/03/1999
2.3	DC Characteristics voltage range VCC=2.9V~3.6V-->3.0V~3.6V	P3	DEC/24/1999
2.4	Add 100ns speed grade	P1,4	JUL/02/2000
2.5	Modify Operating Current:60mA-->50mA	P1,4	DEC/29/2000
2.6	Modify Package Information	P6,7	JUL/17/2001
2.7	Change VCC from 3.0~3.6V to 2.7~3.3V	P1,3	AUG/03/2001
2.8	1. Add supply voltage relative to VSS 2. Change voltage on any pin relative to VSS:-0.5V to VCC+2.0	P3 P3	JUL/19/2002
2.9	1. Change supply voltage from 2.7V~3.3V to 2.7V~3.6V	P1,4	SEP/02/2002
3.0	Modify Package Information	P6~8	NOV/22/2002
3.1	1. Added statement	P10	NOV/07/2006



Macronix's products are not designed, manufactured, or intended for use for any high risk applications in which the failure of a single component could cause death, personal injury, severe physical damage, or other substantial harm to persons or property, such as life-support systems, high temperature automotive, medical, aircraft and military application. Macronix and its suppliers will not be liable to you and/or any third party for any claims, injuries or damages that may be incurred due to use of Macronix's products in the prohibited applications.

MACRONIX INTERNATIONAL Co., LTD.

Headquarters

Macronix, Int'l Co., Ltd.
16, Li-Hsin Road, Science Park,
Hsinchu, Taiwan, R.O.C.
Tel: +886-3-5786688
Fax: +886-3-5632888

Macronix America, Inc.

680 North McCarthy Blvd.
Milpitas, CA 95035, U.S.A.
Tel: +1-408-262-8887
Fax: +1-408-262-8810
Email: sales.northamerica@macronix.com

Macronix Japan Cayman Islands Ltd.

NKF Bldg. 5F, 1-2 Higashida-cho,
Kawasaki-ku Kawasaki-shi,
Kanagawa Pref. 210-0005, Japan
Tel: +81-44-246-9100
Fax: +81-44-246-9105

Macronix (Hong Kong) Co., Limited.

702-703, 7/F, Building 9,
Hong Kong Science Park,
5 Science Park West Avenue, Sha Tin, N.T.
Tel: +86-852-2607-4289
Fax: +86-852-2607-4229

http : //www.macronix.com

Taipei Office

Macronix, Int'l Co., Ltd.
19F, 4, Min-Chuan E. Road, Sec. 3,
Taipei, Taiwan, R.O.C.
Tel: +886-2-2509-3300
Fax: +886-2-2509-2200

Macronix Europe N.V.

Koningin Astridlaan 59, Bus 1
1780 Wemmel Belgium
Tel: +32-2-456-8020
Fax: +32-2-456-8021

Singapore Office

Macronix Pte. Ltd.
1 Marine Parade Central
#11-03 Parkway Centre
Singapore 449408
Tel: +65-6346-5505
Fax: +65-6348-8096