



LC75384NE-R, 75384NW

Electronic Volume and Tone Control for Car Stereo Systems



Overview

The LC75384NE-R and LC75384NW are electronic volume and tone control ICs that can implement volume, balance, fader, bass/treble/mid, loudness, input switching, and input gain control functions with a minimum number of external components.

Features

- Volume: 81 positions: from 0 dB to -79 dB in 1-dB steps and $-\infty$.
A balance function can be implemented by controlling the left and right volume settings independently.
- Fader: Either the rear or front outputs can be attenuated over 16 positions. (16 positions: From 0 dB to -2 dB in 1-dB steps, from -2 dB to -20 dB in 2-dB steps, from -20 to -30 dB in one 10-dB step, -45 dB, -60 dB, and $-\infty$.)
- Bass/treble/mid: Control over ± 12 dB in 2-dB steps in each band.
- Input gain: The input signal can be amplified by from 0 dB to $+18.75$ dB in 1.25-dB steps.
- Input switching: The left and right channels can each be selected from one of 5 inputs. (Four are single-ended inputs and one is a differential input.)
- Loudness: Taps are output from a 2-dB step volume control ladder resistor starting at the -32 -dB position. A loudness function can be implemented by attaching external capacitors and resistors.
- On-chip buffer amplifiers minimize the number of required external components.
- Minimal switching noise when no input signals are present due to fabrication in a silicon gate CMOS process that minimizes the noise generated by internal switches.
- Use of zero-cross switching circuits for internal switches minimizes switching noise when signals are present.
- Built-in $V_{DD}/2$ reference voltage generator circuit
- All controls can be set from serial input data.

- CCB is a trademark of SANYO ELECTRIC CO., LTD.
- CCB is SANYO's original bus format and all the bus addresses are controlled by SANYO.

- Any and all SANYO products described or contained herein do not have specifications that can handle applications that require extremely high levels of reliability, such as life-support systems, aircraft's control systems, or other applications whose failure can be reasonably expected to result in serious physical and/or material damage. Consult with your SANYO representative nearest you before using any SANYO products described or contained herein in such applications.
- SANYO assumes no responsibility for equipment failures that result from using products at values that exceed, even momentarily, rated values (such as maximum ratings, operating condition ranges, or other parameters) listed in products specifications of any and all SANYO products described or contained herein.

SANYO Electric Co., Ltd. Semiconductor Company
TOKYO OFFICE Tokyo Bldg., 1-10, 1 Chome, Ueno, Taito-ku, TOKYO, 110-8534 JAPAN

51000TH (OT) No.6169-1/25

Package Dimensions

unit: mm

3159-QIP64E

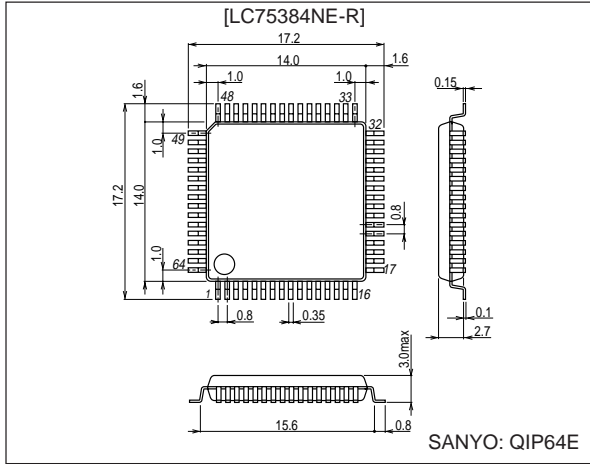

3190-SQFP64

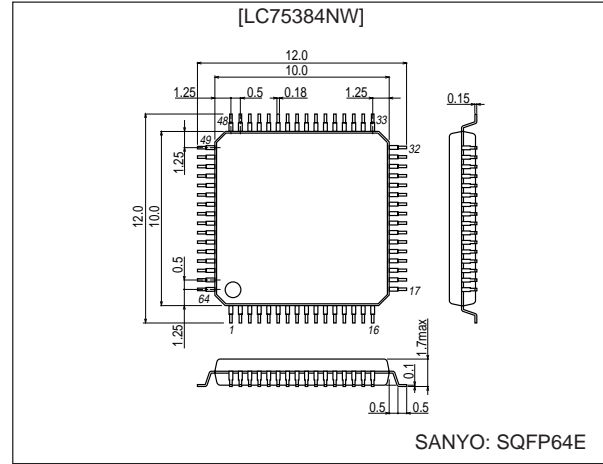

Specifications

Absolute Maximum Ratings at $T_a = 25^\circ\text{C}$, $V_{SS} = 0\text{ V}$

| Parameter | Symbol | Conditions | Ratings | Unit | |
|-----------------------------|---------------------|---|----------------------------------|------------------|----|
| Maximum supply voltage | $V_{DD\text{ max}}$ | V_{DD} | 11 | V | |
| Maximum input voltage | $V_{IN\text{ max}}$ | All input pins | $V_{SS} - 0.3$ to $V_{DD} + 0.3$ | V | |
| Allowable power dissipation | $Pd\text{ max}$ | $T_a \leq 85^\circ\text{C}$, when mounted on a printed circuit board | LC75384NE-R LC75384NW | 500 420 | mW |
| Operating temperature | T_{opr} | | -40 to +85 | $^\circ\text{C}$ | |
| Storage temperature | T_{stg} | | -50 to +125 | $^\circ\text{C}$ | |

Allowable Operating Ranges at $T_a = 25^\circ\text{C}$, $V_{SS} = 0\text{ V}$

| Parameter | Symbol | Conditions | Ratings | | | Unit |
|--------------------------|-------------|------------------|----------|-----|----------|---------------|
| | | | min | typ | max | |
| Supply voltage | V_{DD} | V_{DD} | 6.0 | | 10.5 | V |
| Input high-level voltage | V_{IH} | CL, DI, CE, MUTE | 4.0 | | V_{DD} | V |
| Input low-level voltage | V_{IL} | CL, DI, CE, MUTE | V_{SS} | | 1.0 | V |
| Input voltage amplitude | V_{IN} | | V_{SS} | | V_{DD} | Vp-p |
| Input pulse width | t_{pW} | CL | 1 | | | μs |
| Setup time | t_{setup} | CL, DI, CE | 1 | | | μs |
| Hold time | t_{hold} | CL, DI, CE | 1 | | | μs |
| Operating frequency | fopg | CL | | | 500 | kHz |

LC75384NE-R, 75384NW

Electrical Characteristics at $T_a = 25^\circ\text{C}$, $V_{DD} = 9\text{ V}$, $V_{SS} = 0\text{ V}$

| Parameter | Symbol | Pins | Conditions | Ratings | | | Unit |
|--------------------------|--------------------|----------------------------|------------------|---------|----------|-----------|------------|
| | | | | min | typ | max | |
| [Input Block] | | | | | | | |
| Input resistance | R _{in} | L1 to L4, R1 to R4 | | 30 | 50 | 70 | k Ω |
| Minimum input gain | G _{inmin} | L1 to L4, R1 to R4 | | -1 | 0 | +1 | dB |
| Maximum input gain | G _{inmax} | | | +16.5 | +18.75 | +21 | dB |
| Inter-step setting error | A _{Terr} | | | | | ± 0.6 | dB |
| Left/right balance | BAL | | | | | ± 0.5 | dB |
| [Volume Block] | | | | | | | |
| Input resistance | R _{vr} | LVRIN, RVRIN, loudness off | | 113 | 226 | 339 | k Ω |
| Inter-step setting error | A _{Terr} | | | | | ± 0.5 | dB |
| Left/right balance | BAL | | | | | ± 0.5 | dB |
| [Tone Control Block] | | | | | | | |
| Inter-step setting error | A _{Terr} | | | | | ± 1.0 | dB |
| Bass control range | G _{bass} | | max. boost/cut | ± 9 | ± 12 | ± 15 | dB |
| Mid control range | G _{mid} | | max. boost/cut | ± 9 | ± 12 | ± 15 | dB |
| Treble control range | G _{tre} | | max. boost/cut | ± 9 | ± 12 | ± 15 | dB |
| Left/right balance | BAL | | | | | ± 0.5 | dB |
| [Fader Block] | | | | | | | |
| Input resistance | R _{fed} | LFIN, RFIN | | 25 | 50 | 100 | k Ω |
| Inter-step setting error | A _{Terr} | | 0 dB to -2 dB | | | ± 0.5 | dB |
| | | | -2 dB to -20 dB | | | ± 1 | dB |
| | | | -20 dB to -30 dB | | | ± 2 | dB |
| | | | -30 dB to -60 dB | | | ± 3 | dB |
| Left/right balance | BAL | | | | | ± 0.5 | dB |

Overall Characteristics

| Parameter | Symbol | Conditions | Ratings | | | Unit |
|------------------------------|----------------------|---|---------|-------|-----|---------------|
| | | | min | typ | max | |
| Total harmonic distortion | THD 1 | $V_{IN} = -10\text{ dBV}$, $f = 1\text{ kHz}$ | | 0.004 | | % |
| | THD 2 | $V_{IN} = -10\text{ dBV}$, $f = 10\text{ kHz}$ | | 0.006 | | % |
| Inter-input crosstalk | CT | $V_{IN} = 1\text{ Vrms}$, $f = 1\text{ kHz}$ | 80 | 88 | | dB |
| Left/right channel crosstalk | CT | $V_{IN} = 1\text{ Vrms}$, $f = 1\text{ kHz}$ | 80 | 88 | | dB |
| Maximum attenuation | V _{O min 1} | $V_{IN} = 1\text{ Vrms}$, $f = 1\text{ kHz}$ | 80 | 88 | | dB |
| | V _{O min 2} | $V_{IN} = 1\text{ Vrms}$, $f = 1\text{ kHz}$, INMUTE, with the fader set to $-\infty$ | 90 | 95 | | dB |
| Output noise voltage | V _{N 1} | All controls flat, with the IHF-A filter | | 5 | 10 | μV |
| | V _{N 2} | All controls flat, with a 20 Hz to 20 kHz bandpass filter | | 7 | 15 | μV |
| Current drain | I _{DD} | | | 33 | 40 | mA |
| Input high-level current | I _{IH} | CL, DI, CE, $V_{IN} = 9\text{ V}$ | | | 10 | μA |
| Input low-level current | I _{IL} | CL, DI, CE, $V_{IN} = 0\text{ V}$ | -10 | | | μA |
| Maximum input voltage | V _{CL} | THD = 1 %, R _L = 10 k Ω , all controls flat, $f_{IN} = 1\text{ kHz}$ | 2.5 | 2.9 | | Vrms |
| Common-mode rejection ratio | CMRR | $V_{IN} = 0\text{ dBV}$, $f = 1\text{ kHz}$ | 45 | | | dB |

LC75384NE-R, 75384NW

[LC75384NE-R]

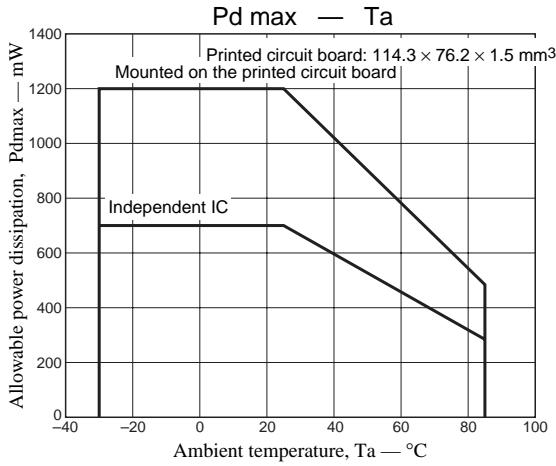

[LC75384NW]

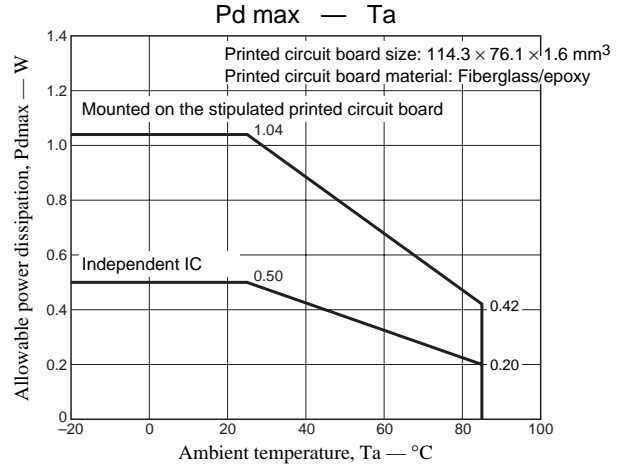

Pin Assignment

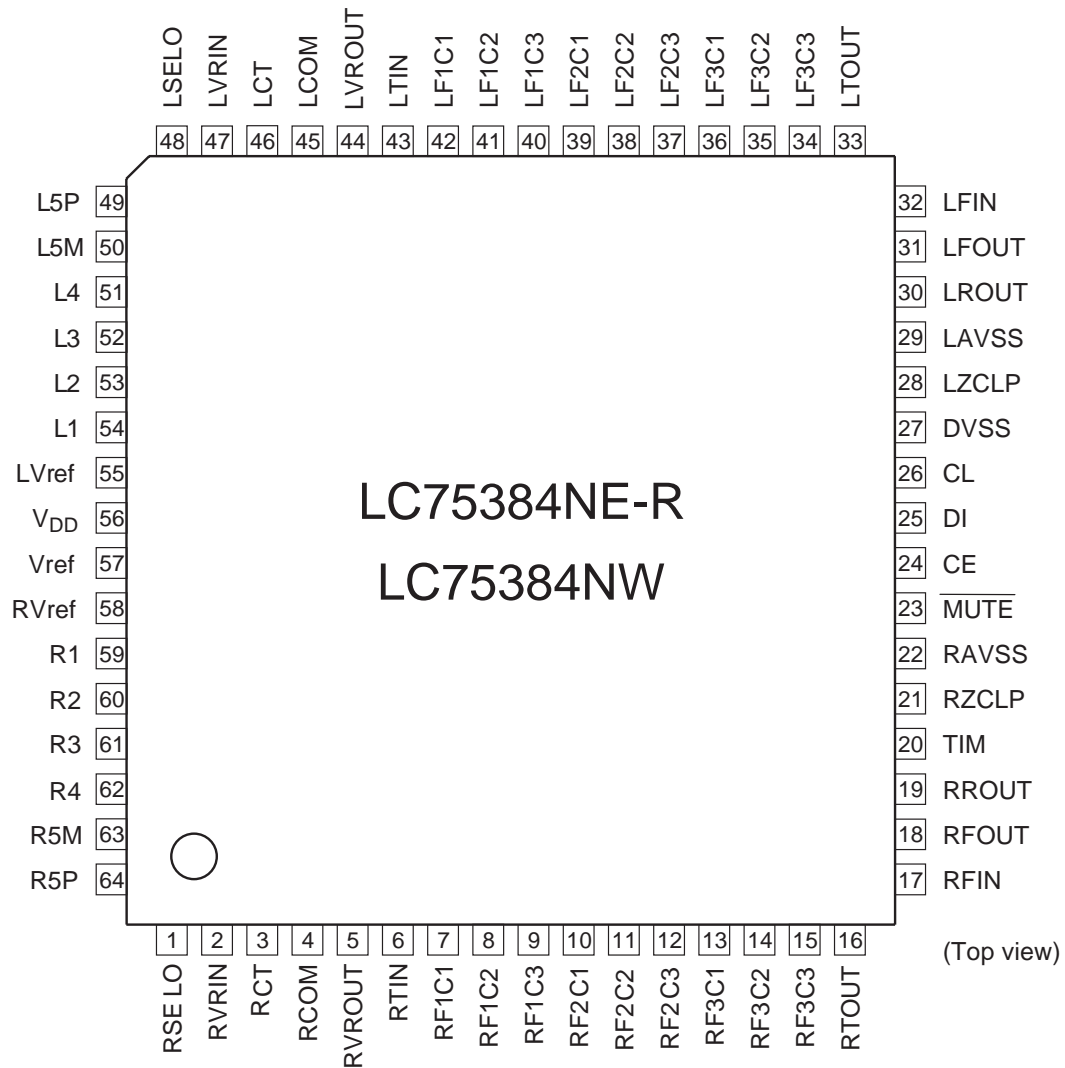

Equivalent Circuit and Sample Application Circuit Diagram

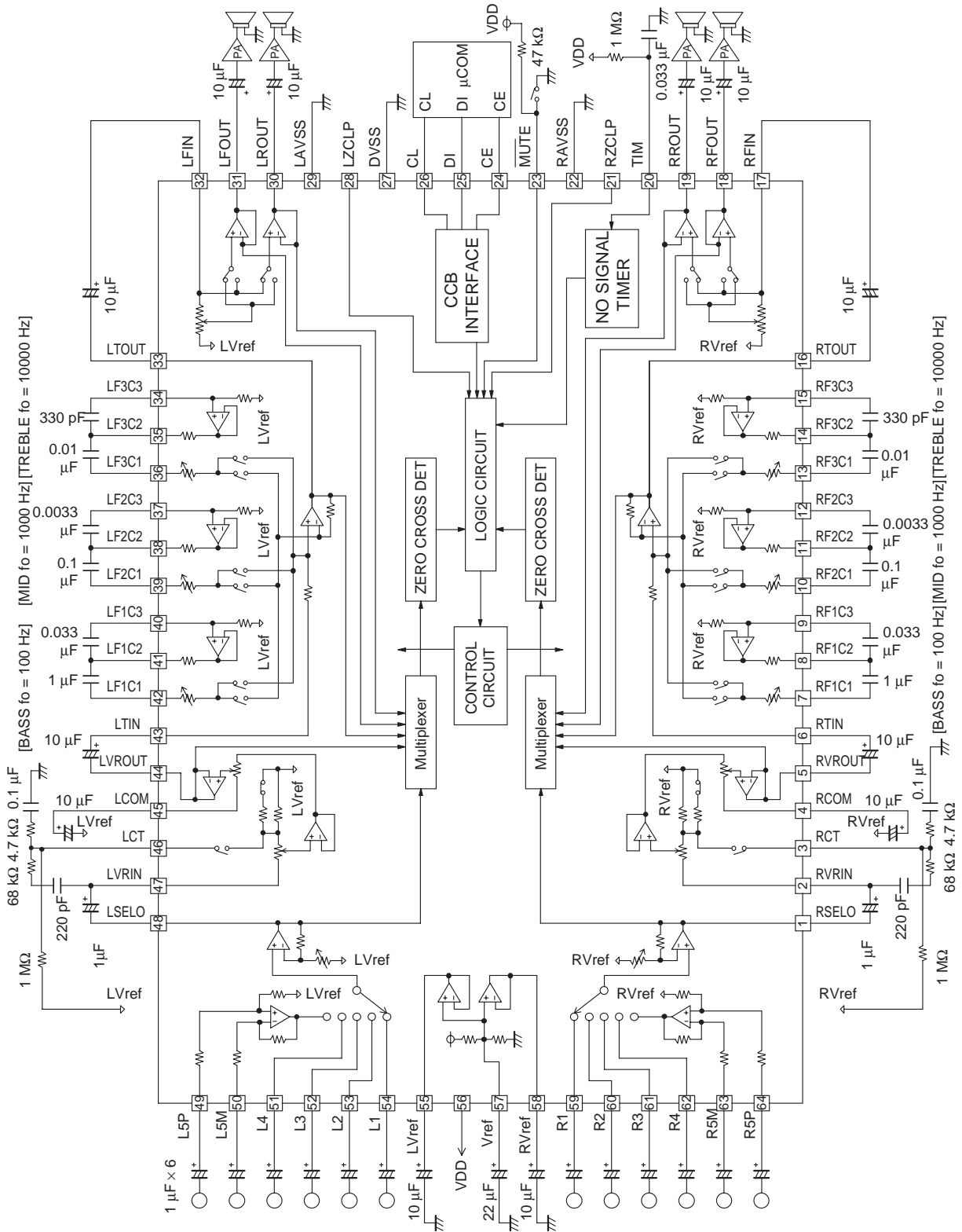

• In the LC75384NW version, LZCLP (pin 28) and RZCLP (pin 21) are unused, and must be left open.

Pin Functions

| Pin No. | Pin | Function | Notes |
|--|--|--|---|
| 54 53 52 51 59 60 61 62 | L1 L2 L3 L4 R1 R2 R3 R4 | • Single end inputs | <p>Diagram showing an operational amplifier with a non-inverting input (+) and an inverting input (-). The non-inverting input is connected to a network of resistors and diodes. One diode is connected to V_{DD} and another to ground. The inverting input is connected to a resistor network. The output is connected to a load. Labels include V_{DD}, LVref, and RVref.</p> |
| 50 49 63 64 | L5M L5P R5M R5P | • Differential inputs | <p>Diagram showing an operational amplifier with a differential input configuration. Two inputs, M and P, are connected to the op-amp through resistors and diodes. The inputs are also connected to V_{DD} and ground through diodes. Labels include V_{DD}, LVref, and RVref.</p> |
| 48 1 | LSELO RSELO | • Input selector outputs | <p>Diagram showing an operational amplifier with a feedback loop containing a diode and a resistor. The output is connected to a load. Labels include V_{DD}, LVref, and RVref.</p> |
| 47 2 | LVRIN RVRIN | • Inputs for the 2-dB step volume control • These inputs must be driven from low-impedance circuits. | <p>Diagram showing an operational amplifier with a feedback loop containing a diode and a resistor. The output is connected to a load. Labels include V_{DD}, LVref, and RVref.</p> |
| 46 3 | LCT RCT | • Loudness function pins. Connect the high-band compensation RC circuits between the LCT (RCT) and the LVRIN (RVRIN) pins and connect the low-band compensation RC circuits between the LCT (RCT) and LVREF (RVREF). | <p>Diagram showing a diode connected to V_{DD} and a resistor connected to ground. Labels include V_{DD}.</p> |
| 45 4 | LCOM RCOM | • 2-dB step volume control outputs • To reduce switching noise, each of these pins should be connected to LVREF (RVREF) through a capacitor. | <p>Diagram showing a diode connected to V_{DD} and a resistor connected to ground. Labels include V_{DD}.</p> |
| 44 5 | LVROUT RVROUT | • Output from the 1-dB step volume control | <p>Diagram showing an operational amplifier with a feedback loop containing a diode and a resistor. The output is connected to a load. Labels include V_{DD}, LVref, and RVref.</p> |

Continued on next page.

LC75384NE-R, 75384NW

Continued from preceding page.

| Pin No. | Pin | Function | Equivalent circuit |
|----------------------------------|--|--|--------------------|
| 43 6 | LTIN RTIN | <ul style="list-style-type: none"> Equalizer input | |
| 42 41 40 7 8 9 | LF1C1 LF1C2 LF1C3 RF1C1 RF1C2 RF1C3 | <ul style="list-style-type: none"> Connections for the capacitors for the equalizer's F1 band filter. The low band compensation capacitors must be connected between the following pins: LF1C1 (RF1C1) and LF1C2 (RF1C2) LF1C2 (RF1C2) and LF1C3 (RF1C3) | |
| 39 38 37 10 11 12 | LF2C1 LF2C2 LF2C3 RF2C1 RF2C2 RF2C3 | <ul style="list-style-type: none"> Connections for the capacitors for the equalizer's F2 band filter. The low band compensation capacitors must be connected between the following pins: LF2C1 (RF2C1) and LF2C2 (RF2C2) LF2C2 (RF2C2) and LF2C3 (RF2C3) | |
| 36 35 34 13 14 15 | LF3C1 LF3C2 LF3C3 RF3C1 RF3C2 RF3C3 | <ul style="list-style-type: none"> Connections for the capacitors for the equalizer's F3 band filter. The low band compensation capacitors must be connected between the following pins: LF3C1 (RF3C1) and LF3C2 (RF3C2) LF3C2 (RF3C2) and LF3C3 (RF3C3) | |
| 33 16 | LTOUT RTOUT | <ul style="list-style-type: none"> Equalizer output | |
| 32 17 | LFIN RFIN | <ul style="list-style-type: none"> Fader block inputs These inputs must be driven from low-impedance circuits. | |
| 31 30 18 19 | LFOUT LROUT RFOUT RROUT | <ul style="list-style-type: none"> Fader block outputs. The front and rear outputs can be attenuated independently. The attenuation is the same in the left and right channels. | |
| 57 | Vref | <ul style="list-style-type: none"> $V_{DD}/2$ voltage generator block. A capacitor with a value of about 10 μF must be inserted between Vref and AV_{SS} (V_{SS}) to reduce power supply ripple. | |
| 55 58 | LVref RVref | <ul style="list-style-type: none"> Internal analog system ground These pins must be handled as shown in the sample application circuit. | |

Continued on next page.

LC75384NE-R, 75384NW

Continued from preceding page.

| Pin No. | Pin | Function | Equivalent circuit |
|----------|--|---|--------------------|
| 56 | V _{DD} | • Power supply | |
| 27 | DV _{SS} | • Logic system ground | |
| 29 22 | LAV _{SS} RAV _{SS} | • Analog system ground | |
| 28 21 | LZCLP RZCLP | <ul style="list-style-type: none"> • Band limiting for the zero cross detection circuit • These pins are normally left open. • These pins are unused in the LC75384NW version and must be left open. | <p>LC75384NE-R</p> |
| 23 | $\overline{\text{MUTE}}$ | <ul style="list-style-type: none"> • External muting control • When this pin is set to the V_{SS} level, the fader volume block is forcibly set to $-\infty$. | |
| 20 | TIM | <ul style="list-style-type: none"> • Used for the zero cross circuit no-signal timer function. If a zero cross signal does not occur between the point when data is loaded and the point when the timer times out, the data will be stored forcibly when the timer times out. | |
| 26 25 | CL DI | • Serial data and clock inputs used for device control | |
| 24 | CE | <ul style="list-style-type: none"> • Chip enable input. Data is written to the internal latch when this pin goes from high to low. The analog switches then operate. Data transfers are enabled when this pin is high. | |

Internal Equivalent Circuits

Selector Block Equivalent Circuit

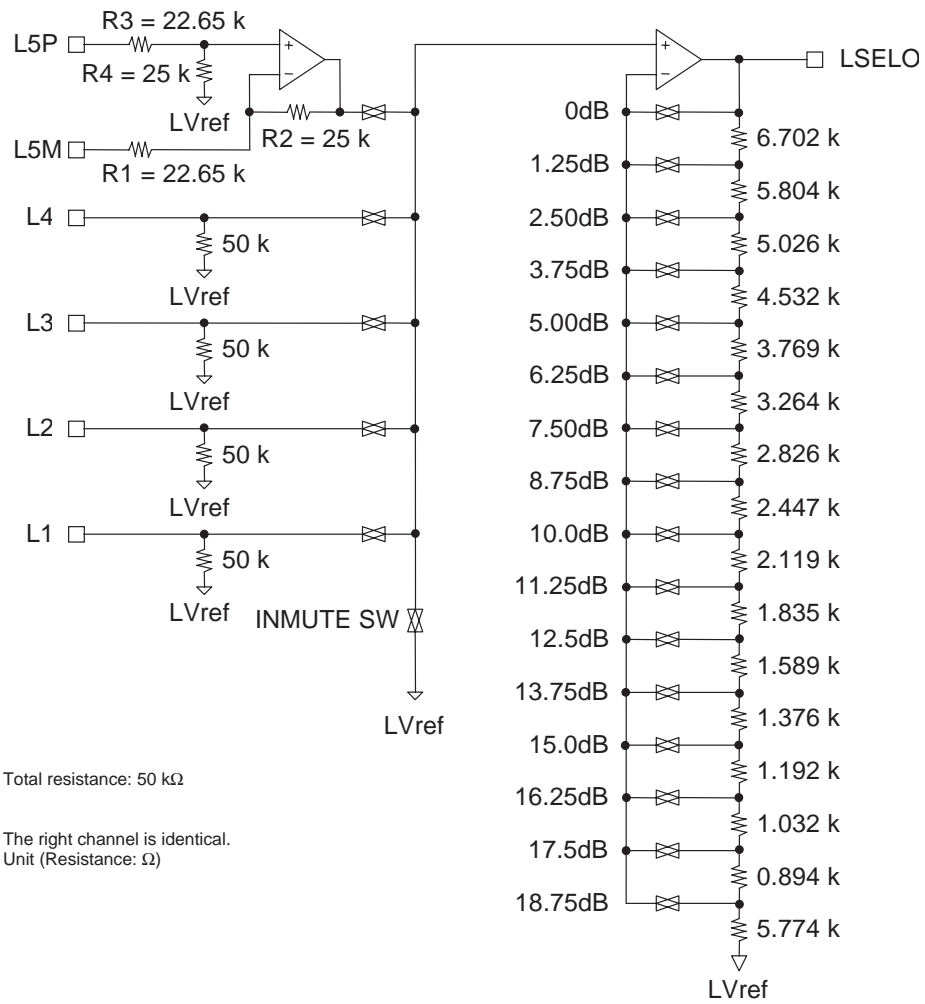

LC75384NE-R, 75384NW

2-dB Step Volume Control Block Equivalent Circuit

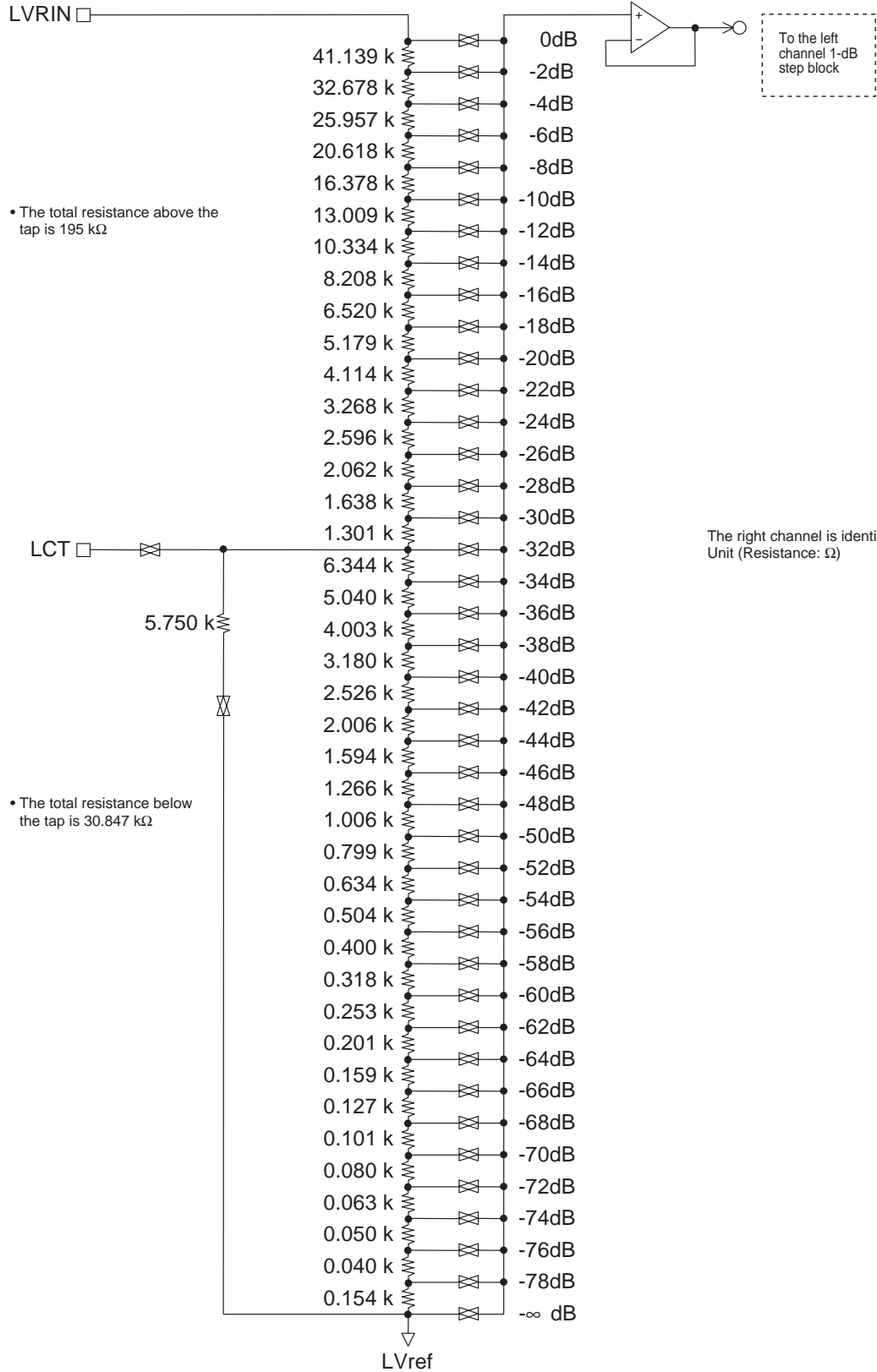

LC75384NE-R, 75384NW

1-dB Step Volume Control Block Equivalent Circuit

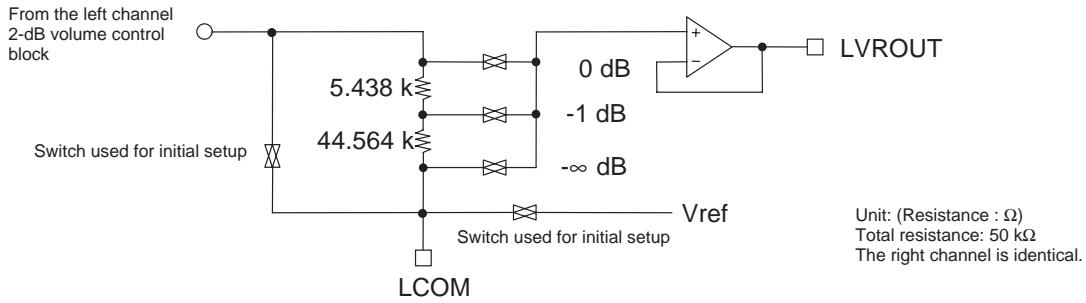

Three-Band Graphic Equalizer Block Equivalent Circuit Diagram

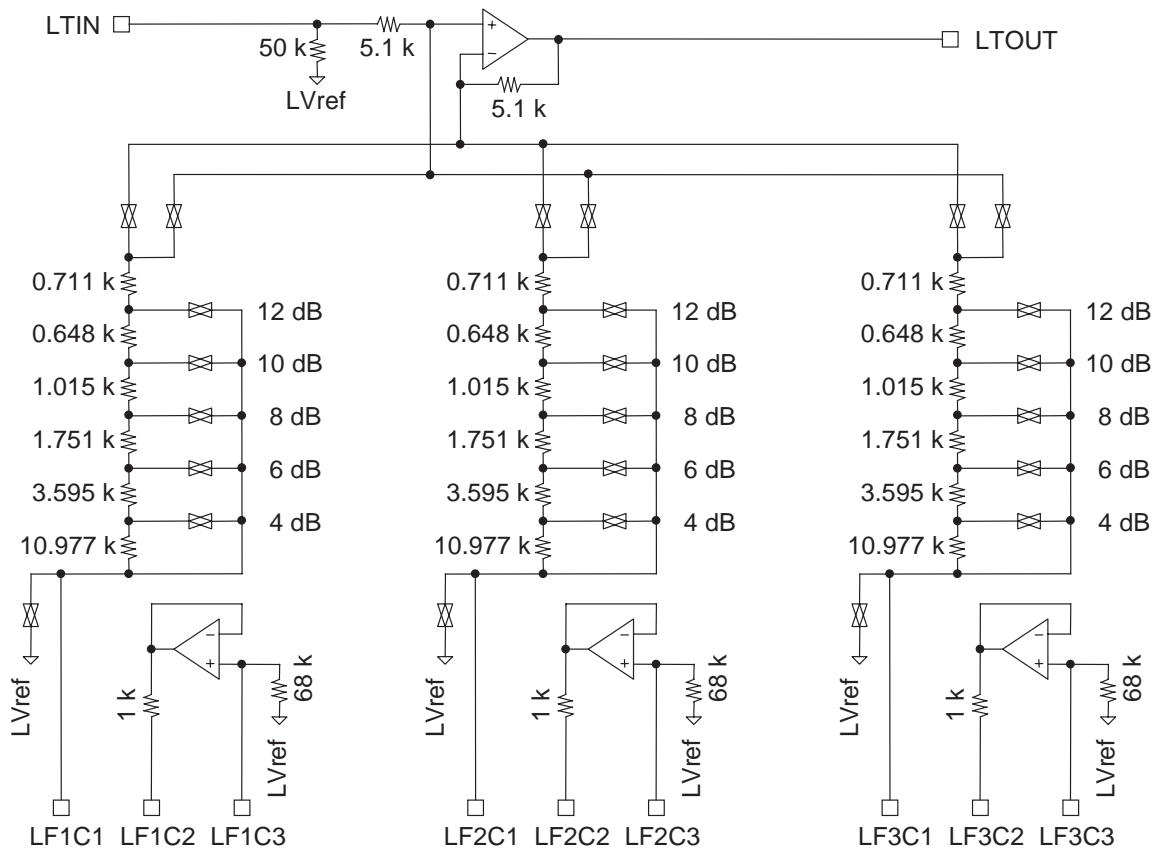

LC75384NE-R, 75384NW

The external capacitors C1 and C2 used with the LC75384W form the structural element of the simulated inductor implemented by the IC. This section present the equivalent circuit and the method for calculating the constants required to obtain the desired center frequency.

(A) Simulated inductor equivalent circuit

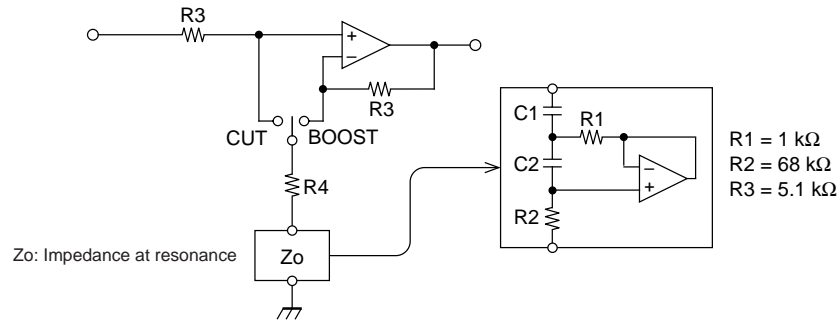

(B) Calculation

- Specifications:
1. Center frequency: $F_0 = 100 \text{ Hz}$
 2. Q at maximum boost: $Q_{+12\text{dB}} = 0.9$

1. Determine the sharpness, Q_0 , of the simulated inductor itself.

$$Q_0 = \frac{(R1 + R4)}{R1} \times Q_{+12\text{dB}} \approx 1.5399$$

2. Determine C1.

$$C1 = 1/2\pi F_0 R1 Q_0 \approx 1 \text{ (}\mu\text{F)}$$

3. Determine C2.

$$C2 = Q_0/2\pi F_0 R2 \approx 0.036 \text{ (}\mu\text{F)}$$

Note: * See the equivalent circuit diagram for the tone control block on page 11 for details on the internal resistor.

LC75384NE-R, 75384NW

Fader Volume Control Block Equivalent Circuit

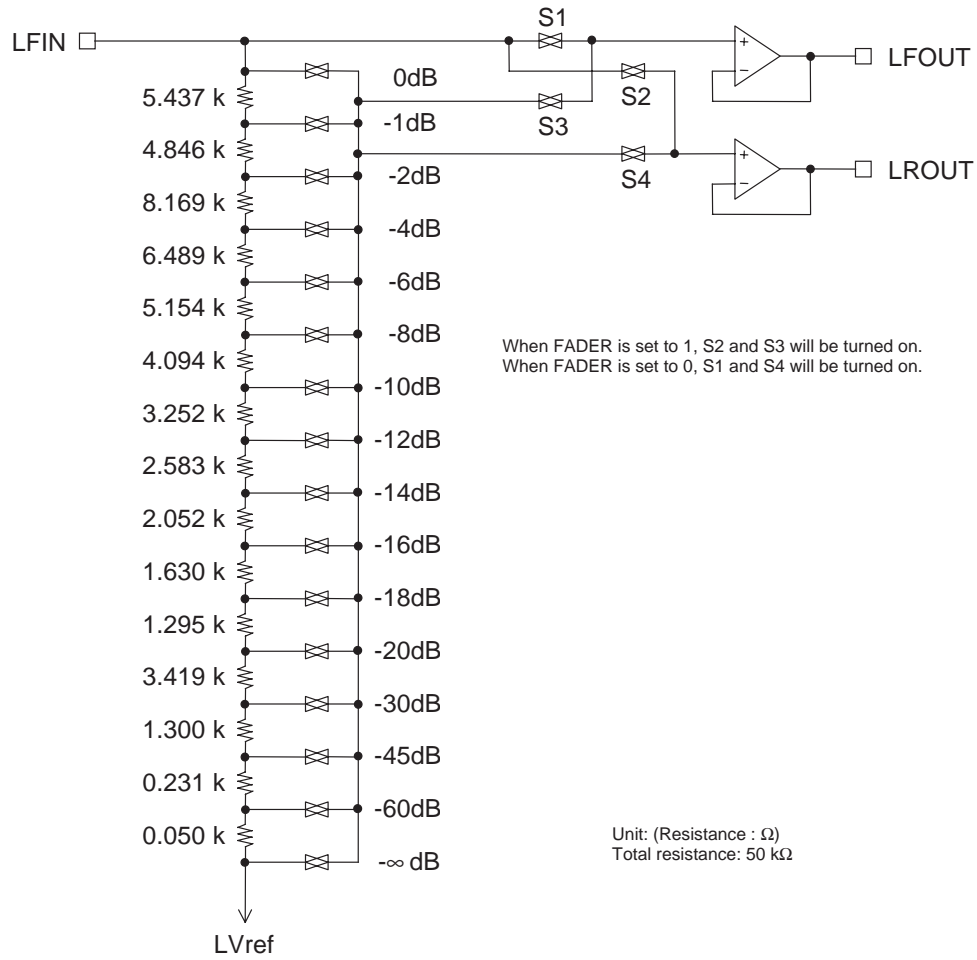

If data that sets the main volume control 1-dB step circuit to $-\infty$ is sent to the device, switches S1 and S2 will be opened (off) and switches S3 and S4 will be closed (on).

Control System Timing and Data Format

The LC75384NE-R/NW are controlled by applying the stipulated data to the CL, DI, and CE pins. The data consists of a total of 52 bits, of which 8 bits are the device address and 44 bits are the actual control data.

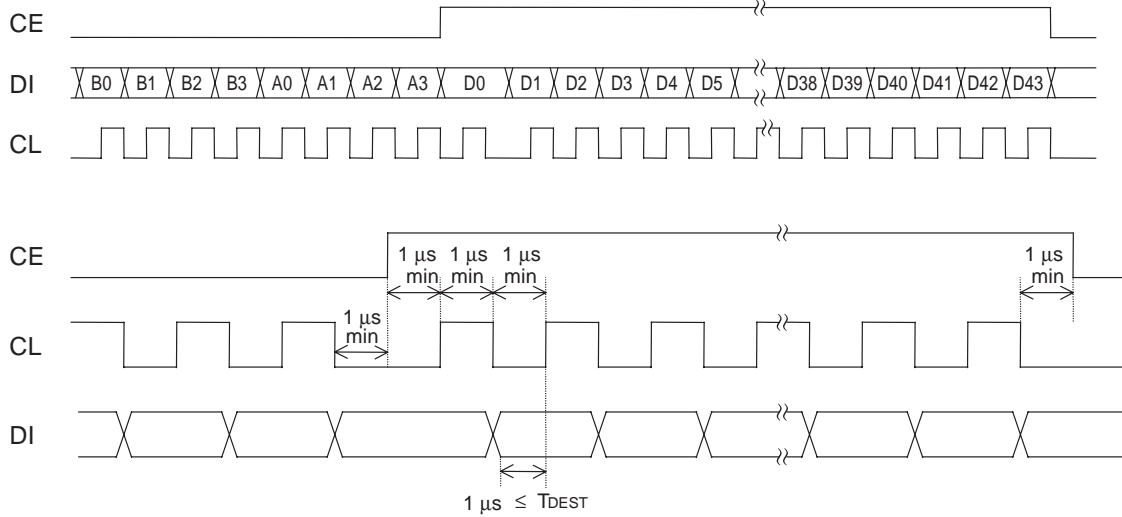

• Address code (B0 to A3)

The LC75384NE-R/NW have an 8-bit address codes, and can be used along with other ICs that support the Sanyo CCB serial bus.

Address code

| | | | | | | | | | |
|-------|----|----|----|----|----|----|----|----|---------|
| (LSB) | B0 | B1 | B2 | B3 | A0 | A1 | A2 | A3 | (81HEX) |
| | 1 | 0 | 0 | 0 | 0 | 0 | 0 | 1 | |

• Control code allocation

Input switching control

| D0 | D1 | D2 | Setting |
|----|----|----|--|
| 0 | 0 | 0 | L1 (R1) |
| 1 | 0 | 0 | L2 (R2) |
| 0 | 1 | 0 | L3 (R3) |
| 1 | 1 | 0 | L4 (R4) |
| 0 | 0 | 1 | L5 (R5) |
| 0 | 1 | 1 | IC test values. These values must not be used during normal operation. |
| 1 | 1 | 1 | |

| | |
|----|---|
| D3 | IC test bit. This bit must be set to 0 during normal operation. |
|----|---|

Input gain control

| D4 | D5 | D6 | D7 | Operation |
|----|----|----|----|-----------|
| 0 | 0 | 0 | 0 | 0 dB |
| 1 | 0 | 0 | 0 | +1.25 dB |
| 0 | 1 | 0 | 0 | +2.50 dB |
| 1 | 1 | 0 | 0 | +3.75 dB |
| 0 | 0 | 1 | 0 | +5.00 dB |
| 1 | 0 | 1 | 0 | +6.25 dB |
| 0 | 1 | 1 | 0 | +7.50 dB |
| 1 | 1 | 1 | 0 | +8.75 dB |
| 0 | 0 | 0 | 1 | +10.0 dB |
| 1 | 0 | 0 | 1 | +11.25 dB |
| 0 | 1 | 0 | 1 | +12.5 dB |
| 1 | 1 | 0 | 1 | +13.75 dB |
| 0 | 0 | 1 | 1 | +15.0 dB |
| 1 | 0 | 1 | 1 | +16.25 dB |
| 0 | 1 | 1 | 1 | +17.5 dB |
| 1 | 1 | 1 | 1 | +18.75 dB |

LC75384NE-R, 75384NW

Volume Control

| D8 | D9 | D10 | D11 | D12 | D13 | D14 | D15 | Operation |
|----|----|-----|-----|-----|-----|-----|-----|-----------|
| | | | | | | | | 1-dB step |
| 0 | | | | | | | | 0 dB |
| 1 | | | | | | | | -1 dB |
| | | | | | | | | 2-dB step |
| | 0 | 0 | 0 | 0 | 0 | 0 | 0 | 0 dB |
| | 1 | 0 | 0 | 0 | 0 | 0 | 0 | -2 dB |
| | 0 | 1 | 0 | 0 | 0 | 0 | 0 | -4 dB |
| | 1 | 1 | 0 | 0 | 0 | 0 | 0 | -6 dB |
| | 0 | 0 | 1 | 0 | 0 | 0 | 0 | -8 dB |
| | 1 | 0 | 1 | 0 | 0 | 0 | 0 | -10 dB |
| | 0 | 1 | 1 | 0 | 0 | 0 | 0 | -12 dB |
| | 1 | 1 | 1 | 0 | 0 | 0 | 0 | -14 dB |
| | 0 | 0 | 0 | 1 | 0 | 0 | 0 | -16 dB |
| | 1 | 0 | 0 | 1 | 0 | 0 | 0 | -18 dB |
| | 0 | 1 | 0 | 1 | 0 | 0 | 0 | -20 dB |
| | 1 | 1 | 0 | 1 | 0 | 0 | 0 | -22 dB |
| | 0 | 0 | 1 | 1 | 0 | 0 | 0 | -24 dB |
| | 1 | 0 | 1 | 1 | 0 | 0 | 0 | -26 dB |
| | 0 | 1 | 1 | 1 | 0 | 0 | 0 | -28 dB |
| | 1 | 1 | 1 | 1 | 0 | 0 | 0 | -30 dB |
| | 0 | 0 | 0 | 0 | 1 | 0 | 0 | -32 dB |
| | 1 | 0 | 0 | 0 | 1 | 0 | 0 | -34 dB |
| | 0 | 1 | 0 | 0 | 1 | 0 | 0 | -36 dB |
| | 1 | 1 | 0 | 0 | 1 | 0 | 0 | -38 dB |
| | 0 | 0 | 1 | 0 | 1 | 0 | 0 | -40 dB |
| | 1 | 0 | 1 | 0 | 1 | 0 | 0 | -42 dB |
| | 0 | 1 | 1 | 0 | 1 | 0 | 0 | -44 dB |
| | 1 | 1 | 1 | 0 | 1 | 0 | 0 | -46 dB |
| | 0 | 0 | 0 | 1 | 1 | 0 | 0 | -48 dB |
| | 1 | 0 | 0 | 1 | 1 | 0 | 0 | -50 dB |
| | 0 | 1 | 0 | 1 | 1 | 0 | 0 | -52 dB |
| | 1 | 1 | 0 | 1 | 1 | 0 | 0 | -54 dB |
| | 0 | 0 | 1 | 1 | 1 | 0 | 0 | -56 dB |
| | 1 | 0 | 1 | 1 | 1 | 0 | 0 | -58 dB |
| | 0 | 1 | 1 | 1 | 1 | 0 | 0 | -60 dB |
| | 1 | 1 | 1 | 1 | 1 | 0 | 0 | -62 dB |
| | 0 | 0 | 0 | 0 | 0 | 1 | 0 | -64 dB |
| | 1 | 0 | 0 | 0 | 0 | 1 | 0 | -66 dB |
| | 0 | 1 | 0 | 0 | 0 | 1 | 0 | -68 dB |
| | 1 | 1 | 0 | 0 | 0 | 1 | 0 | -70 dB |
| | 0 | 0 | 1 | 0 | 0 | 1 | 0 | -72 dB |
| | 1 | 0 | 1 | 0 | 0 | 1 | 0 | -74 dB |
| | 0 | 1 | 1 | 0 | 0 | 1 | 0 | -76 dB |
| | 1 | 1 | 1 | 0 | 0 | 1 | 0 | -78 dB |
| | | | | | | | | Mute |
| | 1 | 1 | 1 | 1 | 1 | 1 | 0 | -∞ |

Three-band equalizer control

| D16 | D17 | D18 | D19 | f1 band |
|-----|-----|-----|-----|---------|
| D20 | D21 | D22 | D23 | f2 band |
| D24 | D25 | D26 | D27 | f3 band |
| 0 | 1 | 1 | 0 | +12 dB |
| 1 | 0 | 1 | 0 | +10 dB |
| 0 | 0 | 1 | 0 | +8 dB |
| 1 | 1 | 0 | 0 | +6 dB |
| 0 | 1 | 0 | 0 | +4 dB |
| 1 | 0 | 0 | 0 | +2 dB |
| 0 | 0 | 0 | 0 | 0 dB |
| 1 | 0 | 0 | 1 | -2 dB |
| 0 | 1 | 0 | 1 | -4 dB |
| 1 | 1 | 0 | 1 | -6 dB |
| 0 | 0 | 1 | 1 | -8 dB |
| 1 | 0 | 1 | 1 | -10 dB |
| 0 | 1 | 1 | 1 | -12 dB |

Fader Volume Control

| D28 | D29 | D30 | D31 | Operation |
|-----|-----|-----|-----|-----------|
| 0 | 0 | 0 | 0 | 0 dB |
| 1 | 0 | 0 | 0 | -1 dB |
| 0 | 1 | 0 | 0 | -2 dB |
| 1 | 1 | 0 | 0 | -4 dB |
| 0 | 0 | 1 | 0 | -6 dB |
| 1 | 0 | 1 | 0 | -8 dB |
| 0 | 1 | 1 | 0 | -10 dB |
| 1 | 1 | 1 | 0 | -12 dB |
| 0 | 0 | 0 | 1 | -14 dB |
| 1 | 0 | 0 | 1 | -16 dB |
| 0 | 1 | 0 | 1 | -18 dB |
| 1 | 1 | 0 | 1 | -20 dB |
| 0 | 0 | 1 | 1 | -30 dB |
| 1 | 0 | 1 | 1 | -45 dB |
| 0 | 1 | 1 | 1 | -60 dB |
| 1 | 1 | 1 | 1 | -∞ |

Channel Selection Control

| D32 | D33 | Setting |
|-----|-----|--|
| 0 | 0 | Left and right together. This is the mode set up initially |
| 1 | 0 | RCH |
| 0 | 1 | LCH |
| 1 | 1 | Left and right together |

Fader Rear/Front Control

| D34 | Setting |
|-----|---------|
| 0 | Rear |
| 1 | Front |

Loudness Control

| D35 | Setting |
|-----|---------|
| 0 | Off |
| 1 | On |

Zero Cross Control

| D36 | D37 | Setting |
|-----|-----|---|
| 0 | 0 | Data is written when a zero cross is detected |
| 1 | 1 | The zero cross detection operation is disabled and data is written on the falling edge of the CE signal |

Zero Cross Signal Detection Block Control

| D38 | D39 | D40 | D41 | Setting |
|-----|-----|-----|-----|----------|
| 0 | 0 | 0 | 0 | Selector |
| 1 | 0 | 0 | 0 | Volume |
| 0 | 1 | 0 | 0 | Tone |
| 1 | 1 | 0 | 0 | Fader |

Test Mode Control

| D42 | D43 | Setting |
|-----|-----|--|
| 0 | 0 | These IC test mode control bits must be set to 0 |

Usage Notes

Data Transmission after Power Is First Applied

- When power is first applied, the state of the internal analog switches will be undefined. Applications that use this IC must include external circuits to provide muting until control data has been transferred to the IC.
- After power is first applied, applications should send initial setup data to stabilize the bias levels in each of the IC circuit blocks in a short time.

1. The time between initial setup mode and the first actual data settings

- Applications should send the initial setup data as soon as V_{DD} rises above 6 V.
- After the LCOM and RCOM pins have stabilized at the V_{ref} level, applications should set the initial data.

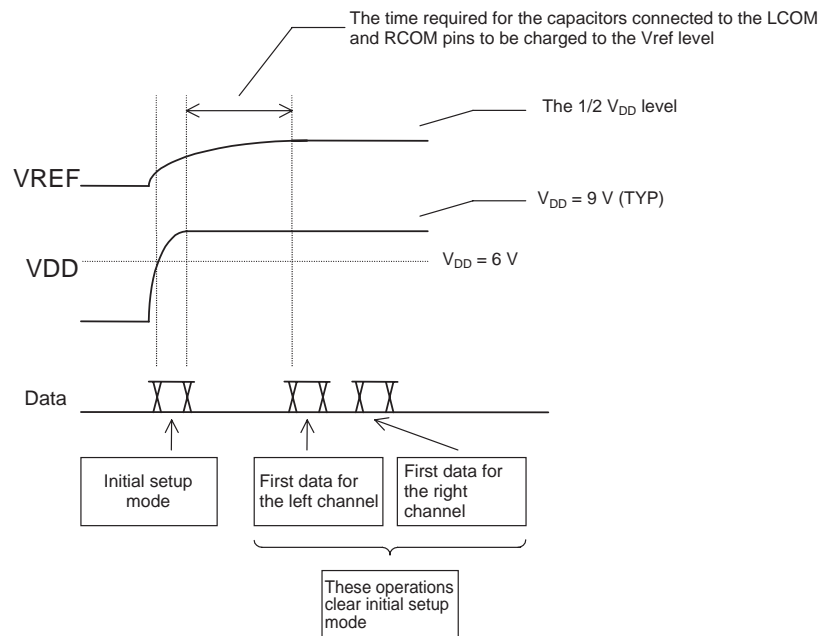

2. Procedure for setting up initial setup mode

- When D32 and D33 are set to 00, the IC's internal initial setup switch is turned on and the IC goes to quick charge mode. At this time the other data (D0 to D31 and D34 to D43) will also be set up for the left and right channels at the same time. This means that applications can set up the states of the various blocks at the same time as specifying initial setup mode.

3. Procedure for clearing initial setup mode

- Initial setup mode is cleared by setting D32 and D33 to any value other than 00. In other words, any normal left or right channel specification will turn the internal initial setup switch off and clear quick charge mode.

Zero Cross Switching Circuit Operating Principles

- The LC75384NE-R/NW include functions for switching the place where the zero cross comparator operates and thus allows applications to select the optimal detection location for the block for which the control data is updated. Basically, switching noise will be minimized if the signal immediately following the block for which the control data is updated is input to the zero cross comparator. Thus the detection location must be changed for each data update operation. Another issue is the point that if the signal amplitude is lower than the detection sensitivity (a few mV rms) of the zero cross comparator (for example if the volume is set to a low level), the switching noise can be minimized further by selecting a point before the volume control block, namely the selector block output, as the zero cross detection point than by simply waiting for the data write to occur due to the overflow of the zero cross timer. For example, if the volume block input is 1 V rms, and the volume is set to -40 dB or lower, the output will be under 10 mV rms. In this case, detecting at the selector output block will result in lower switching noise.

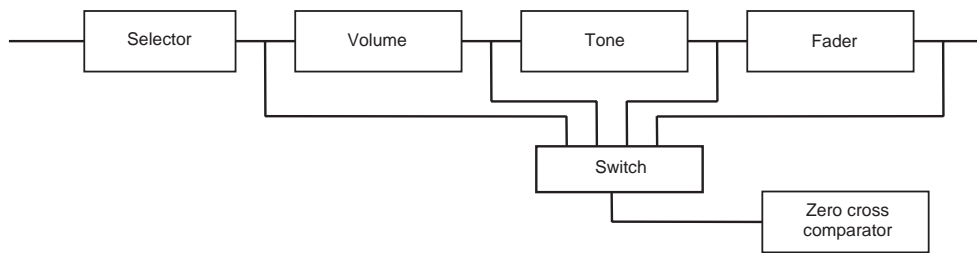

Zero Cross Detection Circuit

Zero Cross Switching Control Procedure

- The zero cross switching control procedure consists of first setting the zero cross detection mode with the zero cross control bits (D36 and D37 = 0) and then, after specifying the detection block (with bits D38, D39, D40, and D41), sending the control data. Since these control bits are latched first immediately after the data is sent, i.e. on the falling edge of the CE signal, it is possible to both set the IC mode as well as specify zero cross switching operation in a single data transfer, even when updating the volume and other data. The following presents an example of the control operation when updating the volume block data.

| D36 | D37 | D38 | D39 | D40 | D41 |
|-----|-----|-----|-----|-----|-----|
| 0 | 0 | 1 | 0 | 0 | 0 |

Zero cross detection mode specification
Volume block setting

Zero Cross Timer Setting

- When the input signal has a level lower than the detecting sensitivity of the zero cross comparator, or consists only of extremely low frequencies, the zero cross detection circuit will remain in the state in which it cannot detect a zero cross and the data will not be latched during that period. The zero cross timer specifies a time after which the data will be latched forcibly in states where a zero crossing cannot be detected. The time is determined by the lowest frequency for which a zero cross can be detected reliably.

For example, if the timer is set to 25 ms:

$$T = 0.69 CR$$

If C is taken to be 0.033 μF, then R will be:

$$R = \frac{25 \times 10^{-3}}{0.69 \times 0.033 \times 10^{-6}} \approx 1.1 \text{ M}\Omega$$

LC75384NE-R, 75384NW

Notes on Serial Data Transfer

1. The CL, DI, and CE pin signal lines must be covered (and thus shielded) by the ground pattern or formed from shielded cable to prevent the high-frequency digital signals on those lines from entering the analog system.
2. The LC75384NE-R/NW data formats consist of 8 bits of address and 44 bits of data. When the data is sent in units of 8 bits each (i.e. 48 bits are actually sent), use the data transfer technique shown in figure 1.

LC75384NE-R/NW data receptions in 8-bit units

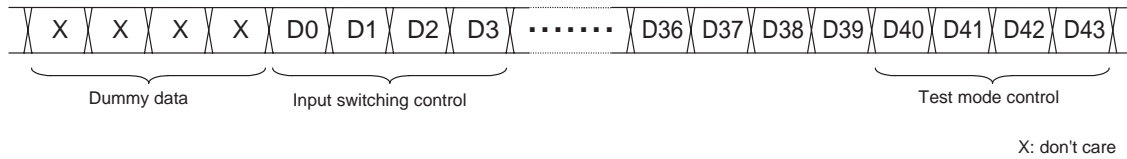

3. During CCB transfers, this IC detects address matches on the rising edge of the CE signal. Therefore, applications must set the CL signal low and then set it high at this time.

Output Level Characteristics

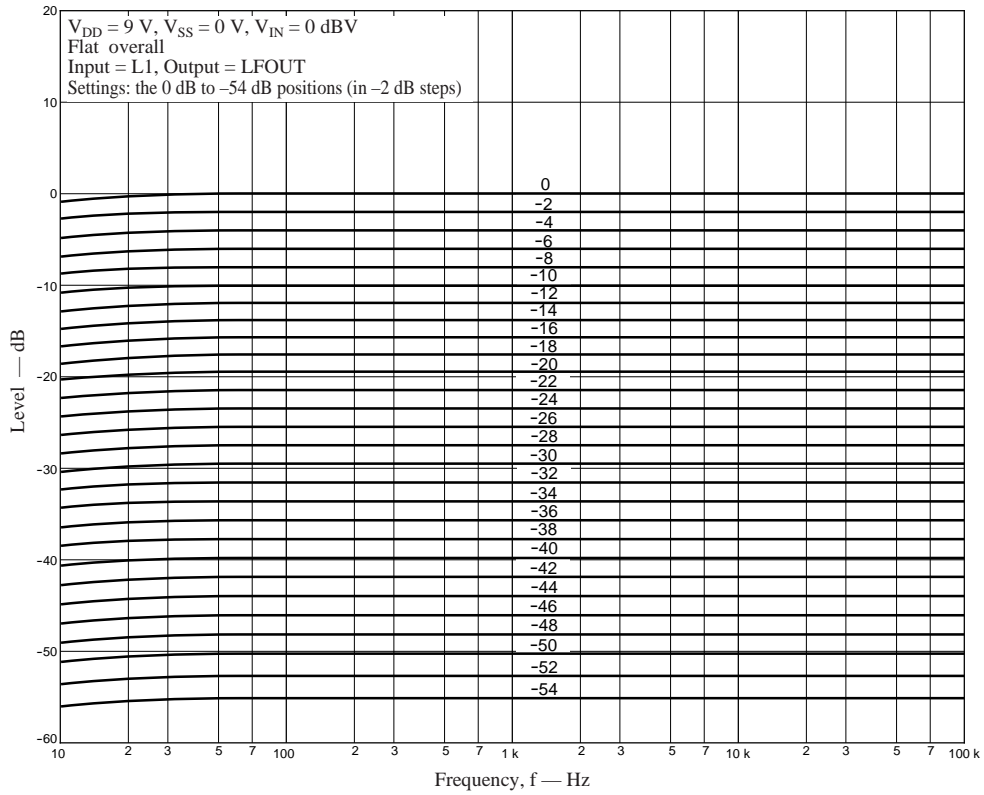

Loudness Characteristics

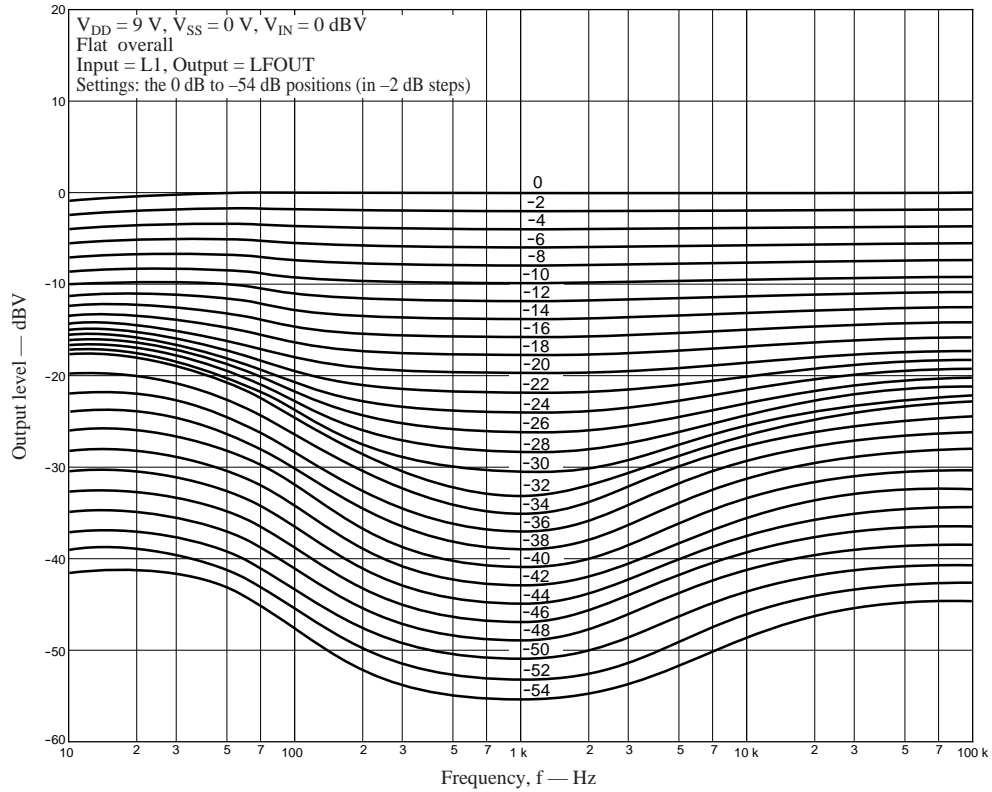

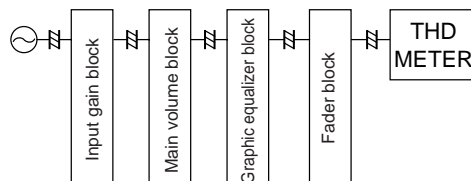
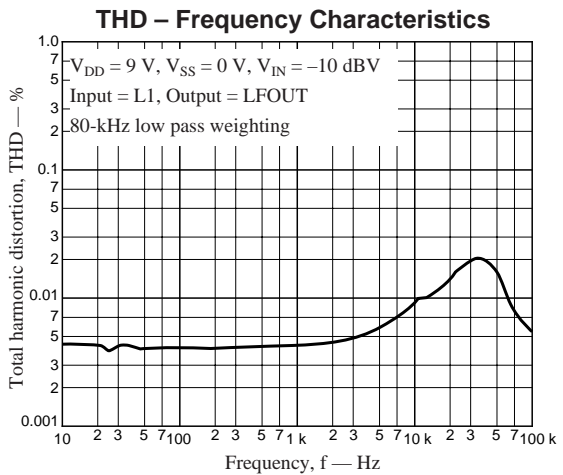
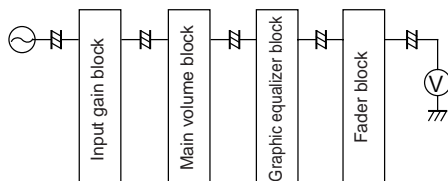
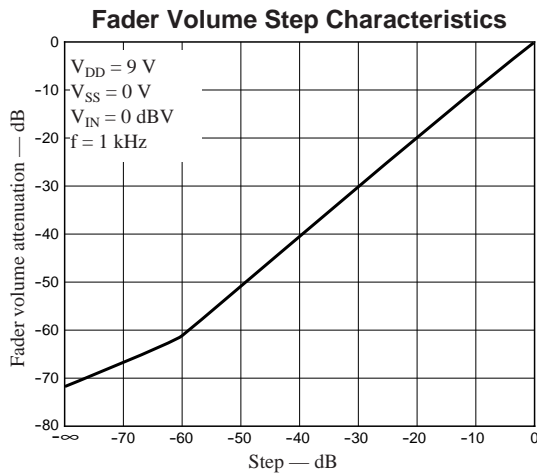
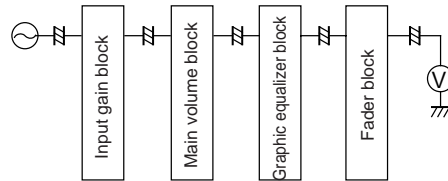
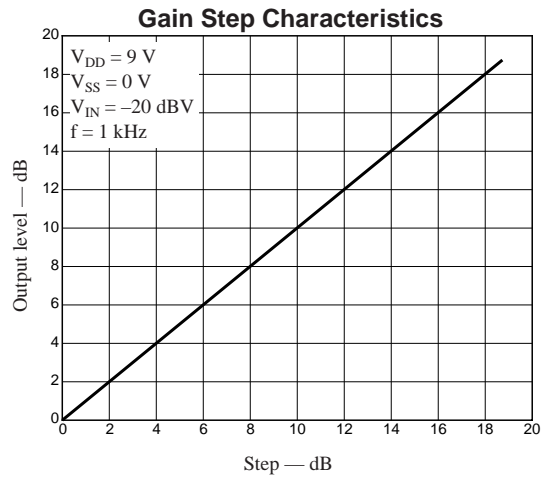
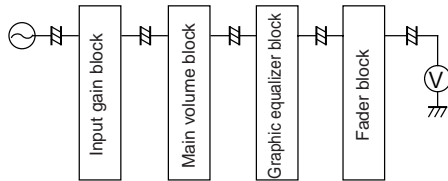
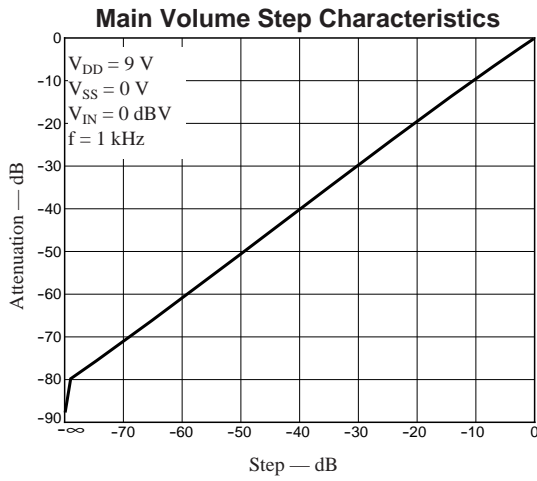

THD – Input Level Characteristics

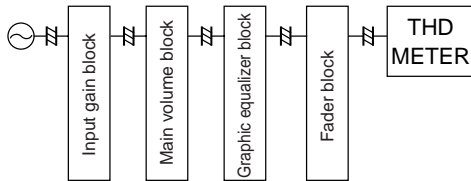
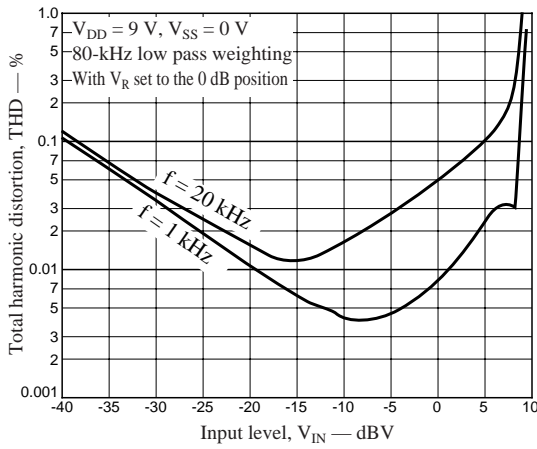

THD – Supply Voltage Characteristics

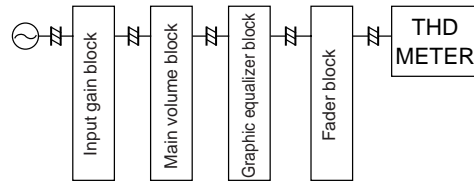
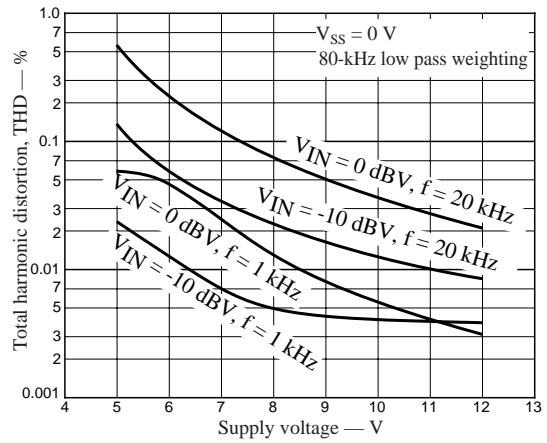

F1 Band Characteristics

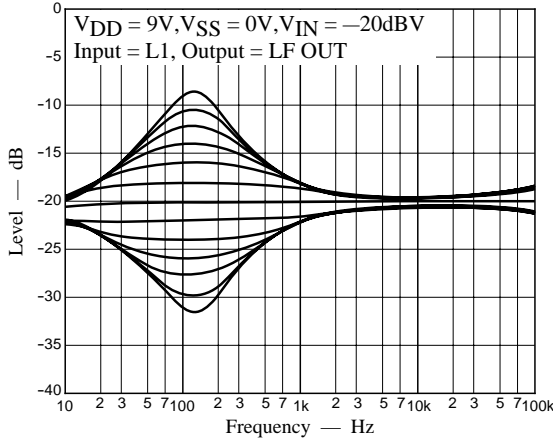

F2 Band Characteristics

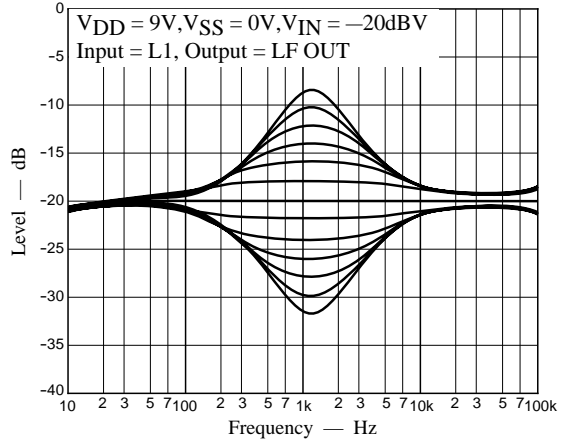

F3 Band characteristics

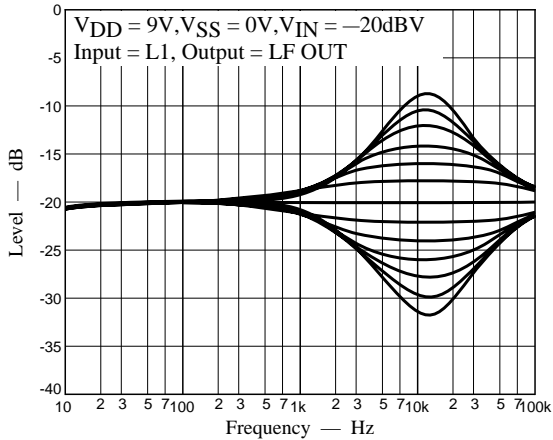

- Specifications of any and all SANYO products described or contained herein stipulate the performance, characteristics, and functions of the described products in the independent state, and are not guarantees of the performance, characteristics, and functions of the described products as mounted in the customer's products or equipment. To verify symptoms and states that cannot be evaluated in an independent device, the customer should always evaluate and test devices mounted in the customer's products or equipment.
- SANYO Electric Co., Ltd. strives to supply high-quality high-reliability products. However, any and all semiconductor products fail with some probability. It is possible that these probabilistic failures could give rise to accidents or events that could endanger human lives, that could give rise to smoke or fire, or that could cause damage to other property. When designing equipment, adopt safety measures so that these kinds of accidents or events cannot occur. Such measures include but are not limited to protective circuits and error prevention circuits for safe design, redundant design, and structural design.
- In the event that any or all SANYO products (including technical data, services) described or contained herein are controlled under any of applicable local export control laws and regulations, such products must not be exported without obtaining the export license from the authorities concerned in accordance with the above law.
- No part of this publication may be reproduced or transmitted in any form or by any means, electronic or mechanical, including photocopying and recording, or any information storage or retrieval system, or otherwise, without the prior written permission of SANYO Electric Co., Ltd.
- Any and all information described or contained herein are subject to change without notice due to product/technology improvement, etc. When designing equipment, refer to the "Delivery Specification" for the SANYO product that you intend to use.
- Information (including circuit diagrams and circuit parameters) herein is for example only; it is not guaranteed for volume production. SANYO believes information herein is accurate and reliable, but no guarantees are made or implied regarding its use or any infringements of intellectual property rights or other rights of third parties.

This catalog provides information as of May, 2000. Specifications and information herein are subject to change without notice.