



# SANYO Semiconductors DATA SHEET

## LC75873NE — CMOS LSI LC75873NW — 1/3-Duty General-Purpose LCD Display Driver

### Overview

The LC75873NE and LC75873NW are 1/3-duty general-purpose microprocessor-controlled LCD driver that can be used in applications such as frequency display in products with electronic tuning. In addition to being able to drive up to 204 segments directly, the LC75873NE and LC75873NW can also control up to 4 general-purpose output ports.

### Features

- Support for 1/3-duty 1/2-bias or 1/3-duty 1/3-bias drive techniques under serial data control (up to 204 segments)
- Serial data input supports CCB format communication with the system controller.
- Serial data control of the power-saving mode based backup function and the all segments forced off function.
- Serial data control of switching between the segment output port and general-purpose output port functions.
- High generality, since display data is displayed directly without the intervention of a decoder circuit.
- The  $\overline{\text{INH}}$  pin allows the display to be forced to the off state.
- RC oscillator circuit

- CCB is a trademark of SANYO ELECTRIC CO., LTD.
- CCB is SANYO's original bus format and all the bus addresses are controlled by SANYO.

### Package Dimensions

unit: mm

#### 3174-QFP80E

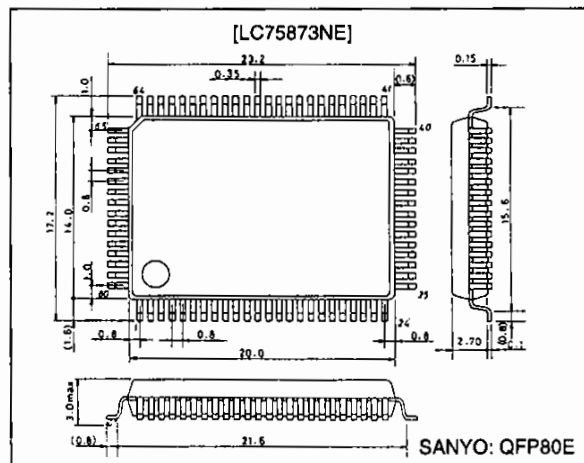

unit: mm

#### 3220-SQFP80

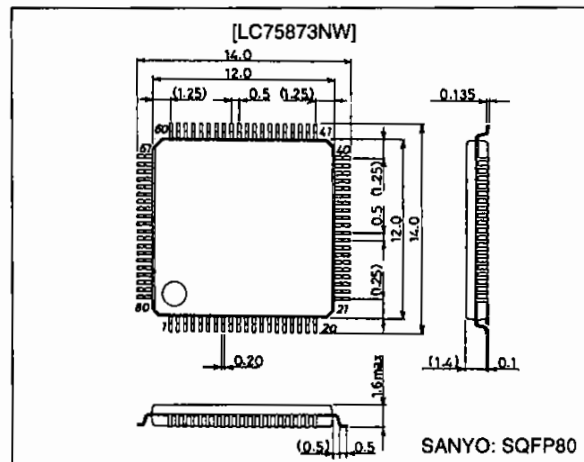

**SANYO Electric Co., Ltd. Semiconductor Company**

TOKYO OFFICE Tokyo Bldg., 1-10, 1 Chome, Ueno, Taito-ku, TOKYO, 110-8534 JAPAN

3096HA (OT) No. 5176-1/15

Pin Assignments

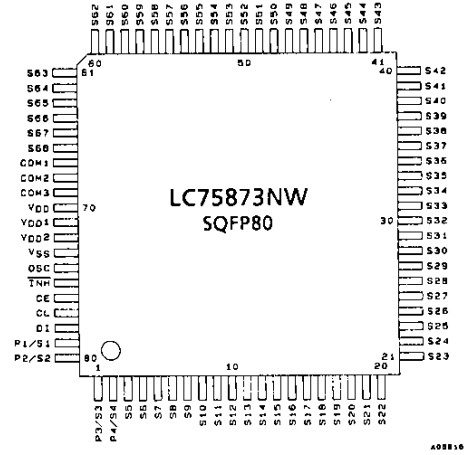
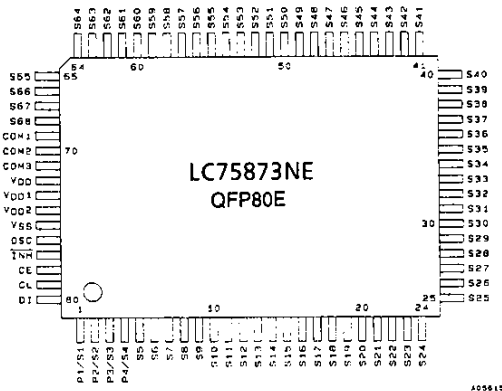

Top view

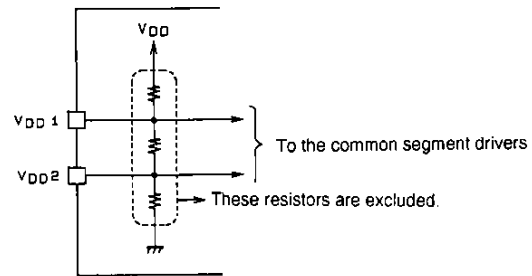

A04171

Figure 1

Specifications

Absolute Maximum Ratings at Ta = 25°C, VSS = 0 V

Parameter	Symbol	Conditions	Ratings	Unit
Maximum supply voltage	V <sub>DD max</sub>	V <sub>DD</sub>	-0.3 to +7.0	V
Input voltage	V <sub>IN1</sub>	CE, CL, DI, $\overline{INH}$	-0.3 to +7.0	V
	V <sub>IN2</sub>	OSC, V <sub>DD1</sub> , V <sub>DD2</sub>	-0.3 to V <sub>DD</sub> + 0.3	V
Output voltage	V <sub>OUT</sub>	OSC, S1 to S68, COM1 to COM3, P1 or P4	-0.3 to V <sub>DD</sub> + 0.3	V
Output current	I <sub>OUT1</sub>	S1 to S68	300	μA
	I <sub>OUT2</sub>	COM1 to COM3	3	mA
	I <sub>OUT3</sub>	P1 to P4	5	mA
Allowable power dissipation	P <sub>d max</sub>	Ta = 85°C	200	mW
Operating temperature	T <sub>opr</sub>		-40 to +85	°C
Storage temperature	T <sub>stg</sub>		-55 to +125	°C

LC75873NE, 75873NW

Allowable Operating Ranges at Ta = -40 to +85°C, VSS = 0 V

Parameter	Symbol	Conditions	min	typ	max	Unit
Supply voltage	V <sub>DD</sub>	V <sub>DD</sub>	3.0		6.0	V
Input voltage	V <sub>DD1</sub>	V <sub>DD1</sub>		2/3 V <sub>DD</sub>	V <sub>DD</sub>	V
	V <sub>DD2</sub>	V <sub>DD2</sub>		1/3 V <sub>DD</sub>	V <sub>DD</sub>	V
Input high-level voltage	V <sub>IH</sub>	CE, CL, DI, INH	0.8 V <sub>DD</sub>		6.0	V
Input low-level voltage	V <sub>IL</sub>	CE, CL, DI, INH	0		0.2 V <sub>DD</sub>	V
Recommended external resistance	R <sub>OSC</sub>	OSC		180		kΩ
Recommended external capacitance	C <sub>OSC</sub>	OSC		220		pF
Guaranteed oscillation range	f <sub>OSC</sub>	OSC	19	38	76	kHz
Data setup time	t <sub>ds</sub>	CL, DI: Figure 2	160			ns
Data hold time	t <sub>dh</sub>	CL, DI: Figure 2	160			ns
CE wait time	t <sub>cp</sub>	CE, CL: Figure 2	160			ns
CE setup time	t <sub>cs</sub>	CE, CL: Figure 2	160			ns
CE hold time	t <sub>ch</sub>	CE, CL: Figure 2	160			ns
High-level clock pulse width	t <sub>gH</sub>	CL: Figure 2	160			ns
Low-level clock pulse width	t <sub>gL</sub>	CL: Figure 2	160			ns
Rise time	t <sub>r</sub>	CE, CL, DI: Figure 2		160		ns
Fall time	t <sub>f</sub>	CE, CL, DI: Figure 2		160		ns
INH switching time	t <sub>c</sub>	INH, CE: Figure 3	10			μs

Electrical Characteristics for the Allowable Operating Ranges

Parameter	Symbol	Conditions	min	typ	max	Unit
Hysteresis	V <sub>H</sub>	CE, CL, DI, INH		0.1 V <sub>DD</sub>		V
Input high-level current	I <sub>IH</sub>	CE, CL, DI, INH: V <sub>I</sub> = 6.0 V			5.0	μA
Input low-level current	I <sub>IL</sub>	CE, CL, DI, INH: V <sub>I</sub> = 0 V	-5.0			μA
Output high-level voltage	V <sub>OH1</sub>	S1 to S68: I <sub>O</sub> = -20 μA	V <sub>DD</sub> - 1.0			V
	V <sub>OH2</sub>	COM1 to COM3: I <sub>O</sub> = -100 μA	V <sub>DD</sub> - 1.0			V
	V <sub>OH3</sub>	P1 to P4: I <sub>O</sub> = -1 mA	V <sub>DD</sub> - 1.0			V
Output low-level voltage	V <sub>OL1</sub>	S1 to S68: I <sub>O</sub> = 20 μA			1.0	V
	V <sub>OL2</sub>	COM1 to COM3: I <sub>O</sub> = 100 μA			1.0	V
	V <sub>OL3</sub>	P1 to P4: I <sub>O</sub> = 1 mA			1.0	V
Output middle-level voltage*	V <sub>MID1</sub>	COM1 to COM3: 1/2 bias, I <sub>O</sub> = ±100 μA	1/2 V <sub>DD</sub> - 1.0		1/2 V <sub>DD</sub> + 1.0	V
	V <sub>MID2</sub>	S1 to S68: 1/3 bias, I <sub>O</sub> = ±20 μA	2/3 V <sub>DD</sub> - 1.0		2/3 V <sub>DD</sub> + 1.0	V
	V <sub>MID3</sub>	S1 to S68: 1/3 bias, I <sub>O</sub> = ±20 μA	1/3 V <sub>DD</sub> - 1.0		1/3 V <sub>DD</sub> + 1.0	V
	V <sub>MID4</sub>	COM1 to COM3: 1/3 bias, I <sub>O</sub> = ±100 μA	2/3 V <sub>DD</sub> - 1.0		2/3 V <sub>DD</sub> + 1.0	V
	V <sub>MID5</sub>	COM1 to COM3: 1/3 bias, I <sub>O</sub> = ±100 μA	1/3 V <sub>DD</sub> - 1.0		1/3 V <sub>DD</sub> + 1.0	V
Oscillator frequency	f <sub>OSC</sub>	OSC: R <sub>OSC</sub> = 180 kΩ, C <sub>OSC</sub> = 220 pF	30.4	38	45.6	kHz
Current drain	I <sub>DD1</sub>	Power-saving mode			5	μA
	I <sub>DD2</sub>	V <sub>DD</sub> = 6.0 V, outputs open, 1/2 bias, f <sub>OSC</sub> = 38 kHz		300	600	μA
	I <sub>DD3</sub>	V <sub>DD</sub> = 6.0 V, outputs open, 1/3 bias, f <sub>OSC</sub> = 38 kHz		250	500	μA

Note: \* Excluding the bias voltage generation divider resistors built in the V<sub>DD1</sub> and V<sub>DD2</sub>. (See Figure 1.)

1. When CL is stopped at the low level

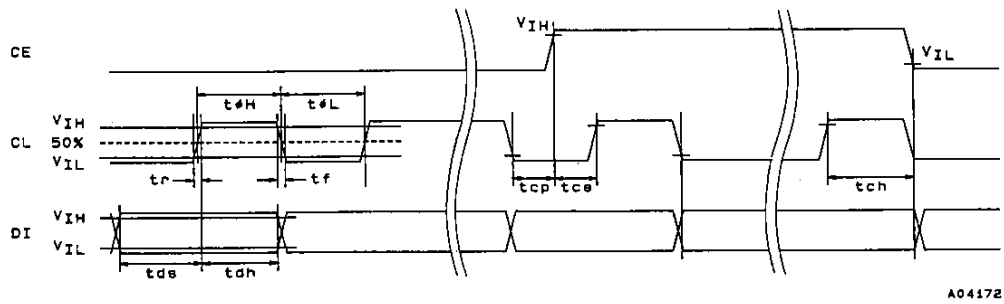

2. When CL is stopped at the high level

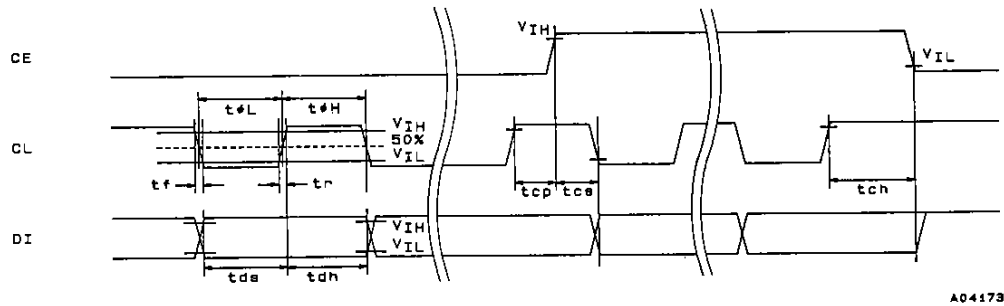
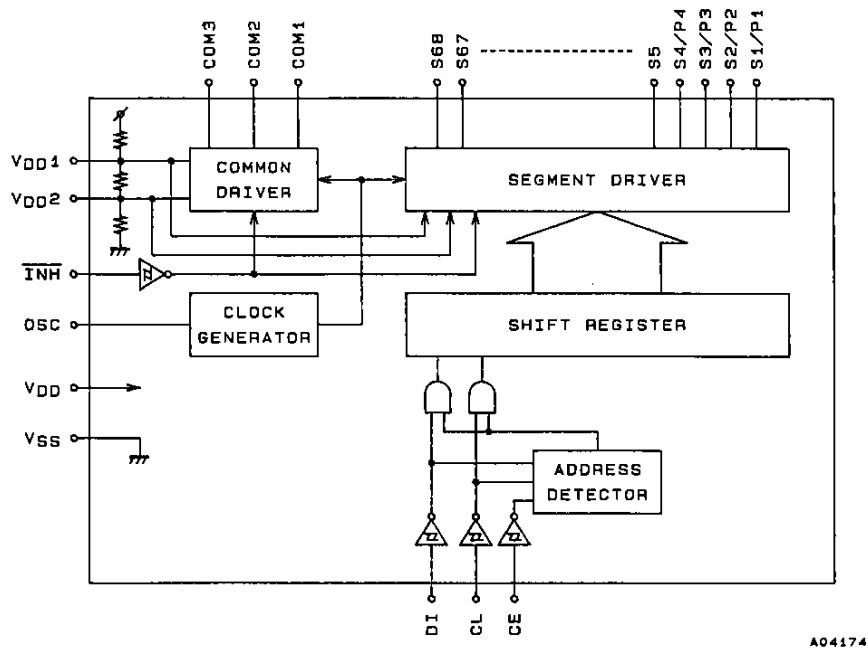



Figure 2

Block Diagram



LC75873NE, 75873NW

Pin Functions

Pin No.		Symbol	Function	Active	I/O	Handling when unused
LC75873NE	LC75873NW					
1 to 4 5 to 6B	79, 80, 1, 2 3 to 6B	S1/P1 to S4/P4 S5 to S6B	Segments outputs for displaying the display data transferred by serial data input. The S1/P1 to S4/P4 pins can be used as general-purpose output ports under serial data control.	—	O	Open
69 70 71	67 68 69	COM1 COM2 COM3	Common driver outputs. The frame frequency $f_o$ is $f_{OSC}/384$ Hz.	—	O	Open
76	74	OSC	Oscillator connection. An oscillator circuit can be formed by connecting an external resistor and capacitor at this pin.	—	I/O	GND
78 79 80	76 77 78	CE CL DI	Serial data transfer inputs. Connected to the controller. CE: Chip enable CL: Synchronization clock DI: Transfer data	H  —	I I I	GND
77	75	$\overline{INH}$	Display off control input $\overline{INH} = \text{low } (V_{SS}) \dots \dots$ Display forced off S1/P1 to S4/P4 = low (These pins are forcibly set to the segment output port function and held at the low level.) S5 to S6B = low COM1 to COM3 = low $\overline{INH} = \text{high } (V_{DD}) \dots \dots$ Display on However, serial data transfer is possible when the display is forced off by this pin.	L	I	GND
73	71	$V_{DD1}$	Used to apply the LCD drive 2/3 bias voltage externally. Connect this pin to $V_{DD2}$ when using a 1/2-bias drive scheme.	—	I	Open
74	72	$V_{DD2}$	Used to apply the LCD drive 1/3 bias voltage externally. Connect this pin to $V_{DD1}$ when using a 1/2-bias drive scheme.	—	I	Open
72	70	$V_{DD}$	Power supply. Provide a voltage of between 3.0 and 6.0 V.	—	—	—
75	73	$V_{SS}$	Power supply. Connect to ground.	—	—	—

**Serial Data Input**

1. When CL is stopped at the low level

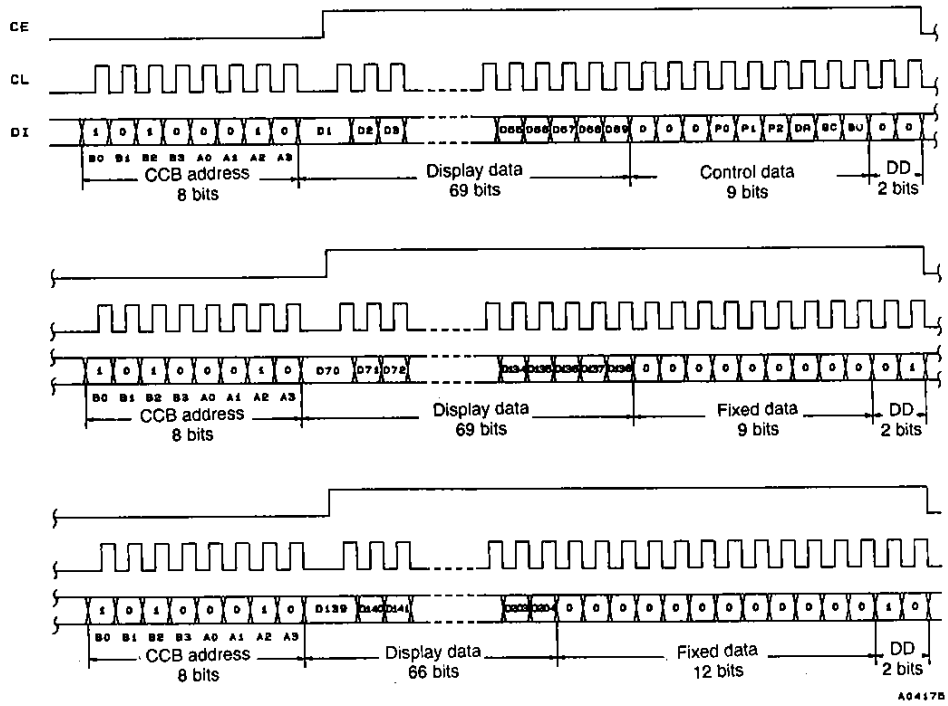

Note: DD is the direction data.

2. When CL is stopped at the high level

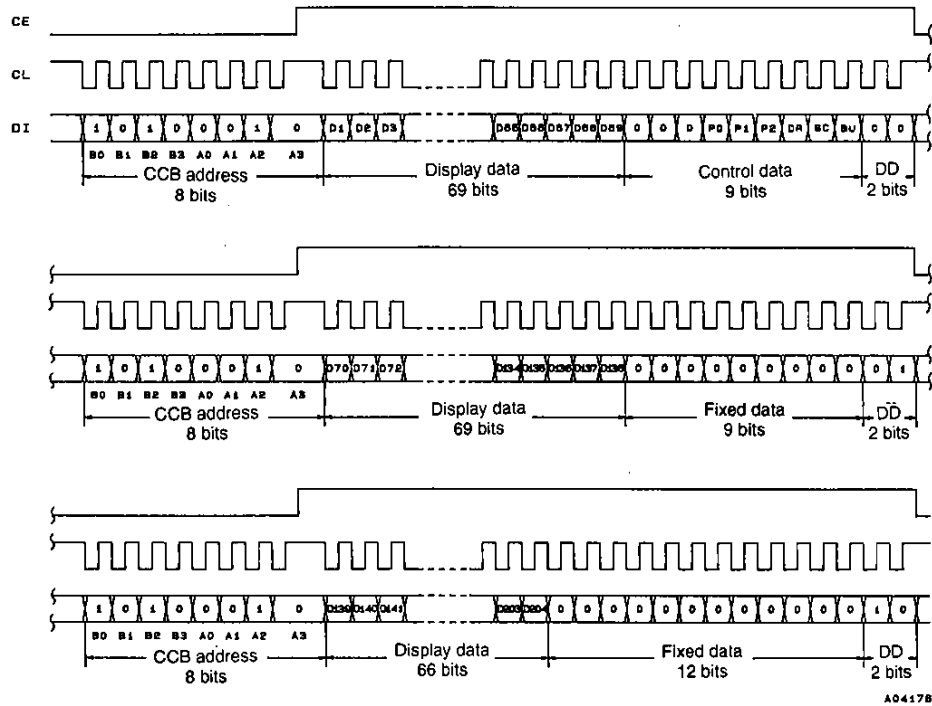

Note: DD is the direction data.

- CCB address.....45H
- D1 to D204.....Display data
- P0 to P2 .....Segment output port/general-purpose output port switching control data
- DR .....1/2-bias drive or 1/3-bias drive switching control data
- SC.....Segments on/off control data
- BU .....Normal mode/power-saving mode control data

**Serial Data Transfer Example**

1. When 139 or more segments are used  
All 240 bits of serial data must be sent.

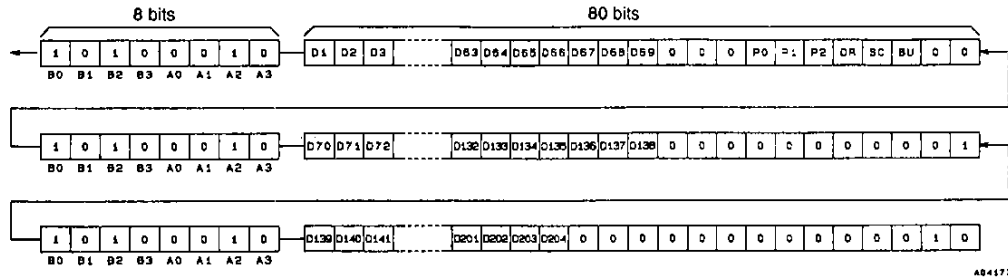

2. When fewer than 139 segments are used  
Either 80 or 160 bits of serial data may be sent, depending on the number of segments used. However, the serial data shown below (the D1 to D69 display data and the control data) must be sent.

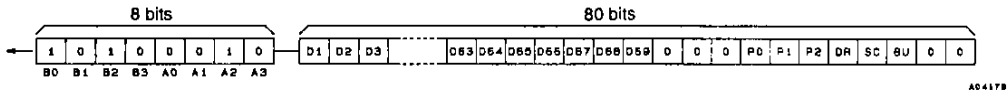

**Control Data Functions**

1. P0 to P2: Segment output port/general-purpose output port switching control data  
These control data bits switch the segment output port/general-purpose output port functions of the S1/P1 to S4/P4 output pins.

Control data			Output pin state			
P0	P1	P2	S1/P1	S2/P2	S3/P3	S4/P4
0	0	0	S1	S2	S3	S4
0	0	1	P1	S2	S3	S4
0	1	0	P1	P2	S3	S4
0	1	1	P1	P2	P3	S4
1	0	0	P1	P2	P3	P4

Note: Sn (n = 1 to 4): Segment output port function  
Pn (n = 1 to 4): General-purpose output port function

Note that when the general-purpose output port function is selected, the correspondence between the output pins and the display data will be that shown in the table.

Output pin	Corresponding display data
S1/P1	D1
S2/P2	D4
S3/P3	D7
S4/P4	D10

For example, if the general-purpose output port function is selected for the S4/P4 output pin, that output pin will output a high level when the display data D10 is 1, and a low level when the D10 is 0.



2. DR: 1/2-bias drive or 1/3-bias drive switching control data

This control data bit selects either 1/2-bias drive or 1/3-bias drive.

DR	Drive scheme
0	1/3-bias drive
1	1/2-bias drive

3. SC: Segment on/off control data

This control data controls the on/off state of the segments.

SC	Display state
0	On
1	Off

Note that when the segments are turned off by setting SC to 1, the segments are turned off by outputting segment off waveforms from the segment output pins.

4. BU: Normal mode/power-saving mode control data

This control data bit selects either normal mode or power-saving mode.

BU	Mode
0	Normal mode
1	Power saving mode. In this mode, the OSC pin oscillator is stopped and the common and segment output pins go low. However, the S1/P1 to S4/P4 output pins can be used as general-purpose output ports under the control of the data bits P0 to P2.

## Display Data and Output Pin Correspondence

Output pin	COM1	COM2	COM3
S1/P1	D1	D2	D3
S2/P2	D4	D5	D6
S3/P3	D7	D8	D9
S4/P4	D10	D11	D12
S5	D13	D14	D15
S6	D16	D17	D18
S7	D19	D20	D21
S8	D22	D23	D24
S9	D25	D26	D27
S10	D28	D29	D30
S11	D31	D32	D33
S12	D34	D35	D36
S13	D37	D38	D39
S14	D40	D41	D42
S15	D43	D44	D45
S16	D46	D47	D48
S17	D49	D50	D51
S18	D52	D53	D54
S19	D55	D56	D57
S20	D58	D59	D60
S21	D61	D62	D63
S22	D64	D65	D66
S23	D67	D68	D69
S24	D70	D71	D72
S25	D73	D74	D75
S26	D76	D77	D78
S27	D79	D80	D81
S28	D82	D83	D84
S29	D85	D86	D87
S30	D88	D89	D90
S31	D91	D92	D93
S32	D94	D95	D96
S33	D97	D98	D99
S34	D100	D101	D102

Output pin	COM1	COM2	COM3
S35	D103	D104	D105
S36	D106	D107	D108
S37	D109	D110	D111
S38	D112	D113	D114
S39	D115	D116	D117
S40	D118	D119	D120
S41	D121	D122	D123
S42	D124	D125	D126
S43	D127	D128	D129
S44	D130	D131	D132
S45	D133	D134	D135
S46	D136	D137	D138
S47	D139	D140	D141
S48	D142	D143	D144
S49	D145	D146	D147
S50	D148	D149	D150
S51	D151	D152	D153
S52	D154	D155	D156
S53	D157	D158	D159
S54	D160	D161	D162
S55	D163	D164	D165
S56	D166	D167	D168
S57	D169	D170	D171
S58	D172	D173	D174
S59	D175	D176	D177
S60	D178	D179	D180
S61	D181	D182	D183
S62	D184	D185	D186
S63	D187	D188	D189
S64	D190	D191	D192
S65	D193	D194	D195
S66	D196	D197	D198
S67	D199	D200	D201
S68	D202	D203	D204

Note: This table assumes that the segment output port function is selected for the S1/P1 to S4/P4 output pins.

For example, the table below lists the output states for the S11 output pin.

Display data			Output pin (S11) state
D31	D32	D33	
0	0	0	The LCD segments for COM1, COM2 and COM3 are off.
0	0	1	The LCD segment for COM3 is on (lit).
0	1	0	The LCD segment for COM2 is on.
0	1	1	The LCD segments for COM2 and COM3 are on.
1	0	0	The LCD segment for COM1 is on.
1	0	1	The LCD segments for COM1 and COM3 are on.
1	1	0	The LCD segments for COM1 and COM2 are on.
1	1	1	The LCD segments for COM1, COM2 and COM3 are on.

1/3-Duty 1/2-Bias Drive Scheme

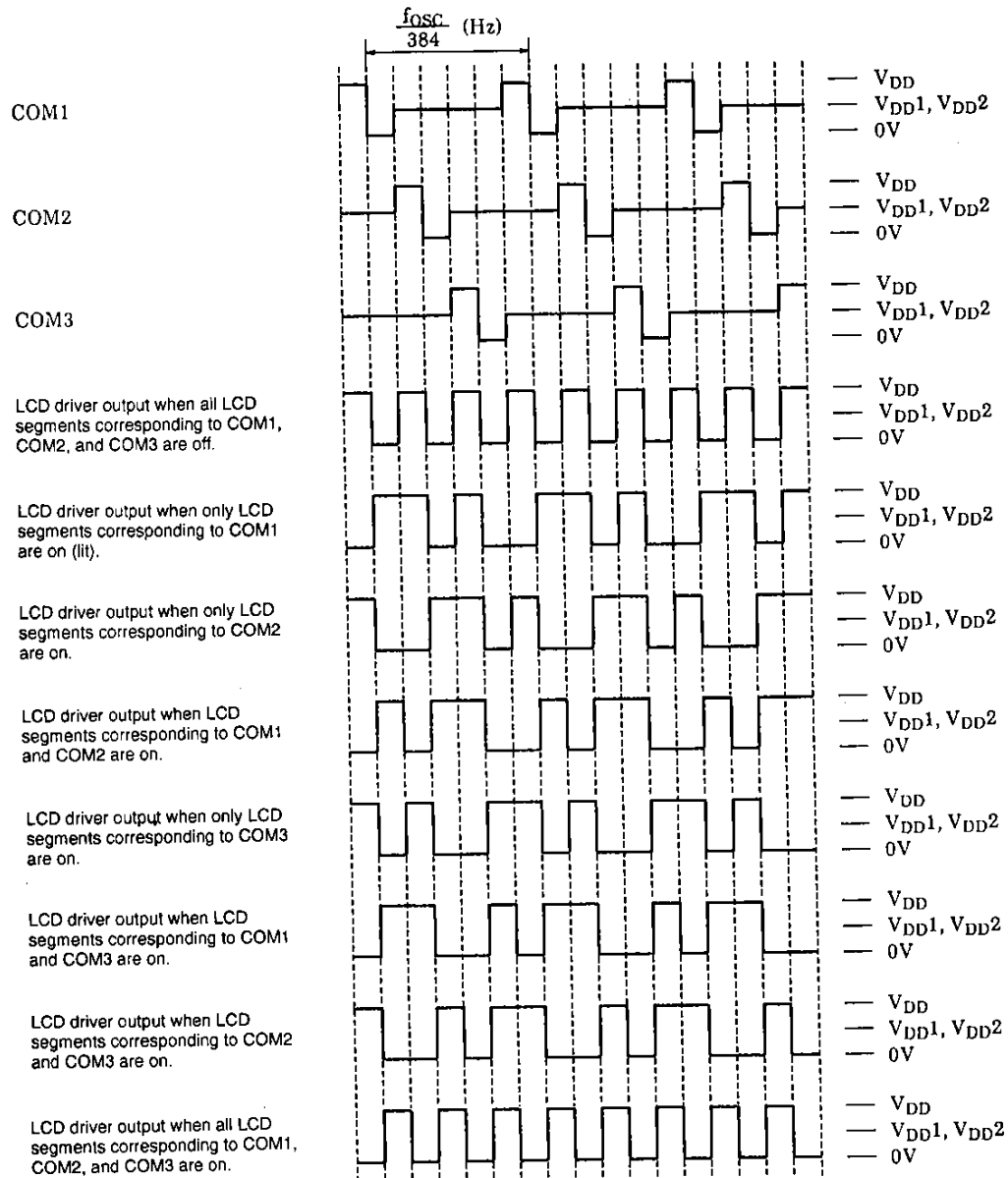

A04179

1/3-Duty 1/2-Bias Waveforms



### Display Control and the $\overline{\text{INH}}$ Pin

Since the LSI internal data (the display data D1 to D204 and the control data) is undefined when power is first applied, applications should prevent meaningless displays with the following procedure. First, set the  $\overline{\text{INH}}$  pin low at the same time as power is applied to turn off the display. This will set the S1/P1 to S4/P4, S5 to S68, and COM1 to COM3 pins low. While the  $\overline{\text{INH}}$  pin is held low, the control microprocessor should send the serial data. Finally, the application can set the  $\overline{\text{INH}}$  pin to high. (See Figure 3.)

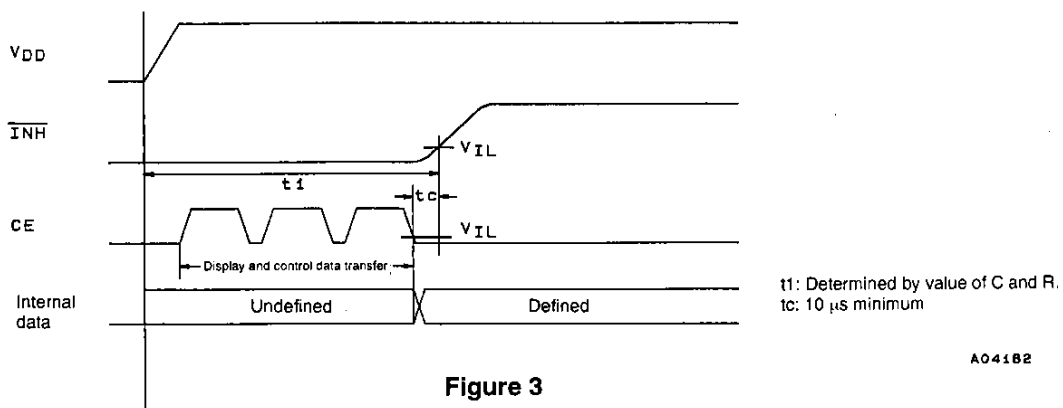
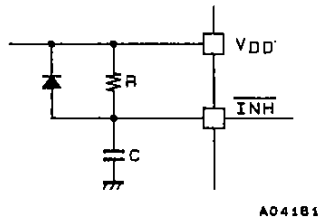

Figure 3

### Notes on Controller Transfer of Display Data

Since the LC75873NE and LC75873NW accept the display data divided into four separate transfer operations, we recommend that applications make a point of completing all four data transfers within a period of no more than 30 ms to guarantee the quality of the displayed image.

**Sample Application Circuit 1**

1/2 Bias (For normal LCD panels)

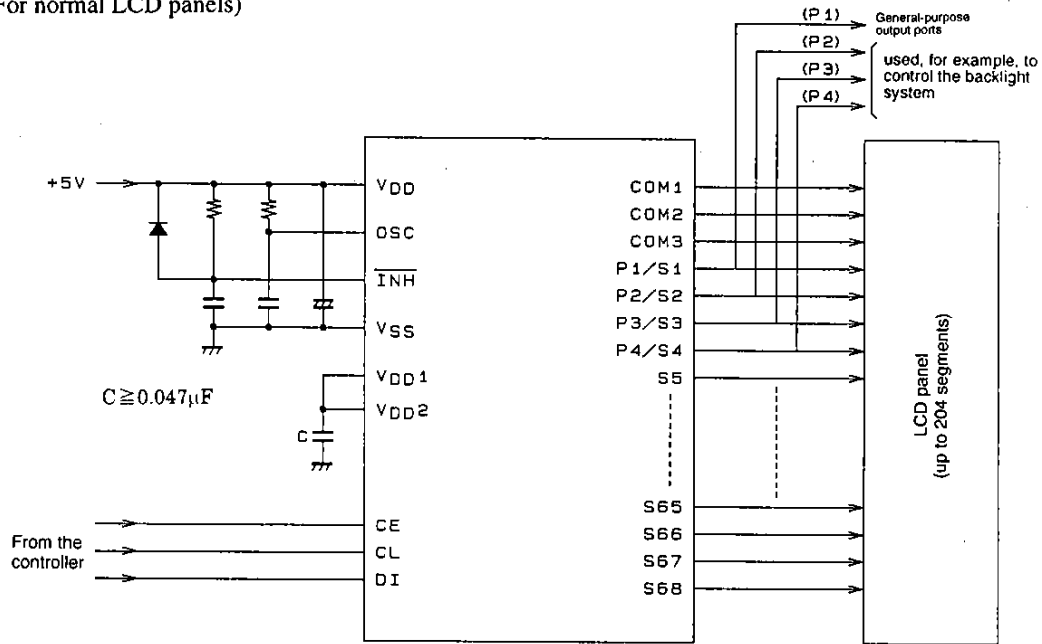

A05617

**Sample Application Circuit 2**

1/3 Bias (for normal LCD panels)

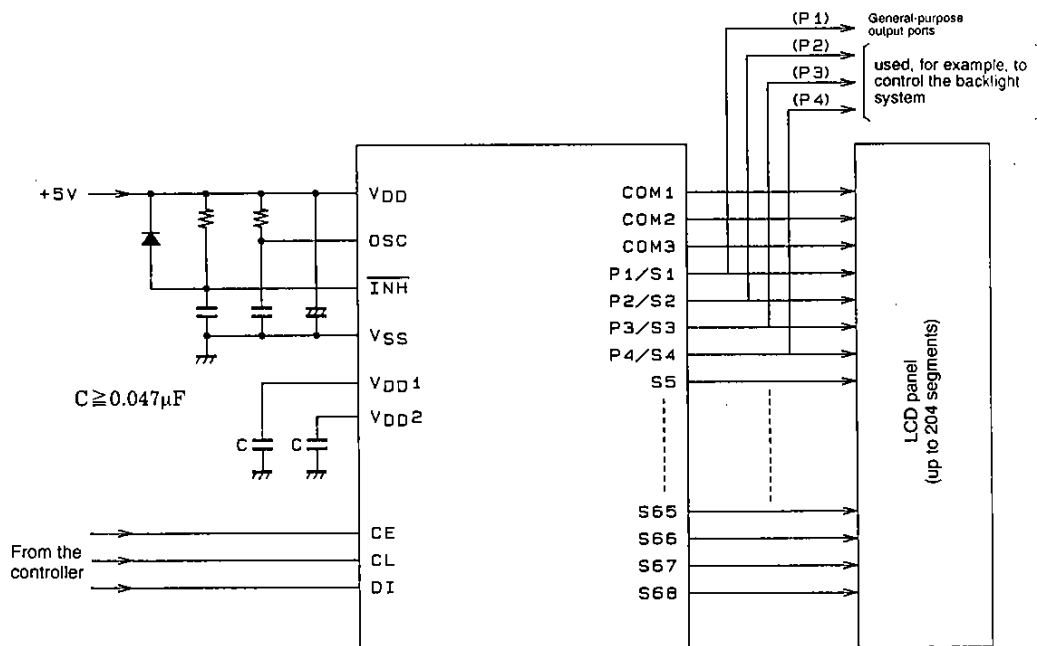

A05618

Sample Application Circuit 3

1/3 Bias (for large LCD panels)

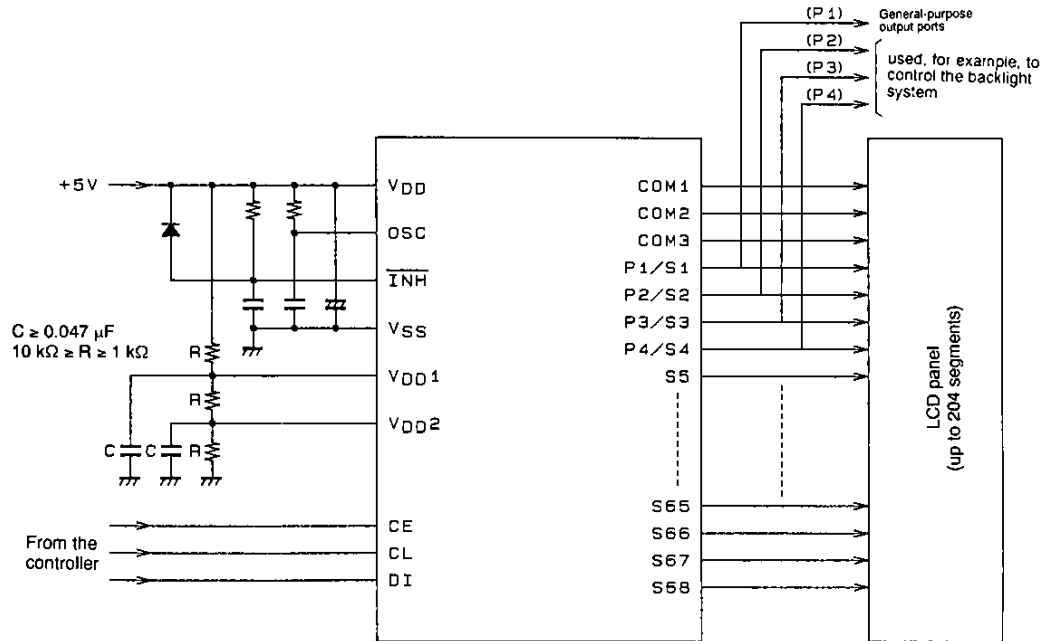

A05619

- No products described or contained herein are intended for use in surgical implants, life-support systems, aerospace equipment, nuclear power control systems, vehicles, disaster/crime-prevention equipment and the like, the failure of which may directly or indirectly cause injury, death or property loss.
- Anyone purchasing any products described or contained herein for an above-mentioned use shall:
  - ① Accept full responsibility and indemnify and defend SANYO ELECTRIC CO., LTD., its affiliates, subsidiaries and distributors and all their officers and employees, jointly and severally, against any and all claims and litigation and all damages, cost and expenses associated with such use:
  - ② Not impose any responsibility for any fault or negligence which may be cited in any such claim or litigation on SANYO ELECTRIC CO., LTD., its affiliates, subsidiaries and distributors or any of their officers and employees jointly or severally.
- Information (including circuit diagrams and circuit parameters) herein is for example only; it is not guaranteed for volume production. SANYO believes information herein is accurate and reliable, but no guarantees are made or implied regarding its use or any infringements of intellectual property rights or other rights of third parties.

This catalog provides information as of June, 1996. Specifications and information herein are subject to change without notice.