



**LC7940YD,7941YD**

**Dot-matrix LCD Drivers**

**Overview**

The LC7940YD and LC7941YD are segment driver ICs for driving large, dot-matrix LCD displays. They read 4-bit parallel or serial input, display data from a controller into an 80-bit latch, and then generate LCD drive signals corresponding to that data.

The LC7940YD and LC7941YD feature mirror-image pin assignments, allowing them to be used together to increase component density. They are designed to be used with the LC7942YD common driver to drive large LCD panels.

**Features**

- 80 built-in LCD display drive circuits
- 1/8 to 1/128 display duty cycle
- Serial or 4-bit parallel data input
- Chip disable for low power dissipation for large-sized panels
- Bias supply voltages can be supplied externally
- Operating supply voltage and ambient temperature
  - 2.7 to 5.5 V logic supply ( $V_{DD}$ ) at  $T_a = -20$  to  $+85^\circ\text{C}$
  - 8 to 20V LCD supply ( $V_{DD} - V_{EE}$ ) at  $T_a = -20$  to  $+85^\circ\text{C}$
- CMOS process
- 100-pin flat plastic package

**Package Dimensions**

unit: mm

**3180-QIP100D**

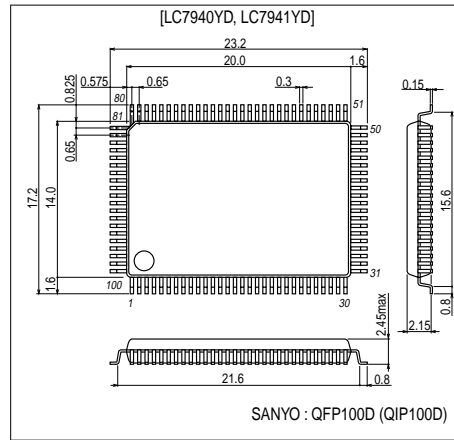

**Specifications**

**Absolute Maximum Ratings** at  $T_a = 25 \pm 2^\circ\text{C}$ ,  $V_{SS} = 0\text{ V}$

| Parameter                           | Symbol                | Ratings                | Unit |
|-------------------------------------|-----------------------|------------------------|------|
| Logic supply voltage                | $V_{DD}$ max          | -0.3 to +7.0           | V    |
| LCD supply voltage, See Note below. | $V_{DD} - V_{EE}$ max | 0 to 22                | V    |
| Input voltage                       | $V_I$ max             | -0.3 to $V_{DD} + 0.3$ | V    |

■ Any and all SANYO products described or contained herein do not have specifications that can handle applications that require extremely high levels of reliability, such as life-support systems, aircraft's control systems, or other applications whose failure can be reasonably expected to result in serious physical and/or material damage. Consult with your SANYO representative nearest you before using any SANYO products described or contained herein in such applications.

■ SANYO assumes no responsibility for equipment failures that result from using products at values that exceed, even momentarily, rated values (such as maximum ratings, operating condition ranges, or other parameters) listed in products specifications of any and all SANYO products described or contained herein.

**SANYO Electric Co., Ltd. Semiconductor Company**  
 TOKYO OFFICE Tokyo Bldg., 1-10, 1 Chome, Ueno, Taito-ku, TOKYO, 110-8534 JAPAN

**LC7940YD, LC7941YD**

| Parameter                   | Symbol    | Ratings     | Unit |
|-----------------------------|-----------|-------------|------|
| Operating temperature range | $T_{opr}$ | -20 to +85  | °C   |
| Storage temperature range   | $T_{stg}$ | -40 to +125 | °C   |

**Note**

$$V_{DD} \geq V_1 > V_3 > V_4 > V_{EE}$$

**Recommended Operating Conditions** at  $T_a = -20$  to  $+85^\circ\text{C}$ ,  $V_{SS} = 0\text{V}$

| Parameter                    | Symbol            | Conditions   | Ratings     |     |             | Unit |
|------------------------------|-------------------|--|-------------|-----|-------------|------|
|                              |                   |  | min         | typ | max         |      |
| Logic supply voltage         | $V_{DD}$          |  | 2.7         | -   | 5.5         | V    |
| LCD supply voltage           | $V_{DD} - V_{EE}$ | See Notes 1 and 2.                                 | 8           | -   | 20          | V    |
| HIGH-level input voltage     | $V_{IH}$          | CP, CDI, DI1 to DI3, M, SDI, P/S, DISPOFF and LOAD | $0.8V_{DD}$ | -   | -           | V    |
| LOW-level input voltage      | $V_{IL}$          | CP, CDI, DI1 to DI3, M, SDI, P/S, DISPOFF and LOAD | -           | -   | $0.2V_{DD}$ | V    |
| CP shift clock frequency     | $f_{CP}$          |  |             | -   | 3.3         | MHz  |
| CP pulsewidth                | $t_{WC}$          |  | 100         | -   | -           | ns   |
| LOAD pulsewidth              | $t_{WL}$          |  | 100         | -   | -           | ns   |
| Din and SDI to CP setup time | $t_{SETUP}$       |  | 80          | -   | -           | ns   |
| Din and SDI to CP hold time  | $t_{HOLD}$        |  | 80          | -   | -           | ns   |
| CP to LOAD time              | $t_{CL1}$         |  | 0           | -   | -           | ns   |
|                              | $t_{CL2}$         |  | 100         | -   | -           | ns   |
| LOAD to CP time              | $t_{LC}$          |  | 100         | -   | -           | ns   |
| CP rise time                 | $t_R$             |  | -           | -   | 50          | ns   |
| CP fall time                 | $t_F$             |  | -           | -   | 50          | ns   |
| LOAD rise time               | $t_{RL}$          |  | -           | -   | 50          | ns   |
| LOAD fall time               | $t_{FL}$          |  | -           | -   | 50          | ns   |

**Notes**

- $V_{DD} \geq V_1 > V_3 > V_4 > V_{EE}$
- At turn ON, the LCD supply should be energized after or simultaneously with the logic supply. At turn OFF, the logic supply should be cut after or simultaneously with the LCD supply.

**Electrical Characteristics** at  $T_a = 25 \pm 2^\circ\text{C}$ ,  $V_{SS} = 0\text{V}$ ,  $V_{DD} = 2.7$  to  $5.5\text{V}$

| Parameter                     | Symbol   | Conditions   | Ratings        |     |     | Unit             |
|-------------------------------|----------|--|----------------|-----|-----|------------------|
|                               |          |  | min            | typ | max |                  |
| HIGH-level input current      | $I_{IH}$ | $V_{IN} = V_{DD}$ ; LOAD, CP, CDI, P/S, DI1 to DI3, SDI, M, and DISPOFF              | -              | -   | 1   | $\mu\text{A}$    |
| LOW-level input current       | $I_{IL}$ | $V_{IN} = V_{SS}$ ; LOAD, CP, CDI, P/S, DI1 to DI3, SDI, M, and DISPOFF              | -              | -   | -1  | $\mu\text{A}$    |
| CDO HIGH-level output voltage | $V_{OH}$ | $I_{OH} = -400\ \mu\text{A}$   | $V_{DD} - 0.4$ | -   | -   | V                |
| CDO LOW-level output voltage  | $V_{OL}$ | $I_{OL} = 400\ \mu\text{A}$  | -              | -   | 0.4 | V                |
| O1 to O8 driver ON resistance | $R_{ON}$ | $V_{DD} - V_{EE} = 18\text{V}$ ,<br>$ V_{DE} - V_{OL}  = 0.25\text{V}$ .<br>See note | -              | 2   | 4   | $\text{k}\Omega$ |

## LC7940YD, LC7941YD

| Parameter                                     | Symbol   | Conditions   | Ratings |     |     | Unit          |
|---|----------|--|---------|-----|-----|---------------|
|   |          |  | min     | typ | max |               |
| $V_{DD}$ to $V_{SS}$ standby supply current   | $I_{ST}$ | $C_{DI} = V_{DD}$<br>$V_{DD} - V_{EE} = 18\text{ V}$ ,<br>$f_{CP} = 3.3\text{ MHz}$ ,<br>no output load; $V_{SS}$                      | -       | -   | 200 | $\mu\text{A}$ |
| $V_{DD}$ to $V_{SS}$ operating supply current | $I_{SS}$ | $V_{DD} - V_{EE} = 18\text{ V}$ ,<br>$f_{CP} = 3.3\text{ MHz}$ ,<br>$I_{LOAD} = 5.156\text{ kHz}$ ,<br>$f_M = 52\text{ Hz}$ ; $V_{SS}$ | -       | -   | 1.0 | $\text{mA}$   |
| $V_{DD}$ to $V_{EE}$ operating supply current | $I_{EE}$ | $V_{DD} - V_{EE} = 18\text{ V}$ ,<br>$f_{CP} = 3.3\text{ MHz}$ ,<br>$I_{LOAD} = 5.156\text{ kHz}$ ,<br>$f_M = 52\text{ Hz}$ ; $V_{EE}$ | -       | -   | 0.1 | $\text{mA}$   |
| CP input capacitance                          | $C_i$    | $f_{CP} = 3.3\text{ MHz}$ ; CP   | -       | 5   | -   | $\text{pF}$   |

**Note**

$V_{DD} = V_1$  or  $V_3$ , or  $V_4$  or  $V_{EE}$ ;  $V_1 = V_{DD}$ ;  $V_3 = 9/11 \times (V_{DD} - V_{EE})$ ;  $V_4 = 2/11 \times (V_{DD} - V_{EE})$

**Switching Characteristics** at  $T_a = 25 \pm 2^\circ\text{C}$ ,  $V_{SS} = 0\text{ V}$ ,  $V_{DD} = 2.7$  to  $5.5\text{ V}$

| Parameter             | Symbol | Conditions           | Ratings |     |     | Unit        |
|-----------------------|--------|----------------------|---------|-----|-----|-------------|
|                       |        |                      | min     | typ | max |             |
| CDO output delay time | $t_D$  | $C_L = 30\text{ pF}$ | -       | -   | 200 | $\text{ns}$ |

### Switching Characteristics Waveform

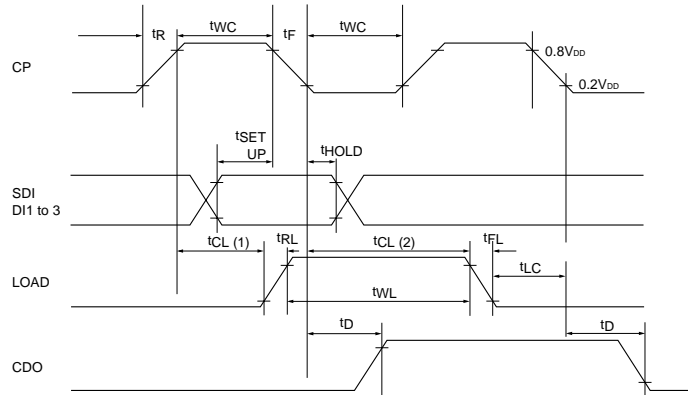

LC7940YD, LC7941YD

Pad Layout (Top view)

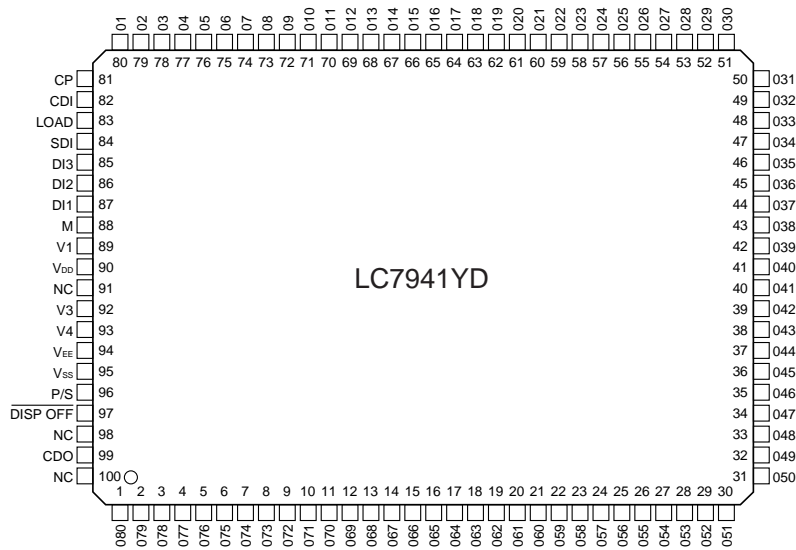
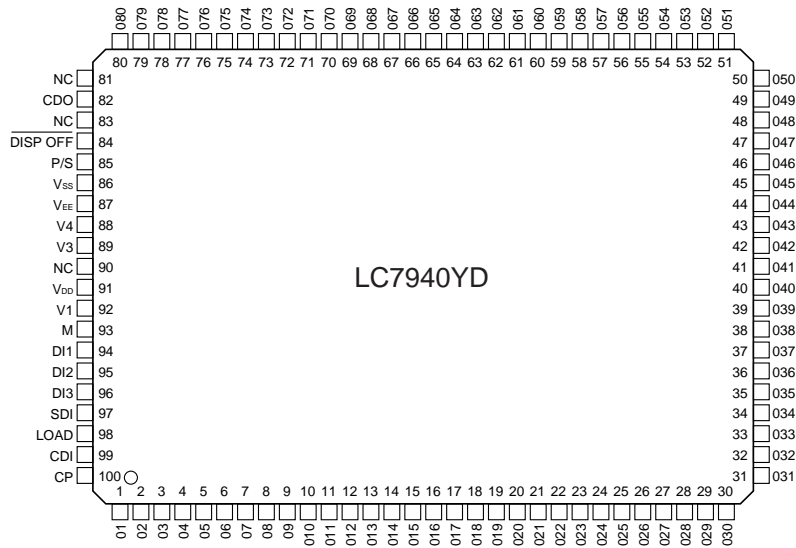

## LC7940YD, LC7941YD

### Block Diagram

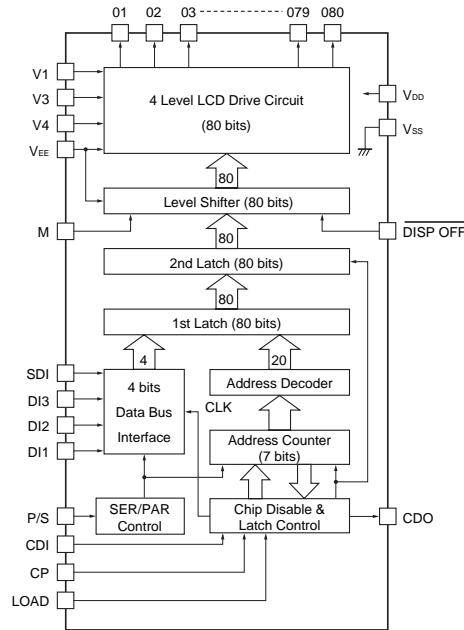

### Pin Functions

| Pin No.  |          | Symbol   | I/O    | Functions  |
|----------|----------|----------|--------|--|
| LC7940YD | LC7941YD |          |        |  |
| 91       | 90       | $V_{DD}$ | Supply | $V_{DD} - V_{SS}$ is the logic supply.<br>$V_{DD} - V_{EE}$ is the LCD supply.   |
| 86       | 95       | $V_{SS}$ |        |  |
| 87       | 94       | $V_{EE}$ |        |  |
| 92       | 89       | $V_1$    | Supply | LCD panel drive voltage supplies<br>$V_1$ and $V_{EE}$ are selected levels.<br>$V_3$ and $V_4$ are not-selected levels.            |
| 89       | 92       | $V_3$    |        |  |
| 88       | 93       | $V_4$    |        |  |
| 100      | 81       | CP       | I      | Display data Input clock (falling-edge trigger).   |
| 99       | 82       | CDI      | I      | Chip disable.<br>Data is read in when LOW, and not read in when HIGH.  |
| 98       | 83       | LOAD     | I      | Display data latch clock (falling-edge trigger).<br>On the falling edge, the LCD drive signals set by the display data are output. |
| 97       | 84       | SDI      | I      | Serial data input.   |

**LC7940YD, LC7941YD**

| Pin No.    |          | Symbol             | I/O   | Functions   |            |     |                    |        |     |     |      |                |     |      |      |                |      |     |      |                |      |      |      |                 |    |     |     |                |
|------------|----------|--------------------|---|---|------------|-----|--------------------|--------|-----|-----|------|----------------|-----|------|------|----------------|------|-----|------|----------------|------|------|------|-----------------|----|-----|-----|----------------|
| LC7940YD   | LC7941YD |                    |   |   |            |     |                    |        |     |     |      |                |     |      |      |                |      |     |      |                |      |      |      |                 |    |     |     |                |
| 96         | 85       | DI3                | I   | 4-bit parallel data input pins.<br><table border="1"> <thead> <tr> <th colspan="2">Data input</th> <th colspan="3">LCD driver outputs</th> </tr> </thead> <tbody> <tr> <td>SDI</td> <td>O4</td> <td>O8</td> <td rowspan="4">→</td> <td>O80</td> </tr> <tr> <td>DI3</td> <td>O3</td> <td>O7</td> <td>O79</td> </tr> <tr> <td>DI2</td> <td>O2</td> <td>O6</td> <td>O78</td> </tr> <tr> <td>DI1</td> <td>O1</td> <td>O5</td> <td>O77</td> </tr> </tbody> </table>  | Data input |     | LCD driver outputs |        |     | SDI | O4   | O8             | →   | O80  | DI3  | O3             | O7   | O79 | DI2  | O2             | O6   | O78  | DI1  | O1              | O5 | O77 |     |                |
| Data input |          | LCD driver outputs |   |   |            |     |                    |        |     |     |      |                |     |      |      |                |      |     |      |                |      |      |      |                 |    |     |     |                |
| SDI        | O4       | O8                 |   |   | →          | O80 |                    |        |     |     |      |                |     |      |      |                |      |     |      |                |      |      |      |                 |    |     |     |                |
| DI3        | O3       | O7                 | O79   |   |            |     |                    |        |     |     |      |                |     |      |      |                |      |     |      |                |      |      |      |                 |    |     |     |                |
| DI2        | O2       | O6                 | O78   |   |            |     |                    |        |     |     |      |                |     |      |      |                |      |     |      |                |      |      |      |                 |    |     |     |                |
| DI1        | O1       | O5                 | O77   |   |            |     |                    |        |     |     |      |                |     |      |      |                |      |     |      |                |      |      |      |                 |    |     |     |                |
| 95         | 86       | DI2                |   |   |            |     |                    |        |     |     |      |                |     |      |      |                |      |     |      |                |      |      |      |                 |    |     |     |                |
| 94         | 87       | D11                | In serial data input mode, DI1 to DI3 should all be tied HIGH or LOW. |   |            |     |                    |        |     |     |      |                |     |      |      |                |      |     |      |                |      |      |      |                 |    |     |     |                |
| 93         | 88       | M                  | I   | LCD panel drive voltage output alternation control signal.  |            |     |                    |        |     |     |      |                |     |      |      |                |      |     |      |                |      |      |      |                 |    |     |     |                |
| 85         | 96       | P/S                | I   | Data input mode select. 4-bit parallel input when HIGH, and serial input when LOW   |            |     |                    |        |     |     |      |                |     |      |      |                |      |     |      |                |      |      |      |                 |    |     |     |                |
| 82         | 99       | CDO                | O   | Cascade connection pin for extension segment drivers. Data is read out when HIGH. Goes LOW after data is read out. Connected to the CDI input of the next chip.   |            |     |                    |        |     |     |      |                |     |      |      |                |      |     |      |                |      |      |      |                 |    |     |     |                |
| 1 to 80    | 80 to 1  | O1 to O80          | O   | LCD drive outputs.<br>The output drive level is determined by the display data, M signal and DISP OFF input as shown below.<br><table border="1"> <thead> <tr> <th>M</th> <th>Q</th> <th>DISP OFF</th> <th>Output</th> </tr> </thead> <tbody> <tr> <td>LOW</td> <td>LOW</td> <td>HIGH</td> <td>V<sub>3</sub></td> </tr> <tr> <td>LOW</td> <td>HIGH</td> <td>HIGH</td> <td>V<sub>1</sub></td> </tr> <tr> <td>HIGH</td> <td>LOW</td> <td>HIGH</td> <td>V<sub>4</sub></td> </tr> <tr> <td>HIGH</td> <td>HIGH</td> <td>HIGH</td> <td>V<sub>EE</sub></td> </tr> <tr> <td>x</td> <td>x</td> <td>LOW</td> <td>V<sub>1</sub></td> </tr> </tbody> </table> | M          | Q   | DISP OFF           | Output | LOW | LOW | HIGH | V <sub>3</sub> | LOW | HIGH | HIGH | V <sub>1</sub> | HIGH | LOW | HIGH | V <sub>4</sub> | HIGH | HIGH | HIGH | V <sub>EE</sub> | x  | x   | LOW | V <sub>1</sub> |
| M          | Q        | DISP OFF           | Output  |   |            |     |                    |        |     |     |      |                |     |      |      |                |      |     |      |                |      |      |      |                 |    |     |     |                |
| LOW        | LOW      | HIGH               | V <sub>3</sub>  |   |            |     |                    |        |     |     |      |                |     |      |      |                |      |     |      |                |      |      |      |                 |    |     |     |                |
| LOW        | HIGH     | HIGH               | V <sub>1</sub>  |   |            |     |                    |        |     |     |      |                |     |      |      |                |      |     |      |                |      |      |      |                 |    |     |     |                |
| HIGH       | LOW      | HIGH               | V <sub>4</sub>  |   |            |     |                    |        |     |     |      |                |     |      |      |                |      |     |      |                |      |      |      |                 |    |     |     |                |
| HIGH       | HIGH     | HIGH               | V <sub>EE</sub>   |   |            |     |                    |        |     |     |      |                |     |      |      |                |      |     |      |                |      |      |      |                 |    |     |     |                |
| x          | x        | LOW                | V <sub>1</sub>  |   |            |     |                    |        |     |     |      |                |     |      |      |                |      |     |      |                |      |      |      |                 |    |     |     |                |
| 84         | 97       | DISPOFF            | I   | O1 to O80 output control input pin.<br>When LOW, V1 is output on the O1 to O80 outputs. See the truth table.  |            |     |                    |        |     |     |      |                |     |      |      |                |      |     |      |                |      |      |      |                 |    |     |     |                |
| 81         | 91       | NC                 | -   | No connection.  |            |     |                    |        |     |     |      |                |     |      |      |                |      |     |      |                |      |      |      |                 |    |     |     |                |
| 83         | 98       | NC                 |   |   |            |     |                    |        |     |     |      |                |     |      |      |                |      |     |      |                |      |      |      |                 |    |     |     |                |
| 90         | 100      | NC                 |   |   |            |     |                    |        |     |     |      |                |     |      |      |                |      |     |      |                |      |      |      |                 |    |     |     |                |

Application Notes

LCD Panel 1

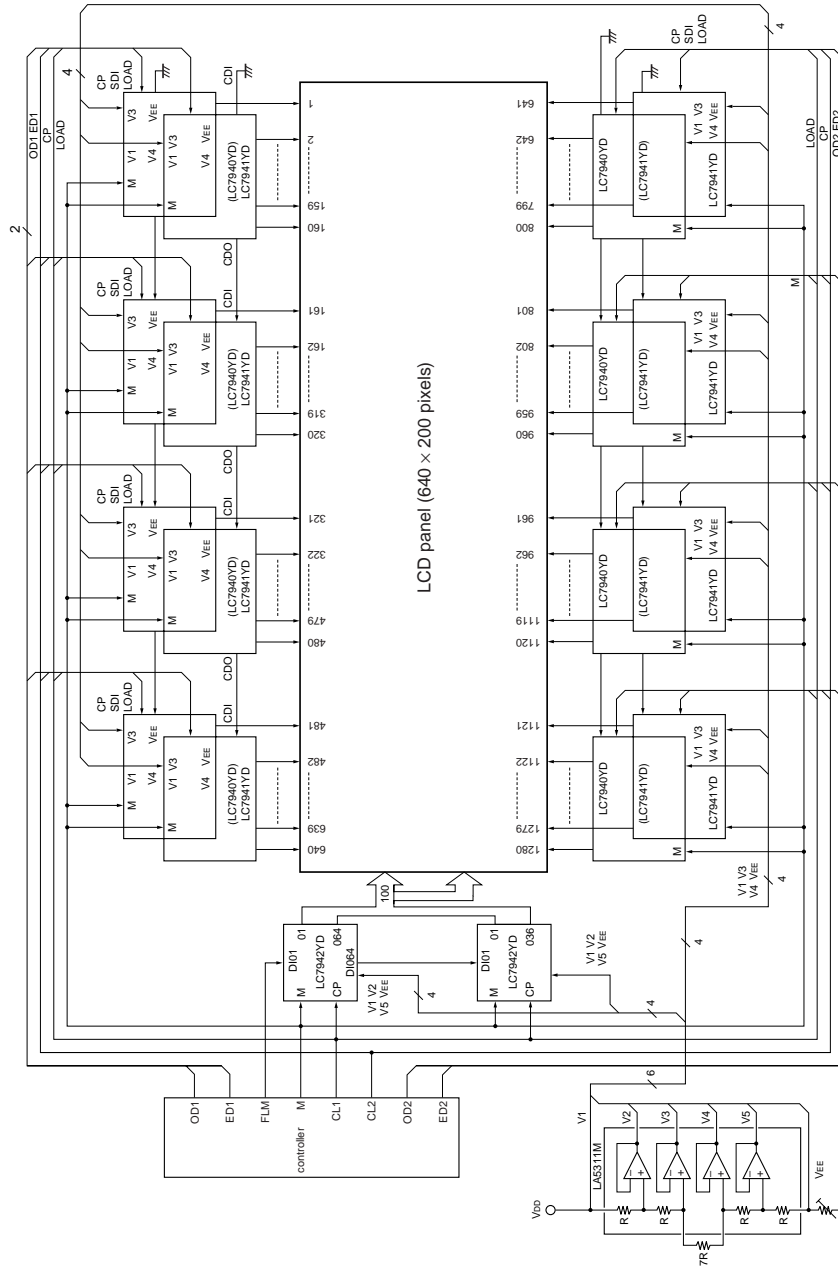

LCD Panel 2

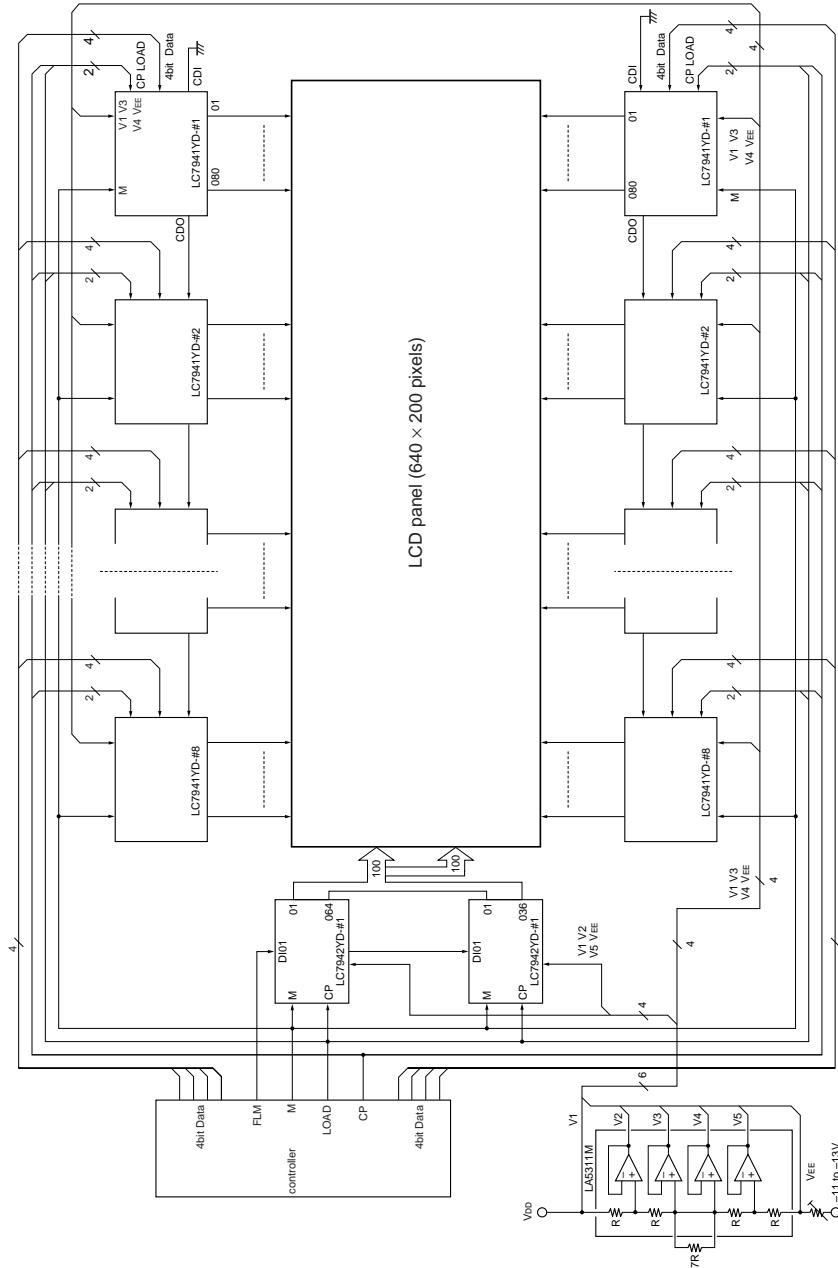



## LC7940YD, LC7941YD

### 100 × 240-pixel LCD Panel Application

A 100 × 240-pixel LCD panel requires the following drivers.

- 3 × LC7940YD (or LC7941YD) drivers
- 2 × LC7942YD drivers

An example using 1/100 duty cycle is shown below.

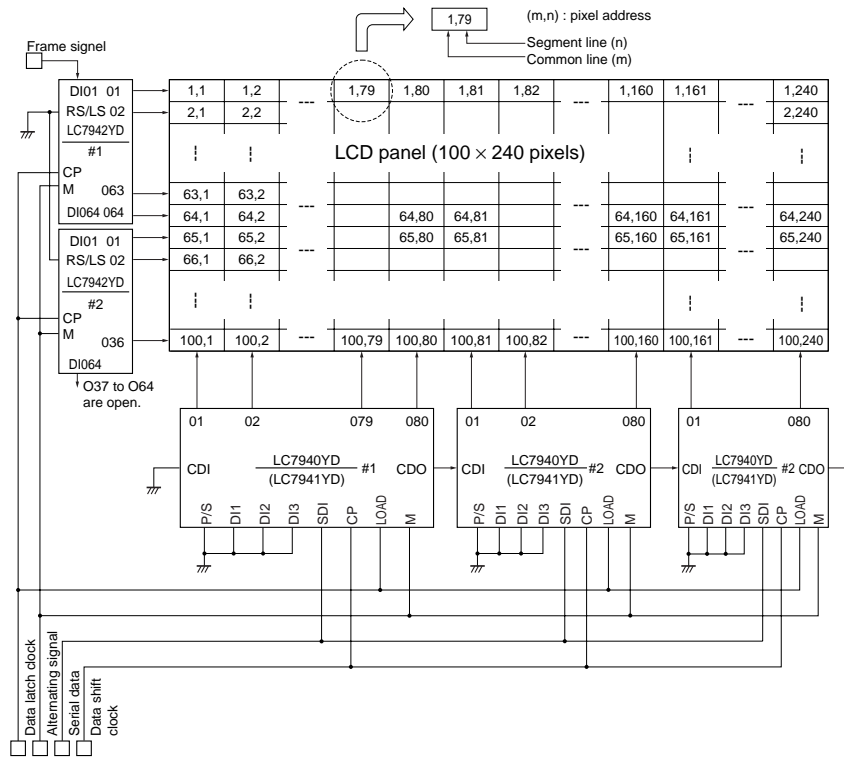

1. The LC7942YD chips are cascaded by connecting DIO64 on chip I to DIO1 on chip 2. For a 100-bit shift register, 037 to 064 on chip 2 are left open.
2. The LC7940YD (or LC7941YD) chips are cascaded by connecting CDO on chip I to CDI on chip 2, and CDO on chip 2 to CDI on chip 3. CDI on chip I is tied to GND, and CDO on chip 3 is not used. This configuration allows the input of 240-bit serial data.

100 x 240-pixel LCD Panel Timing Diagram

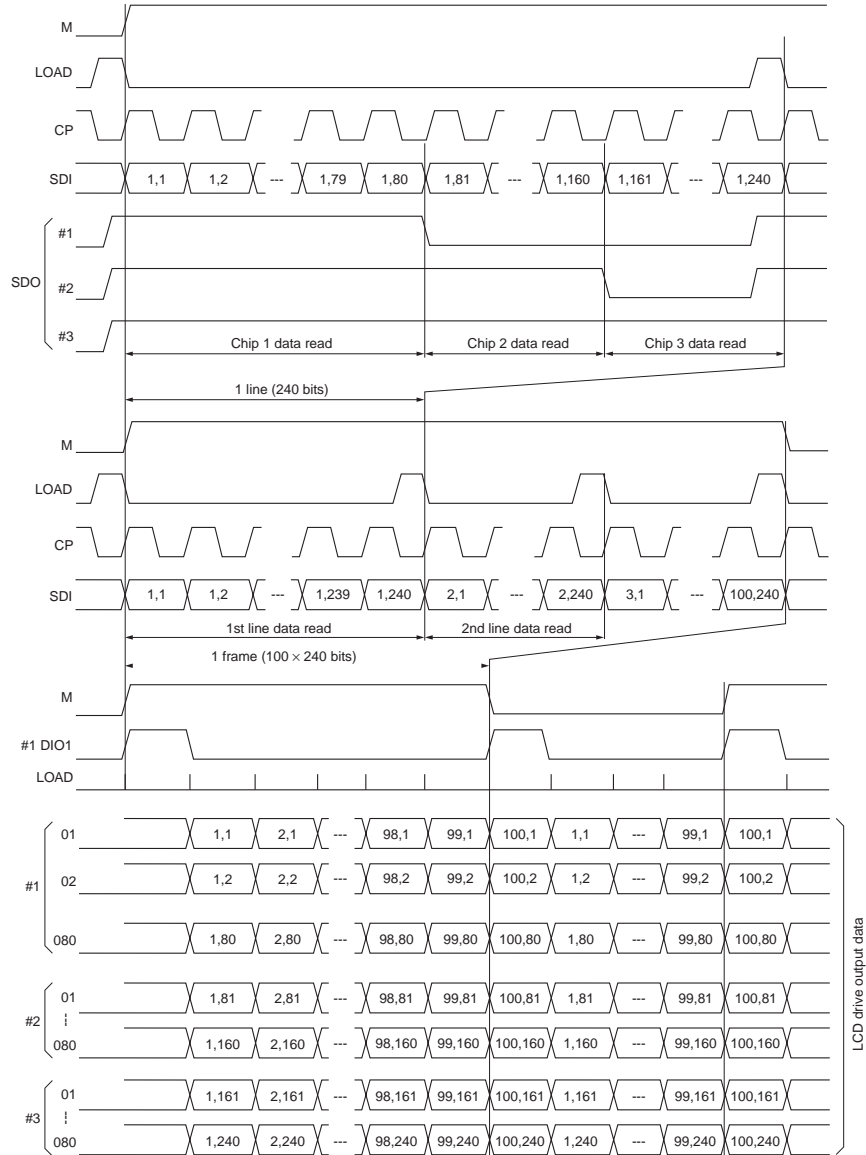

## LC7940YD, LC7941YD

### Segment Data Not Multiples of 4

Example.

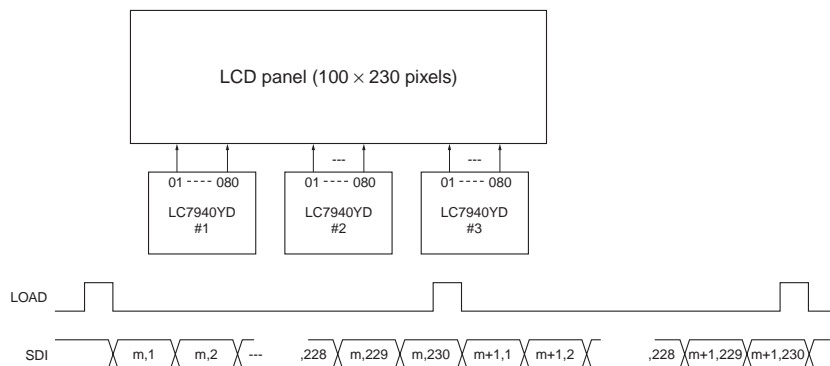

If this timing data is sent, data elements (m, 229), (m, 230), (m+1, 229), (m+1, 230)... will not appear in the output (O69 and O70 on chip 3). This is because the LC7940YD (or LC7941YD) converts serial/parallel data

in 4-bit units, which also decreases power dissipation. For data that is not a multiple of 4, like 230, the following scheme is used.

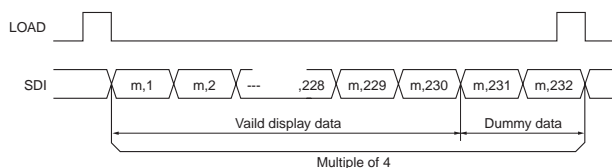

In this case, (m, 231) is output on O71 on chip 3, and (m, 232) on O72 on chip 3. However, these outputs are not

- Specifications of any and all SANYO products described or contained herein stipulate the performance, characteristics, and functions of the described products in the independent state, and are not guarantees of the performance, characteristics, and functions of the described products as mounted in the customer's products or equipment. To verify symptoms and states that cannot be evaluated in an independent device, the customer should always evaluate and test devices mounted in the customer's products or equipment.
- SANYO Electric Co., Ltd. strives to supply high-quality high-reliability products. However, any and all semiconductor products fail with some probability. It is possible that these probabilistic failures could give rise to accidents or events that could endanger human lives, that could give rise to smoke or fire, or that could cause damage to other property. When designing equipment, adopt safety measures so that these kinds of accidents or events cannot occur. Such measures include but are not limited to protective circuits and error prevention circuits for safe design, redundant design, and structural design.
- In the event that any or all SANYO products (including technical data, services) described or contained herein are controlled under any of applicable local export control laws and regulations, such products must not be exported without obtaining the export license from the authorities concerned in accordance with the above law.
- No part of this publication may be reproduced or transmitted in any form or by any means, electronic or mechanical, including photocopying and recording, or any information storage or retrieval system, or otherwise, without the prior written permission of SANYO Electric Co., Ltd.
- Any and all information described or contained herein are subject to change without notice due to product/technology improvement, etc. When designing equipment, refer to the "Delivery Specification" for the SANYO product that you intend to use.
- Information (including circuit diagrams and circuit parameters) herein is for example only; it is not guaranteed for volume production. SANYO believes information herein is accurate and reliable, but no guarantees are made or implied regarding its use or any infringements of intellectual property rights or other rights of third parties.

This catalog provides information as of June, 1999. Specifications and information herein are subject to change without notice.