

# MAXIM

## Dual Monolithic SPST CMOS Analog Switch

DG200A

### General Description

The DG200A is a dual, normally closed, single-pole-single-throw (SPST) analog switch. This CMOS switch can be operated with power supplies ranging from  $\pm 4.5V$  to  $\pm 18V$ . The DG200A has guaranteed break-before-make switching. Its maximum turn-off time is 500ns, and its maximum turn-on time is 100ns.

Maxim guarantees that the DG200A will not latch-up if the power supplies are turned off with input signals still connected as long as absolute maximum ratings are not violated.

Compared to the original manufacturer's product, Maxim's DG200A consumes significantly lower power, making it better suited for portable applications.

### Applications

- Winchester Disk Drives
- Test Equipment
- Communications Systems
- PBX, PABX
- Guidance and Control Systems
- Head up Displays
- Military Radios

### Features

- ◆ Improved 2nd Source Power Supply Current  $< 300\mu A$
- ◆ Wide Supply Range  $\pm 4.5V$  to  $\pm 18V$
- ◆ Single Supply Operation
- ◆ Non-Latching with Supplies Turned-off and Input Signals Present
- ◆ CMOS and TTL Logic Compatible
- ◆ Monolithic, Low Power CMOS Design

### Ordering Information

PART	TEMP. RANGE	PIN-PACKAGE
DG200AAK	-55°C to +125°C	14 Lead CERDIP
DG200ABK	-25°C to +85°C	14 Lead CERDIP*
DG200ACK	0°C to +70°C	14 Lead CERDIP
DG200ACJ	0°C to +70°C	14 Lead Plastic DIP
DG200ADJ	-40°C to +85°C	14 Lead Plastic DIP
DG200ACY	0°C to +70°C	14 Lead SO
DG200ADY	-40°C to +85°C	14 Lead SO
DG200AC/D	0°C to +70°C	Dice
DG200AAA	-55°C to +125°C	10 Pin Metal Can*
DG200ABA	-25°C to +85°C	10 Pin Metal Can*
DG200ACA	0°C to +70°C	10 Pin Metal Can*

\*Contact factory for availability.

### Pin Configuration

### Typical Operating Circuit

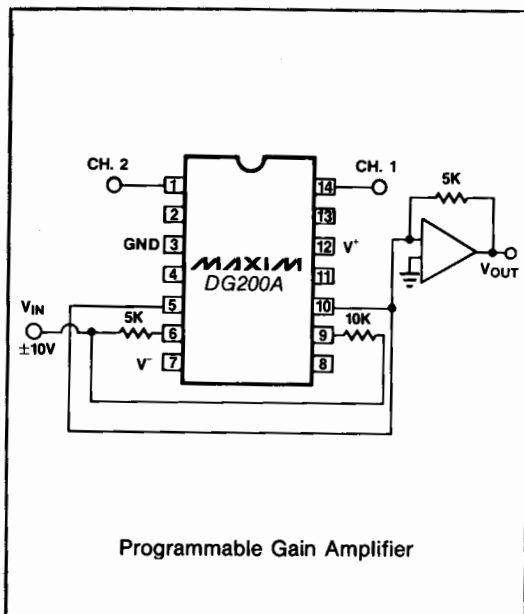

### Top View

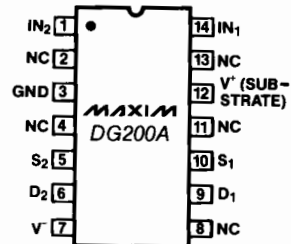

### V+ (SUBSTRATE AND CASE)

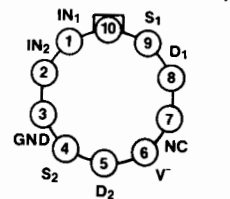

**MAXIM**

Maxim Integrated Products 1

For free samples & the latest literature: <http://www.maxim-ic.com>, or phone 1-800-998-8800

# Dual Monolithic SPST CMOS Analog Switch

## ABSOLUTE MAXIMUM RATINGS

Voltages Referenced to V <sup>-</sup>	Operating Temperature (A Suffix) .....	-55 to 125°C
V <sup>+</sup> .....	(B Suffix) .....	-25 to 85°C
GND .....	(C Suffix) .....	-25 to 85°C
Digital Inputs V <sub>S</sub> , V <sub>D</sub> (Note 1) .....	(D Suffix) .....	-40 to 85°C
or 20mA, whichever occurs first.	Power Dissipation (Package)*	
Current, Any Terminal Except S or D .....	Metal Can** .....	.450mW
Continuous Current, S or D .....	14 Pin Ceramic DIP*** .....	.825mW
(Pulsed at 1msec, 10% duty cycle max) .....	14 Pin Plastic DIP**** .....	.470mW
Storage Temperature (A & B Suffix) .....	* All leads soldered or welded to PC board.	
(C Suffix) .....	** Derate 6mW/°C above 75°C.	
	*** Derate 11mW/°C above 75°C.	
	**** Derate 6.5mW/°C above 25°C.	

Stresses listed under "Absolute Maximum Ratings" may be applied (one at a time) to devices without resulting in permanent damage. These are stress ratings only, and functional operation of the device at these or any other conditions above those indicated in the operational sections of the specifications is not implied. Exposure to absolute maximum rating conditions for extended periods may affect device reliability.

## ELECTRICAL CHARACTERISTICS (V<sup>+</sup> = +15V, V<sup>-</sup> = -15V, GND = 0V, T<sub>A</sub> = 25°C, unless otherwise indicated.)

PARAMETER	SYMBOL	TEST CONDITIONS	LIMITS						UNITS	
			DG200A			DG200 B/C/D				
			MIN	TYP	MAX	MIN	TYP	MAX		
<b>SWITCH</b>										
Analog Signal Range (Note 1)	V <sub>ANALOG</sub>		-15	15		-15	15		V	
Drain-Source ON Resistance	r <sub>DS(on)</sub>	V <sub>D</sub> = ±10V, V <sub>in</sub> = 0.8V, I <sub>S</sub> = 1mA		45	70		45	80	Ω	
Source OFF Leakage Current	I <sub>S(off)</sub>	V <sub>in</sub> = 2.4V	V <sub>S</sub> = 14V, V <sub>D</sub> = -14V		0.01	2.0	0.01		5.0	nA
Drain OFF Leakage Current	I <sub>D(off)</sub>		V <sub>S</sub> = -14V, V <sub>D</sub> = 14V		-2.0	-0.02	-5.0		-0.02	
Drain ON Leakage Current (Note 4)	I <sub>D(on)</sub>	V <sub>in</sub> = 0.8V	V <sub>S</sub> = 14V, V <sub>D</sub> = 14V		0.01	2.0	0.01		5.0	
			V <sub>S</sub> = 14V, V <sub>D</sub> = -14V		-2.0	-0.02	-5.0		-0.02	
<b>INPUT</b>										
Input Current with Input Voltage High	I <sub>NH</sub>	V <sub>in</sub> = 2.4V, V <sub>in</sub> = 15V	-1.0	0.0009			-1.0	0.0009	μA	
Input Current with Input Voltage Low	I <sub>NL</sub>	V <sub>in</sub> = 0V	-1.0	-0.0015			-1.0	-0.0015		
<b>DYNAMIC</b>										
Turn-ON Time	t <sub>on</sub>	See Switching Time Test Circuit (Figure 1)	440	1000			440	1000	ns	
Turn-OFF Time	t <sub>off</sub>		70	500			70	500		
Charge Injection	Q	C <sub>L</sub> = 1000pF, V <sub>GEN</sub> = 0V, R <sub>GEN</sub> = 0Ω (Figure 2)	10				10		pC	
Source OFF Capacitance	C <sub>S(off)</sub>	f = 140kHz V <sub>in</sub> = 5V or V <sub>S</sub> = 0V	V <sub>S</sub> = 0V		9.0		9.0		pF	
Drain OFF Capacitance	C <sub>D(off)</sub>		V <sub>D</sub> = 0V		9.0		9.0			
Channel ON Capacitance	C <sub>D(on)</sub> + C <sub>S(on)</sub>		V <sub>D</sub> = V <sub>S</sub> = 0V		25		25			
OFF Isolation Figure 3 (Note 5)		V <sub>in</sub> = 5V, Z <sub>L</sub> = 75Ω V <sub>S</sub> = 2.0V, f = 1MHz	75		75		75		dB	
Crosstalk Figure 4 (Channel to Channel)			90		90		90			

# Dual Monolithic SPST CMOS Analog Switch

DG200A

## ELECTRICAL CHARACTERISTICS (continued)

( $V^+ = +15V$ ,  $V^- = -15V$ , GND = 0V,  $T_A = 25^\circ C$ , unless otherwise indicated.)

PARAMETER	SYMBOL	TEST CONDITIONS	LIMITS				UNITS
			DG200A		DG200 B/C/D		
			MIN (Note 2)	TYP (Note 3)	MAX	MIN (Note 2)	
<b>SUPPLY</b>							
Positive Supply Current	I+	Both Channels ON or OFF $V_{in} = 0$ and 2.4V	180	300	200	500	$\mu A$
Negative Supply Current	I-		-10	-0.1	-100	-0.1	

## ELECTRICAL CHARACTERISTICS (Over Temperature)

( $V^+ = +15V$ ,  $V^- = -15V$ , GND = 0V,  $T_A =$  Over Temperature Range, unless otherwise indicated.)

PARAMETER	SYMBOL	TEST CONDITIONS	LIMITS				UNITS
			DG200A		DG200 B/C		
			MIN (Note 2)	TYP (Note 3)	MAX	MIN (Note 2)	
<b>SWITCH</b>							
Analog Signal Range (Note 1)	$V_{ANALOG}$		-15	15	-15	15	V
Drain-Source ON Resistance	$r_{DS(on)}$	$V_D = \pm 10V$ , $V_{in} = 0.8V$ , $I_S = 1mA$		100		100	$\Omega$
Source OFF Leakage Current	$I_{S(off)}$	$V_{in} = 2.4V$	$V_S = 14V$ , $V_D = -14V$	100		100	nA
			$V_S = -14V$ , $V_D = 14V$	-100		-100	
Drain OFF Leakage Current	$I_{D(off)}$	$V_{in} = 0.8V$	$V_S = -14V$ , $V_D = 14V$	100		100	
			$V_S = 14V$ , $V_D = -14V$	-100		-100	
Drain ON Leakage Current (Note 4)	$I_{D(on)}$		$V_S = V_D = 14V$	200		200	
			$V_S = V_D = -14V$	-200		-200	
<b>INPUT</b>							
Input Current/ Voltage High	$I_{NH}$	$V_{in} = 2.4V$ , $V_{in} = 15V$	-10		-10		$\mu A$
				10		10	
Input Current/ Voltage Low	$I_{INL}$	$V_{in} = 0V$	-10		-10		

**Note 1:** Signals on  $S_x$ ,  $D_x$ , or  $IN_x$ , exceeding  $V^-$  or  $V^+$  will be clamped by internal diodes. LIMIT FORWARD DIODE CURRENT to maximum current ratings.

**Note 2:** The algebraic convention whereby the most negative value is a minimum, and the most positive is a maximum, is used in this data sheet.

**Note 3:** Typical values are for DESIGN AID ONLY, not guaranteed nor subject to production testing.

**Note 4:**  $I_{D(on)}$  is leakage from driver into "ON" switch.

**Note 5:** "OFF" isolation =  $20 \log V_S/V_D$ ,  $V_S =$  input to OFF switch,  $V_D =$  output.

# Dual Monolithic SPST CMOS Analog Switch

## Test Circuits

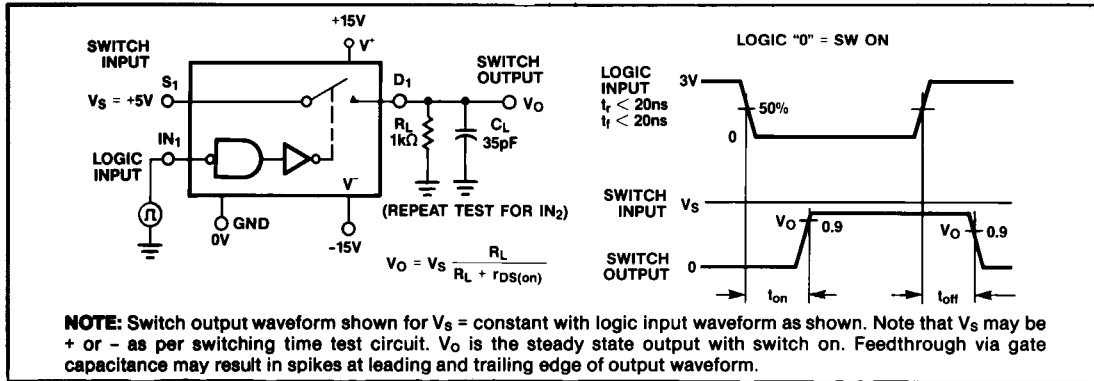

Figure 1. Switching Time Test Circuit

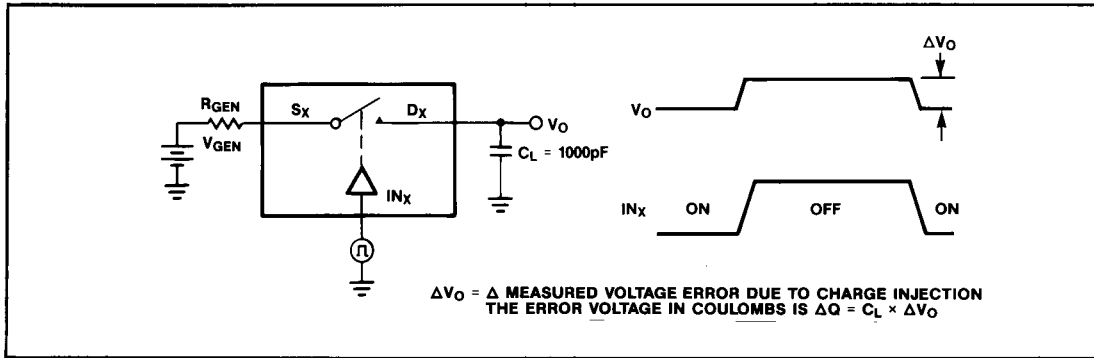

Figure 2. Charge Injection Test Circuit

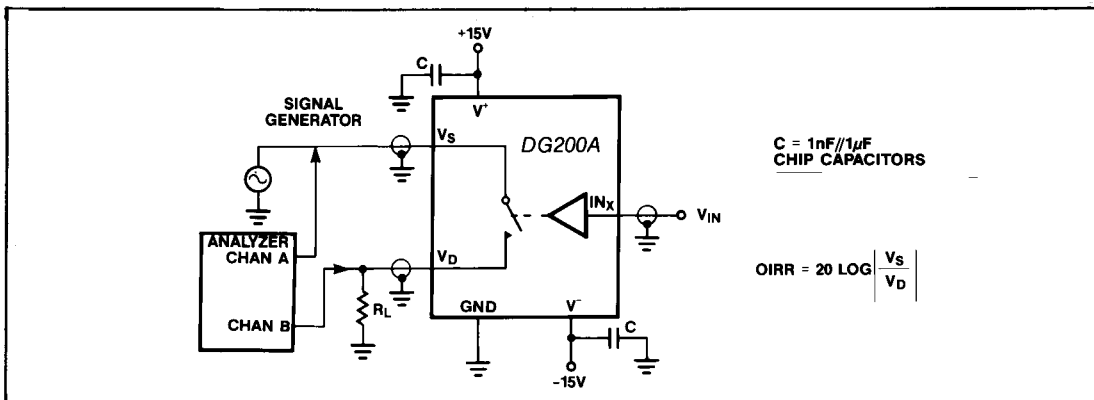

Figure 3. OFF Isolation Test Circuit

# Dual Monolithic SPST CMOS Analog Switch

Test Circuits (continued)

DG200A

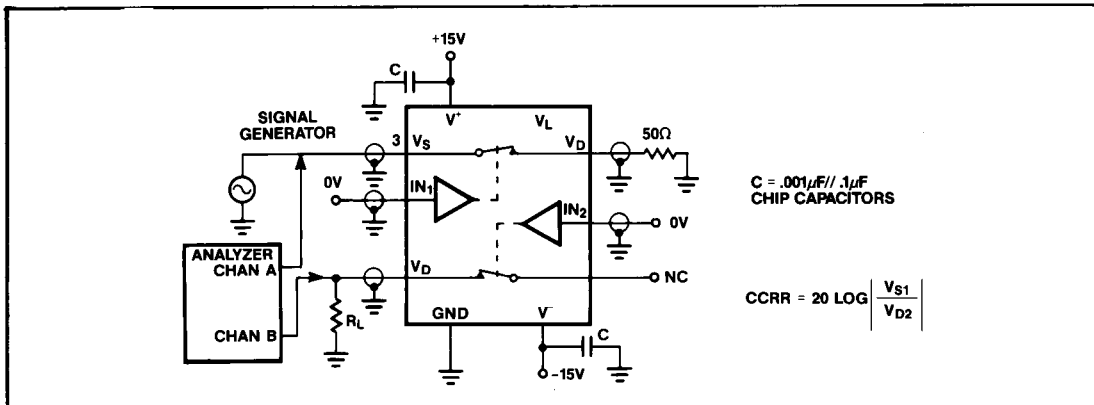
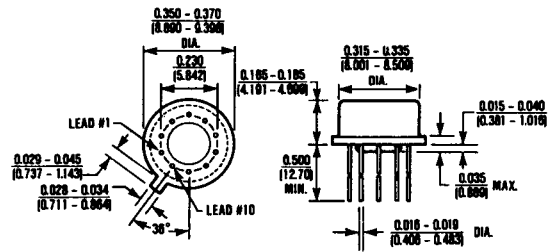
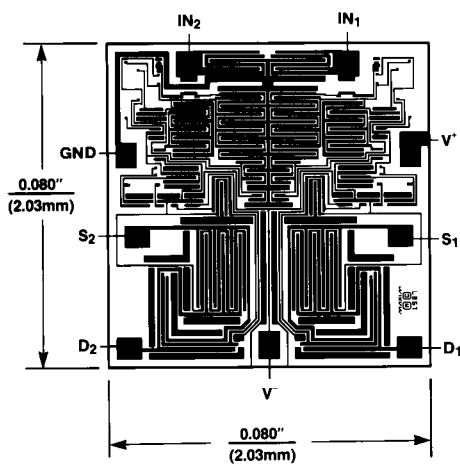

Figure 4. Channel To Channel Crosstalk Test Circuit

## Chip Topography

## Package Information



10 Lead TO-100 Can (TW)

$\theta_{JA} = 150^{\circ}\text{C/W}$

$\theta_{JC} = 45^{\circ}\text{C/W}$

# Dual Monolithic SPST CMOS Analog Switch

**DG200A**

## Package Information

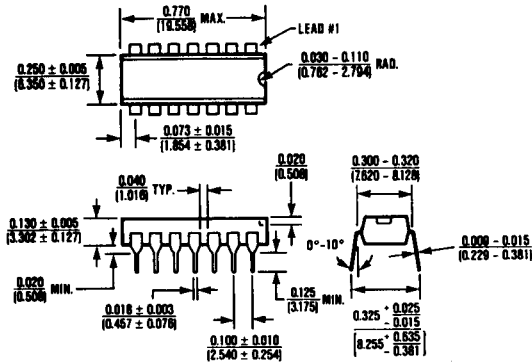

**14 Lead Plastic DIP (PD)**

$\theta_{JA} = 140^{\circ}\text{C/W}$   
 $\theta_{JC} = 70^{\circ}\text{C/W}$

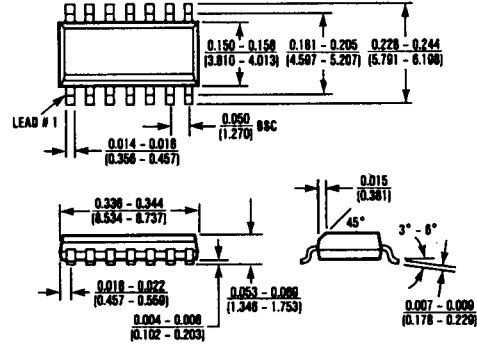

**14 Lead Small Outline (SD)**

$\theta_{JA} = 115^{\circ}\text{C/W}$   
 $\theta_{JC} = 60^{\circ}\text{C/W}$

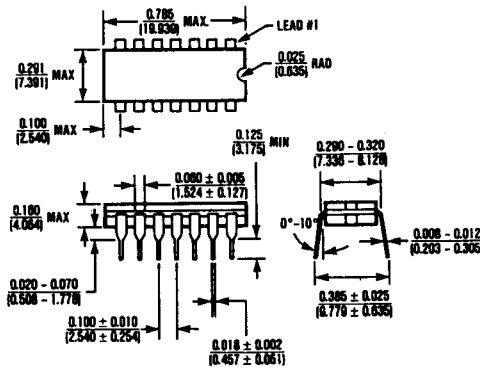

**14 Lead Cerdip (JD)**

$\theta_{JA} = 105^{\circ}\text{C/W}$   
 $\theta_{JC} = 50^{\circ}\text{C/W}$

Maxim cannot assume responsibility for use of any circuitry other than circuitry entirely embodied in a Maxim product. No circuit patent licenses are implied. Maxim reserves the right to change the circuitry and specifications without notice at any time.

6 Maxim Integrated Products, 120 San Gabriel Drive, Sunnyvale, CA 94086 (408) 737-7600

© 1996 Maxim Integrated Products

Printed USA

MAXIM is a registered trademark of Maxim Integrated Products.