

16384-word x 1-bit High Speed CMOS Static RAM

FEATURES

- Single +5V Supply and High Density 20 Pin Package
- Fast Access Time – 85ns/100ns
- Low Power Stand-by and Low Power Operation
Stand-by 100μW typ./5μW typ. (L-version)
and Operating 150mW typ.
- Completely Static Memory No Clock nor Refresh Required
- Fully TTL Compatible – All Inputs and Output
- Separate Data Input and Output Three State Output
- Pin-Out Compatible with Intel 2167 Series
- Capability of Battery Back Up Operation (L-version)

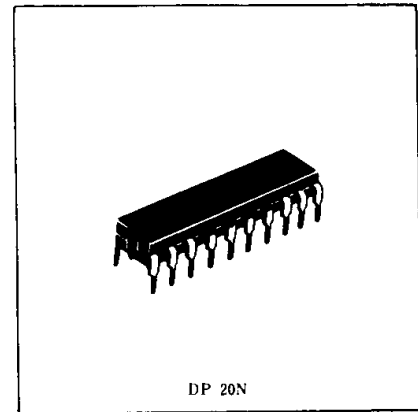

ORDERING INFORMATION

Type No.	Access Time	Package
HM6167P-6	85ns	300mil 20pin Plastic DIP
HM6167P-8	100ns	
HM6167LP-6	85ns	
HM6167LP-8	100ns	

BLOCK DIAGRAM

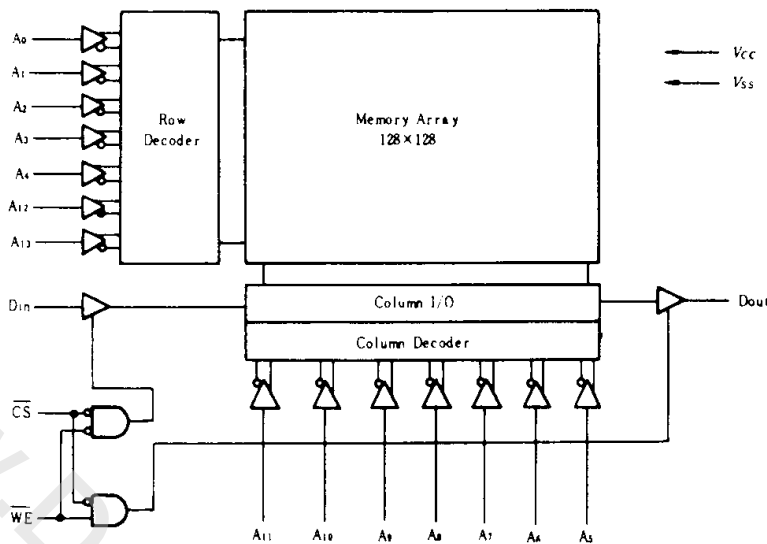

PIN ARRANGEMENT

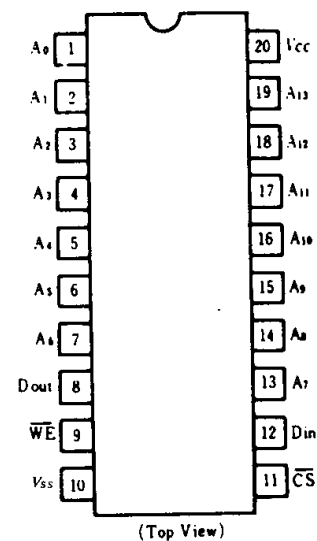

ABSOLUTE MAXIMUM RATINGS

Item	Symbol	Rating	Unit
Terminal Voltage with Respect to V _{SS}	V _T	-0.5*1 to +7.0	V
Power Dissipation	P _T	1.0	W
Operating Temperature	T _{OPR}	0 to +70	°C
Storage Temperature	T _{STG}	-55 to +125	°C
Storage Temperature under bias	T _{STG(bias)}	-10 to +85	°C

Note) *1. -3.5V for pulse width ≤ 20ns.



RECOMMENDED DC OPERATING CONDITIONS

($0^{\circ}\text{C} \leq T_a \leq 70^{\circ}\text{C}$)

Item	Symbol	min	typ	max	Unit
Supply Voltage	V_{CC}	4.5	5.0	5.5	V
	V_{SS}	0	0	0	V
Input High Voltage	V_{IH}	2.2	—	6.0	V
Input Low Voltage	V_{IL}	-0.3*1	—	0.8	V

Note) *1. -3.0V for pulse width $\leq 20\text{ns}$.

TRUTH TABLE

$\overline{\text{CS}}$	$\overline{\text{WE}}$	Mode	V_{CC} Current	Output Pin	Reference Cycle
H	x	Not Selected	I_{SB}, I_{SB1}	High Z	
L	H	Read	I_{CC}	Dout	Read Cycle 1, 2
L	L	Write	I_{CC}	High Z	Write Cycle 1, 2

DC AND OPERATING CHARACTERISTICS ($V_{CC}=5\text{V} \pm 10\%$, $T_a=0^{\circ}\text{C}$ to $+70^{\circ}\text{C}$)

Item	Symbol	Test Conditions	min	typ*1	max	Unit
Input Leakage Current	$ I_{LI} $	$V_{CC}=5.5\text{V}, V_{IN}=0\text{V} \sim V_{CC}$	—	—	2	μA
Output Leakage Current	$ I_{LO} $	$\overline{\text{CS}}=V_{IH}, V_{OUT}=0\text{V} \sim V_{CC}$	—	—	2	μA
Operating Power Supply Current	I_{CC}	$\overline{\text{CS}}=V_{IL}$, Output Open	—	30	60	mA
Standby Power Supply Current	I_{SB}	$\overline{\text{CS}}=V_{IH}$	—	5	20	mA
	I_{SB1}	$\overline{\text{CS}}=V_{CC}-0.2\text{V}$ $V_{IN} \leq 0.2\text{V}$ or $V_{IN} \geq V_{CC}-0.2\text{V}$	—	0.02	2	mA
Output Low Voltage	V_{OL}	$I_{OL}=8\text{mA}$	—	—	0.4	V
Output High Voltage	V_{OH}	$I_{OH}=-4\text{mA}$	2.4	—	—	V

Notes) *1. Typical limits are at $V_{CC}=5.0\text{V}$, $T_a=25^{\circ}\text{C}$ and specified loading.
*2. This characteristics is guaranteed only for L-version.

CAPACITANCE ($T_a=25^{\circ}\text{C}$, $f=1.0\text{MHz}$)

Item	Symbol	max	Unit	Conditions
Input Capacitance	C_{IN}	5	pF	$V_{IN}=0\text{V}$
Output Capacitance	C_{OUT}	6	pF	$V_{OUT}=0\text{V}$

Note) This parameter is sampled and not 100% tested.

AC CHARACTERISTICS ($V_{CC}=5\text{V} \pm 10\%$, $T_a=0$ to $+70^{\circ}\text{C}$, unless otherwise noted)

AC TEST CONDITIONS

Input pulse levels: V_{SS} to 3.0V
 Input rise and fall times: 5 ns
 Input timing reference levels: 1.5V
 Output reference levels: 1.5V
 Output load: See Figure

Output Load A

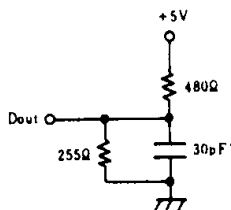

Output Load B

(for t_{HZ} , t_{LZ} , t_{wz} & t_{ow})

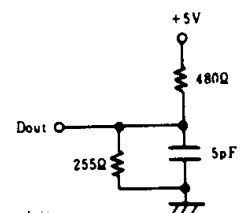

* Including scope and jig.



● READ CYCLE

Item	Symbol	HM6167-6		HM6167-8		Unit
		min	max	min	max	
Read Cycle Time	t_{RC}	85	—	100	—	ns
Address Access Time	t_{AA}	—	85	—	100	ns
Chip Select Access Time	t_{ACS}	—	85	—	100	ns
Output Hold from Address Change	t_{OH}	5	—	5	—	ns
Chip Selection to Output in Low Z	t_{LZ}	5	—	5	—	ns
Chip Deselection to Output in High Z	t_{HZ}	0	40	0	40	ns
Chip Selection to Power Up Time	t_{PU}	0	—	0	—	ns
Chip Deselection to Power Down Time	t_{PD}	—	40	—	45	ns

● WRITE CYCLE

Item	Symbol	HM6167-6		HM6167-8		Unit	Notes
		min	max	min	max		
Write Cycle Time	t_{WC}	85	—	100	—	ns	2
Chip Selection to End of Write	t_{CW}	65	—	80	—	ns	
Address Valid to End of Write	t_{AW}	65	—	80	—	ns	
Address Setup Time	t_{AS}	0	—	0	—	ns	
Write Pulse Width	t_{WP}	45	—	55	—	ns	
Write Recovery Time	t_{WR}	0	—	0	—	ns	
Data Valid to End of Write	t_{DW}	35	—	40	—	ns	
Data Hold Time	t_{DH}	0	—	0	—	ns	
Write Enable to Output in High Z	t_{WZ}	0	40	0	40	ns	3, 4
Output Active from End of Write	t_{OW}	0	—	0	—	ns	3, 4

- Notes) 1. If \overline{CS} goes high simultaneously with \overline{WE} high, the output remains in a high impedance state.
 2. All Write Cycle timings are referenced from the last valid address to the first transitioning address.
 3. Transition is measured $\pm 500mV$ from steady state voltage with specified loading in Load B.
 4. This parameter is sampled and not 100% tested.

● TIMING WAVEFORM OF READ CYCLE NO.1¹⁾

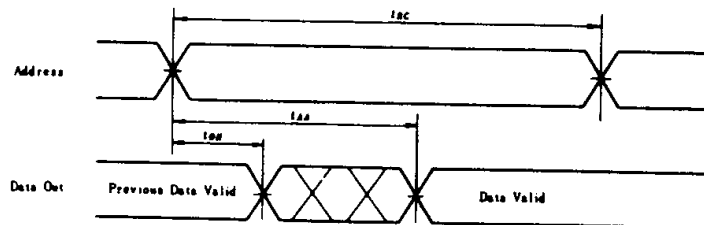

●TIMING WAVEFORM OF READ CYCLE NO.2 ^{1), 3)}

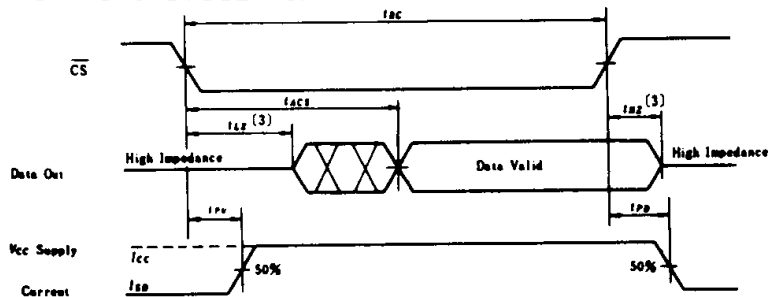

- NOTES: 1. \overline{WE} is high and \overline{CS} is low for READ cycle.
 2. Addresses valid prior to or coincident with \overline{CS} transition low.
 3. Transition is measured $\pm 500\text{mV}$ from steady state voltage with specified loading in Load B.

●TIMING WAVEFORM OF WRITE CYCLE NO.1 (\overline{WE} Controlled)

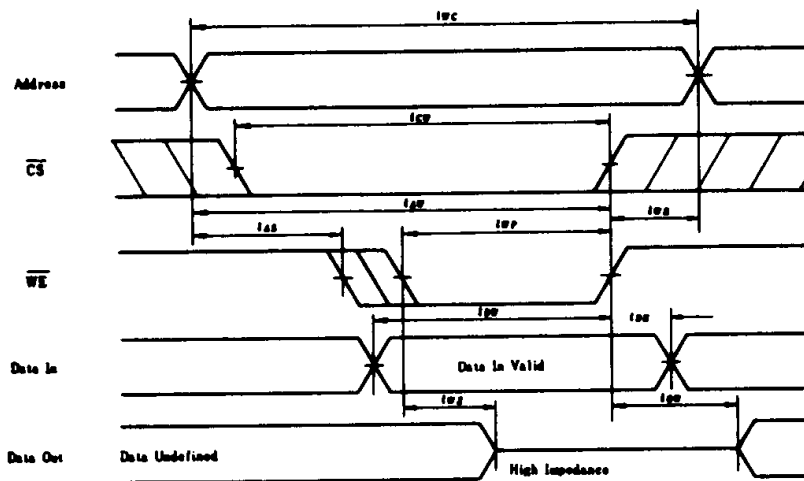

●TIMING WAVEFORM OF WRITE CYCLE No. 2 (\overline{CS} Controlled)

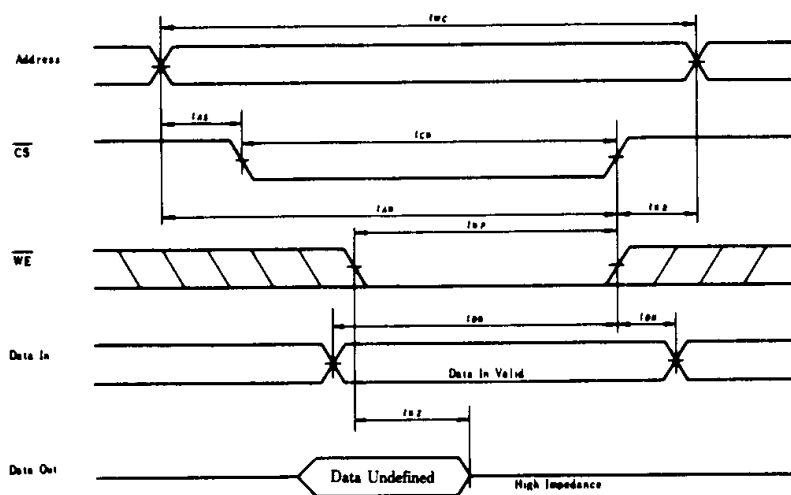

■ LOW V_{CC} DATA RETENTION CHARACTERISTICS (T_a=0°C to +70°C)

This characteristics is guaranteed only for L-version.

Parameter	Symbol	Test Condition	min	typ	max	Unit
V _{CC} for Data Retention	V _{DR}	$\overline{CS} \geq V_{CC} - 0.2V$ $V_{i} \geq V_{CC} - 0.2V$ or $0V \leq V_{i} \leq 0.2V$	2.0	—	—	V
Data Retention Current	I _{CCDR}		—	—	20*2	μA
Chip Deselect to Data Retention Time	t _{CDR}		0	—	—	
Operation Recovery Time	t _R		t _{RC} *1	—	—	ns

Notes) *1. t_{RC}—Read Cycle Time *2. V_{CC}=2.0V
 *3. V_{CC}=3.0V

● LOW V_{CC} DATA RETENTION WAVEFORM

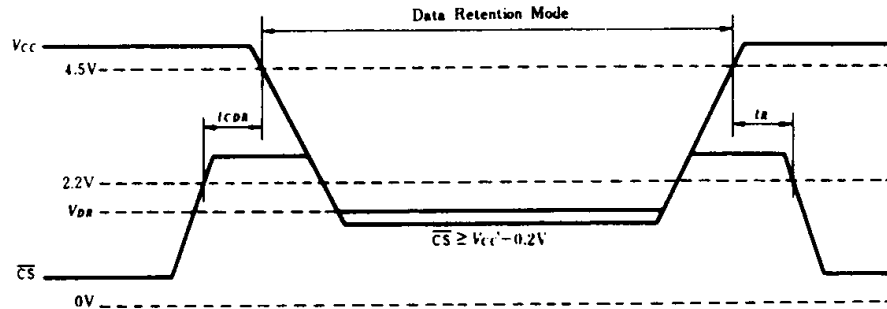

SUPPLY CURRENT vs. SUPPLY VOLTAGE

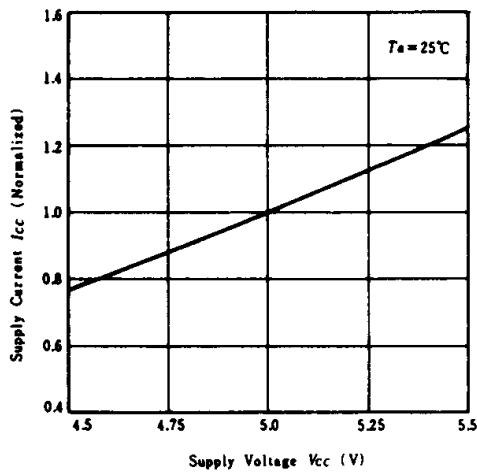

SUPPLY CURRENT vs. AMBIENT TEMPERATURE

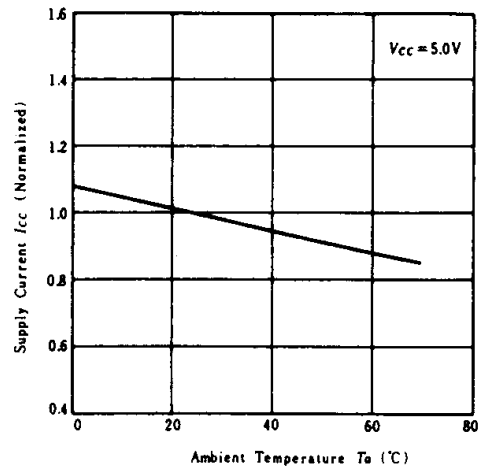

ACCESS TIME vs. SUPPLY VOLTAGE

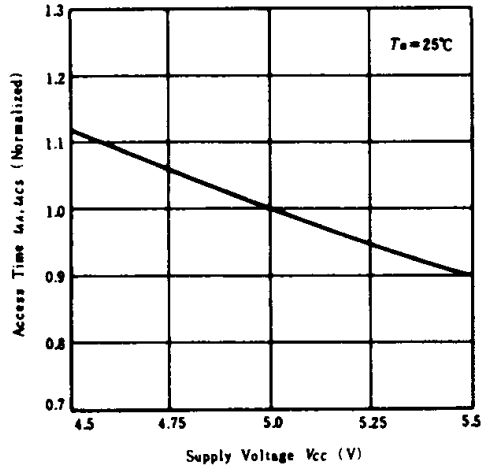

ACCESS TIME vs. AMBIENT TEMPERATURE

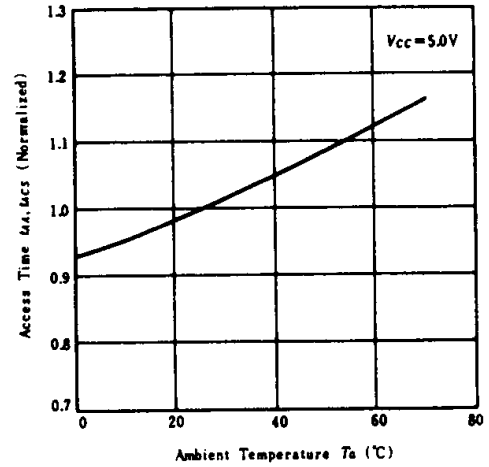

ACCESS TIME vs. LOAD CAPACITANCE

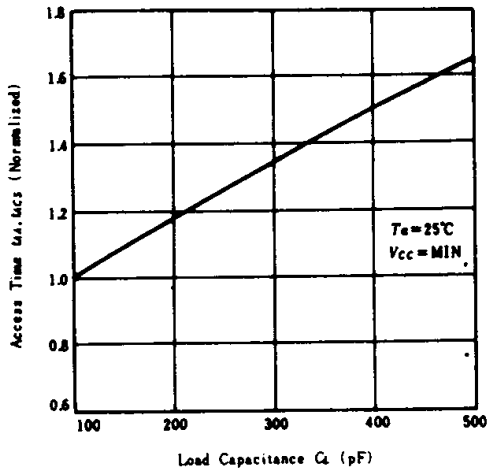

SUPPLY CURRENT vs. FREQUENCY

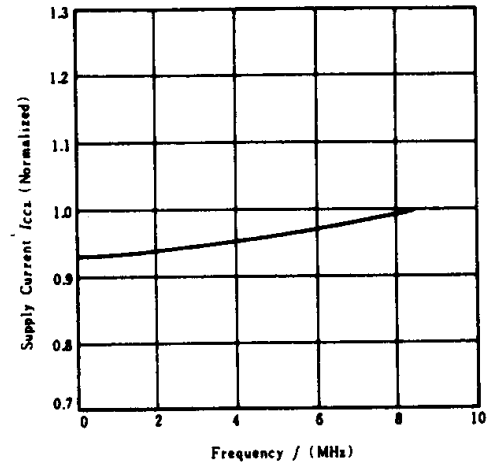

INPUT LOW VOLTAGE vs. SUPPLY VOLTAGE

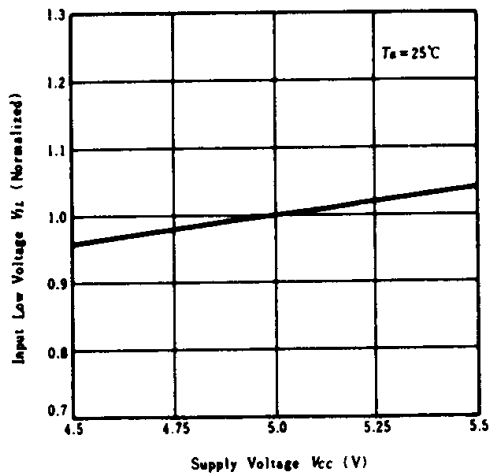

INPUT HIGH VOLTAGE vs. SUPPLY VOLTAGE

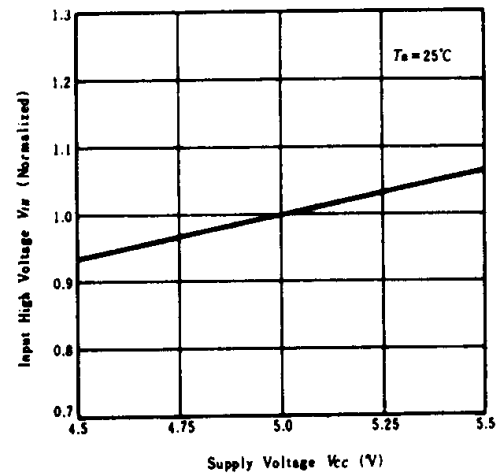

OUTPUT HIGH CURRENT vs. OUTPUT HIGH VOLTAGE

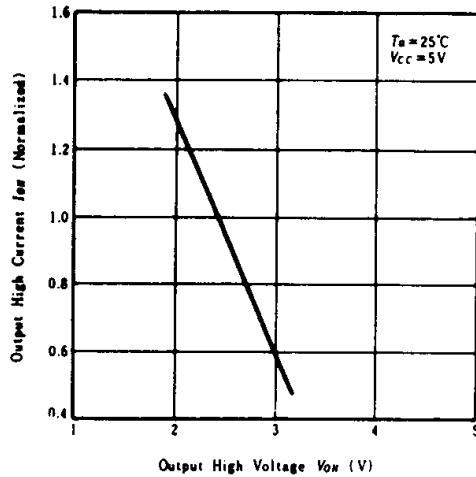

OUTPUT LOW CURRENT vs. OUTPUT LOW VOLTAGE

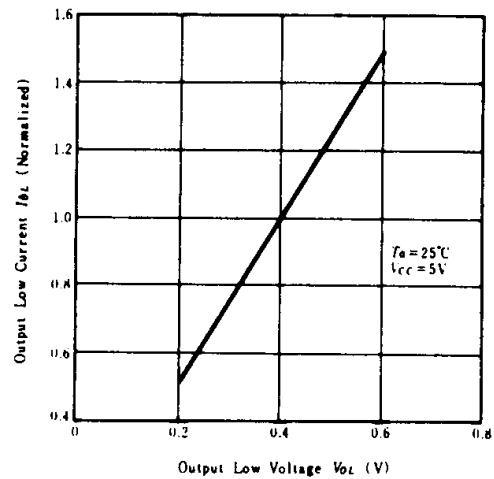

STANDBY CURRENT vs. AMBIENT TEMPERATURE

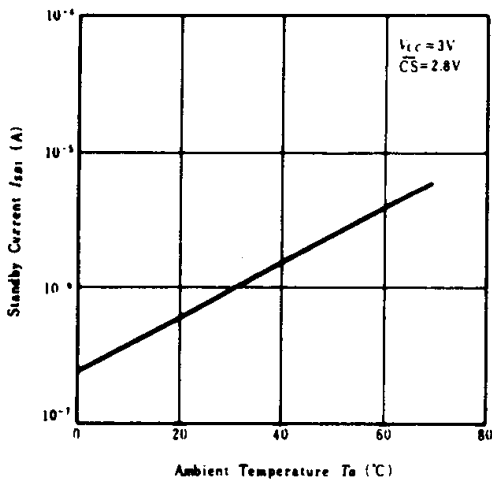

STANDBY CURRENT vs. SUPPLY VOLTAGE

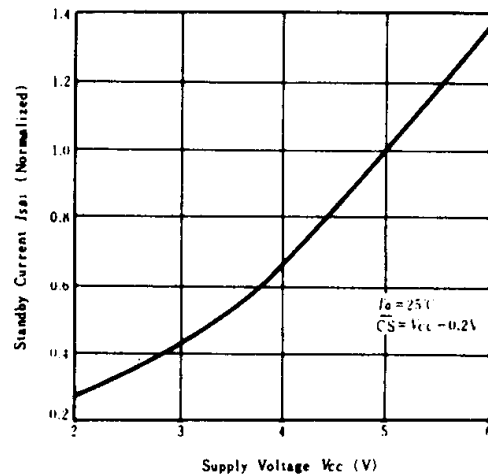

STANDBY CURRENT vs. INPUT VOLTAGE

