



SANYO Semiconductors

# DATA SHEET

## LA72670BM — Monolithic Linear IC US multiplex modulation for VCR HiFi Sound Signal Processor

### Overview

The LA72670BM is a HiFi sound signal processor with a built-in US multiplex modulation for VCR.

### Functions

- US multiplex modulation
- HiFi sound signal processor

### Specifications

Maximum Ratings at Ta = 25°C

Parameter	Symbol	Conditions	Ratings	Unit
Maximum power supply voltage 1	V <sub>CC</sub> H max		9.6	V
Maximum power supply voltage 2	V <sub>CC</sub> L max		6	V
Always power supply voltage	V <sub>CCA</sub> max		6	V
Allowable power dissipation	Pd max	Ta=70°C *	1300	mW
Operating ambient temperature	Topr		-10 to +70	°C
Storage ambient temperature	Tstg		-55 to +150	°C

\* On board: 114.3mm×76.1mm×1.6mm, glass epoxy board.

■ Any and all SANYO Semiconductor Co.,Ltd. products described or contained herein are, with regard to "standard application", intended for the use as general electronics equipment (home appliances, AV equipment, communication device, office equipment, industrial equipment etc.). The products mentioned herein shall not be intended for use for any "special application" (medical equipment whose purpose is to sustain life, aerospace instrument, nuclear control device, burning appliances, transportation machine, traffic signal system, safety equipment etc.) that shall require extremely high level of reliability and can directly threaten human lives in case of failure or malfunction of the product or may cause harm to human bodies, nor shall they grant any guarantee thereof. If you should intend to use our products for applications outside the standard applications of our customer who is considering such use and/or outside the scope of our intended standard applications, please consult with us prior to the intended use. If there is no consultation or inquiry before the intended use, our customer shall be solely responsible for the use.

■ Specifications of any and all SANYO Semiconductor Co.,Ltd. products described or contained herein stipulate the performance, characteristics, and functions of the described products in the independent state, and are not guarantees of the performance, characteristics, and functions of the described products as mounted in the customer's products or equipment. To verify symptoms and states that cannot be evaluated in an independent device, the customer should always evaluate and test devices mounted in the customer's products or equipment.

**SANYO Semiconductor Co., Ltd.**

TOKYO OFFICE Tokyo Bldg., 1-10, 1 Chome, Ueno, Taito-ku, TOKYO, 110-8534 JAPAN

40507 MS PC B8-7419 No.A0644-1/20

# LA72670BM

## Operating Conditions at Ta = 25°C

Parameter	Symbol	Conditions	Ratings	Unit
Recommended operating voltage 1	V <sub>CC</sub> H		9	V
Recommended operating voltage 2	V <sub>CC</sub> L		5	V
Recommended always voltage	V <sub>CC</sub> A		5	V
Allowable operating voltage 1	V <sub>CC</sub> H op1		8.5 to 9.5	V
Allowable operating voltage 2	V <sub>CC</sub> L op2		4.8 to 5.3	V
Allowable operating always voltage	V <sub>CC</sub> A op3		4.5 to 5.5	V

## Electrical Characteristics at Ta = 25°C, V<sub>CC</sub>H=9V, V<sub>CC</sub>L=5V, V<sub>CC</sub>A=5V

Parameter	Symbol	Conditions	Ratings			Unit
			min	typ	max	
Current dissipation REC&EE 9V	I <sub>CC</sub> R1	No signal, Inflow current at Pin 3/54 G1D8D7:00		57	65	mA
Current dissipation EE 5V	I <sub>CC</sub> E1	No signal, Inflow current at Pin 15/32/36/46 G1D8D7:00		72	84	mA
Current dissipation REC 5V	I <sub>CC</sub> R2	No signal, Inflow current at Pin 15/32/36/46 G1D8D7:00, G1D4:1		100	115	mA
Current dissipation PB 9V	I <sub>CC</sub> P1	No signal, Inflow current at Pin 3/54 G1D8D7:01		11	13	mA
Current dissipation PB 5V	I <sub>CC</sub> P2	No signal, Inflow current at Pin 15/32/36/46 G1D8D7:01		85	97	mA
Current dissipation always power supply	I <sub>CC</sub> AL	No signal, Inflow current at Pin 5, Mute H at Pin 49		1.6	2	mA
[EE through] (LINE IN (EXT1,2,3) to LINE OUT), EE mode, f=1kHz, L/R-ch						
Output level 1	V <sub>O</sub> 1	V <sub>IN</sub> =-28.2dBV, Gain1 (G3 D4:0)	-7.5	-9	-10.5	dBV
Output level 2	V <sub>O</sub> 2	V <sub>IN</sub> =-28.2dBV, Gain2 (G3 D4:1)	-6.5	-8	-9.5	dBV
Output distortion	THD	V <sub>IN</sub> =-28.2dBV, Gain1, 2		0.05	0.15	%
Channel gain difference	ΔV <sub>O</sub>	V <sub>IN</sub> =-28.2dBV, Gain1, 2	-1	0	1	dB
Maximum output level	V <sub>O</sub> M	THD=1%, Gain1, 2	7	8.5		dBV
Output noise level	V <sub>N</sub> O	Rg=1kΩ, JIS-A filter, Gain1		-89	-85	dBV
Mute attenuation value	MU	V <sub>IN</sub> =-18.2dBV		-91	-80	dB
Input switch cross-talk	CT	V <sub>IN</sub> =-18.2dBV		-75	-68	dB
[Normal output] (LINE IN(EXT1/2/3) to NORMAL OUT(Pin 6)), EE mode, f=1kHz, G1D8D7:00						
Output level for Normal	V <sub>O</sub> NOR	V <sub>IN</sub> =-28.2dBV	-22	-21	-20	dBV
[BS through] (BS, IN to LINE OUT), f=1kHz, G2D6:1						
Output level	V <sub>O</sub> TH	V <sub>IN</sub> =-21.2dBV, Gain1 (G3D4:0)	-10.5	-9	-7.5	dBV
[RFC output] (NORMAL IN to RFC OUT), f=1kHz, G2D3D4:10, G4D7:0						
Output level	V <sub>O</sub> R	V <sub>IN</sub> =-21.2dBV, G4D2:0	-11.0	-9.5	-8.0	dBV
Output distortion	THDR	V <sub>IN</sub> =-21.2dBV, G4D2:0		0.05	0.2	%
ALC level (1)	V <sub>O</sub> AR1	V <sub>IN</sub> =-11.2dBV, G4D2:0	-7.0	-5.5	-4.0	dBv
ALC distortion (1)	THDAR1	V <sub>IN</sub> =-11.2dBV, G4D2:0		0.3	0.5	%
ALC level (2)	V <sub>O</sub> AR2	V <sub>IN</sub> =-11.2dBV, G4D2:1	-3.0	-1.5	0	dBv
ALC distortion (2)	THDAR2	V <sub>IN</sub> =-11.2dBV, G4D2:1		0.3	0.5	%
[LINE AMP] (NORMAL IN to LINE OUT), EE mode, f=1kHz, Left channel and Right channel, G2D4D3:10						
Line amp gain	GVL	Gain1 mode, V <sub>IN</sub> =-21dBV	11	12	13	dB
[REC system] (LINE IN to VCO OUT), f=1kHz, G1D4:1(REC_MODE), G1D3D2:01(EXT1), G3D8:0(NTSC), G4D5D6:00						
Free-running frequency L	f <sub>O</sub> L	Input no signal	1.294	1.300	1.306	MHz
Free-running frequency R	f <sub>O</sub> R	Input no signal	1.694	1.700	1.706	MHz
Standard frequency deviation L&R	DEV	V <sub>IN</sub> =-28.2dBV	±46	±50	±54	kHz
Carrier output level Lch	V <sub>f</sub> oL	Non modulation	450	500	550	mVp-p

Continued on next page.

# LA72670BM

Continued from preceding page.

Parameter	Symbol	Conditions	Ratings			Unit
			min	typ	max	
FM R/Lch MIX ratio 1	MIX1	Non modulation, VfoR/VfoL, P23:OV,P34.Measure, G3D7D6;01	7.1	7.6	8.1	dB
FM R/Lch MIX ratio 2	MIX2	Non modulation, VfoR/VfoL, P23:OV,P34.Measure, G3D7D6;00	8.1	8.6	9.1	dB
FM R/Lch MIX ratio 3	MIX3	Non modulation, VfoR/VfoL, P23:OV,P34.Measure, G3D7D6;10	9.1	9.6	10.1	dB
FM R/Lch MIX ratio 4	MIX4	Non modulation, VfoR/VfoL, P23:OV, P34.Measure, G3D7D6;11	10.1	10.6	11.1	dB
Carrier 2nd high frequency	2HD	Non modulation, To each basic frequency.		-48	-34	dB
Carrier 3rd high frequency	3HD	Non modulation, To each basic frequency.		-43	-34	dB
REC current	I <sub>OR</sub>	P23:0V, Inflow current at P26, with current probe	34	37	40	mAp-p
Cross modulation distortion 0.4M component	CMDO4	P23:0V, Compare 0.4MHz with Rch Carrier Level		-48	-40	dB
modulation distortion 0.9M component	CMDO9	P23:0V, Compare 0.9MHz with Rch Carrier Level		-55	-40	dB
current ratio -1.5dB	I <sub>OR</sub> -1.5dB	P23:0V G4D6D5:01(-1.5dB)	-2.3	-1.3	-0.3	dB
current ratio -5.5dB	I <sub>OR</sub> -5.5dB	P23:0V G4D6D5:10(-5.5dB)	-6.8	-5.8	-4.8	dB
MUTE attenuation value	I <sub>ORMU</sub>	REC MUTE ON(Pin 17=H)			-40	dB
[FM modulation system] (PB FM IN to LINE OUT), PB mode(G1D8D7:01), FM standard input=300mVp-p(R/Lch ratio=1:1)						
Output level Lch	V <sub>OPL</sub>	fc=1.3±50kHz, fm=1kHz,G=1	-11	-9	-7	dBV
Output level Rch	V <sub>OPR</sub>	fc=1.7MHz±50kHz, fm=1kHz,G=1	-11	-9	-7	dBV
Output level difference	VDEM	fc=1.3MHz±50kHz, fm=1kHz fc=1.7MHz±50kHz, fm=1kHz Lch-Rch	-1.5	0	1.5	dB
Output distortion Lch	THDPL	fc=1.3MHz±50kHz, fm=1kHz,DIN		0.3	0.5	%
Output distortion Rch	THDPR	fc=1.7MHz±50kHz, fm=1kHz, DIN		0.3	0.5	%
[DO detector / HiFi detector] PB mode(DO DET : fc=1.3MHz / HiFi DET : fc=1.7MHz), G1D8D7:01						
DO detection level	DOC	The ratio with Standard input 300mVp-p		-26	-23	dB
DO detection hysteresis	DOCH		0.5	3	5	dB
HiFi recovery delay time	HIDEL	The delay time that is changed from NORMAL to HiFi.	110	125	140	ms
HiFi detection DC output 1	VTRS1	Pin 34 INPUT_Level=100mVp-p, 1.3MHz	2.1	2.6	3.1	V
HiFi detection DC output 2	VTRS2	Pin 34 INPUT_Level=300mVp-p, 1.3MHz	3.3	3.8	4.3	V
HiFi detection DC output 3	VTRS3	Pin 34 INPUT_Level=1Vp-p, 1.3MHz	4.3	4.8	5.3	V
NORMAL detection DC output	NORDC	Pin 34 INPUT_Level=0mVp-p			0.4	V
[Hold pulse occurrence] PB mode, G1D8D7:01						
Hold pulse delay time	HPD	AUDIO HEAD PULSE IN	0.8	1.0	1.2	μs
Hold pulse width	HPW	AUDIO HEAD PULSE IN	7.0	8.3	9.5	μs
[Band pass filter] PB mode, PB IN = 150mVp-p(R/L MIX ratio 1:1)at Pin 31, Pin 17;2.5V, G1D8D7:01,						
1.3MHz BPF monitor level	V13	G2D2D1;01	80	105	130	mVp-p
1.7MHz BPF monitor level	V17	G2D2D1;10	65	90	115	mVp-p
1.3MHz BPF frequency characteristics 1	L115N	Level difference between 1.15M/1.3MHz G2D2D1;01	-9	-3		dB
1.3MHz BPF frequency characteristics 2	L145N	Level difference between 1.45M/1.3MHz G2D2D1;01	-18	-8		dB
1.3MHz BPF frequency characteristics 3	L155N	Level difference between 1.55M/1.3MHz G2D2D1;01		-27	-9	dB
1.7MHz BPF frequency characteristics 1	R145N	Level difference between 1.45M/1.7MHz G2D2D1;10		-18	-8	dB
1.7MHz BPF frequency characteristics 2	R155N	Level difference between 1.55M/1.7MHz G2D2D1;10	-9	-3		dB
1.7MHz BPF frequency characteristics 3	R185N	Level difference between 1.85M/1.7MHz G2D2D1;10	-12	-2		dB

Continued on next page.

# LA72670BM

Continued from preceding page.

Parameter	Symbol	Conditions	Ratings			Unit
			min	typ	max	
[Playback head amp system] (PB HEAD AMP IN to OUT), PB mode, G1D8D7;01						
Voltage gain	GVP	$V_{IN}=100\mu\text{Vp-p}$ , $f=1.5\text{MHz}$ , CH1&2	69	72	75	dB
Voltage gain difference CH1/CH2	$\Delta\text{GVP}$		-2	0	2	dB
EP gain boost value	$\Delta\text{GEP}$	$V_{IN}=100\mu\text{Vp-p}$ , $f=1.5\text{MHz}$	1	2	3.2	dB
Frequency characteristics	$\Delta\text{fP}$	$V_{IN}=100\mu\text{Vp-p}$ , $f=1.8\text{M}/1.0\text{MHz}$ , CH1&2	-3	-1	1	dB
Input conversion noise voltage	VNINP	The value(1 / GVP) of 1.1MHz LPF output level		1.7	2	$\mu\text{Rms}$
Output DC offset	$\Delta\text{V}_{\text{O}DC}$	CH1/CH2	-30	0	30	mV
[SIF system] (SIF IN to SIF OUT), EE/REC mode						
Input level	$V_{\text{I}LIM}$	$f_c=4.5\text{MHz}$	80	90	100	$\text{dB}\mu\text{V}$
Output level	$V_{\text{O}SI}$	$f_c=4.5\text{MHz}\pm 25\text{kHz}$ , $f_m=1\text{kHz}$	420	530	660	mVp-p
Distortion	THDSI	MONO 1kHz 100% modulation		0.3	0.8	dB
S/N	SNSI	75 $\mu$ De-emphasis	57	62		dB
[TV multiplex demodulation system] (BASE-BAND IN to LINE OUT), EE/REC mode, L/Rch, LINE AMP GAIN(1) Deviation of SIF input MONO: 300Hz 100% $\rightarrow$ $\pm 25\text{kHz}$						
MONO output level	$V_{\text{O}MN}$	$f_m=1\text{kHz}$ , 100% modulation, Pre-em.ON	-8.5	-7	-5.5	dBV
Output L/R level difference	$\Delta\text{V}_{\text{O}MN}$	$f_m=1\text{kHz}$ , 100% modulation, Pre-em.ON	-1.5	0	1.5	dB
MONO distortion	THDM	$f_m=1\text{kHz}$ , 100% modulation, Pre-em.ON		0.15	0.6	%
MONO frequency characteristics 1	FCM1	$f_m=8\text{kHz}$ , 30% modulation, Pre-em.ON	-2	0	2	dB
MONO S/N	SNM	$S=V_{\text{O}MN}$ , N=0% modulation, 15kHz LPF+JIS-A	57	62		dB
STEREO output level	$V_{\text{O}ST}$	$f_m=1\text{kHz}$ , 100% modulation, 15kHz LPF	-9	-7	-5	dBV
STEREO distortion	THDS	$f_m=1\text{kHz}$ , 100% modulation, 15kHz LPF		1.0	2.5	%
STEREO S/N	SNS	$S=V_{\text{O}ST}$ , N=0% modulation, 15kHz LPF+JIS-A	50			dB
STEREO separation	STSE1	$f=300\text{Hz(R/L)}$ , 30% modulation, 15kHz LPF	20	25		dB
STEREO separation2	STSE2	$f=3\text{kHz(R/L)}$ , 30% modulation, 15kHz LPF	20	25		dB
Input Pilot level1 for STEREO detection	$V_{\text{I}NSD}$	Pilot( $f_H$ )=15.73kHz, 100%=110 mVp-p		40		%
Input Pilot level1 hysteresis for STEREO detection	HYST	Pilot( $f_H$ )=15.73kHz, 0dB= $V_{\text{I}NSD}$		3		dB
Stereo VCO free-running frequency	FSTVCO	No signal, the monitor output of Pin 51 is measured.	60.0	63	66.8	kHz
SAP output level	$V_{\text{O}SA}$	$f_m=1\text{kHz}$ , 100% modulation, 15kHz LPF	-10	-7	-4	dBV
SAP distortion	THDSA	$f_m=1\text{kHz}$ , 100% modulation, 15kHz LPF 2nd+3rd harmonic distortion, 15kHz LPF		1.5	3.5	%
SAP S/N	SNSA	$S=V_{\text{O}SA}$ , 100% modulation, 15kHz LPF+JIS-A	55	65		dB
SAP detection input level	$V_{\text{I}NSA}$	SAP Carrier=5fH, 0dB=300 mVp-p	-26	-20	-15	dB
SAP detection hysteresis	HYSA	SAP Carrier=5fH		3		dB
MODE output MONO	LEDMO	MONO: $f=1\text{kHz}$ , 0% modulation		1.0	1.3	V
MODE output SAP	LEDSA	SAP:Carrier	1.7	2.0	2.3	V
MODE output STEREO	LEDST	STEREO:Pilot	2.7	3.0	3.3	V
MODE output ST+SAP	LEDSS	STEREO:Pilot, SAP:Carrier	3.5	3.8	4.2	V
[Control hold voltage]						
CLOCK Low voltage	VCL		0		1	V
CLOCK High voltage	VCH		2.5		$V_{CC2}$	V
DATA Low voltage	VDL		0		1	V
DATA High voltage	VDH		2.5		$V_{CC2}$	V
MUTE ON voltage	MON		3.0		$V_{CC2}$	V
MUTE OFF voltage	MOFF		0		1.0	V
REC MUTE ON voltage	RMON		3.0		$V_{CC2}$	V
REC MUTE OFF voltage	RMOFF		0		1.0	V

Package Dimensions

unit : mm (typ)  
5255

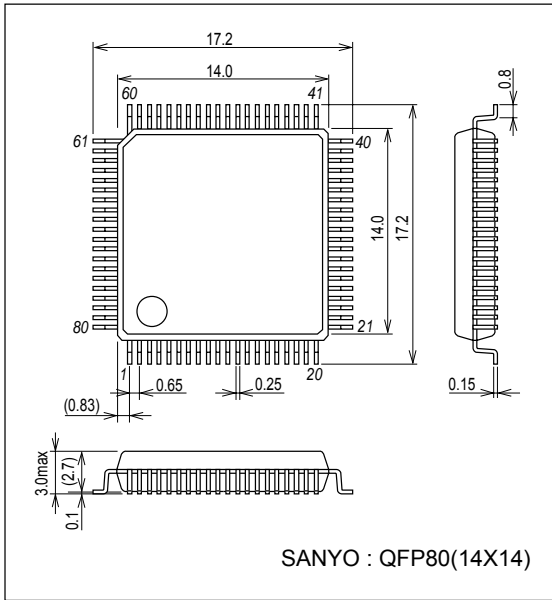

Block Diagram

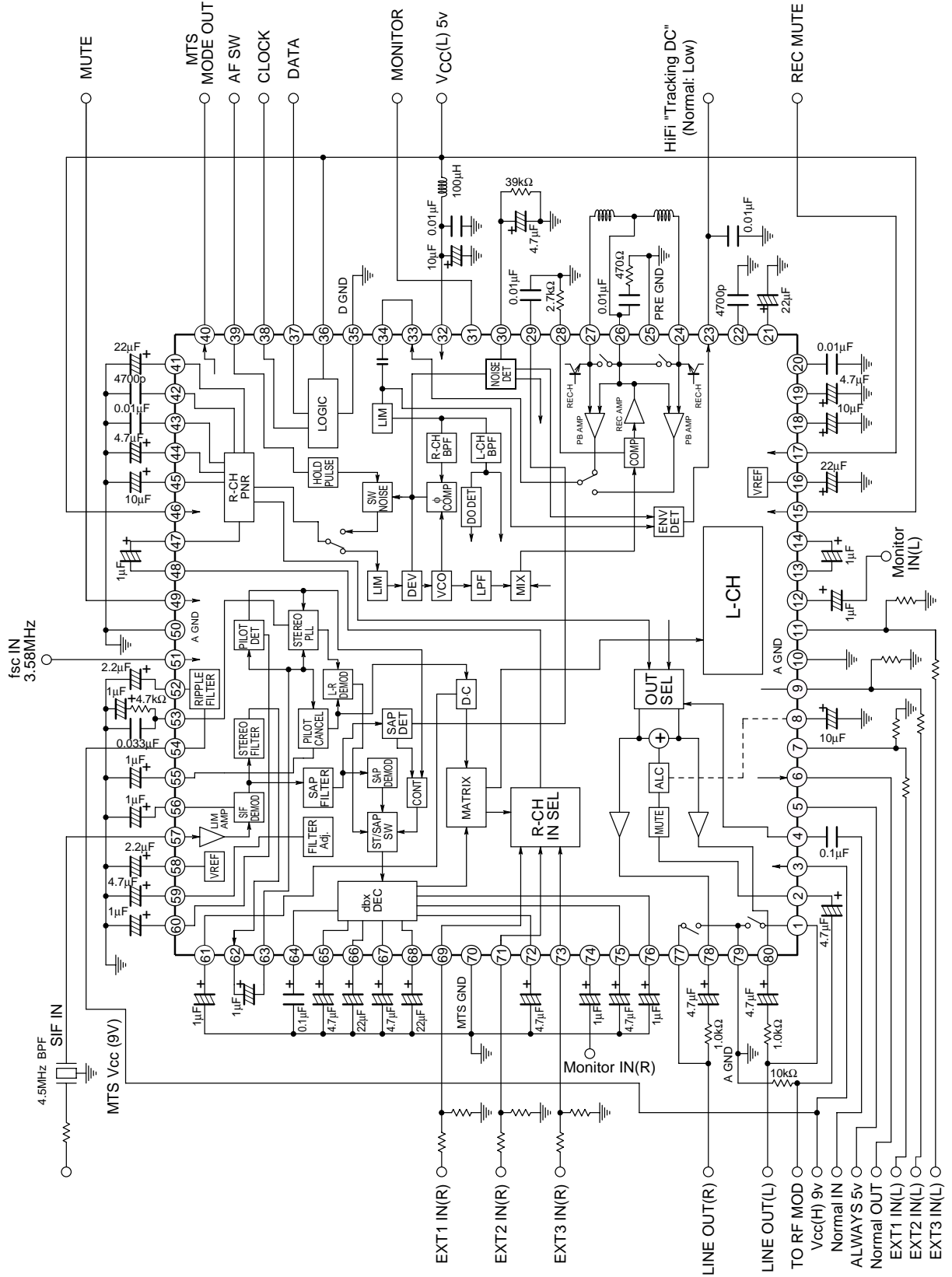

# LA72670BM

## Pin Description

Pin No.	Pin Function Name	DC voltage	Function	Equivalent circuit
		AC level		
1 77	Line Mute terminal(L) Line Mute terminal(R)		When the power supply $V_{CC}$ is on, the switch of Pin 77 and Pin 1 is turned ON to reduce the line out noise. In this case, it is necessary to apply 5 fixed DC to Pin 5.	
2	Output terminal for RF modulator	DC; 4.2V AC; -9.5dBV	Output terminal for RF modulator. ALC level can be settled to -1dBV and -5dBV by serial control.	
3	$V_{CC}$ 9V		Power supply of Line Out.	
5	ALWAYS $V_{CC}$		Power supply for the noise elimination mute control when power is on.	
15	$V_{CC}$ 5V(Lch)		5V power supply of Lch.	
32	$V_{CC}$ 5V		5V power supply of HEAD AMP.	
36	Power supply for Logic		Power supply for Logic.	
46	$V_{CC}$ 5V(Rch)		5V power supply of Rch.	
54	9V power supply for MTS		9V power supply of MTS.	
4	NORMAL input terminal	DC; 2.5V AC; -21.2dBV	NORMAL IC output signal is entered and output to Line Out through output changeover. G4D7/0:0dB 1:3dB	
6	NORMAL output terminal	DC; 2.5V AC; -21.2dBv	This is connected to input of NORMAL AUDIO IC.	
7 9 11 69 71 73	Audio input terminal EXT1_IN(L) EXT2_IN(L) EXT3_IN(L) EXT1_IN(R) EXT2_IN(R) EXT3_IN(R)	DC ; 0V AC; -28.2dBV	Audio input terminal.	

Continued on next page.

# LA72670BM

Continued from preceding page.

Pin No.	Pin Function Name	DC voltage	Function	Equivalent circuit
		AC level		
8	ALC detection terminal for RF converter	DC;	This is ALC detector terminal for RF converter and always ready for operation.	
10 25 35 50 70 79	L-GND HEADAMP-GND LOGIC-GND R-GND MTS-GND AUDIO-GND			
12  74	BS monitor input terminal(L)  BS monitor input terminal(R)	DC ; 2.5V	BS monitor input terminal	
13  48	Input changeover switch output(L)  Input changeover switch output(L)	DC ; 2.5V	PB/REC switch output to transform REC and PB signals into DC through a coupling capacitor.	
14  47	HiFi input terminal(L)  HiFi input terminal(R)	DC ; 2.5V	HiFi input terminal after passing through a coupling capacitor.	
16	1/2 V <sub>CC</sub> terminal	DC; 2.5V	1/2 V <sub>CC</sub> terminal.  Serially-set reset is made with the external capacitance C and internal resistance R (15kΩ) at rise of power supply. The reset time t is expressed as follows: $t = -CR \ln(0.2)$	

Continued on next page.



# LA72670BM

Continued from preceding page.

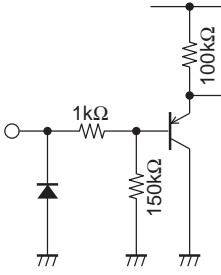
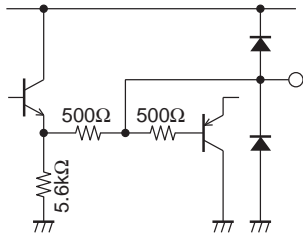
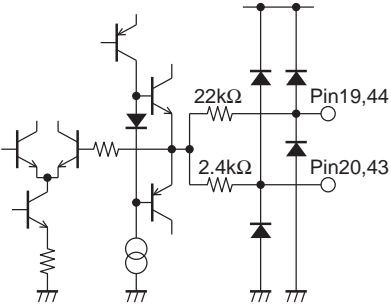
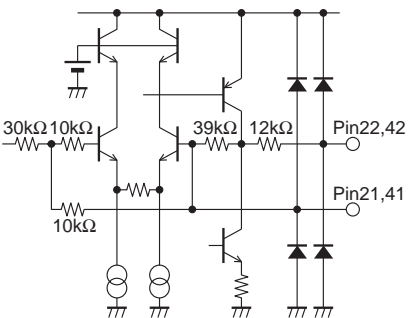
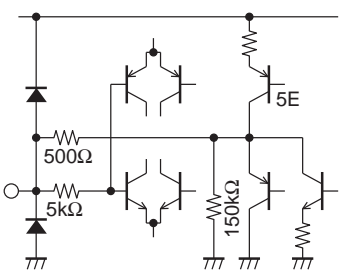
Pin No.	Pin Function Name	DC voltage		Function	Equivalent circuit
		AC level			
17	REC mute terminal	DC; Unsettled		Two levels control terminal. Hi ; 3.0V to Vcc Low ; 0V to 1.5V Hi: Pin 26 signal at REC is OFF(Mute).	
18	NR waiting DET terminal(L)	DC;		Terminal for waiting detector. The recommended external capacity is 10μF.	
45	NR waiting DET terminal(R)	AC;			
19	NR waiting filter terminal1(L)	DC; 2.5V		(Pin 19,Pin 44)between GND;4.7μF (Pin 20,Pin 43)between GND;0.01μF	
44	NR waiting filter terminal1(R)				
20	NR waiting filter terminal2(L)	AC;			
43	NR waiting filter terminal2(R)				
21	CCA reference terminal(L)	DC; 2.5V		By connecting 22μF between Pin 21, Pin 41 and GND, 4700pF between Pin 22, Pin 42 and GND, form the NR emphasis.	
22	NR emphasis terminal(L)	[ Pin21 Pin41 ]			
42	NR emphasis terminal(R)	AC;			
41	CCA reference terminal(R)				
23	HiFi/Nor selecting terminal (PB)  (2)Monitor control terminal at Pin 34 (EE)	DC ;Nor at 0.1V ;HiFi at TRACKING DC  AC:		In PB mode, Pin 23 becomes "TRACKING_DC" when inputting HiFi audio signal and becomes "L" when inputting Normal signal.  In EE mode, this is used as the terminal for monitor control of Pin 34.  Low(0 to 0.8V) ; VCO MIX Middle(1.4V to 3.6V) ; Lch VCO High(4.2V to VCC) ; Rch VCO	

Continued on next page.

# LA72670BM

Continued from preceding page.

Pin No.	Pin Function Name	DC voltage		Function	Equivalent circuit
		PB; 2.0V	AC level		
24	HEAD AMP input terminal (Hch)	DC		It becomes HEAD AMP input in PB mode. Hch is Pin24, and Lch is Pin 27. And, it becomes supply source of REC current in REC mode.	
27	HEAD AMP input terminal (Lch)	REC; 4.1V			
26	REC CURRENT AMP output terminal	DC; 4.1V		CURRENT AMP output in REC mode. Common input terminal in PB mode.	
		AC; 2.1Vp-p			
28	CURRENT AMP ADJUST terminal	DC; 2.4V		Terminal for adjusting the recording current.	
		AC:1.3Vp-p (L/R_MIX)			
29	SAP detection terminal	DC ;		Filter terminal in the SPA detector circuit.	
30	HiFi/NORMAL detection terminal	DC: Nor; 2.5V or more HiFi; 2.2V or less		This terminal is for detecting demodulation noise and output which has passed through the primary HPF (fc=140kHz).	

Continued on next page.

# LA72670BM

Continued from preceding page.

Pin No.	Pin Function Name	DC voltage	Function	Equivalent circuit
		AC level		
31	Monitor terminal	DC ; 2.5V	FM MIX output(Low), Lch VCO(middle), Rch VCO(High) can be monitored by controlling Pin 23 in REC mode. HOLD and DO pulses can be monitored by Pin 17 in PB mode. BPF of Lch and Rch can be monitored by serial control in PB mode (Pin 17 = 2.5V).	
		AC; 800mVp-p (L/R MIX)		
33	PB AMP output	DC; 2.5V	Output of HEAD AMP in PB mode.	
		AC; 100mVp-p to 600mVp-p		
34	PB FM input terminal	DC; OPEN	Input pin of FM in PB mode.	
		AC; 100mVp-p to 600mVp-p (L/R MIX)		
37	Serial data input terminal		Hi ; 3.5V to 5V Low ; 0V to 1.5V	
38	CLK input terminal		Hi ; 3.5V to 5V Low ; 0V to 1.5V	

Continued on next page.

# LA72670BM

Continued from preceding page.

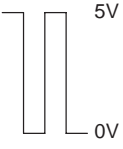
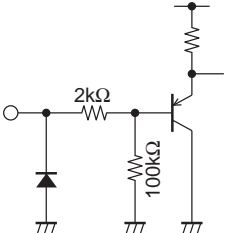
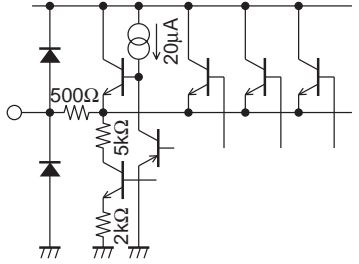
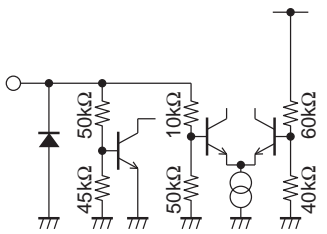
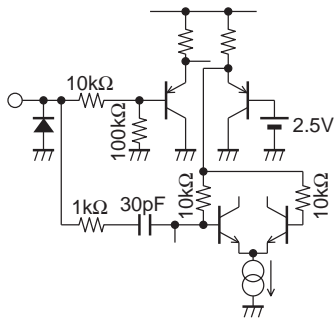
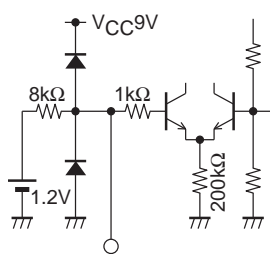
Pin No.	Pin Function Name	DC voltage	Function	Equivalent circuit
		AC level		
39	AF SW pulse input terminal	50Hz/60Hz 	Input terminal of AF SW pulse.  Hi ; 3.5V to 5V Low ; 0V to 1.5V	
40	MTS MODE OUT	DC;	Detection result output for M.T.S. signal.  STEREO+SAP : 3.8V STEREO : 3.0V MONO+SAP : 2.0V MONO : 1.0V	
49	MUTE control terminal	DC;	Mute control terminal.  Mute_ON : 3.0V to Vcc2 Mute_OFF : 0.0V to 1.0V	
51	FSC IN		Input terminal for FSC (3.58MHz). Recommended operating input level : 150 to 350mVp-p	
52	PCREGBGP	DC;	Power supply terminal of M.T.S. block. This power supply does not operate in PB mode.	

Continued on next page.

# LA72670BM

Continued from preceding page.

Pin No.	Pin Function Name	DC voltage	Function	Equivalent circuit
		AC level		
53	STEREO PLL FILTER	DC ; 3.8V	LPF terminal for STEREO PLL.	
55	PILOT CANCELLER FILTER	DC ; 3.8V	Control terminal of cancel signal for PILOT CANCELLER. DC voltage at this terminal is changed depending on amplitude of pilot signal, and controlled automatically to be small the pilot signal.	
56	FM FILTER		Filter terminal for making stable DC voltage of FM detection output in SIF part. Normally, use a condenser of 1μF. Increase the capacity value with concerning frequency characteristics of low. This terminal becomes composite signal input terminal of MTS by changing to 5V at Pin 57.	
57	SIF INPUT		Input terminal for SIF. The input impedance is about 1kΩ. Take care about pattern layout of the input circuit, because of causing buzz-beat and buzz by leaking noise signal into the input terminal. (The noise signal depending on sound is particularly video signal and chroma signal and so on. VIF carrier becomes noise signal.) Composite signal of MTS can be input by adding 5V to this terminal directly. (For test)	
58	REG FILT	DC ; 4.5V	Filter terminal of reference voltage source.	

Continued on next page.

# LA72670BM

Continued from preceding page.

Pin No.	Pin Function Name	DC voltage		Function	Equivalent circuit
		AC level			
59	FILTER AUTO ADJ	DC; 3.8V		Loop filter terminal of PLL for automatic adjusting.	
60	PILOT DET FILTER	DC; 3.8V		Detection terminal for PILOT detection circuit.	
61 76	PC_DC_MO PC_OUT_DBX	DC; 3.3V		Absorbing the DC offset of signal line by external capacity.	
62	PCDCOUT	DC; 3.8V		Absorbing the DC offset of signal line by external capacity.	
63	PCDCIN	DC; 3.8V		Absorbing the DC offset of signal line by external capacity.	

Continued on next page.

# LA72670BM

Continued from preceding page.

Pin No.	Pin Function Name	DC voltage	Function	Equivalent circuit
		AC level		
64	PCDBXIN	DC; 2.6V	Absorbing the DC offset of signal line by external capacity.	
65 67 72	MAIN V/I CONVERT SPE DET V/I CONVERT WID DEP V/I CONVERT	DC; 3.8V	Converting the voltage of signal into its current by external capacity.	
66 68	SPECTRAL DET WIDE BAND DET	DC;	Connecting terminal of smooth capacity of detection circuit for effective value.	
75	PCDCOSPE	DC;	Absorbing the DC offset of signal line by external capacity.	

Continued on next page.

# LA72670BM

Continued from preceding page.

Pin No.	Pin Function Name	DC voltage	Function	Equivalent circuit
		AC level		
78	Line Out(R) terminal	DC; 4.15V		
80	Line Out(L) terminal			

**Input selecting switch mode table ( Switch output signal )**

Sub address	0 1				0 2		HiFi(80Pin Lch Output	HiFi(78Pin) Rch Output	NORMAL OUT (6Pin)	Reference
	D8	D7	D3	D2	D8	D7				
1	0	0	0	0	0	0	TU L	TU R	TU L+TU R	
2	0	0	0	1	0	0	EXT1 L	EXT1 R	EXT1 L+EXT1 R	
3	0	0	1	0	0	0	EXT2 L	EXT2 R	EXT2 L+EXT2 R	
4	0	0	1	1	0	0	EXT3 L	EXT3 R	EXT3 L+EXT3 R	
5	0	0	0	0	0	1	TU L	TU R	TU L	
6	0	0	0	1	0	1	EXT1 L	EXT1 R	EXT1 L	
7	0	0	1	0	0	1	EXT2 L	EXT2 R	EXT2 L	
8	0	0	1	1	0	1	EXT3 L	EXT3 R	EXT3 L	
9	0	0	0	0	1	0	TU L	TU R	TU R	
10	0	0	0	1	1	0	EXT1 L	EXT1 R	TU R	
11	0	0	1	0	1	0	EXT2 L	EXT2 R	TU R	
12	0	0	1	1	1	0	EXT3 L	EXT3 R	TU R	
13	0	1	0	0	0	0	PB L	PB R	TU L+TU R	
14	0	1	0	1	0	0	PB L	PB R	EXT1 L+EXT1 R	
15	0	1	1	0	0	0	PB L	PB R	EXT2 L+EXT2 R	
16	0	1	1	1	0	1	PB L	PB R	EXT3 L	
17	0	1	0	0	0	1	PB L	PB R	TU L	
18	0	1	0	1	0	1	PB L	PB R	EXT1 L	
19	0	1	1	0	0	1	PB L	PB R	EXT2 L	
20	0	1	1	1	0	1	PB L	PB R	EXT3 L	
21	0	1	0	0	1	0	PB L	PB R	TU R	
22	0	1	0	1	1	0	PB L	PB R	-	
23	0	1	1	0	1	0	PB L	PB R	-	
24	0	1	1	1	1	0	PB L	PB R	-	
25	1	0	*	*	*	*	PB L	PB R	PB L+PB R	Audio-dubbing correspond

NOTE : \* is option.(1 or 0)



# LA72670BM

## (US) MULTIPLEX SERIAL MODE

SIGNAL	SERIAL SETTING SUB ADDRESS			TUNER OUT (HiFi input source : Tuner Mode)			MODE-OUT (Pin51)
	D8 ST/SAP	D7 L+R/SAP	D6 Forced MONO	Tuner Lch (Pin13)	Tuner Rch (Pin48)	MODE	
STEREO+SAP	1	0	0	SAP	SAP	SAP	TYP 3.8V
	0	*	0	L	R	STEREO	
	1	1	0	L+R	SAP	MULTI	
	*	*	1	L+R	L+R	MONO	
STEREO	*	*	0	L	R	STEREO	TYP 3.0V
	*	*	1	L+R	L+R	MONO	
MONO+SAP	1	0	0	SAP	SAP	SAP	TYP 2.0V
	1	1	0	L+R	SAP	MULTI	
	0	*	0	L+R	L+R	MONO	
	*	*	1	L+R	L+R	MONO	
MONO	*	*	*	L+R	L+R	MONO	TYP 1.0V

### Output selecting switch mode table

Sub address	0 3	0 2					Line out Lch	Line out Rch	RF MOD OUT	Through Monitor	Through Monitor RF MOD SW
	D3	D6	D4	D3	D2	D1					
1	*	0	0	0	0	0	HiFi L	HiFi R	HiFi L+HiFi R	OFF	OFF
2	*	0	0	0	0	1	HiFi L	HiFi L	HiFi L	OFF	OFF
3	*	0	0	0	1	0	HiFi R	HiFi R	HiFi R	OFF	OFF
4	*	0	0	1	0	0	MIX L	MIX R	MIXL+MIXR	OFF	OFF
5	*	0	0	1	0	1	MIX L	MIX L	MIX L	OFF	OFF
6	*	0	0	1	1	0	MIX R	MIX R	MIX R	OFF	OFF
7	*	0	1	0	0	0	NORMAL	NORMAL	NORMAL	OFF	OFF
8	*	0	1	0	0	1	NORMAL	NORMAL	NORMAL	OFF	OFF
9	*	0	1	0	1	0	NORMAL	NORMAL	NORMAL	OFF	OFF
10	0	1	*	*	0	0	BS L	BS R	BS L+BS R	BS	ON
11	0	1	*	*	0	1	BS L	BS L	BS L	BS	ON
12	0	1	*	*	1	0	BS R	BS R	BS R	BS	ON
13	1	1	0	0	0	0	BS L	BS R	HiFi L+HiFi R	BS	OFF
14	1	1	0	0	0	1	BS L	BS R	HiFi L	BS	OFF
15	1	1	0	0	1	0	BS L	BS R	HiFi R	BS	OFF

1. \* is option.(1 or 0)

2. MIX L=HiFi L+NORMAL, MIX R=HiFi R+NORMAL

### Through\_Monitor SW Table

	G2D6	G3D3	G1D1	G2D4D3	LINE(L)	LINE(R)	RFC_OUT
EE_MODE	1	0	-	00	Monitor(L)	Monitor(R)	Monitor_MIX
	1	1	-	00	Monitor(L)	Monitor(R)	INSEL_MIX
	0	1	-	00	INSEL(L)	INSEL(R)	INSEL_MIX
	0	0	-	00	INSEL(L)	INSEL(R)	INSEL_MIX
PB_MODE	1	0	-	00	Monitor(L)	Monitor(R)	Monitor_MIX
	1	1	-	00	Monitor(L)	Monitor(R)	PB_MIX
	0	1	-	00	PB(L)	PB(R)	PB_MIX
Nor_Tape	0	0	-	00	PB(L)	PB(R)	PB_MIX
	1	0	0	00	Nor	Nor	Nor
	1	1	0	00	Monitor(L)	Monitor(R)	Nor
	0	1	0	00	Nor	Nor	Nor
Nor_Tape	0	0	0	00	Nor	Nor	Nor
	1	0	1	00	Monitor(L)	Monitor(R)	Monitor_MIX
	1	0	1	00	Monitor(L)	Monitor(R)	Monitor_MIX

Note: When output Monitor to RFC\_OUT at Nor\_Tape replayed (G2D6:1,G3D3:0), Set G1D1(HiFi auto Distinction) to 1 and select G2D4D3:00 (HiFi).

# LA72670BM

## Serial data specification ( I<sup>2</sup>C BUS communication )

Address	Data byte ( Underline is initial setting. )							
	MSB D8	D7	D6	D5	D4	D3	D2	LSB D1
( 0 1 ) 00000001	EE/PB/ Audio-dubbing  <u>00:EE</u> 01:PB 10:Audio-dubbing		LINE OUT MUTE  0:OFF <u>1:ON</u>	Fixed 0	REC/EE  <u>0:EE</u> 1:REC	Input source selection  <u>00:TUNER</u> 01:EXT1 10:EXT2 11:EXT3		Auto HiFi DET  <u>0:ON</u> 1:OFF
( 0 2 ) 00000010	Normal Input mode selection  <u>00:L/R MIX</u> 01:Lch 10:TU(R)		Trough Monitor BS  <u>0:OFF</u> 1:ON	Fixed 0	Output mode selection  <u>00:HiFi</u> 01:MIX (HiFi+NOR) 10:NORMAL		Output channel selection  <u>00:STEREO</u> 01:L-ch 10:R-ch	
( 0 3 ) 00000011	VCO carrier (MHz)  <u>00:1.3/1.7</u> 01:1.4/1.8	REC FM MIX  00:9dB <u>01:8dB</u> 10:10dB 11:11dB		DO ON/OFF  <u>0:ON</u> 1:OFF	LINE OUT Signal level  <u>0:-9dBv</u> 1:-8dBv	Through monitor RFC SW  <u>0:ON</u> 1:OFF	HiFi DET selection  <u>0:TYP</u> 1:+10%	HiFi DET selection  <u>0:TYP</u> 1:-10%
( 0 4 ) 00000100	SAP_Gain <u>0:0dB</u> 1:2dB	NORMAL INPUT Gain  <u>0:0dB</u> 1:3dB	REC current Level selection  00:0dB 01:-1.5dB 10:-55dB		NORMAL OUT MUTE  <u>0:OFF</u> 1:ON	fsc (MHz)  <u>0:3.58</u> 1:4.43	RF MOD ALC level  <u>0:-5dBv</u> 1:-1dBv	Fixed 0
( 0 5 ) 00000101	ST/SAP  <u>0:ST</u> 1:SAP	SAP/(L+R)  <u>0:SAP</u> 1:L+R	Forced MONO  <u>0:OFF</u> 1:ON	MTS MUTE  <u>0:OFF</u> 1:ON	EP/SP  <u>0:SP</u> 1:EP	Fixed 0	Fixed 0	Fixed 0*1
00000110	Use in investigating the shipment							
00000111	Use in investigating the shipment							

Note 1: When FSTVCO is measured, D1 in address 00000101 is set to 1.

Note 2: Address 00000110 and 00000111 are used in investigating the shipment, please send "0" data to all bits at refreshing. the data.)

**I<sup>2</sup>C BUS serial interface specification**

(1) DATA TRANSFER MANUAL

This IC adopts control method(IIC-BUS) with serial data, and controlled by two terminals which called SCL(serial clock) and SDA (serial data).At first, set up the condition of starting data transfer<sup>\*1</sup>, and after that, input 8 bit data to SDA terminal with synchronized SCL terminal clock. The order of transferring is first, MSB (the Most Scale of Bit),and save the order. The 9th bit takes ACK (ACKnowledge) period, during SCL terminal takes "H", this IC pull down the SDA terminal. After transferred the necessary data, two terminals lead to set up and of data transfer stop condition<sup>\*2</sup>, thus the transfer comes to close.

As a part of transfer data write down to internal memory (V latch system), internal control doesn't change just after the transfer.

\*1 Defined by SCL rise down SDA during 'H' period.

\*2 Defined by SCL rise up SDA during 'H' period.

(2) TRANSFER DATA FORMAT

After transfer start condition, transfers slave address(1110100\*) to SDA terminal, next, sub address(0000\*\*\*\*), control data<sup>\*3</sup>, then, stop condition(See figure 1). And this LSI have a auto address increment function, then, next of slave address transfer, transfer sub address(n)<sup>\*4</sup>, group (n) data, after that, group (n+1) and so on.

Data works with all of the bit, transfer the stop condition before stop 8bit transfer, and to stop transfer, it will be canceled only the data of group.

\*3 There are 1 to 5 groups.

\*4 Pointed date by sub address becomes group No. of next control data.

Fig.1 DATA STRUCTURE "WRITE" mode

START Condition	Slave Address	R/W ACK	Sub Address(n) ACK	Control data(n) ACK	control data(n+1) ACK	.....	STOP condition
-----------------	---------------	------------	-----------------------	------------------------	--------------------------	-------	----------------

\*5 It is called R/W bit.

data-1 means data for group-1, data-2 means data for group-2.

(3) INITIALIZE

This LSI is initialized for circuit protection.

The initialization period is decided Pin 16 capacity value by internal impedance 15kΩ, and shown with

$t = -CR \times \ln(0.2)$ . Data cannot be accepted for this period.

$t = 530\text{ms}$  at  $C = 22\mu\text{F}$ , In this case, Please transmit data in consideration of the uneven after about 700ms.

# LA72670BM

## (4) SERIAL INPUT SIGNAL FORMAT

Parameter	Symbol	min	max	unit
LOW level input voltage	VIL	-0.5	1.5	V
HIGH level input voltage	VIH	3.0	5.5	V
LOW level output current	IOL	-	3.0	mA
SCL clock frequency	fSCL	0	100	kHz
Set-up time for a repeated START condition	tSU:STA	4.7		μs
Hold time START condition. After this period, the first clock pulse is generated	tHD:STA	4.0		μs
LOW period of the SCL clock	tLOW	4.7		μs
Rise time of both SDA and SDL signals	tR	0	1.0	μs
HIGH period of the SCL clock	tHIGH	4.0	-	μs
Fall time of both SDA and SDL signals	tF	0	1.0	μs
Data hold time:	tHD:DAT	0	-	μs
Data set-up time	tSU:DAT	250	-	ns
Set-up time for STOP condition	tSU:STO	4.0	-	μs
BUS free time between a STOP and START condition	tBUF	4.7	-	μs

## (5) Definition of timing

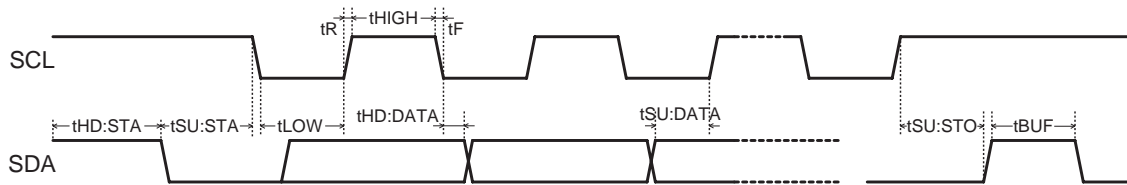

- SANYO Semiconductor Co.,Ltd. assumes no responsibility for equipment failures that result from using products at values that exceed, even momentarily, rated values (such as maximum ratings, operating condition ranges, or other parameters) listed in products specifications of any and all SANYO Semiconductor Co.,Ltd. products described or contained herein.
- SANYO Semiconductor Co.,Ltd. strives to supply high-quality high-reliability products, however, any and all semiconductor products fail or malfunction with some probability. It is possible that these probabilistic failures or malfunction could give rise to accidents or events that could endanger human lives, trouble that could give rise to smoke or fire, or accidents that could cause damage to other property. When designing equipment, adopt safety measures so that these kinds of accidents or events cannot occur. Such measures include but are not limited to protective circuits and error prevention circuits for safe design, redundant design, and structural design.
- In the event that any or all SANYO Semiconductor Co.,Ltd. products described or contained herein are controlled under any of applicable local export control laws and regulations, such products may require the export license from the authorities concerned in accordance with the above law.
- No part of this publication may be reproduced or transmitted in any form or by any means, electronic or mechanical, including photocopying and recording, or any information storage or retrieval system, or otherwise, without the prior written consent of SANYO Semiconductor Co.,Ltd.
- Any and all information described or contained herein are subject to change without notice due to product/technology improvement, etc. When designing equipment, refer to the "Delivery Specification" for the SANYO Semiconductor Co.,Ltd. product that you intend to use.
- Information (including circuit diagrams and circuit parameters) herein is for example only; it is not guaranteed for volume production.
- Upon using the technical information or products described herein, neither warranty nor license shall be granted with regard to intellectual property rights or any other rights of SANYO Semiconductor Co.,Ltd. or any third party. SANYO Semiconductor Co.,Ltd. shall not be liable for any claim or suits with regard to a third party's intellectual property rights which has resulted from the use of the technical information and products mentioned above.

This catalog provides information as of April, 2007. Specifications and information herein are subject to change without notice.