



SANYO Semiconductors

DATA SHEET

LA72700V — Monolithic Linear IC US MTS (Multi Channel Television Sound) Decoder

Overview

LA72700V is a US MTS (Multi Channel Television Sound) decoder.

Features

- With SIF circuit, STEREO channel separation is alignment-free.
- Built-in filters are adjustment free.
- SAP output level is selectable 2 levels.
- Included control function for STEREO and SAP detection sensitivity.

Functions

- SIF FM-Demodulator.
- STEREO decoder.
- ALC function is included.
- dbx Noise Reduction system.
- SAP demodulator.
- STEREO detection.
- SAP detection.

Specifications

Maximum Ratings at $T_a = 25^\circ\text{C}$

Parameter	Symbol	Conditions	Ratings	Unit
Maximum power supply voltage	$V_{CC \text{ max}}$		9.6	V
Allowable power dissipation	$P_d \text{ max}$	$T_a \leq 70^\circ\text{C}^*$	810	mW
Operating temperature	T_{opr}		-10 to +70	$^\circ\text{C}$
Storage temperature	T_{stg}		-55 to +150	$^\circ\text{C}$

* ON board (114.3 × 76.1 × 1.6 mm Glass Epoxy resin board)

- Any and all SANYO Semiconductor products described or contained herein do not have specifications that can handle applications that require extremely high levels of reliability, such as life-support systems, aircraft's control systems, or other applications whose failure can be reasonably expected to result in serious physical and/or material damage. Consult with your SANYO Semiconductor representative nearest you before using any SANYO Semiconductor products described or contained herein in such applications.
- SANYO Semiconductor assumes no responsibility for equipment failures that result from using products at values that exceed, even momentarily, rated values (such as maximum ratings, operating condition ranges, or other parameters) listed in products specifications of any and all SANYO Semiconductor products described or contained herein.

SANYO Semiconductor Co., Ltd.

TOKYO OFFICE Tokyo Bldg., 1-10, 1 Chome, Ueno, Taito-ku, TOKYO, 110-8534 JAPAN

N2206 / O2505 MS OT B8-8873 No.A0015-1/16

LA72700V

Operating Conditions at $T_a = 25^\circ\text{C}$

Parameter	Symbol	Conditions	Ratings	Unit
Recommended operating voltage	V_{CC}		9.0	V
Operating voltage range	$V_{CC\ op}$		8.5 to 9.5	V

Electrical Characteristics at $T_a = 25^\circ\text{C}$, $V_{CC} = 9.0\text{V}$

Parameter	Symbol	Conditions	Ratings			Unit
			min	typ	max	
Current dissipation	I_{CC}	No signal Inflow current at pin 31 * Default condition	50	60	70	mA
SIF input level (Reference)	VILIM	$f_c = 4.5\text{MHz}$ Deviation MONO (300Hz, Mod = 100%, Pre-emphasis ON) → ±25kHz	(80)	(90)	(100)	$\text{dB}\mu\text{V}$
Base band input level (Reference)	VILIMB	100% Modulation MONO(L+R): 530mVp-p (300Hz, Pre-emphasis ON) SUB(L-R): 380mVp-p (300Hz, dbx-NR ON), Pilot: 110mVp-p SAP: 300mVp-p (300Hz, dbx-NR ON)				
MONO output level	VOMON	Input: $f_m = 1\text{kHz}$, 100% Mod, MONORAL Measure OUT (L), OUT (R)	-7.0	-6.0	-5.0	dBV
MONO distortion	THDMON	Input: $f_m = 1\text{kHz}$, 100% Mod, MONORAL Measure OUT (L), OUT (R)		0.15	0.6	%
MONO frequency characteristics	FCM1	Input: $f_m = 8\text{kHz}$, 30% Mod, MONORAL Measure OUT(L), OUT(R), Ratio from $f_m = 1\text{kHz}$ level.	-2	0	2	dB
MONO S/N ratio	SNM	S = VOMON, N = 0% Mod Measure OUT (L), OUT (R) With 15kHz LPF, JIS-A	55	65		dB
STEREO output level	VOST	Input: $f_m = 1\text{kHz}$, 100% Mod, STEREO Measure OUT (L), OUT(R)	-7.0	-6.0	-5.0	dBV
STEREO distortion	THDS	Input: $f_m = 1\text{kHz}$, 100% Mod, STEREO Measure OUT (L), OUT (R)		1.0	2.5	%
STEREO frequency characteristics	FCS1	$f_m = 8\text{kHz}$, 30% Mod, STEREO Measure OUT (L), OUT (R), Ratio from $f_m = 1\text{kHz}$ level.	-3	0	3	dB
STEREO S/N ratio	SNS	S = VOST, N = 0% Mod Measure OUT (L), OUT (R) With 15kHz LPF, JIS-A	50	60		dB
STEREO separation 1	STSE1	$f = 300\text{Hz}$ (R/L), 30% Mod Measure ratio OUT (L) with OUT (R)	20	25		dB
STEREO separation 2	STSE2	$f = 3\text{kHz}$ (R/L), 30% Mod Measure ratio OUT (L) with OUT (R)	20	25		dB
STEREO Detection level-1	VINSD1	Except Stereo Detection → Stereo Detection Measure PILOT level, at STERO det.	52	57	62	%
STEREO Detection level-2	VINSD2	Except Stereo Detection → Stereo Detection * Insert Resistor pin 14 to GND (ex. $51\text{k}\Omega$) Measure PILOT level, at STERO det.	62	67	72	%

Continued on next page.

LA72700V

Continued from preceding page.

Parameter	Symbol	Conditions	Ratings			Unit
			min	typ	max	
STEREO detection hysteresis	HYST	Input Mod. Difference at Stereo /Except Stereo Det. * at default condition	10	15	25	%
SAP output level-1	VOSA	Fm = 1kHz, 100% Mod, SAP Measure OUT (L), OUT * at bit6 = 0	-7.5	-6.5	-5.5	dBV
SAP output level-2	VOSA2	Fm = 1kHz, 100% Mod, SAP Measure OUT (L), OUT * at bit6 = 1	-5.5	-4.5	-3.5	dBV
SAP distortion	THDSA	Fm = 1kHz, 100% Mod, SAP Measure OUT (L), OUT		1.5	3.5	%
SAP S/N ratio	SNSA	S = VOSA, N = 0% Mod, Measure OUT (L), OUT (R) With 15kHz LPF, JIS-A	55	65		dB
SAP detection level-1	VINSA1	Measure SAP carrier level, when SAP det * Default condition	13	18	23	%
SAP detection level-2 (Reference)	VINSA2	Measure SAP carrier level, when SAP det * pin15 to GND (ex 33kΩ)	(5)	(10)	(15)	%
SAP detection level-3 (Reference)	VINSA3	Measure SAP carrier level, when SAP det * pin15 to GND (ex 8.2kΩ)	(20)	(25)	(30)	%
SAP detection hysteresis	HYSA	Input Mod. Difference at SAP/Except SAP Det. * at default condition	2	5	10	%
MODE output MONO	MODMO	Input = MONO: f = 1kHz, 0% Mod Measure pin32	0.7	1	1.3	V
MODE output SAP	MODSA	Input = SAP: Carrier Measure pin32	1.7	2	2.3	V
MODE output STEREO	MODST	Input = STEREO: Pilot Measure pin32	2.7	3	3.3	V
MODE output ST + SAP	MODSS	Input = STEREO: Pilot, SAP: Carrier Measure pin32	3.5	3.8	4.2	V
Distortion	THDALC	MONO 1kHz Mod 100% * ALC on Measure OUT (L), OUT (R)		0.3	0.5	%

* Normally measurement condition is Input = SIF mode (-90dBμV), ALC = OFF

* " Reference " Items are reference levels, their specs are no-guarantee.

Package Dimensions

unit : mm

3247B

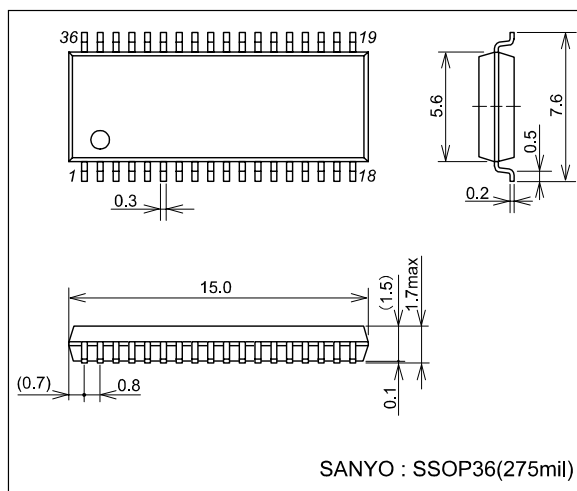

Block Diagram and Application Circuit Example

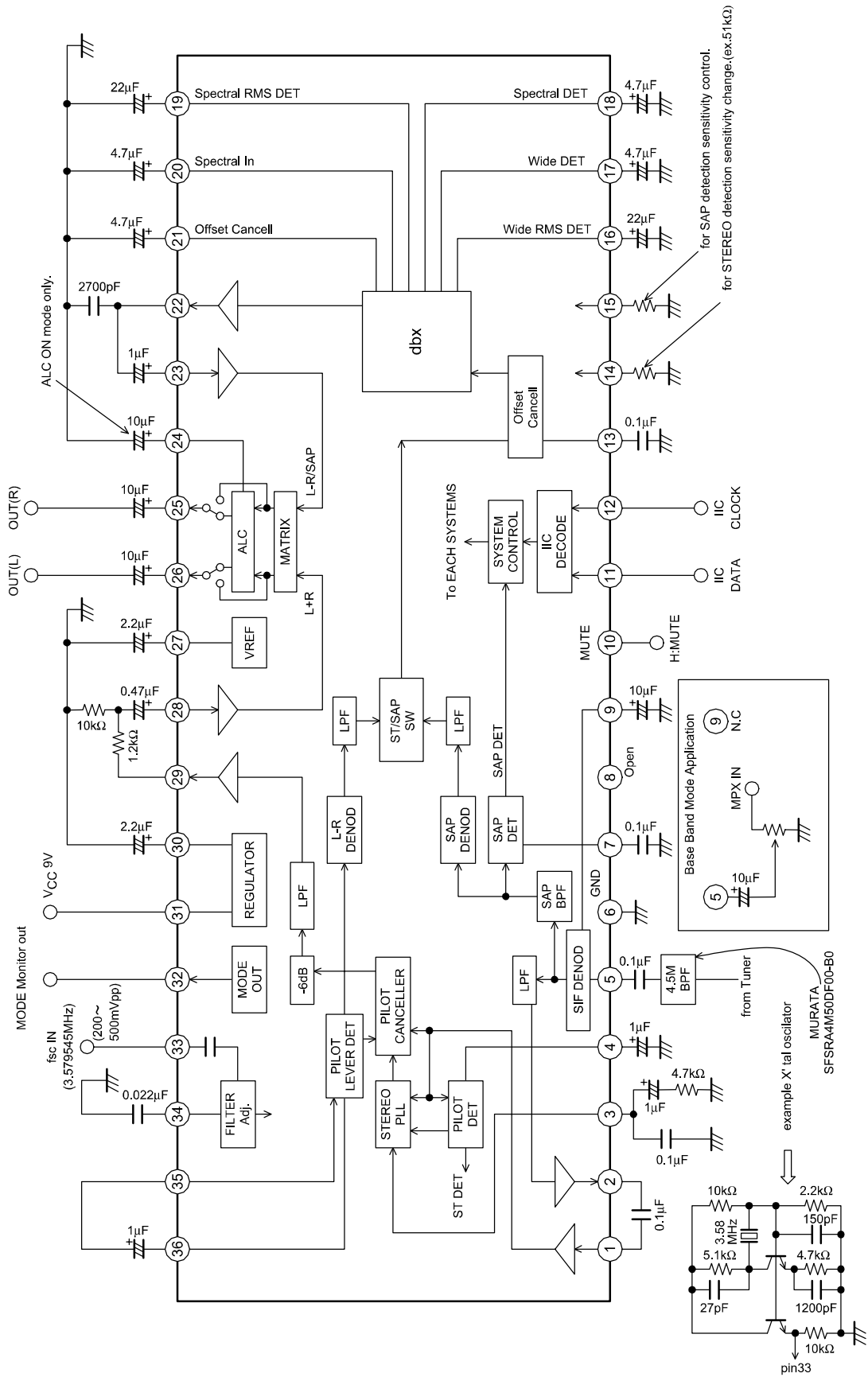

00p-1 (Normally use : group-1 only)

D8	D7	D6	D5	D4	D3	D2	D1	Condition
*						0	0	Stereo
						0	1	SAP
						1	0	Both
						1	1	Prohibit
*					0			Normal (Auto det)
					1			Forced Mono
*				0				Normal (MUTE off)
				1				MUTE
*			0					ALC off (Through)
			1					ALC on
*		0						SAP LEVEL-1
		1						SAP LEVEL-2
*	0							SIF mode
	1							Base Band mode
*	0							Fix
	1							Prohibit (TEST MODE)

*: Initial condition

Read out data

D8	D7	D6	D5	D4	D3	D2	D1	Condition
		0	0	0	0	0	0	Fixed
	0							Normal
	1							SAP det
0								Normal
1								Stereo det

Test mode condition

When STOP condition transform at Grp-1 data-end, controlled NORMAL mode.

Grp-2(Only test condition: Normally, this data is no-need)

D8	D7	D6	D5	D4	D3	D2	D1	Condition/Monitor position
0	0	0	0	0	0	0	0	Normal (Usually, Fixed)
0	0	0	0	0	0	0	1	TEST-1 SIF output
0	0	0	0	0	0	1	0	TEST-2 SAP BPF
0	0	0	0	0	0	1	1	TEST-3 SAP VCO
0	0	0	0	0	1	0	0	TEST-4 ST VCO
0	0	0	0	0	1	0	1	TEST-5 ADJ VCO
0	0	0	0	0	1	1	0	TEST-6 dbx input
0	0	0	0	0	1	1	1	TEST-7 L-R Demod output
0	0	0	0	1	0	0	0	TEST-8 Pilot cancel
0	0	0	0	1	0	0	1	TEST-9 dbx 2.19k LPF
0	0	0	0	1	0	1	0	TEST-10 dbx 408 LPF
0	0	0	0	1	0	1	1	TEST-11 dbx DET 10k LPF
0	0	0	0	1	1	0	0	TEST-12 dbx SPEC 7.6k LPF
0	0	0	0	1	1	0	1	TEST-13 dbx SPEC output
0	0	0	0	1	1	1	0	TEST-14 (No operation)
0	0	0	0	1	1	1	1	TEST-15 (No operation)

Pin Functions

No.	Pin function	DC voltage	Input/output form	Reference
		AC level		
1	PC_DC_IN	DC: 3.8V AC: 2.4Vp-p	<p style="text-align: center;">OMP05005</p>	AC coupling (Input)
2	PC_DCOUT	DC: 3.8V AC: 2.4Vp-p		AC coupling (Output)
3	PCSTFLT	DC: 3.8V	<p style="text-align: center;">OMP05006</p>	Stereo VCO PLL filter
4	PCPLDET	DC: 3.8V	<p style="text-align: center;">OMP05007</p>	Pilot level detect
5	PISIF	DC: 3.7V	<p style="text-align: center;">OMP05008</p>	Signal input

Continued on next page.

LA72700V

Continued from preceding page.

No.	Pin function	DC voltage	Input/output form	Reference
		AC level		
6	GND			
	CSAPDET	DC: 2.8V	<p style="text-align: center;">OMP05009</p>	SAP carrier level detect
8	NC			No connect
9	PC FIL	DC: 2.9V	<p style="text-align: center;">OMP05010</p>	SIF offset cancel
10	MUTE	DC: 0V	<p style="text-align: center;">OMP05011</p>	MUTE = 5V
11	SDA		<p style="text-align: center;">OMP05012</p>	Serial data input
12	SCL		<p style="text-align: center;">OMP05013</p>	Serial clock input

Continued on next page.

LA72700V

Continued from preceding page.

No.	Pin function	DC voltage		Input/output form	Reference
		AC level			
13	PC DBXIN	DC: 2.5V		<p style="text-align: center;">OMP05014</p>	Offset cancel filter
14	PSTSENS	DC: 3.1V		<p style="text-align: center;">OMP05015</p>	Stereo det sensitivity change OPEN = default Insert resistor(30k or over) = Low sensitivity
15	PSAPSENS	DC: 3.1V		<p style="text-align: center;">OMP05016</p>	SAP detect sensitivity control OPEN = default controlled by insert resistor * see electrical reference
16	PCTNWID	DC: 4.0V		<p style="text-align: center;">OMP05017</p>	dbx RMS detect(wide band)
17	PCDETWID	DC: 3.8V		<p style="text-align: center;">OMP05018</p>	dbx wide detect

Continued on next page.

LA72700V

Continued from preceding page.

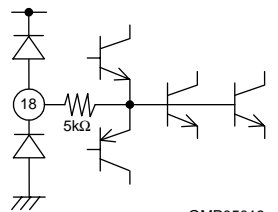
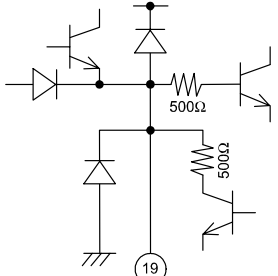
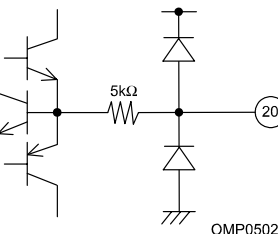
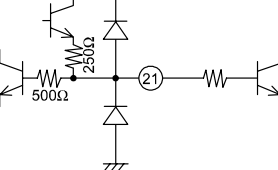
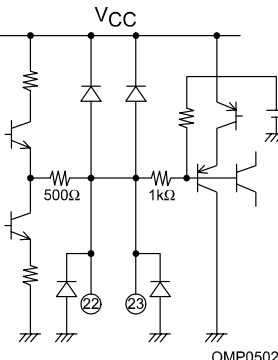
No.	Pin function	DC voltage		Input/output form	Reference
		DC level	AC level		
18	PCTIMSPE	DC: 3.8V		 <p style="text-align: center;">OMP05019</p>	dbx spectral detect
19	PCDETSPE	DC: 3.8V		 <p style="text-align: center;">OMP05020</p>	dbx RMS detect (Spectral band)
20	PCSPECIN	DC: 3.8V		 <p style="text-align: center;">OMP05021</p>	dbx main signal V/I convert filter
21	PCDOSPE	DC: 3.8V AC: 220mVp-p		 <p style="text-align: center;">OMP05022</p>	Offset cancel filter
22	PCDBXOUT	DC: 3.8V AC: 220mVp-p		 <p style="text-align: center;">OMP05023</p>	AC coupling (Output)
23	PCDBX_IN				AC coupling (Input)

Continued on next page.

LA72700V

Continued from preceding page.

No.	Pin function	DC voltage		Input/output form	Reference
		AC level			
24	PCALCFIL	DC: 0.6V		<p style="text-align: right;">OMP05024</p>	ALC filter * When ALC function no-use, this terminal is open.
25	PORCH	DC: 3.8V AC: 1.4mVp-p		<p style="text-align: right;">OMP05025</p>	Line out R
26	POLCH	DC: 3.8V AC: 1.4mVp-p		<p style="text-align: right;">OMP05026</p>	Line out L
27	PCREG	DC: 3.8V		<p style="text-align: right;">OMP05027</p>	Reference Voltage

Continued on next page.

LA72700V

Continued from preceding page.

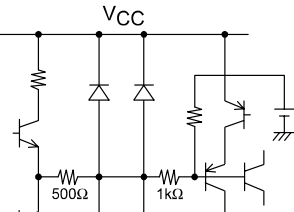
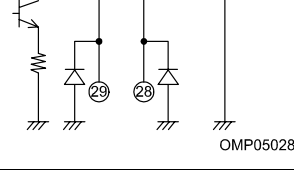
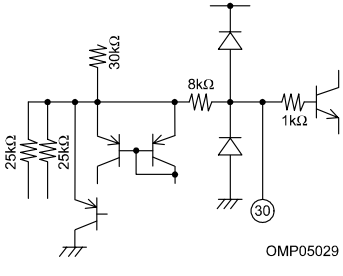
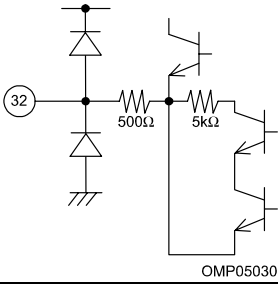
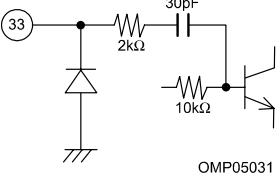
No.	Pin function	DC voltage		Input/output form	Reference
		DC	AC level		
28	PMAIN_IN	DC: 3.5V	AC: 220mVp-p		AC coupling (Input)
29	PMAINOUT	DC: 3.8V	AC: 220mVp-p		AC coupling (Output)
30	PCREG76	DC: 1.2V			Regulator
31	VCC				
32	POLED	DC*	* See Mode table		Mode out MONO = 0.9V SAP = 2.0V STEREO = 3.0V STEREO+SAP = 3.8V
33	PICKFSC	DC: 0V	AC* * 200mVp-p Recommend		Fsc input 3.579545MHz, 200mVp-p

Continued on next page.

LA72700V

Continued from preceding page.

No.	Pin function	DC voltage		Input/output form	Reference
		AC level			
34	PCDJFIL	DC: 2.5V			Filter adjustment signal detect
35	PCPLC	DC: 6.3V			Pilot canceller reference-1
36	PCPLC2	DC: 6.3V			Pilot canceller reference-2

Serial Control (I²C)

(1) Data Transfer Manual

This LSI adopts control method (I²C -BUS) with serial data, and controlled by two terminals which called SCL (serial clock) and SDA (serial data). At first, set up ^{*1}the condition of starting data transfer, and after that, input 8 bit data to SDA terminal with synchronized SCL terminal clock. The order of transferring is first, MSB (the Most Scale of Bit), and save the order. The 9th bit takes ACK (Acknowledge) period, during SCL terminal takes 'H', this LSI pull down the SDA terminal. After transferred the necessary data, two terminals lead to set up and of ^{*2}data transfer stop condition, thus the transfer comes to close.

*1 Defined by SCL rise down SDA during 'H' period.

*2 Defined by SCL rise up SDA during 'H' period.

(2) Transfer Data Format

After transfer start condition, transfers slave address (1000000*) to SDA terminal, control data, then, stop condition (See figure 1).

Slave address is made up of 7bits, ^{*3}8th bit shows the direction of transferring data, if it is "L", takes write mode (As this LSI side, this is input operation mode), and in case of 'H', reading mode (As this LSI side, this is output operation mode).

Data works with all of bit, transfer the stop condition before stop 8bit transfer, and to stop transfer, it will be canceled the transfer dates.

*3 It is called R/W bit.

Fig.1 DATA STRUCTURE " WRITE " mode

START Condition	Slave Address	R/W L	ACK	Control data	ACK	STOP condition
-----------------	---------------	----------	-----	--------------	-----	----------------

Fig.2 DATA STRUCTURE " READ " mode

START condition	Slave Address	R/W H	ACK	Internal Data*	ACK	STOP condition
-----------------	---------------	----------	-----	----------------	-----	----------------

* Output 5bits data as follows;

bit8 is result of STERO DET (H: STEREO)

bit7 is result of SAP DET (H: SAP)

bit6 to bit1 are fixed to "L"

(3) Initialize

This LSI is initialized for circuit protection. Initial condition is "0 (all bits)".

Parameter	Symbol	Min	Max	Unit
LOW level input voltage	V_{IL}	-0.5	1.5	V
HIGH level input voltage	V_{IH}	3.0	5.5	V
LOW level output current	I_{OL}		3.0	mA
SCL clock frequency	f_{SCL}	0	100	kHz
Set-up time for a repeated START condition	$t_{SU: STA}$	4.7		μs
Hold time START condition. After this period, the first clock pulse is generated	$t_{HD: STA}$	4.0		μs
LOW period of the SCL clock	t_{LOW}	4.7		μs
Rise time of both SDA and SDL signals	t_R	0	1.0	μs
HIGH period of the SCL clock	t_{HIGH}	4.0		μs
Fall time of both SDA and SDL signals	t_F	0	1.0	μs
Data hold time	$t_{HD: DAT}$	0		μs
Data set-up time	$t_{SU: DAT}$	250		ns
Set-up time for STOP condition	$t_{SU: STO}$	4.0		μs
BUS free time between a STOP and START condition	t_{BUF}	4.7		μs

Timing Chart

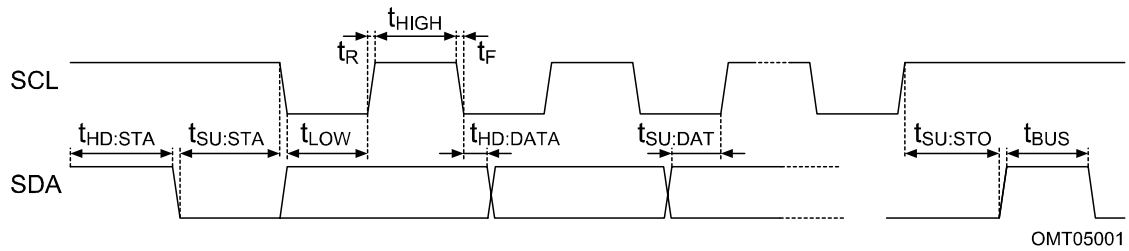

Measurement Circuit

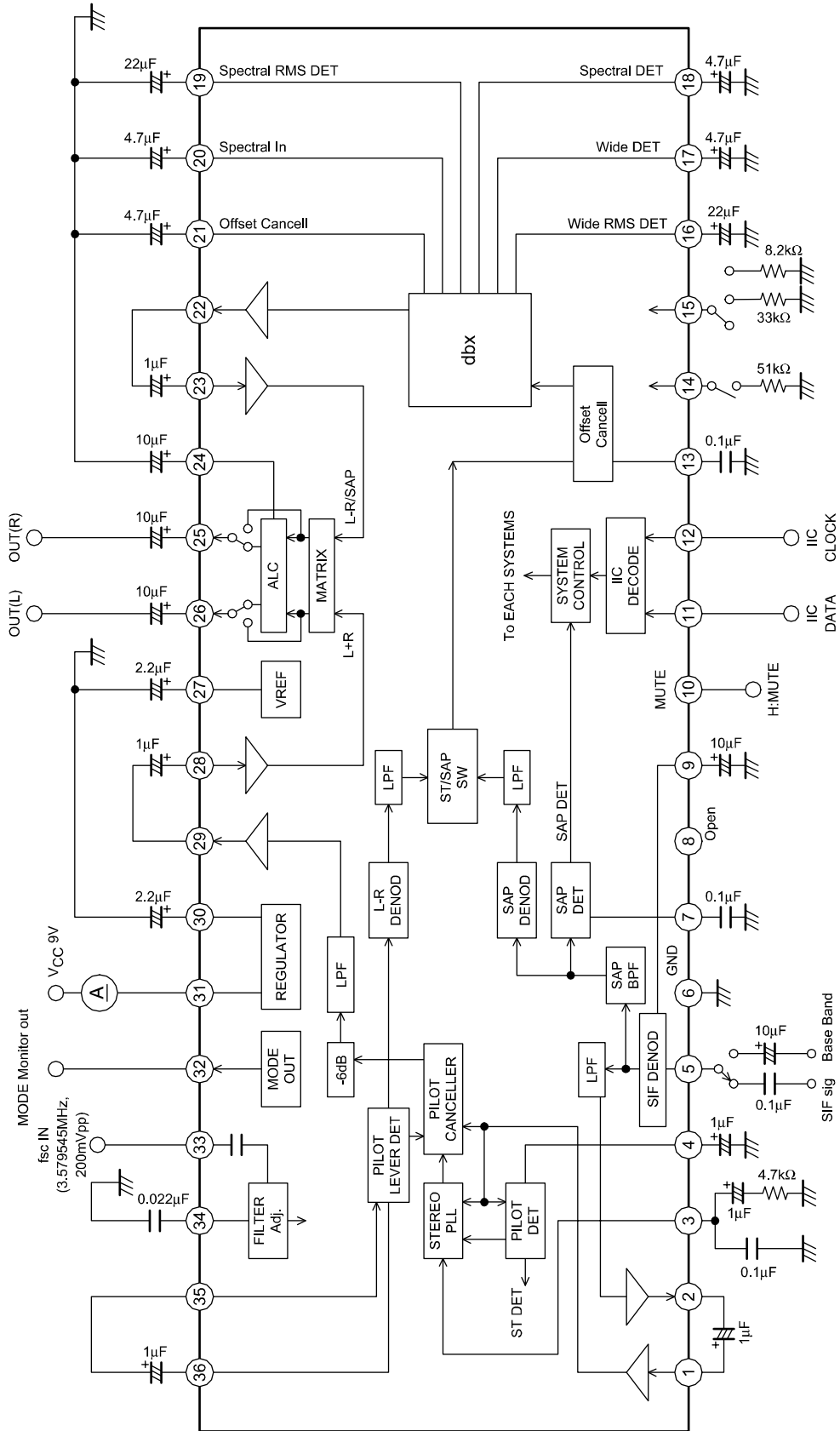

OMB05037

- Specifications of any and all SANYO Semiconductor products described or contained herein stipulate the performance, characteristics, and functions of the described products in the independent state, and are not guarantees of the performance, characteristics, and functions of the described products as mounted in the customer's products or equipment. To verify symptoms and states that cannot be evaluated in an independent device, the customer should always evaluate and test devices mounted in the customer's products or equipment.
- SANYO Semiconductor Co., Ltd. strives to supply high-quality high-reliability products. However, any and all semiconductor products fail with some probability. It is possible that these probabilistic failures could give rise to accidents or events that could endanger human lives, that could give rise to smoke or fire, or that could cause damage to other property. When designing equipment, adopt safety measures so that these kinds of accidents or events cannot occur. Such measures include but are not limited to protective circuits and error prevention circuits for safe design, redundant design, and structural design.
- In the event that any or all SANYO Semiconductor products (including technical data, services) described or contained herein are controlled under any of applicable local export control laws and regulations, such products must not be exported without obtaining the export license from the authorities concerned in accordance with the above law.
- No part of this publication may be reproduced or transmitted in any form or by any means, electronic or mechanical, including photocopying and recording, or any information storage or retrieval system, or otherwise, without the prior written permission of SANYO Semiconductor Co., Ltd.
- Any and all information described or contained herein are subject to change without notice due to product/technology improvement, etc. When designing equipment, refer to the "Delivery Specification" for the SANYO Semiconductor product that you intend to use.
- Information (including circuit diagrams and circuit parameters) herein is for example only; it is not guaranteed for volume production. SANYO Semiconductor believes information herein is accurate and reliable, but no guarantees are made or implied regarding its use or any infringements of intellectual property rights or other rights of third parties.

This catalog provides information as of October, 2005. Specifications and information herein are subject to change without notice.