

Version : 1.7

<p>TECHNICAL SPECIFICATION</p> <p>MODEL NO : PD104VT2</p>

Customer's Confirmation

Customer _____

By _____

PVI's Confirmation

Confirmed By _____

Prepared By _____

PRIME VIEW INTERNATIONAL CO.,LTD.
3,LI SHIN RD. 1,SCIENCE-BASED INDUSTRIAL
PARK,HSINCHU,TAIWAN,R.O.C.
<http://www.pvi.com.tw>

Date:Oct.05,2004

This technical specification is subject to change without notice.

Please return 1 copy with your signature on this page for approval.

The information contained herein is the exclusive property of Prime View International Co., Ltd. and shall not be distributed, reproduced, or disclosed in whole or in part without prior written permission of Prime View International Co., Ltd.

TECHNICAL SPECIFICATION

CONTENTS

NO.	ITEM	PAGE
-	Cover	1
-	Contents	2
1	Application	3
2	Features	3
3	Mechanical Specifications	3
4	Mechanical Drawing of TFT-LCD module	4
5	Input / Output Terminals	6
6	Absolute Maximum Ratings	8
7	Electrical Characteristics	8
8	Power On Sequence	15
9	Optical Characteristics	16
10	Handling Cautions	19
11	Reliability Test	20
12	Indication of Lot Number Label	20
13	Block Diagram	21
14	Packing Diagram	22
-	Revision History	25

1. Application

This data sheet applies to a color TFT LCD module, PD104VT2.

PD104VT2 module applies to OA product, car TV(must use Analog to Digital drive board), which require high quality flat panel display.If you must use in high reliability environment can't over reliability test condition.

Prime View assume no responsibility for any damage resulting from the use of the device which dose not comply with the instructions and the precautions in these specification sheet.

2. Features

- . Support the DENB mode
- . Image Reversion : Up/Down and Left/Right
- . Amorphous silicon TFT LCD panel with back-light unit
- . Pixel in stripe configuration
- . Slim and compact, designed for O/A application
- . Display Colors : 262,144 colors
- . Optimum Viewing Direction : 6 o'clock
- . +3.3V DC supply voltage for TFT LCD panel driving
- . Backlight driving DC/AC inverter not included in this module
- . TTL transmission interface

3.Mechanical Specifications

Parameter	Specifications	Unit
Screen Size	26.4(diagonal)	cm
	10.4 (diagonal)	inch
Display Format	640×(R, G, B)×480	dot
Display Colors	262,144	
Active Area	211.2(H)×158.4(V)	mm
Pixel Pitch	0.330(H)×0.330(V)	mm
Pixel Configuration	Stripe	
Outline Dimension	243.0(w)×185.1 (H)×12.5 (typ.) (D)	mm
Weight	516±10	g
Back-light	CCFL, 2 tubes	
Surface treatment	Anti-glare and hard-coating	
Display mode	Normally white	

4.Mechanical Drawing of TFT-LCD Module

Outline Drawing : Front View (unit mm)

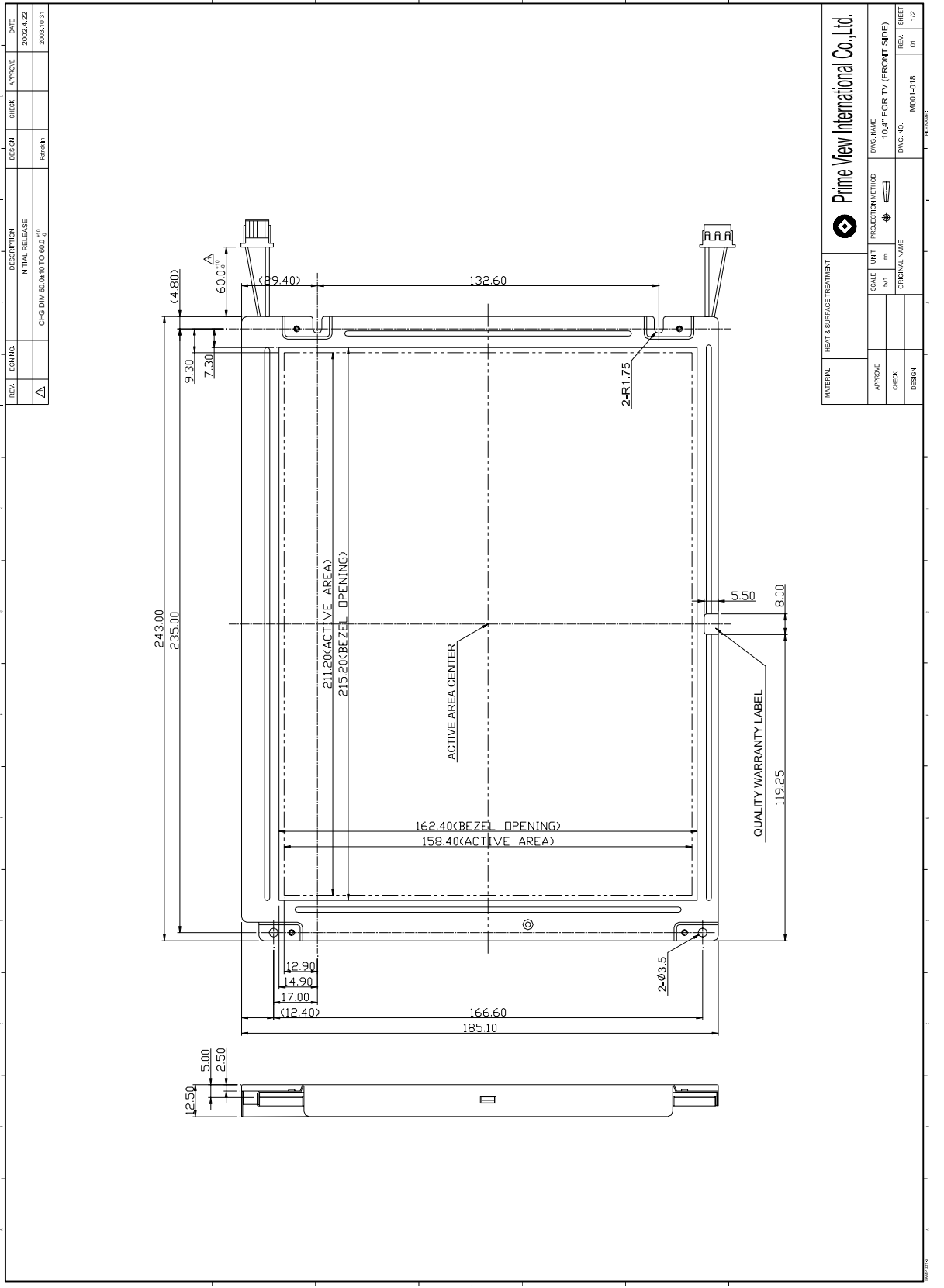

The information contained herein is the exclusive property of Prime View International Co., Ltd. and shall not be distributed, reproduced, or disclosed in whole or in part without prior written permission of Prime View International Co., Ltd. Page:4

Outline Drawing : Rear View (unit mm)

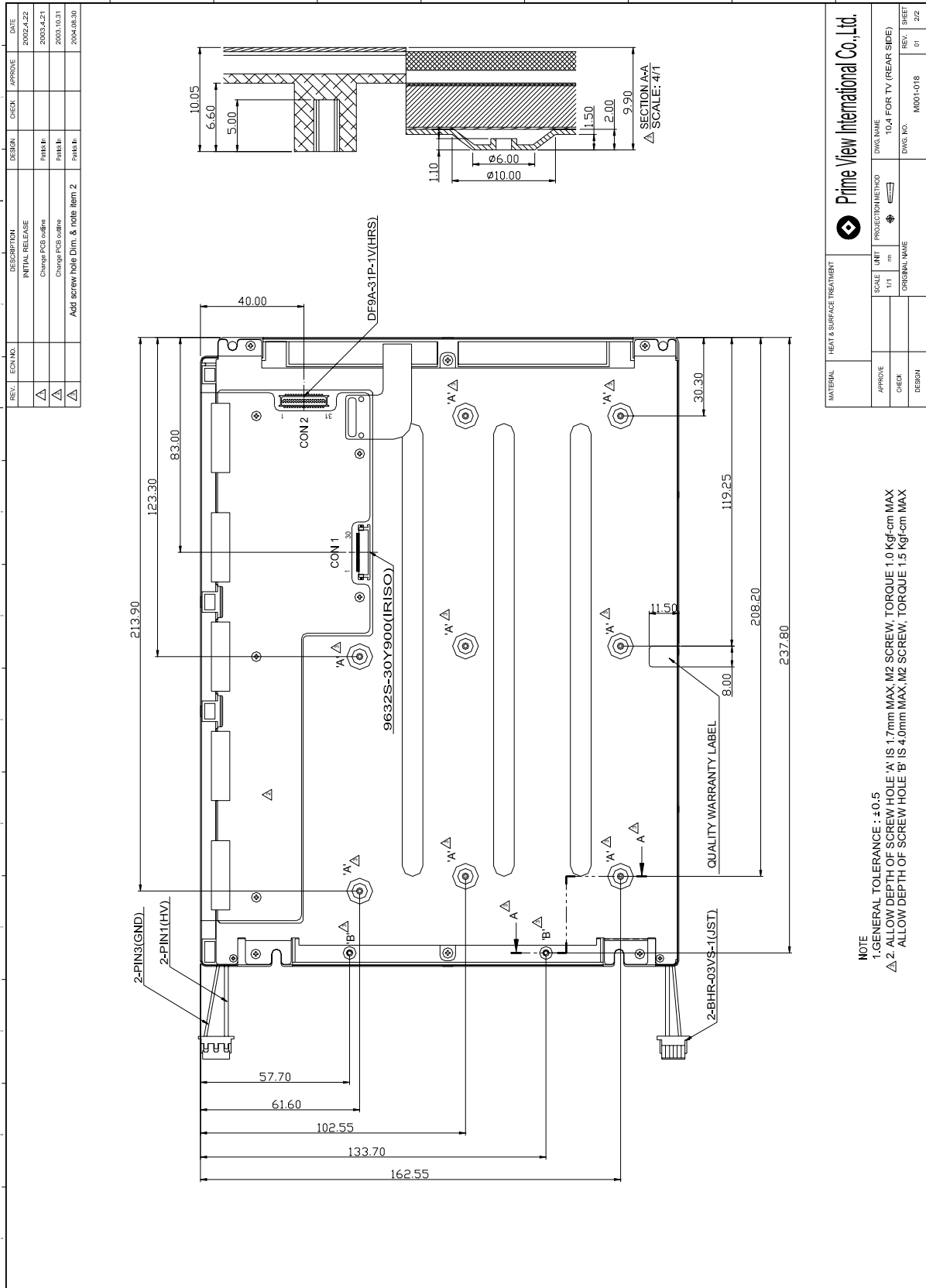

REV.	ECN NO.	DESCRIPTION	DESIGN	CHECK	APPROVE	DATE
		INITIAL RELEASE				2002.4.22
△		Change PCB outline	Part 1b			2003.4.21
△		Change PCB outline	Part 1b			2003.10.31
△		Add screw hole Dim. & note item 2	Part 1b			2004.08.30

MATERIAL		HEAT & SURFACE TREATMENT		PRIME VIEW INTERNATIONAL CO., LTD.	
APPROVE	SCALE	UNIT	PROJECTION METHOD	DWG NAME	REV. / SHEET
CHECK	1:1	mm	1st	10.4 FOR TV (REAR SIDE)	01 / 22
DESIGN				DWG. NO.	
				M001-018	

NOTE
 1. GENERAL TOLERANCE : ±0.5
 2. ALLOW DEPTH OF SCREW HOLE 'A' IS 1.7mm MAX, M2 SCREW, TORQUE 1.0 Kg·cm MAX
 △ ALLOW DEPTH OF SCREW HOLE 'B' IS 4.0mm MAX, M2 SCREW, TORQUE 1.5 Kg·cm MAX

5.Input / Output Terminals

5-1) TFT-LCD Panel Driving

Connector type : Con 2 mode DF9A-31P-1V(HRS)

Pin No.	Symbol	Function	Remark
1	GND	Ground (0V)	
2	CLK	Clock Signal for Sampling Image Digital Data	
3	Hsync	Horizontal Synchronous Signal	
4	Vsync	Vertical Synchronous Signal	
5	GND	Ground (0V)	
6	R0	Red Image Data Signal (LSB)	
7	R1	Red Image Data Signal	
8	R2	Red Image Data Signal	
9	R3	Red Image Data Signal	
10	R4	Red Image Data Signal	
11	R5	Red Image Data Signal (MSB)	
12	GND	Ground (0V)	
13	G0	Green Image Data Signal (LSB)	
14	G1	Green Image Data Signal	
15	G2	Green Image Data Signal	
16	G3	Green Image Data Signal	
17	G4	Green Image Data Signal	
18	G5	Green Image Data Signal (MSB)	
19	GND	Ground (0V)	
20	B0	Blue Image Data Signal (LSB)	
21	B1	Blue Image Data Signal	
22	B2	Blue Image Data Signal	
23	B3	Blue Image Data Signal	
24	B4	Blue Image Data Signal	
25	B5	Blue Image Data Signal (MSB)	
26	GND	Ground (0V)	
27	DENB	Data Enable Signal	Note 5-1 Note 5-2
28	VCC	DC +3.3V Power Supply	
29	VCC	DC +3.3V Power Supply	
30	R/L U/D	Horizontal Image Shift-direction Select Signal Vertical Image Shift-direction Select Signal	Note 5-4
31	GND	Ground (0V)	Note 5-5

Note 5-5: This pin must connect to ground, if without grounding the panel can't turn on.

Note 5-1 : The relationship between DENB & SYNC. mode

1. DENB mode with the top priority.
2. When working with the SYNC. mode, The Hsync and Vsync determine the timings.
3. This pin must connect to ground, if without DENB.

Mode	DENB	VGA
SYNC.		
Hsync Polarization	Don't care	Negative
Vsync Polarization	Don't care	Negative

Note 5-2 : DENB input signal.

If customer wanted to off the DENB mode , you must keep the DENB (pin 27) always High or Low.

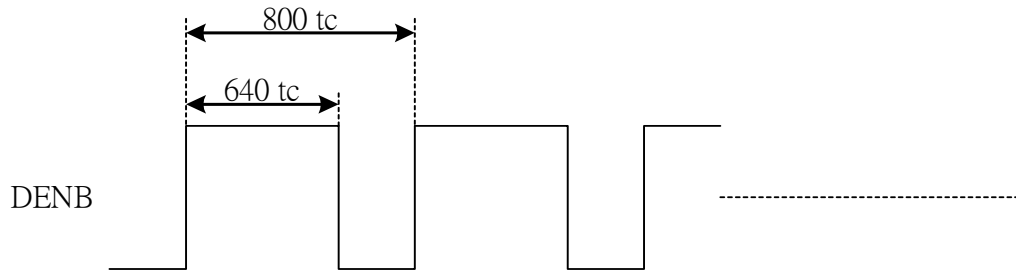

Note 5-4 : The definitions of U/D & R/L

U/D & R/L (PIN 30)= High

U/D & R/L (PIN 30)= Low

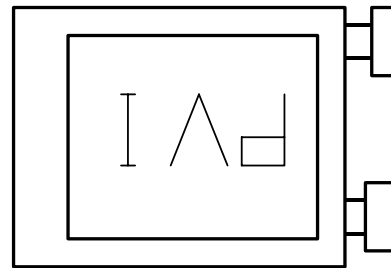
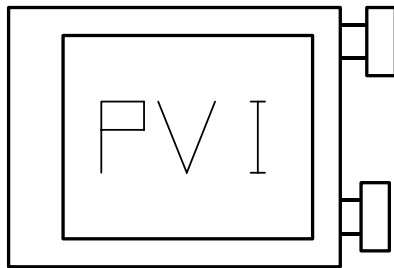

5-2) Backlight driving

Connector type:BHR-03VS-1 (JST) , PIN No 3pin, pitch=4mm

Pin No	Symbol	Description	Remark
1	VL1	Input terminal (Hi voltage side)	Wire color : Pink
2	NC	No Connection	
3	VL2	Input terminal (Low voltage side)	Wire Color : White Note 5-3

Note 5-3 : Low voltage side of backlight inverter connects with ground of inverter circuits.

6. Absolute Maximum Ratings :

The followings are maximum values , which if exceeded, may cause faulty operation or damage to the unit.

GND=0V, Ta=25°C

Parameters	Symbol	MIN.	MAX.	Unit	Remark
Supply Voltage	V _{CC}	-0.3	+4.0	V	
Input Signal Voltage	V _{IN}	-0.3	V _{CC} +0.3	V	Note 6-1
Backlight Driving Voltage	V _L	-	2000	V	
Backlight Driving Frequency	F _L	0	100	KHz	
Storage Temperature	T _{ST}	-10	+70	°C	
Operating Temperature	T _{OP}	-10	+60	°C	Note 6-2

Note 6-1 : Input signals include CLK , Hsync , Vsync , DENB , R[0:5] , G[0:5] and B[0:5].

Note 6-2 : Optical characteristics shown in Table 9-1 are measured under Ta=+25°C.

7. Electrical Characteristics
7-1) Recommended Operating Conditions:

GND = 0V , Ta = 25°C

Item	Symbol	Min.	Typ.	Max.	Unit	Remark	
Supply Voltage	V _{CC}	3.0	3.3	3.6	V		
Current Dissipation	I _{CC}	-	300	390	mA	Note 7-1	
Digital input voltage	H level	V _{IN}	0.7 V _{CC}	-	V _{CC}	V	
	L level	V _{IL}	-0.1	-	0.1 V _{CC}	V	
Lamp Current	I _{FL}	3.0	6.0	8.0	mA	Per CCFL Note 7-2 Note 7-4	
Lamp Voltage	V _L	540	540	650	V _{rms}	Note 7-2	
Lamp Initial Voltage	V _{SFL}	-	-	1060	V _{rms}	at Ta=25°C Note 7-3	
		-	-	1300		at Ta=0°C Note 7-3	
Lamp Driving Frequency	F _L	50	60	70	KHz		
Lamp Life Time		30000	-		Hrs	Note 7-5	

Note 7-1 : To test the current dissipation of Vcc, using the “color bars” testing pattern shown as below

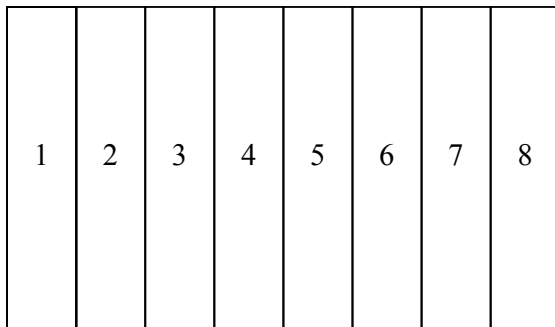

1. White
2. Yellow
3. Cyan
4. Green
5. Magenta
6. Red
7. Blue
8. Black

Idd current dissipation testing pattern

Note 7-2 : The back-light driving waveform should be as closed to sine-wave as possible. In order to satisfy the quality of B/L , no matter use what kind of inverter , the output lamp current must between Min. and Max. to avoid the abnormal display image caused by B/L.

Note 7-3 : Not including the efficiency of backlight DC/AC inverter
The kick-off time must larger than 1 second

Note 7-4 : Lamp current is measured with current meter for high frequency as shown below

Lamp current dissipation testing configuration

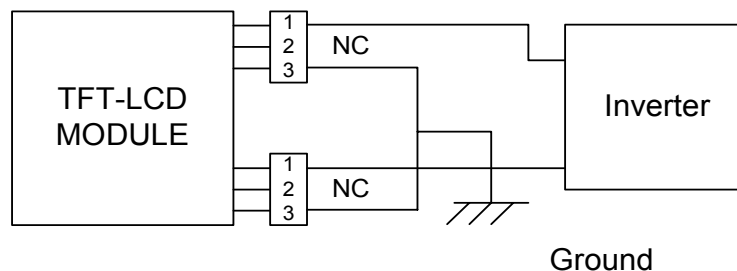

- Note1: Pin 1 is high voltage, Pin 2 NC, Pin 3 ground.
Note2: One Lamp Current is 6mA. Two Lamp 12mA.

Note 7-5: The life time is determined as the time at which brightness of lamp is 50% compare to that of initial value at the typical lamp current.

7-2) Input / Output signal timing chart

Parameters		Symbol	Min.	Typ.	Max.	Unit	Note	
CLK	Frequency	$F_c=1/T_c$		25.175		MHz	Note 7-6	
		t_c		40		ns		
Hsync	Period	Hp		31.778		us		
				800		tc		
	Display period	Hdp		640		tc		
	Pulse width	Hpw	12	96	139	tc		
	Back-porch	Hbp	12	48	139	tc		
	Front-porch	Hfp		16		tc		
	Hpw+Hbp			136	144	151	tc	
	Hsync-CLK		Hhc	10		Tc-10	ns	
Vsync-Hsync		Hvh	0	0	200	tc		
Vsync	Period	Vp		16.8		ms		
				515	525	800	Hp	
	Display period	Vdp		480		Hp		
	Pulse width	Vpw	2	2	35	Hp		
	Back-porch	Vbp	2	33	35	Hp		
	Front-porch	Vfp	1	10		Hp		
Vpw+Vbp			31	35	38	Hp		
Data	CLK-DATA	Dcd	10			ns		
	DATA-CLK	Ddc	10			ns		
DENB	Horizontal scanning period	T1	780	800	900	tc		
	Horizontal display period	T2		640		tc		
	Vertical display period	T3		480		T1		
	Frame cycling period	T4	515	525	800	T1		

Note 7-6 : Tc is the period of sampling clock. In case of low-frequency , the image-flicker may occur.

7-3) Display Time Range

(1) Vertical Timing :

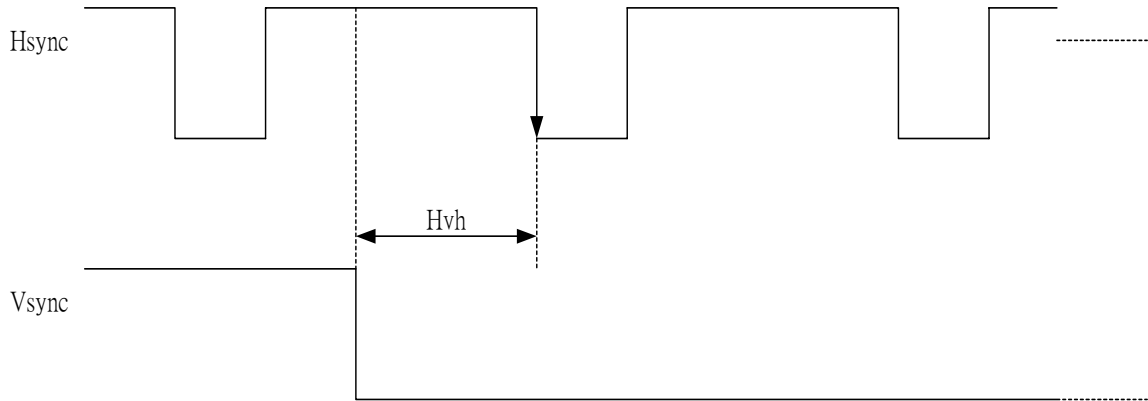

(2) Horizontal Timing :

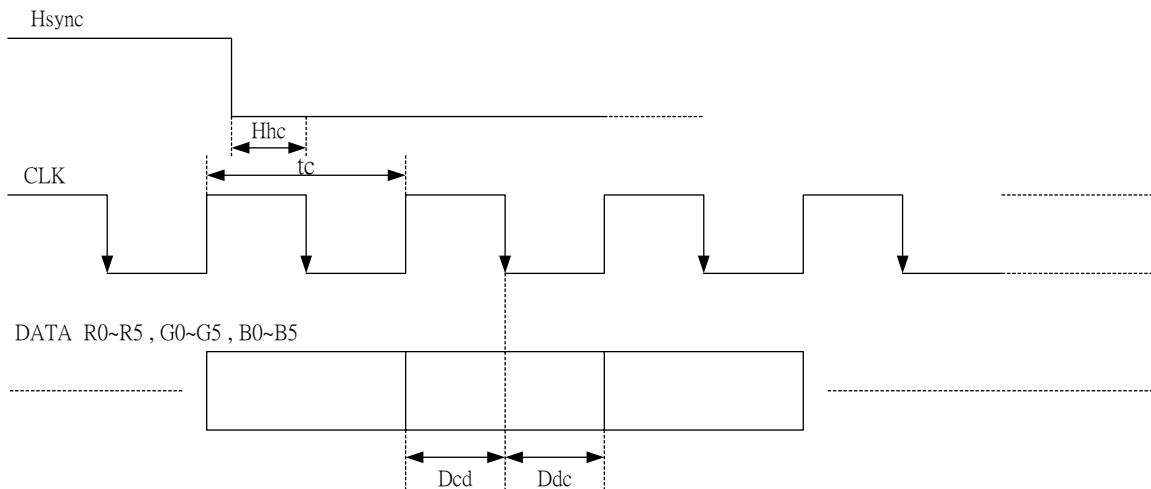

(3) DENB Timing :

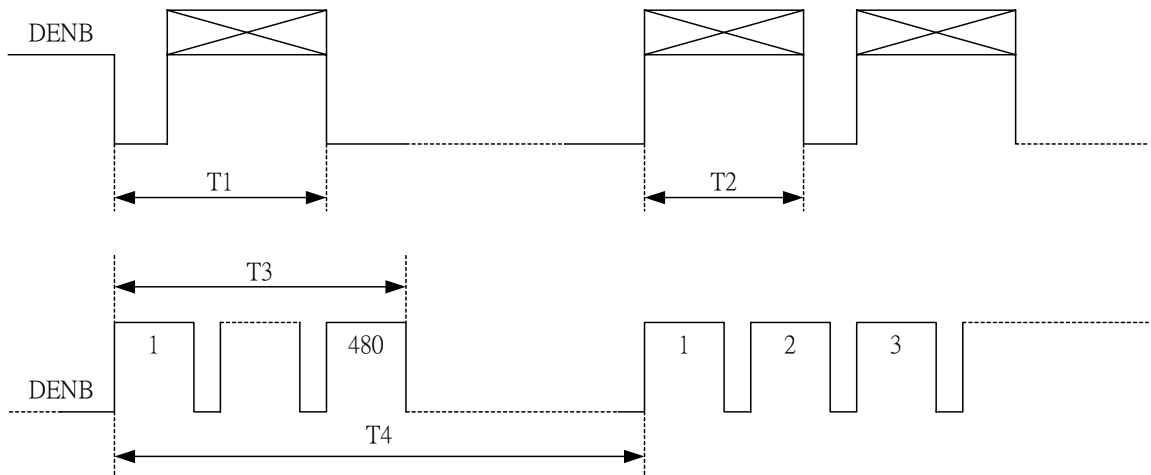

(4) Detail of Horizontal Timing :

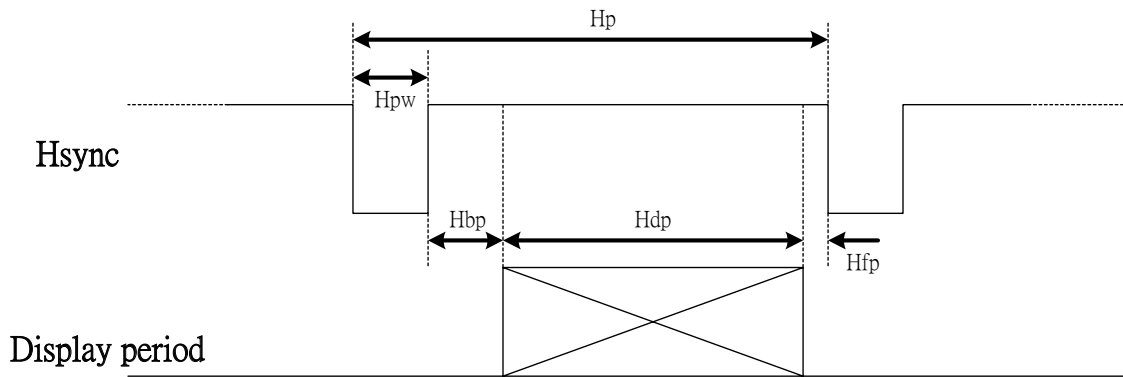

(a) VGA-480 Mode (Hsync = Negative Polarization)

Item	Description	Clock Cycles	Time
Hpw	Horizontal Width	96	3.813 μs
Hbp	Horizontal B-Porch	48	1.907 μs
Hdp	Horizontal Display	640	25.422 μs
Hfp	Horizontal F-Porch	16	0.636 μs
Hp	Horizontal Total	800	31.778 μs

(5) Detail of Vertical Timing :

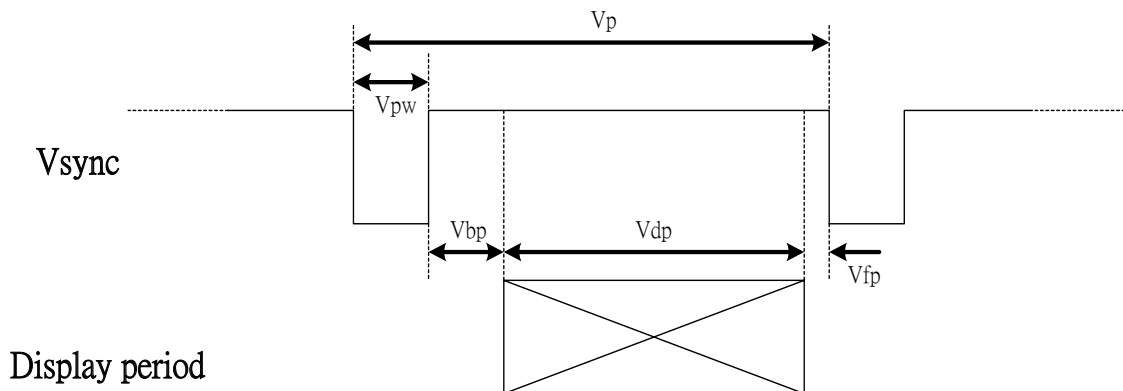

(a) VGA-480 Mode (Vsync = Negative Polarization)

Item	Description	Horizontal Lines	Time
Vpw	Vertical Width	2	63.5 μs
Vbp	Vertical B-Porch	33	1.049 ms
Vdp	Vertical Display	480	15.253 ms
Vfp	Vertical F-Porch	10	317.8 μs
Vp	Vertical Total	525	16.683 ms

7-5) Display Color and Gray Scale Reference

Color		Input Color Data																	
		Red					Green					Blue							
		R5	R4	R3	R2	R1	R0	G5	G4	G3	G2	G1	G0	B5	B4	B3	B2	B1	B0
Basic Colors	Black	0	0	0	0	0	0	0	0	0	0	0	0	0	0	0	0	0	0
	Red (63)	1	1	1	1	1	1	0	0	0	0	0	0	0	0	0	0	0	0
	Green (63)	0	0	0	0	0	0	1	1	1	1	1	1	0	0	0	0	0	0
	Blue (63)	0	0	0	0	0	0	0	0	0	0	0	0	1	1	1	1	1	1
	Cyan	0	0	0	0	0	0	1	1	1	1	1	1	1	1	1	1	1	1
	Magenta	1	1	1	1	1	1	0	0	0	0	0	0	1	1	1	1	1	1
	Yellow	1	1	1	1	1	1	1	1	1	1	1	1	0	0	0	0	0	0
	White	1	1	1	1	1	1	1	1	1	1	1	1	1	1	1	1	1	1
Red	Red (00)	0	0	0	0	0	0	0	0	0	0	0	0	0	0	0	0	0	0
	Red (01)	0	0	0	0	0	1	0	0	0	0	0	0	0	0	0	0	0	0
	Red (02)	0	0	0	0	1	0	0	0	0	0	0	0	0	0	0	0	0	0
	Darker																		
	↓	↓	↓	↓	↓	↓	↓	↓	↓	↓	↓	↓	↓	↓	↓	↓	↓	↓	↓
	Brighter																		
	Red (61)	1	1	1	1	0	1	0	0	0	0	0	0	0	0	0	0	0	0
	Red (62)	1	1	1	1	1	0	0	0	0	0	0	0	0	0	0	0	0	0
Red (63)	1	1	1	1	1	1	0	0	0	0	0	0	0	0	0	0	0	0	
Green	Green (00)	0	0	0	0	0	0	0	0	0	0	0	0	0	0	0	0	0	0
	Green (01)	0	0	0	0	0	0	0	0	0	0	0	1	0	0	0	0	0	0
	Green (02)	0	0	0	0	0	0	0	0	0	0	1	0	0	0	0	0	0	0
	Darker																		
	↓	↓	↓	↓	↓	↓	↓	↓	↓	↓	↓	↓	↓	↓	↓	↓	↓	↓	↓
	Brighter																		
	Green (61)	0	0	0	0	0	0	1	1	1	1	0	1	0	0	0	0	0	0
	Green (62)	0	0	0	0	0	0	1	1	1	1	1	0	0	0	0	0	0	0
Green (63)	0	0	0	0	0	0	1	1	1	1	1	1	0	0	0	0	0	0	
Blue	Blue (00)	0	0	0	0	0	0	0	0	0	0	0	0	0	0	0	0	0	0
	Blue (01)	0	0	0	0	0	0	0	0	0	0	0	0	0	0	0	0	0	1
	Blue (02)	0	0	0	0	0	0	0	0	0	0	0	0	0	0	0	0	1	0
	Darker																		
	↓	↓	↓	↓	↓	↓	↓	↓	↓	↓	↓	↓	↓	↓	↓	↓	↓	↓	↓
	Brighter																		
	Blue (61)	0	0	0	0	0	0	0	0	0	0	0	0	1	1	1	1	0	1
	Blue (62)	0	0	0	0	0	0	0	0	0	0	0	0	1	1	1	1	1	0
Blue (63)	0	0	0	0	0	0	0	0	0	0	0	0	1	1	1	1	1	1	

8. Power On Sequence

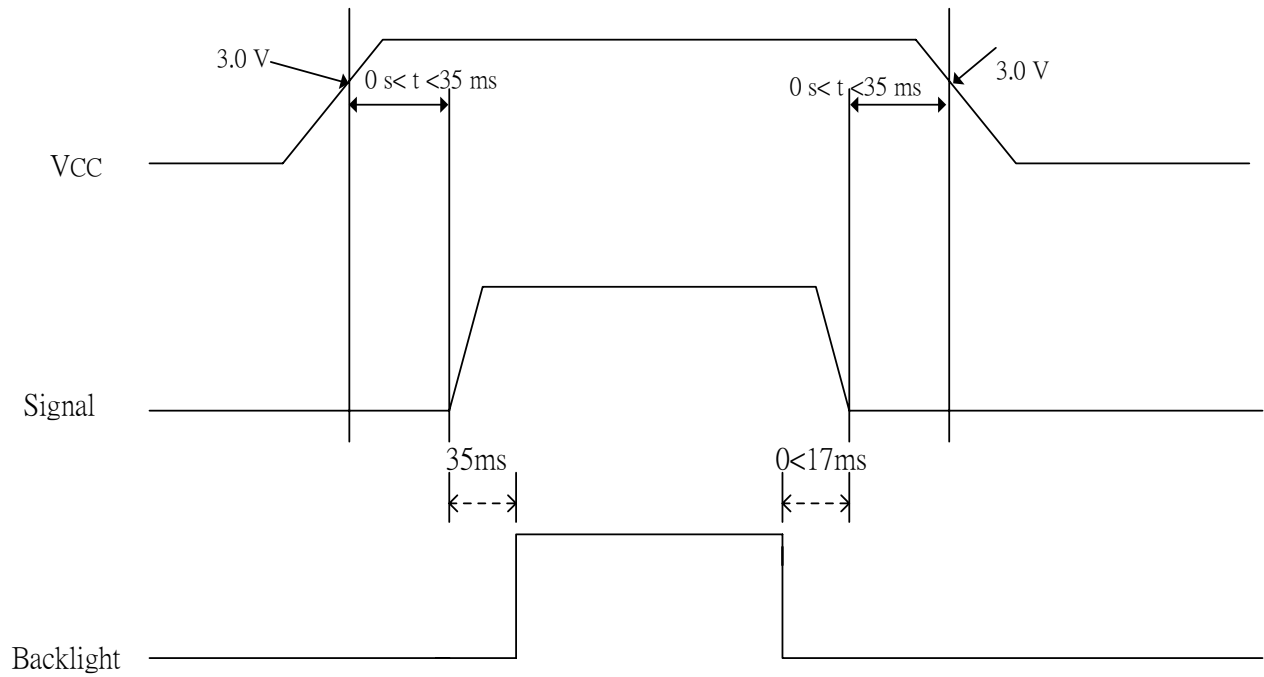

1. The supply voltage for input signals should be same as V_{CC} .
2. When the power is off , please keep whole signals (Hsync, Vsync, CLK, Data) low level or high impedance

9. Optical Characteristics

9-1) Specification:

 $T_a = 25^\circ\text{C}$

Parameter	Symbol	Condition	MIN.	TYP.	MAX.	Unit	Remarks
Viewing Angle	Horizontal	θ	± 40	± 45		deg	Note 9-3
	Vertical	θ (to 12 o'clock)	10	15	-	deg	
		θ (to 6 o'clock)	25	40	-	deg	
Contrast Ratio	CR		200	400	-	-	Note 9-1
Response time	Rise	Tr	-	15		ms	Note 9-4
	Fall	Tf	-	25		ms	
Brightness		$\theta = 0^\circ / \varphi = 0$	290	330		cd/m ²	Note 9-2
Luminance Uniformity	U		70	80	-	%	Note 9-6
Lamp Life Time			30000	-	-	hr	
White Chromaticity	x		0.279	0.309	0.339	-	
	y		0.307	0.337	0.367	-	
Cross Talk		$\theta = 0^\circ$	-	-	3.5	%	Note 9-5

All the optical measurement shall be executed 30 minutes after backlight being turn-on. The optical characteristics shall be measured in dark room (ambient illumination on panel surface less than 1 Lux). The measuring configuration shows as following figure.

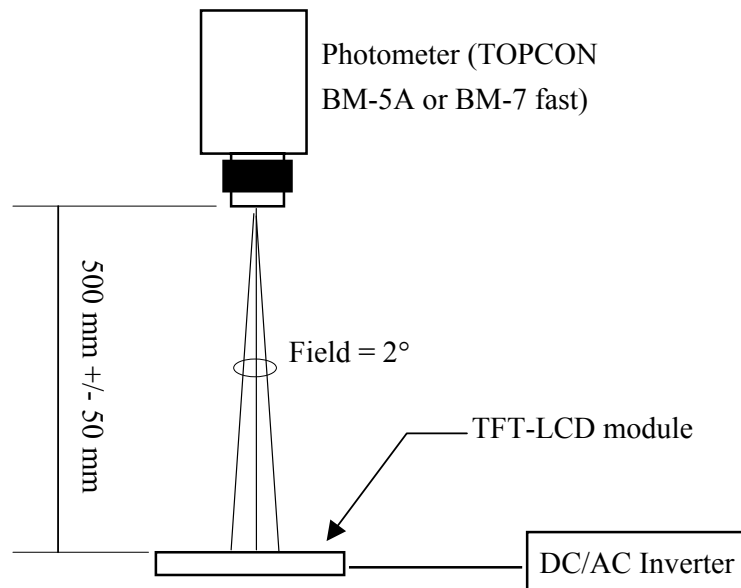

Optical characteristics measuring configuration

Note 9-1 : The definitions of viewing angles are as follow

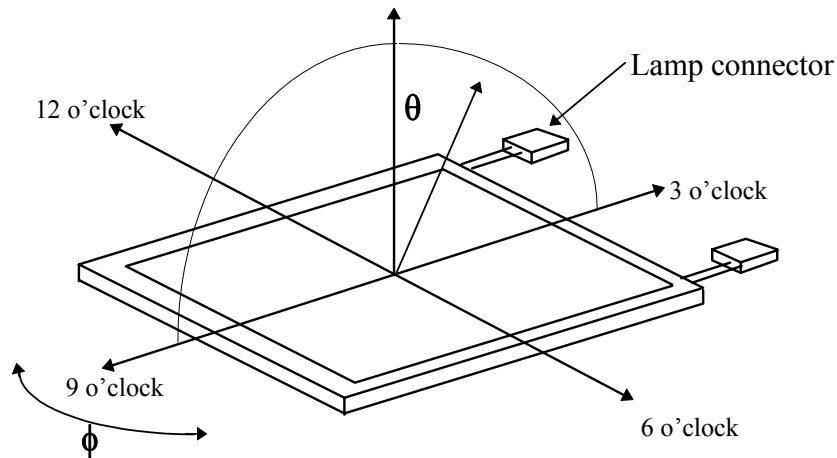

Note 9-2 : The definition of contrast ratio $CR = \frac{\text{Luminance at gray level 63}}{\text{Luminance at gray level 0}}$

Note 9-3 : Topcon BM-5A luminance meter 2° field of view is used in the testing (after 30 minutes' operation). The typical luminance value is measured at lamp current 12.0 mA.

Note 9-4: Definition of Response Time T_r and T_f :

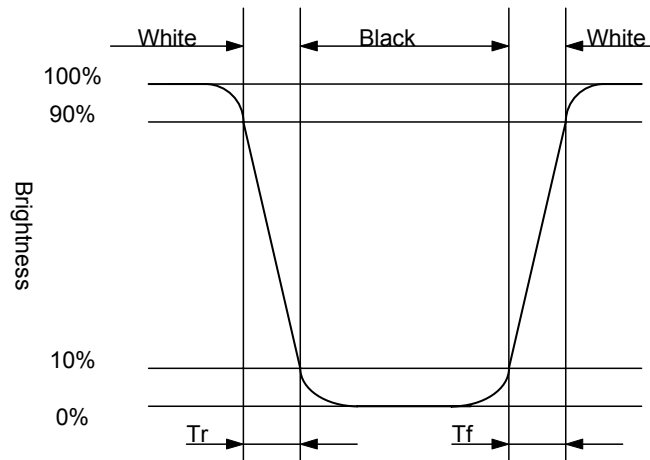

Note 9-5 : The uniformity of LCD is defined as

$$U = \frac{\text{The Minimum Brightness of the 9 testing Points}}{\text{The Maximum Brightness of the 9 testing Points}}$$

Luminance meter : BM-5A or BM-7 fast (TOPCON)
 Measurement distance : 500 mm +/- 50 mm
 Ambient illumination : < 1 Lux
 Measuring direction : Perpendicular to the surface of module
 The test pattern is white (Gray Level 63).

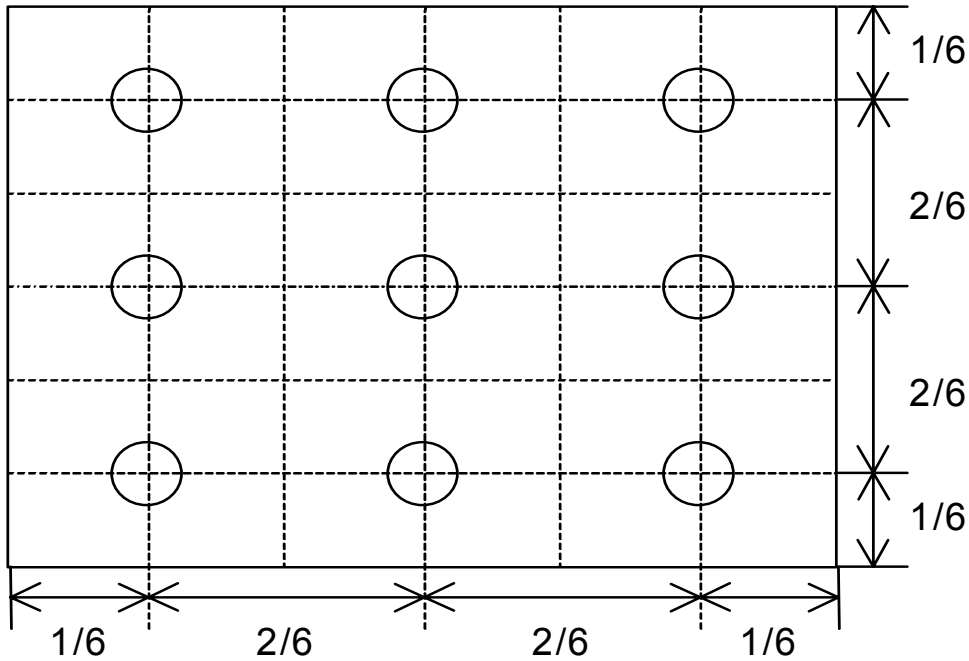

Note 9-6 : Cross Talk (CTK) = $\frac{|Y_A - Y_B|}{Y_A} \times 100\%$

Y_A : Brightness of Pattern A
 Y_B : Brightness of Pattern B
 Pattern A

(Gray Level 31)

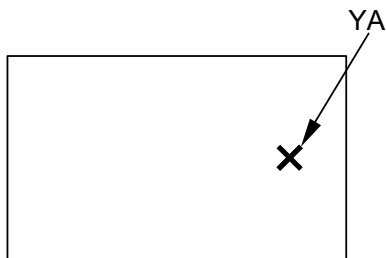

Pattern B
 (Gray Level 31, central
 black box exclusive)

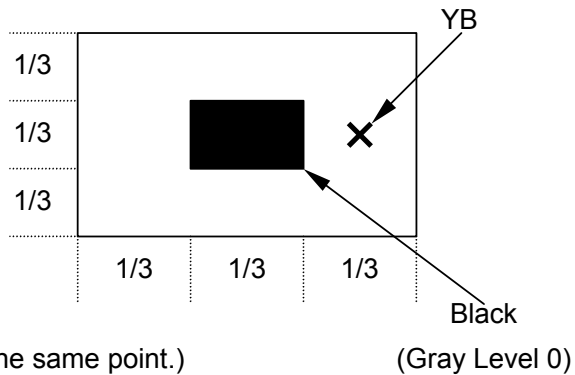

X: Testing Point (A and B are at the same point.)

10. Handling Cautions

10-1) Mounting of module

- a) Please power off the module when you connect the input/output connector.
- b) Please connect the ground pattern of the inverter circuit surely. If the connection is not perfect, some following problems may happen possibly.
 1. The noise from the backlight unit will increase.
 2. The output from inverter circuit will be unstable.
 3. In some cases a part of module will heat.
- c) Polarizer which is made of soft material and susceptible to flaw must be handled carefully.
- d) Protective film (Laminator) is applied on surface to protect it against scratches and dirt. It is recommended to peel off the laminator before use and taking care of static electricity.

10-2) Precautions in mounting

- a) When metal part of the TFT-LCD module (shielding lid and rear case) is soiled, wipe it with soft dry cloth.
- b) Wipe off water drops or finger grease immediately. Long contact with water may cause discoloration or spots.
- c) TFT-LCD module uses glass which breaks or cracks easily if dropped or bumped on hard surface. Please handle with care.
- d) Since CMOS LSI is used in the module. So take care of static electricity and earth yourself when handling.

10-3) Adjusting module

- a) Adjusting volumes on the rear face of the module have been set optimally before shipment.
- b) Therefore, do not change any adjusted values. If adjusted values are changed, the specifications described may not be satisfied.

10-4) Others

- a) Do not expose the module to direct sunlight or intensive ultraviolet rays for many hours.
- b) Store the module at a room temperature place.
- c) The voltage of beginning electric discharge may over the normal voltage because of leakage current from approach conductor by to draw lump read lead line around.
- d) If LCD panel breaks, it is possibly that the liquid crystal escapes from the panel. Avoid putting it into eyes or mouth. When liquid crystal sticks on hands, clothes or feet. Wash it out immediately with soap.
- e) Observe all other precautionary requirements in handling general electronic components.
- f) Please adjust the voltage of common electrode as material of attachment by 1 module.

10-5) Polarizer mark

The polarizer mark is to describe the direction of wide view angle film how to match up with the rubbing direction.

11. Reliability Test

No	Test Item	Test Condition	Remark
1	High Temperature Storage Test	Ta = +70°C, 240 hrs	
2	Low Temperature Operation Test	Ta = -10°C, 240 hrs	
3	High Temperature & High Humidity Operation Test	Ta = +60°C, 90%RH, 240 hrs (No Condensation)	
4	Thermal Cycling Test (non-operating)	0°C → +60°C, 50 Cycles 1Hr 1Hr	
5	Vibration Test (non-operating)	Frequency : 10 ~ 57 Hz, Amplitude : 0.5 mm 58~500Hz, 1G Sweep time: 11 min Test Period: 3 hrs (1 hr for each direction of X, Y, Z)	
6	Shock Test (non-operating)	80G, 6ms, X,Y, Z 1 times for each direction	
7	Electrostatic Discharge Test (non-operating)	150pF, 330Ω Air: ±15KV; Contact: ±8KV 10 times/point, 9 points/panel face	

Ta: ambient temperature

[Judgement Criteria]

Under the display quality test conditions with normal operation state , there should be no change which may affect practical display function.

12. Indication of Lot Number Label

1. Indicated contents of the label

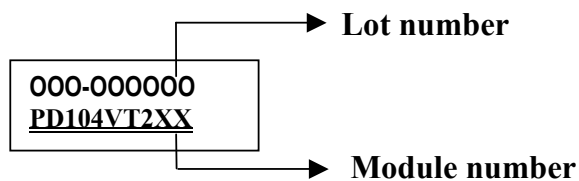

Contents of lot number : 1st—Process area : class 1000, 10K, 100K ⇒ D

2nd~3rd—Module screen size(in inch) : 1.8"⇒18, 10.4"⇒A4.....

5th—Production year : 1999⇒9, 2000⇒A, 2001⇒1.....

6th—Production month : 1, 2, 3,...9, A, B, C

7th~10th—Serial numbers : 0001~9999

13. Block Diagram

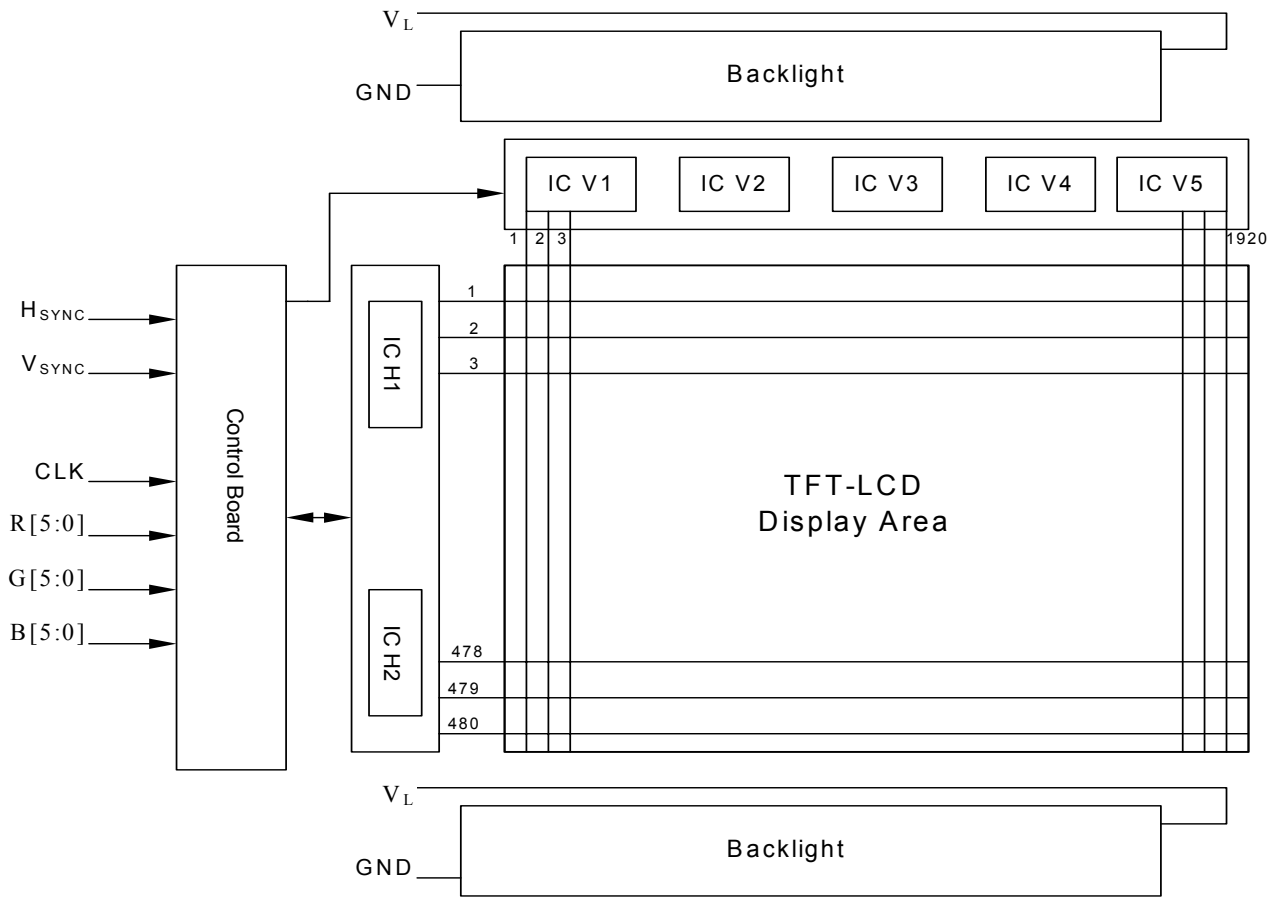

14. Packing Diagram

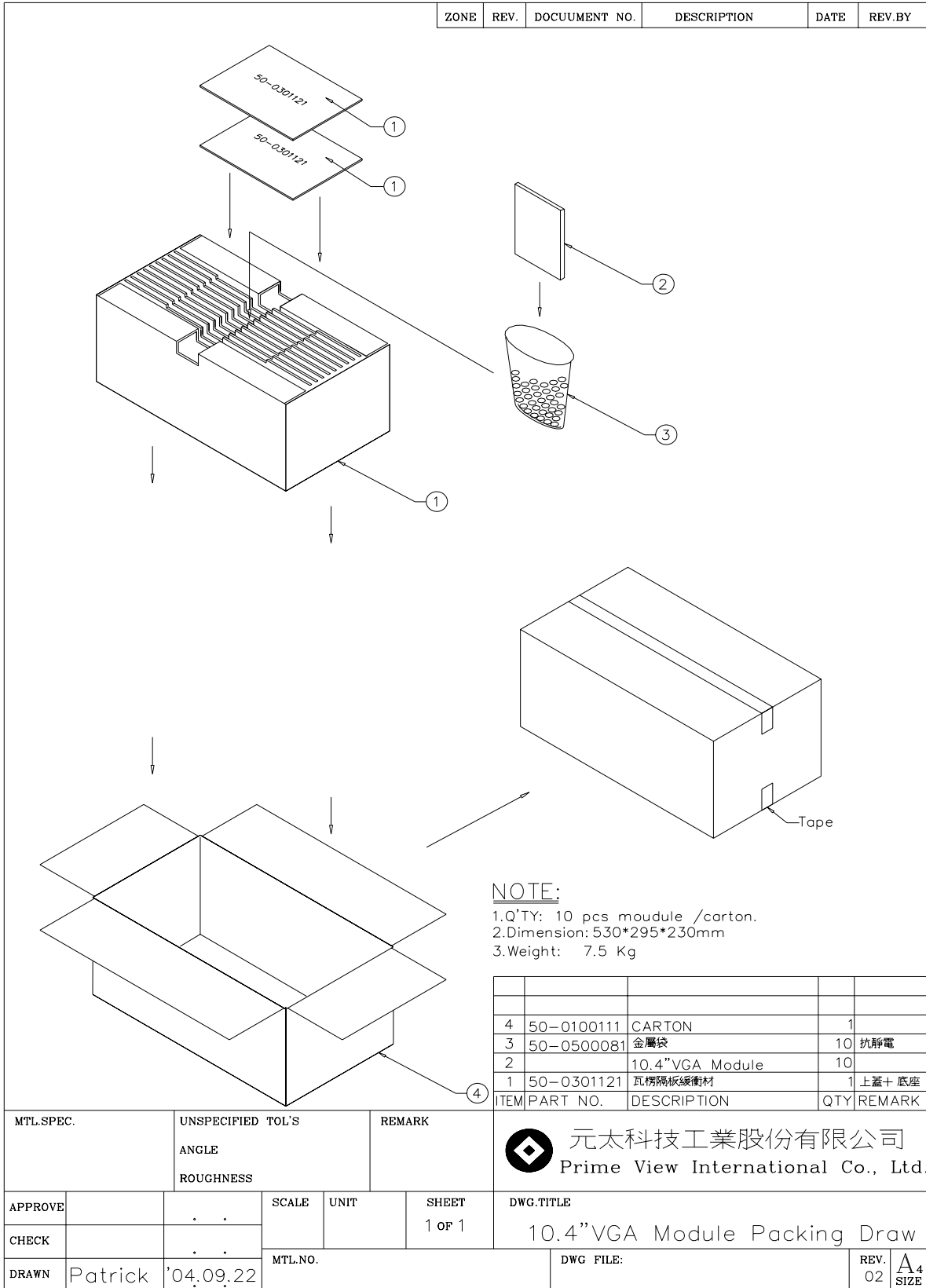

The information contained herein is the exclusive property of Prime View International Co., Ltd. and shall not be distributed, reproduced, or disclosed in whole or in part without prior written permission of Prime View International Co., Ltd. Page:21

Revision History

Rev.	Issued Date	Revised Contents
1.0	Sep 12,2002	New
1.1	Mar. 18,2003	Modify Page 5 Mechanical Drawing(change PCBA outline dimension) Modify Page 6 TFT-LCD Panel Driving (pin 31 must connect to ground) Modify Page 7-3 Input / Output signal timing chart (Back Porch form 49 to 48) Modify Page 17 Reliability test (High Temperature & High Humidity Operation Test from 60°C ,95%RH to 60°C ,90%RH)
1.2	Mar. 31,2003	Add Page 17 10.Handling Cautions Add Page 18 12. Indication of Lot Number Label
1.3	Aug. 26 ,2003	Modify Page 9 7-4 Display Time Range(remove positive input signal) Modify Page 18 11. Reliability Test(remove low temperature storage test , low temperature operation test from 0°C to -10°C) Modify Page 18 12. Indication of Lot Number Label
1.4	Nov. 25 ,2003	Modify Page 4, 5 Mechanical Drawing Add Page 6 Support the DENB mode & Image Reversion : Up/Down and Left/Right Modify Page16 Contrast Ratio (CR from Typ.180,Min.100 to Typ.400,Min.200) Modify Page 20 Indication of Lot Number Label Page 8 Electrical Characteristics a.Input/Output signal timing chart b.Display Time Range
1.5	Mar. 18 ,2004	Modify Page 7 Note 5-4:The definitions of U/D & R/L
1.6	Sep. 14, 2004	Modify Page 5 Mechanical Drawing
1.7	Sep. 30, 2004	Modify Page 21 Packing Diagram Page 9 Note 7-3 Add Lamp kick –off time